

SPECIFICATIONS

FOR

**INTERSECTION IMPROVEMENTS AT
CHESTNUT STREET AND FIFTH AVENUE**

BOROUGH OF ROSELLE

COUNTY OF UNION, NEW JERSEY

BA#23-2017; UNION COUNTY ENGINEERING PROJECT #2016-020

MAY 2017

**UNION COUNTY OFFICIALS
BOARD OF CHOSEN FREEHOLDERS**

Bruce H. Bergen, Chairman
Sergio Granados, Vice Chairman
Linda Carter, Freeholder
Angel G. Estrada, Freeholder
Christopher Hudak, Freeholder
Mohamed S. Jalloh, Freeholder
Bette Jane Kowalski, Freeholder
Alexander Mirabella, Freeholder
Vernell Wright, Freeholder

CLERK OF THE BOARD

James E. Pellettiere, RMC

COUNTY MANAGER

Alfred J. Faella

**DEPARTMENT OF ENGINEERING, PUBLIC WORKS AND
FACILITIES MANAGEMENT**

Joseph A. Graziano, Sr., CPWM
Director, Department of Engineering, Public Works and
Facilities Management

**COUNTY ENGINEER
DIVISION OF ENGINEERING**

Thomas O. Mineo, P.E.
2325 South Avenue
Scotch Plains, New Jersey 07076
Telephone: (908) 789-3675
Fax: (908) 789-3674

PREPARED BY:

T&M ASSOCIATES

11 Tindall Road
Middletown, New Jersey 07748
T: 732-671-6400

**COUNTY OF UNION
NOTICE TO BIDDERS**

Sealed bids will be received by the director of the Division of Purchasing, or her designee, at the County of Union, New Jersey on May 11, 2017 at 10:30 a.m., prevailing time, in the 6th Floor Freeholder Conference Room, U.C. Administration Building, 10 Elizabethtown Plaza, Elizabeth, New Jersey for:

**INTERSECTION IMPROVEMENTS AT CHESNUT STREET AND FIFTH AVENUE
BOROUGH OF ROSELLE, COUNTY OF UNION, NEW JERSEY
BA#23-2017; UNION COUNTY ENGINEERING PROJECT #2016-020**

Bid Packages may be obtained at no charge by registering and downloading at <http://ucnj.org/bid-specs>. Bid Packages may also be obtained in person from the Division of Engineering at 2325 South Avenue, Scotch Plains, New Jersey 07076 between 8:30 a.m. and 4:00 p.m. weekdays upon payment of a non-refundable money order or bank check in the amount of \$275.00 made payable to the County of Union. No Personal / Company checks will be accepted. Requests for mailing of specifications will not be honored. For further information please call 908-789-3675.

The County reserves the right to reject any and all bids and to waive any and all informalities in the bid.

Bids shall be submitted in a sealed envelope and clearly marked with the subject of the bid, name and address of the bidder, phone & fax number, and date of the bid opening. Each bid must be delivered to reach the Division of Purchasing prior to the stated time of the opening of the bids. The County will not be responsible for late delivery by the U.S. Mail or any other carrier. If hand delivered, please note that parking and security access at the County Complex may cause delays and bidders should take them into consideration in order to submit a timely bid. **No** late bids will be accepted.

Bidders are required to comply with the requirements of N.J.S.A. 10:5-31 et seq. and N.J.S.A.C. 17:27.

LAURA M. SCUTARI, QPA, MPA, DIRECTOR OF PURCHASING

**UNION COUNTY BOARD
OF CHOSEN FREEHOLDERS**

We're Connected to You!

NB-1

**INTERSECTION IMPROVEMENTS AT CHESTNUT STREET AND FIFTH AVENUE
BOROUGH OF ROSELLE, COUNTY OF UNION, NEW JERSEY
BA#23-2017; Union County Engineering Project 2016-020**

TABLE OF CONTENTS

Cover Sheet: County Officials
NB-1: Notice to Bidders

GENERAL SPECIFICATIONS

Definitions

Section 1: BID FORM
Section 2: WITHDRAWAL OF BID DUE TO MISTAKE
Section 3: QUALIFICATIONS OF BIDDERS AND REQUIRED SUBMISSIONS
Section 4: INTERPRETATIONS AND ADDENDA
Section 5: OBLIGATION OF BIDDER TO INSPECT SITE AND CONTRACT DOCUMENTS
Section 6: BID AND PERFORMANCE GUARANTEE
Section 7: COMMENCEMENT AND COMPLETION
Section 8: BIDDER AFFIDAVIT
Section 9: BID SECURITY
Section 10: LABOR AND MATERIALS
Section 11: INSURANCE REQUIREMENTS
Section 12: INDEMNIFICATION REQUIREMENTS
Section 13: ROYALTIES AND PATENTS
Section 14: PLANS AND SPECIFICATIONS
Section 15: GUARANTEE AGAINST DEFECTIVE WORK
Section 16: TRAFFIC AND STREET MAINTENANCE
Section 17: CONTRACTOR'S EMPLOYEES
Section 18: OWNERSHIP DISCLOSURES REQUIRED
Section 19: NON-COLLUSION AFFIDAVIT
Section 20: EQUAL EMPLOYMENT OPPORTUNITY COMPLIANCES
Section 21: COMPLIANCE WITH NEW JERSEY PREVAILING WAGE ACT
Section 22: BRAND NAME OR EQUAL
Section 23: LINES AND GRADES
Section 24: NUMBER OF WORKING DAYS
Section 25: PROMPT PAYMENT OF CONSTRUCTION CONTRACTS (NJ Prompt Payment Act)
Section 26: STOPPING WORK ON ACCOUNT OF BAD WEATHER
Section 27: ACCESS FOR OTHER CONTRACTORS
Section 28: CONDEMNED MATERIALS AND WORK
Section 29: STORAGE
Section 30: FINAL CLEAN UP
Section 31: SUB-LETTING OF WORK
Section 32: SAFETY
Section 33: QUALITY, SAFETY AND PERFORMANCE STANDARDS
Section 34: MATTERS NOT MENTIONED IN CONTRACT DOCUMENTS
Section 35: PERMITS
Section 36: CONTRACTOR TO PROVIDE PROOF OF PAYMENT
Section 37: CHANGE ORDERS
Section 38: SUPPLEMENTAL WORK
Section 39: FORM OF CONTRACT
Section 40: PROGRESS PAYMENTS
Section 41: INSPECTION
Section 42: DAMAGES
Section 43: LIQUIDATED DAMAGES
Section 44: AFFIRMATIVE ACTION REQUIREMENTS
Section 45: INVESTMENT ACTIVITIES WITH IRAN

GENERAL SPECIFICATIONS CONTINUED

- Section 46: COMPLIANCE WITH THE PUBLIC WORKS CONTRACTOR REGISTRATION ACT
(N.J.S.A. 34:11-56.48 et seq)
- Section 47: UTILITIES
- Section 48: MATERIAL COMPLIANCE AND SHOP DRAWINGS
- Section 49: PRECONSTRUCTION
- Section 50: DISPUTES UNDER THE CONTRACT
- Section 51: CONTRACTOR BUSINESS REGISTRATION CERTIFICATE
(New Mandatory Requirement – Effective 1/18/2010)
- Section 52: BID PROTEST - LEGAL FEES AND COSTS
- Section 53: AMERICAN GOODS AND PRODUCTS WHERE POSSIBLE
- Section 54: NEW JERSEY PAY-TO-PLAY REQUIREMENTS
- Section 55: STATEMENT OF EQUIPMENT TO BE USED IN CONSTRUCTION
- Section 56: NEW JERSEY SALES AND USE TAX REQUIREMENTS

BIDDING DOCUMENTS

- Bid Document Submission Checklist
- Bidding Documents
- Bid Form
- Consent of Surety
- Bidder Signature Page
- Bidder Disclosure Statement
- Subcontractor Identification Statement: List of Subcontractors
- Subcontractor Identification Certification
- Acknowledgement of Addendum
- Contractor Business Registration Certificate
- Affirmative Action Requirement
- Experience Statement
- Certificate of Bidder Showing Ability to Perform Contract
- Non-Collusion Affidavit
- Contractor Registration Advisement
- Americans with Disabilities Act
- Statement of Bidder's Qualifications
- Contractor Performance Record
- Affidavit Regarding List of Disbarred, Suspended or Disqualified Bidders
- Prior Negative Experience Questionnaire-Certification
- Contractor's Certification of Compliance - New Jersey Prevailing Wage Act
- Uncompleted Contracts Affidavit
- Certificate of Insurance Statement
- Collection of Use Tax on Sales to Local Governments Statement
- Time of Completion
- Disclosure of Investment Activities in Iran

STANDARD SPECIFICATION FORM - SS-1

NEW JERSEY PREVAILING WAGE DETERMINATION DOCUMENTS

PROJECT TECHNICAL SPECIFICATIONS

**UNION COUNTY BOARD OF CHOSEN FREEHOLDERS
INSTRUCTIONS TO BIDDERS AND FORMS**

DEFINITIONS

Wherever reference is made to the County, Title of Project, Bidder, or Vendor/Contractor they shall be as follows:

OWNER/COUNTY:

Union County Board of Chosen Freeholders
UC Administration Building, 6th Floor
10 Elizabethtown Plaza
Elizabeth, New Jersey 07207

ADDRESS BIDS AND SUBMIT TO:

Union County Division of Purchasing
UC Administration Building, 3rd Floor
10 Elizabethtown Plaza
Elizabeth, NJ 07207
Attn: Laura M. Scutari, QPA, MPA, Director, Division of Purchasing
Telephone: 908-527-4130
Facsimile: 908-558-2548

**TITLE OF PROJECT: Intersection Improvements at Chestnut Street and Fifth Avenue
Borough of Roselle
County of Union, New Jersey
BA#23-2017; Union County Engineering Project #2016-020**

BIDDER: Bidder shall be a single overall contract bidder

ENGINEER: T&M Associates

11Tindall Road
Middletown, New Jersey 07748

COUNTY ENGINEER AND/OR CONSTRUCTION MANAGER (as applicable):

COUNTY ENGINEER:

Thomas O. Mineo, P.E.
Union County
Division of Engineering
2325 South Avenue
Scotch Plains, NJ 07076
Office: (908) 789-3675
Facsimile: (908) 789-3674
Email: tmineo@ucnj.org

CONSTRUCTION MANAGER:

GENERAL SPECIFICATIONS

1. BID FORM

Bids for this Work will be enclosed in a sealed envelope addressed to the Purchasing Division, County of Union, New Jersey, Union County Administration Building, 10 Elizabethtown Plaza, Elizabeth, New Jersey 07207, with the full name of the Project clearly marked on the outside. Refer to the sheet marked "Notice of Bid (Advertisement)" for the correct name of the Project. Bidders must submit their bids on the attached pricing sheet (Bid Form), in a sealed envelope addressed to the County and bearing on the outside: the name of the Bidder, Bidder's business address, and the title of the Project.

The Division of Purchasing will receive the bids for this Work at the Union County Administration Building, 10 Elizabethtown Plaza, Elizabeth, New Jersey on the date and time noted on the sheet marked "**Notice of Bid (Advertisement)**".

The County will not assume responsibility for bids forwarded by mail. It is the individual's responsibility to see that the bids are presented to the Purchasing Division at the time and at the place designated.

Bids will be accepted only on the Bid Form supplied. Bids on forms other than the original supplied herein will be rejected. The "complete" Bid Documents includes the Bid Bond, Bid Form, Bidder's Checklist, Consent of Surety, Ownership Disclosure Certification, Non-Collusion Affidavit, and any other documents noted in these Instructions to Bidders or Contract Document to be submitted with this Bid.

The bidder will state in the bidding sheet the price per unit of measure for each scheduled Item of Work for which he will agree to carry out the Work, and the Total Bid Price for the construction of the Project.

The prices in the Bid Form shall be typed or written in pen and ink. Erasures or alterations must be initialed by the bidder in ink.

The bidding sheet for this Project may include a fixed amount as a Bid Allowance. If applicable, all bidders are required to add this fixed amount to their base bid and to include this additional amount in their Bid Bond. This sum will be included in the Contract as well as the performance, labor and materials bond. Payment by the County will be made to the Contractor from these funds only upon the completion of extra Work pursuant to a written Change Order(s) signed by the County's Engineer or his designee and the Contractor, prior to the commencement of such Work. Work commenced prior to written approval by the County shall be done at Contractor's risk. Such payment will only be in the amount agreed to by the parties, in writing in the Change Order(s). See Section 37, Change Orders, of these general specifications for further details.

Refer to Bid Document Submission Checklist for all required documents.

In the event there is a discrepancy between the unit price given and the extended total, the unit price will govern. Any discrepancies will be mathematically adjusted.

Insert applicable alternates, if any have been specified, applicable to the Bidder's Work. All alternates MUST be bid upon. Any Bidder's failure to do so will be deemed a material, non-waivable defect and shall render the bid nonresponsive. The Bidder shall clearly designate whether the change in price is an addition or subtraction, by using either a "+" sign or the word "addition", or in the alternative, a "-" sign or the word "minus". If there is no other change in price, the Bidder shall insert "NC" or "No Charge".

When two or more low bids are equal in all respects, awards will be made according to the provisions of N.J.S.A. 40A:11-6.1(d).

Where unit prices have already been established by the Contract Documents, the Bidder agrees that such unit prices shall prevail. All unit prices, whether filled in by the Bidder or established by the Contract Documents, shall become part of the Contract. No bid will be considered or award made, unless applicable unit prices, as required, are filled in.

The County reserves the right to reject any or all bids and also reserves the right to waive any informality in the bids received so long as said waiver is not of a response which is considered to be material and non-waivable pursuant to law.

The County of Union has the right to reject any and all bids from any bidder that is in, or contemplates bankruptcy of any chapter of nature. Said bidder shall notify the County, in writing, of any condition or knowledge of the same.

Conditional bids will not be accepted. Bids may be withdrawn prior to the advertised time for the opening of bids or authorized postponement thereof or in accordance with the provisions of N.J.S.A. 40A:11-23.3 discussed below. Bids received after the advertised time shall not be considered. Bidders shall be solely responsible for premature opening or late delivery of bids not properly marked, addressed, or directed.

2. WITHDRAWAL OF BID DUE TO MISTAKE

N.J.S.A. 40A:11-23.3 authorizes a bidder to request withdrawal of a public works bid due to a mistake on the part of the bidder. A mistake is defined by N.J.S.A. 40A:11-2(42) as a clerical error that is an **unintentional and substantial computational error or an unintentional omission of a substantial quantity of labor, material, or both, from the final bid computation.**

A bidder claiming a mistake under N.J.S.A. 40A:11-23.3 must submit a request for withdrawal, **in writing**, by certified or registered mail to Michael M. Yuska, QPA, Director, Division of Purchasing, County of Union, New Jersey, Union County Administration Building, 10 Elizabethtown Plaza, Elizabeth, New Jersey 07207. The bidder must request withdrawal of a bid due to a mistake, as defined by the law, within five business days after the receipt and opening of the bids. Since the bid withdrawal request shall be effective as of the postmark of the certified or registered mailing, Michael M. Yuska, QPA, Director of the Division of Purchasing or his designee may contact all bidders, after bids are opened, to ascertain if any bidders wish to, or already have exercised a request to withdraw their bid pursuant to N.J.S.A. 40A:11-23.3.

A bidder's request to withdraw the bid **shall** contain evidence, including any pertinent documents, demonstrating that a mistake was made. Such documents and relevant written information shall be reviewed and evaluated by the County's designated staff pursuant to the statutory criteria of N.J.S.A. 40A:11-23.3.

The County will not consider any written request for a bid withdrawal for a mistake, as defined by N.J.S.A. 40A:11-2(42), by a bidder in the preparation of a bid proposal unless the postmark of the certified or registered mailing is within the five business days following the opening of bids.

3. QUALIFICATIONS OF BIDDERS AND REQUIRED SUBMISSIONS

The County may make such investigation as it deems necessary to determine the ability of the Bidders to perform the Work, which includes investigation of any and all subcontractors listed with the bid. The Bidder shall furnish any information and data for this purpose as the County may request.

4. INTERPRETATIONS AND ADDENDA

Any explanation desired by a bidder regarding the meaning or interpretation of the Contract Documents must be requested in writing to the County Engineer or Design Professional as the case may be and with reasonable time allowed for a reply to reach bidders before submission of their bids. Any interpretation or instruction made by the County Engineer will be in the form of an addendum to the Contract Documents or clarification and will be furnished to all prospective bidders. Oral explanations or instructions given before the award of the Contract will not be binding. Bidders are required to bring to the attention of the County Engineer, the discovery of any apparent ambiguity, inconsistency, error, discrepancy, omission in the Contract Documents for interpretation and correction at least ten (10) working days before opening of bids with the exception of Saturdays, Sundays and holidays.

All Addenda issued through the Offices of the County Engineer are amendments to the Contract Documents and shall be considered in preparing bids. Same shall become part of the Contract Documents.

Addenda take precedence over all earlier documents and over each other according to the latest date. Addenda unless themselves interpretive remain subject to interpretation the same as any other document incorporated in the Contract.

Addenda may be issued by the County Engineer up to seven (7) working days prior to the opening of bids. Failure of any bidder to receive an addendum shall not relieve such bidder from the obligation imposed by such addendum. Bidders are to keep themselves currently acquainted with the Contract Documents during the entire bidding period and make inquiry on their own initiative as to issuance of any Addenda. Receipts of all Addenda shall be acknowledged on the “*Acknowledgement of Receipt of Changes*” included in the bid package and must be submitted with the bid.

5. OBLIGATION OF BIDDER TO INSPECT SITE AND CONTRACT DOCUMENTS

At the time of the opening of bids, each Bidder will be presumed to have inspected the site(s) and to have read, and be thoroughly familiar with the Contract Documents. The failure or neglect of any Bidder to receive or examine any form, instrument, or document shall in no way relieve any Bidder from any obligation in respect to its bid.

The Bidder shall examine the contents of the Project Manual and the set of Drawings and assure itself that all pages of the Specifications, Drawings, and other Contract Documents are included in the documents obtained for bidding purposes. Should the Specifications, Drawings, and other Contract Documents be incomplete, the Bidder shall notify the County Engineer in writing, who will supply the Bidder with any missing pages of Specifications, Drawings, or other Contract Documents. The lack of such written notification by the Bidder will be construed as evidence that the Specifications, Drawings, or other Contract Documents supplied it for bidding purposes are full and complete and as a waiver of any subsequent claim to the contrary.

6. BID AND PERFORMANCE GUARANTEE

Each bidder must furnish a Bid Bond, Certified Check or Bank Cashier’s Check in the amount of ten percent (10%) of the Bid. Checks shall be drawn to the order of the County of Union, New Jersey, not to exceed \$20,000.

Each bidder must furnish with the bid a certificate from a Surety Company, i.e. Consent of Surety, stating that in the event of the contract being awarded to said bidder, such Surety Company will provide the Contractor with Bonds guaranteeing the faithful performance of the Work in accordance with the plans and specifications, and the payment for labor, materials, and all other indebtedness which may accrue on the account of this Work. A Performance, Labor and Materials bond will be furnished by the Contractor upon an award of Contract, and will be in the amount of 100% of the contract price.

A one-year Maintenance Bond will be required upon acceptance of the Project by the County in the amount as stated in Section 15 of the General Specifications. Bonds will be written by a firm authorized to issue the bonds under the laws of the State of New Jersey and be in a form acceptable to the County Counsel.

N.J.S.A. 40A:11-1.1 et. seq. allows the prime Contractor to furnish the Performance Security for his Subcontractors. The County of Union requires Performance Security to be furnished by the prime contractor for the entire job in the total amount of the contract.

The County of Union shall award the contract or reject all bids within sixty (60) days; except that the bids of any bidders who consent thereto may, at the request of the County be held for consideration for such longer periods as may be agreed.

The County will return all certified checks or cashier's checks after the proposals have been opened, read, tabulated and checked except those of the three (3) bidders who have bid the lowest total price for carrying out the Project. The County will return the checks of these bidders when a contract is awarded to the successful bidder within ten (10) days after the award of the contract.

If the successful bidder refuses or neglects to sign the said Agreement and furnish the required bonds, the Bid Bond will be held and used by the County to offset any damages for such refusal or neglect.

7. COMMENCEMENT AND COMPLETION

Work will not commence until a Notice to Proceed is received from the County Engineer.

Upon substantial completion of the Project, the Contractor must request a joint inspection with the County Engineer. Upon completion of this inspection, the County Engineer will prepare a list of incomplete or incorrect items (punch list) and have Contractor initial and date same. The Contractor shall rectify all deficiencies noted on the punch list within 30 calendar days of receipt of the list. The County Engineer may approve extensions for extenuating circumstances.

8. BIDDER AFFIDAVIT

All Bidders are required to complete, sign, and submit with their Bid, the attached "Affidavit Regarding List of Debarred, Suspended or Disqualified Bidders". (See form enclosed)

9. BID SECURITY

All Bidders are required to submit a form of Bid Security with their bids.
(Bid Bond or Certified Funds)

The Bid Security shall be in the amount of ten percent (10%) of the Bid, but not in excess of Twenty Thousand Dollars (\$20,000.00), and payable to the order of the "County of Union."

10. LABOR AND MATERIALS

The prices will cover all costs of any nature incident to and growing out of the Work, including all labor, material, equipment, transportation, loss by damage or destruction of the Project, settlement of damages, and for replacement of defective work or materials. N.J.S.A. 54:32B-1 et seq. exempts all materials sold to the County of Union from sales or use taxes and should not be included in the prices provided on the Bidding Sheet.

11. INSURANCE REQUIREMENTS

The County of Union requires all contractors to be able to comply with the following insurance requirements. In the event a bid is accepted by the County, the contractor must accept the applicable insurance requirements, as set forth below, as part of any contract awarded to it by the County.

Contractor shall carry and maintain at all times while the contract is in full force and effect, the following insurance coverage with an insurance company or companies acceptable to the County, with limits not less than those shown below. A Certificate of Insurance shall be filed with the County prior to commencement of any Work indicating the following:

- a) Commercial General Liability (CGL): Coverage for all operations including, but not limited to, contractual, products and completed operations, and personal injury with limits no less than \$5,000,000 per occurrence/\$10,000,000 aggregate. The County of Union, its Board of Chosen Freeholders, officers, employees, agents and servants shall be included as an additional insured. Coverage is provided on a primary and non-contributory basis to the County of Union, et al.
- b) Automobile Liability: Coverage for all owned, non-owned and hired vehicles with limits not less than \$5,000,000 per occurrence, combined single limits (CSL) or its equivalent.
- c) Workers Compensation: As required by the State of New Jersey and Employers Liability with limits not less than \$1,000,000 per accident for bodily injury or disease.
- d) Professional Liability (if design/build): Coverage with limits not less than \$1,000,000 per occurrence or claim, \$2,000,000 aggregate

- e) Contractor's Pollution Legal Liability and/or Asbestos Legal Liability and/or Errors & Omissions (if project involves environmental hazards): Coverage with limits no less than \$1,000,000 per occurrence or claim/\$2,000,000 aggregate.
- f) Builders Risk (for major renovations): During the course of construction utilizing an "All Risk" coverage form with limits equal to the completed value of the project and no coinsurance penalty provisions.

Where applicable, a waiver of subrogation in favor of the County of Union, its Board of Chosen Freeholders, officers, employees, agents, servants and the State of New Jersey is to be included in those policies of insurance where permitted by law.

Notice of Cancellation: Each insurance policy required above shall provide that coverage shall not be canceled, except with notice to the Entity.

Special Risks or Circumstances: The County reserves the right to modify these requirements, including limits, based on the nature of the risk, prior experience, insurer, coverage, or other special circumstances.

12. INDEMNIFICATION REQUIREMENTS

The County of Union requires all bidders to accept the following indemnification requirements in the event the County accepts their bid. The Contract awarded by the County to the successful bidder will contain the following provision:

"To the fullest extent permitted by law the Contractor shall indemnify and hold harmless the owner and the owner's consultants, agents, representatives, and employees from and against any and all claims, damages, losses, costs, and expenses, including, but not limited to attorneys' fees, legal costs and legal expenses arising out of or resulting from the performance of the Contractor's work under this contract, provided that such claim, damage, loss, cost, or expense is attributable to bodily injury, sickness, disease or death, or to injury to or destruction of tangible property (other than the work itself) caused or alleged to be caused by the negligent acts, negligent omissions, and/or fault of the Contractor, anyone directly or indirectly employed or retained by the Contractor, or anyone for whose acts the Contractor may be liable regardless of whether caused in part by the negligent act or omission of a party indemnified hereunder provided it is not caused by the sole negligence of a party indemnified hereunder. Contractor shall further indemnify and hold harmless the County and the County's consultants, agents, representative, and employees from and against any and all claims, damages, losses, costs, and expenses, including, but not limited to attorneys' fees, legal costs and legal expenses, arising out of or resulting from performance of the work, provided that such claim, damage, loss, cost, or expense is attributable to bodily injury, sickness, disease or death, or to injury to or destruction of tangible property (other than the work itself) caused or alleged to be caused by the negligent acts, negligent omissions, and/or fault of

the County or the County's consultants, agents, representatives, or employees and arises out of this project and provided such claim, damage, loss, cost, or expense is not caused by the sole negligence of a party indemnified hereunder."

13. ROYALTIES AND PATENTS

The Contractor shall pay all royalties and license fees. He shall defend all suits or claims for infringement of any patent rights and shall hold the County harmless from loss on account thereof.

14. PLANS AND SPECIFICATIONS

In carrying out the Work, the plan(s) and the specifications will be followed by the Contractor. Minor alterations in the plan may be made or permitted by the County Engineer from time to time and, if no additional Work is necessary, there will be no additional charge for carrying out such minor alterations.

The Contractor shall provide the County Engineer a set of reproducible as-built drawings upon completion of the Project. The Contractor shall maintain an updated construction progress plan in the Project field office at all times.

When applicable, The New Jersey Department of Transportation Standard Specifications for Road and Bridge Construction, as amended, and Supplemental Specifications for State Aid Projects, herein after referred to as the "Standard Specifications", are made a part of these specifications and contract for the improvements, and will govern the construction of this Project, the material used and the execution of this Project, except as revised and modified herein. The references to these specifications are given herein for the purpose of aiding in the rapid location of the description of the various items herein specified. The entire Work must be carried on and completed to the satisfaction of the County. The Standard Specifications are amended as follows:

"Any reference to the Commissioner, Department, Department Laboratory, Engineer or Inspector should be redefined to be the County of Union".

15. GUARANTEE AGAINST DEFECTIVE WORK

Prior to final payment being made or before the release of the performance security required by Section 3 above, the Contractor and Surety shall execute and deliver to the County an original Maintenance Bond with an original signature and seal having a penal sum equal to:

- A) One hundred percent (100%) of the final adjusted Contract amount, if such amount is \$50,000.00 or less;

- B) Fifty percent (50%) of the final adjusted Contract amount, if such amount be greater than \$50,000.00 but less than \$250,000.00; and,
- C) Twenty-five percent (25%) of the final adjusted contract amount, if such amount is \$250,000.00 or more.

The Bond and Surety shall be satisfactory to the Union County Counsel. The Surety shall hold a Certificate of Authorization to do business in the State of New Jersey and shall conform to P.L. 1995 c.384, codified as N.J.S.A. 2A:44-143, 144. The Surety Disclosure Statement and Certification required by N.J.S.A. 2A: 44-143, 144, shall be attached to the Bond. Such Maintenance Bond shall remain in full force and effect for a period of one (1) year from the date of Final Completion. Such Maintenance Bond shall also provide that the Contractor and the Surety guarantee to replace for the said period of one (1) year from the date of Final Completion, all Work performed and/or all materials furnished that were not performed or were not furnished in accordance to the terms and performance requirements of the Contract Documents, and will make good any defects thereof which become apparent before the expiration of one (1) year. If, during that period, any part of the Project, in the judgment of the Engineer, is found defective, the Contractor will repair or replace same within five (5) days of receipt of notice from the County Engineer. If the Contractor refuses or neglects to do such Work in the time specified, the County Engineer may have the Work done by others and the Contractor or his Surety thereof will pay the cost.

The Contractor will furnish the County a Maintenance Bond for a percentage of the final adjusted contract price, as stated above. The one (1) year period will start the day of Final Completion of Project by the County. Final payment is conditional on the receipt of a maintenance bond in a form acceptable to County Counsel.

16. TRAFFIC AND STREET MAINTENANCE

The Work must be started and performed by the Contractor in such a manner as to minimize delays to the traveling public. It must be completed in a timely fashion, with little or no inconvenience to traffic and pedestrians, where such inconvenience may be avoided.

All municipal, county, and state roadways shall remain open to traffic unless otherwise provided for in the technical specifications.

If modified traffic patterns are authorized in order to provide a safe working or traveling environment, the Contractor is responsible for providing all equipment, barrels, cones, signs, and barricades to implement the work zone and detours, unless otherwise specified in the technical specifications. All work zones and detours shall be established in accordance with the technical plans and specifications if provided or in strict compliance with the current version of the Manual for Uniform Traffic Control Devices (MUTCD). The Contractor shall obtain approval for these work zones and

detour plans from the Municipal Police or applicable police agency and the Union County Bureau of Traffic Maintenance prior to implementation.

All traffic control plans shall provide for safe movement of vehicular, bicycle, and pedestrian traffic. Particular attention shall be given to requirements of the Americans with Disabilities Act.

No portion of any street or alleyway may be used for the storage of any materials or equipment without the approval of the Municipal Police or other applicable police agency. Sidewalks, gutters, drains, fire hydrants and private drives shall be maintained for their intended use unless specifically approved by the County Engineer.

Upon suspension of Work, at the end of the day or for protracted periods, the Contractor shall remove all rubbish and materials from the Work site to the approved storage/staging location. All road cuts, saw cuts, and trenches that may pose hazard to vehicular, pedestrian, or bicycle traffic, to include handicapped users, shall be filled to the surface of the roadway or sidewalk. At no time will steel plates or settled trenches be allowed at the daily suspension of Work, unless specifically approved by the County Engineer.

Use of Traffic Control Officers shall be determined by the County in accordance with the provisions of N.J.S.A. 40A:11-23.1(c). If applicable to the Project, the County shall have provided an allowance for same as set forth in the Bid Form.

With respect to pedestrian traffic, the Contractor shall install signs restricting access of the general public and, as necessary, Union County employees to the area of construction. The Contractor shall provide safe access to required areas and place physical barriers to restricted areas. These barriers may range from caution tape to actual barriers, at the direction of the County Engineer.

17. CONTRACTOR'S EMPLOYEES

The Contractor must employ only suitable and competent labor in the Work, and must remove from the Work any incompetent, unsuitable, or disorderly person upon complaint from the County Engineer.

The parties to any contract resulting from this proposal do hereby agree that the provisions of N.J.S.A. 10:2-1 through 10:2-4 (discrimination in employment on public works contracts): 34:11-56.25 et seq. (payment of prevailing rate of wages determined pursuant to N.J.S.A. 34:11-56.30 by the Commissioner), and the Rules and Regulations promulgated pursuant thereto, are hereby made a part of any contract and are binding upon them.

There will be no discrimination against any employee who is employed in the Work to be covered by any contract resulting from this bid because of age, race, creed, color, national origin, ancestry, marital status or sex.

Any person, firm, or corporation violating the provisions of this Section will be deemed and judged a disorderly person.

18. OWNERSHIP DISCLOSURES REQUIRED

Pursuant to P.L. 1977, N.J.S.A. 52:25-24.2, the Bidder shall submit with its Bid, or prior to receipt of bids, a statement setting forth the names and addresses of all stockholders in the corporation or partnership bidding who own ten percent (10%) or greater interest therein. (See forms attached)

19. NON-COLLUSION AFFIDAVIT

The Bidder shall submit with its bid either the attached completed "Non-Collusion Affidavit" or a statement of non-collusion with verbiage similar to same.

20. EQUAL EMPLOYMENT OPPORTUNITY COMPLIANCES

The successful bidder shall be required to complete and submit an Initial Project Workforce Report, New Jersey Department of Treasury Form AA-201, upon notification of award. Failure to submit this completed form may result in the Contract being terminated.

The successful bidder shall also be required to submit a copy of its Monthly Project Workforce Report, New Jersey Department of Treasury Form AA-202, to the New Jersey Department of Treasury's Division of Public Contracts Equal Employment Opportunity Compliance and to the Board.

21. COMPLIANCE WITH NEW JERSEY PREVAILING WAGE ACT

The County of Union, in order to fulfill the requirements of N.J.S.A. 34:11-56a.25 et seq, requires that the following additional conditions be strictly followed. The bidders represent that he is not listed or is not on record in the Office of the Commissioner or the Department of Labor and Industry as one who failed to pay prevailing wages in accordance with the provisions of this Act. The bidder agrees to the inclusion of a contract provision upon award which specifically requires said Contractor to fully comply with each and all of the requirements of the aforesaid Act as it relates to prevailing rates of wages on public contracts as set forth in the New Jersey Prevailing Wage Act, P.L. 1963, Chapter 150 and P.L. 1974, Chapter 64.

A Copy of the Prevailing Wage Rates is attached for your reference. Applicable rates are those wages and fringe benefit rates in effect on the date the contract is awarded. All predetermined rate increases listed at the time the contract award must also be paid, beginning on the dates specified. Rates may change between the time of issuance of this determination and the award of the public works contract. Therefore, prior to the award of the contract, verification must be made with the Public Contracts section, to insure that the rates contained in this determination are still prevailing.

The Contractor agrees to abide and be bound by each and all of the said statutory provisions with respect to the payment of prevailing rates of wages, and acknowledges that the County reserves the right to terminate the Contractor's (or his subcontractors') right to proceed with the scope of Work, or such portion thereof that relates to the failure to pay prevailing rates of wages. In such event or under the terms of N.J.S.A. 34:11-56.27, the Contractor and his surety will be liable to the County of Union for any excess costs occasioned by such a violation.

The Contractor or subcontractors for this Project will post the Prevailing Wage Rates for each craft and classification involved as determined by the Commissioner of Labor and Industry, including the effective date of any changes thereof, in prominent and easily accessible places at the site of the Work or at such place or places as are used by them to pay workmen their wages.

The County of Union requires a copy of payroll records from the Contractor and subcontractors. Payroll records shall be submitted with each voucher request for payment. Prevailing wage rates may be obtained from the New Jersey Labor, Division of Workplace Standards, Public Contracts Section, (609-292-2259).

In addition to compliance with the New Jersey Prevailing Wage Act, the County requires compliance with procedures established by Resolution No. 2014-0408 adopted by the Union County Board of Chosen Freeholders on May 8, 2014. The resolution is furnished in Section 51 of these General Specifications.

UNION LABOR IS PREFERRED ON ALL COUNTY WORK

The foregoing reference to specific laws will not be deemed to be a limitation of obligation of the Contractor to perform his obligations in full compliance with the provisions and requirements of all federal and state statutes and local ordinances applicable to the Work to be done under the contract.

It is agreed and understood that any contracts and/or orders placed as a result of this proposal will be governed and construed and the rights and obligations of the parties hereto will be determined in accordance with the laws of the State of New Jersey.

Upon completion of the Work, the Contractor will furnish a Certification of Compliance with the New Jersey Prevailing Wage Act. The certificate in a form acceptable to County Counsel is a condition of the final payment. (See form attached)

22. BRAND NAME OR EQUAL

When the Specifications, Forms, and other Contract Documents use “brand name or equivalent” or similar language, the listed brand name shall serve as a reference or point of comparison for the functional or operational characteristic desired for the goods or services being requested. Where a bidder attempts to submit an equivalent product for a brand name, it shall be the responsibility of the bidder to fully describe and document the product to be provided with the bid in order to establish the equivalence claim.

- A. If the Bidder proposes to offer substitute goods as an equal to those specified herein, the bidder shall so indicate with the Bid Proposal. For the purposes of this paragraph, a proposed item shall be considered equal to goods specified herein if:
 - 1. The County, in its sole discretion, determines that: (i) the goods conform substantially, even with deviations, to the brand name goods specified herein; (ii) the goods are equal to or greater than the brand name goods specified herein in terms of quality, durability, functionality, appearance, strength and design; (iii) the goods are capable, at least as well as the brand name goods specified herein, or performing with existing equipment; and (iv) the goods do not cost the County more than the brand name goods specified herein costs the County.

- B. To offer substitute goods as an equal to those specified herein, it is necessary that:
 - 1. The Bidder submits sufficient information with its bid to permit the County to determine that the goods are equivalent to the brand name goods specified herein, including, but not necessarily limited to the brand, catalog number and specifications/data sheets;
 - 2. The Bidder fully identifies and describes the variations of the goods from the brand name goods specified herein on a separate sheet that is to be submitted with the bid proposal. Bidder’s literature WILL NOT suffice in explaining exceptions to these specifications.

3. The Bidder certifies that the goods (i) are similar in substance to the brand name goods specified, and (ii) are suited to the same use as the item specified;
- C. The County shall be allowed a reasonable time within which to evaluate the Bidder's proposal to offer substitute goods as an equal to those specified herein. The County shall be the sole judge of acceptability. No "or-equal" goods shall be ordered, delivered, assembled, set-up or utilized until the County's evaluation is complete. The County's determination as to equivalency shall be deemed final and absolute.

In the event the Bidder does not provide sufficient supporting documentation with the bid, it will be presumed and required that the brand name goods and services as described in the specifications will be provided.

23. LINES AND GRADES

Normally, horizontal and vertical control points will be provided in the technical specifications. All other surveying will be the responsibility of the Contractor unless otherwise noted.

24. NUMBER OF WORKING DAYS

In accordance with NJSA 40A:11-17, the Work for the within Project shall be completed as specified on the Time of Completion Form. See form attached

There shall be taken a deduction from the contract price, or any wages paid by the County, to any inspector(s) necessarily employed by it on the Work, for any number of days in excess of the number allowed in the specifications.

25. PROMPT PAYMENT OF CONSTRUCTION CONTRACTS (NJ Prompt Payment Act)

Pursuant to NJSA 2A:30A-1 et. seq., payment to the Contractor, other than for Work done pursuant to a contact allowance, where applicable, shall be processed and paid as follows:

1. All contractor bills shall be either approved for payment, or notice provided as to why the bill or any portion of it will not be approved by the representative(s) of the governing body no later than the public meeting following 20 calendar days of the billing date as defined in the statute.

2. If the billing is approved, said bill shall be paid in the payment cycle following the meeting.

26. STOPPING WORK ON ACCOUNT OF BAD WEATHER

Work must only be performed in weather suitable for the type of construction planned or underway. Extremes in temperature, humidity, precipitation, evaporation, etc. can detrimentally affect the constructed product. Refer to the Standard and Technical Specifications for specific items.

27. ACCESS FOR OTHER CONTRACTORS

The Contractor for this Work will give proper access to other contractors who may be employed upon the Project and must not hinder or delay unnecessarily any Work that may be progressing under other contracts.

28. CONDEMNED MATERIALS AND WORK

Any materials and or part of the Work that may be condemned by the County Engineer will be removed and replaced by the Contractor or otherwise rectified, as may be directed by the County Engineer. No payment will be made upon the Work until such faulty work has been made good as may be directed. In the event the Contractor refuses or neglects to make good such faulty work, he will be deemed to have abandoned the contract and proceedings may be taken against him as provided herein.

29. STORAGE

In the event that it is necessary for the Contractor to stockpile or store materials or equipment on the job site, the Contractor shall inform the County of such necessity and the County may offer available space, if any, for storage of such materials or equipment. The Contractor shall use said space only for such purpose. Any and all materials which may be stored in such space or which may be brought onto the job site at any time by the Contractor will be at the Contractor's sole risk. The County will not be responsible for loss of or damage to said materials or equipment for any cause whatsoever. The Contractor shall take necessary measures to protect any such storage area and shall be responsible for any and all damages.

30. FINAL CLEAN UP

Upon completion of the Work, the Contractor will remove all equipment, unused materials, rubbish, etc., and will repair, or replace in an a manner acceptable to the County Engineer, all areas that may have been damaged in the prosecution of the Work. Same shall be a condition precedent to final payment. Should said Contractor

fail to comply with this requirement, the County shall undertake the clean-up with its own forces and charge the cost of same against the Contractor's contract balance.

31. SUB-LETTING OF WORK

Except for the List of Subcontractors, pursuant to NJSA 40A:11-16 (See form attached), no portion of the Work will be sublet by the Contractor to any other entities, except with the consent of the County Engineer. A complete list of subcontractors must be submitted to the County Engineer at the preconstruction meeting. If the job does not warrant a preconstruction meeting, the Contractor must submit such list prior to the start of Work.

All Subcontractors will be subject to NJSA 34:11-56 et al.

N.J.S.A. 40A:11-16 requires the bidder to list in the bid sheets the name or names of all subcontractors involved in the following types of Work: plumbing and gas fitting and all kindred work, steam and hot water heating, ventilating apparatus, steam power plants and kindred work, electrical work, ornamental iron work, and structural steel. In addition, the County may require the identification of specific additional subcontractors. If these trades are expected to be part of the contract, such subcontractors should be listed on the "Subcontractor Identification Statement List of Subcontractors" and Bidder shall certify same on the accompanying sheet titled "Subcontractor Identification Certification". (See forms attached) **Bidder's failure to submit these two forms shall be considered a material defect and result in rejection of Bidder's bid.** Substitutions of any listed subcontractors pursuant to NJSA 40A:11-16 will not be permitted except with the consent of the County Engineer.

32. SAFETY

The Contractor shall observe all rules and regulations of the Federal, State, and local health officials. Attention is directed to Federal, State, and local laws, rules, and regulations concerning construction safety and health standards. The Contractor shall not require any worker to work in surroundings or under conditions that are unsanitary, hazardous, or dangerous to the worker's health or safety.

The Contractor shall admit to the site, without delay and without the presentation of an inspection warrant, any inspector of OSHA or other legally responsible agency involved in safety and health administration upon presentation of proper credentials.

The Contractor shall make available to the Contractor's employees, subcontractors, the County Engineer, and the public, all information pursuant to OSHA 29 CFR Part 1926.59 of The Hazard Communication Standard 29 CFR 1910.1200, and shall also maintain a file on each job site containing all Material Safety Data Sheets (MSDS) for products in use at the Project. These Material Safety Data Sheets shall be made available to the Engineer upon request.

The Contractor shall at all times conduct the Work to provide for the safety and convenience of the general public and protection of persons and property. The safety provisions of applicable laws, OSHA regulations, building and construction codes, and the rules and regulations of the New Jersey Department of Labor and Commerce shall be observed.

33. QUALITY, SAFETY AND PERFORMANCE STANDARDS

All goods and services must be constructed and provided with the highest quality materials and workmanship. It is the intent of these specifications that only equipment equal to, or exceeding, the standard specified will be acceptable in order to protect the safety of the occupants of the Building.

34. MATTERS NOT MENTIONED IN CONTRACT DOCUMENTS

Any Work, material, or method, not specifically described in these specifications, but shown upon the plans of the Work, will be carried out as shown on said plan.

35. PERMITS

The Contractor will obtain all necessary permits required by law and provide the County with necessary approvals prior to commencement of permitted Work.

36. CONTRACTOR TO PROVIDE PROOF OF PAYMENT

Upon the completion of the Work, the Contractor will furnish a General Release as proof that all claims for labor, materials, etc., have been settled by the Contractor. The General Release, in a form acceptable to County Counsel, is a condition of final payment.

37. CHANGE ORDERS

Change Order Procedures shall comply with *N.J.A.C. 5:30-11.1 et seq.*, "Change Orders and Open End Contracts" and subsequent provisions of the New Jersey Administrative Code.

38. SUPPLEMENTAL WORK

In case any supplemental work is necessary, it will be performed by the Contractor at a price fixed by agreement between the Contractor and the County Engineer and approved by the County as specified in Section 36. The Contractor will do no supplemental work on any character, for which the Contractor will demand pay, except upon the written order of the County.

39. FORM OF CONTRACT

The Contract will be subject to all statutory provisions on the matter of Public Works, Public Contracts, The Law Against Discrimination, the Laws Governing Affirmative Action and Prevailing Rates of Wages under the laws of New Jersey.

The Agreements shall be executed by both parties not later than twenty-one (21) days from the date of the award by the County (Sundays and holidays excluded); however, such time frame may be extended by agreement of the parties.

40. PROGRESS PAYMENTS

Monthly progress payments will be made based on the value of labor and materials incorporated in the Work and of materials suitably stored at the site. An itemized schedule of values shall be submitted with each Application for Payment.

(Refer to the Owner/Contractor Agreement for Retainage and other conditions pertaining to payment and the application of NJSA 2A:30A-1 et. seq.)

All Applications for Payment shall be accompanied by paid invoices for materials incorporated in the Work and for materials suitably stored at the site, and affidavit(s) by Subcontractors whose Work was included in the next to the last application to the effect such Work and such materials have been paid for.

No payment shall be made without Contractor having provided all submittals set forth in this Section, and the approval of same by the County.

For contracts exceeding \$100,000.00, monthly payments will be made on the Work to the extent of 98% of the value of the Work done which is considered to be retainage.

For contracts less than \$100,000.00, monthly payments will be on the Work to the extent of 90% of the value of the Work done. In lieu of the retainage, the Contractor will, at his option, deposit with the County Counsel negotiable bearer bonds of the State of New Jersey or any political subdivision thereof, equal to the amount otherwise withheld as retainage.

When the Project is completed, the final cost of the Project will be based on actual quantities of authorized Work done under each item scheduled in the bidding sheet and approved Change Orders, if any. The money due to the Contractor as determined by said final certificate after deduction of previous monthly payments on account, will be paid to the Contractor in accordance with the terms of the contract dealing with Prompt Payment, providing, however that before such final payment is made, all outstanding claims against the Contractor must be satisfied. Before final

payment is released, the Contractor must furnish: **a)** Maintenance Bond (see Section 6 of these general specifications); **b)** Certification of Compliance, New Jersey Prevailing Wage Act (see Sections 21 and 51); and **c)** General Release (see Section 36) in a form satisfactory to County Counsel; **d)** complete set of as-built plans in the latest AutoCad on compact disc; and e) a complete set of in-progress photos in jpg, jpeg, or bmp digital format on a compact disc.

41. INSPECTION

The Work must be done in accordance with the plans and specifications, and will be inspected by the County Engineer. An inspector may be placed upon the Work at any time by the County Engineer to see that the plans, specifications, and instructions of the County Engineer are carried out. In connection herewith, bidders are referred to N.J.S.A. 40A:11-17.

42. DAMAGES

The Contractor will be held responsible for all damages that may occur to Work, or to persons or property by reason of the nature of the Work or from the elements, or by reason of inadequate protection of the Work, or from any carelessness or negligence on his part or on the part of his employees. The County will withhold payments on the Work until all suits or claims for damages sustained on, or by reason of, this Work will have been settled by the Contractor.

The construction and final completion of this Work will be guaranteed by the Contractor. Any damages that may be done to the Work or any part thereof, by the elements or otherwise, during its construction, will be made good by the Contractor.

43. LIQUIDATED DAMAGES

If the Project is not completed within the time specified herein or within such further time as may have been granted by the County Engineer, then the Contractor hereby agrees to pay to the County as liquidated damages, but not as a penalty, \$1,000.00 per day for each and every calendar day that he is in default on time to complete the Work. The said sum will be deducted from moneys due the Contractor and if the damages exceed this amount, then the Contractor or his Surety Company will pay the excess. These damages may be waived at the option of the County.

44. AFFIRMATIVE ACTION REQUIREMENTS

EXHIBIT B (Revised 4/10)

MANDATORY EQUAL EMPLOYMENT OPPORTUNITY LANGUAGE N.J.S.A. 10:5-31 et seq. (P.L. 1975, C. 127) N.J.A.C. 17:27

CONSTRUCTION CONTRACTS

During the performance of this contract, the contractor agrees as follows:

The contractor or subcontractor, where applicable, will not discriminate against any employee or applicant for employment because of age, race, creed, color, national origin, ancestry, marital status, affectional or sexual orientation, gender identity or expression, disability, nationality or sex. Except with respect to affectional or sexual orientation and gender identity or expression, the contractor will ensure that equal employment opportunity is afforded to such applicants in recruitment and employment, and that employees are treated during employment, without regard to their age, race, creed, color, national origin, ancestry, marital status, affectional or sexual orientation, gender identity or expression, disability, nationality or sex. Such equal employment opportunity shall include, but not be limited to the following: employment, up-grading, demotion, or transfer; recruitment or recruitment advertising; layoff or termination; rates of pay or other forms of compensation; and selection for training, including apprenticeship. The contractor agrees to post in conspicuous places, available to employees and applicants for employment, notices to be provided by the Public Agency Compliance Officer setting forth provisions of this nondiscrimination clause.

The contractor or subcontractor, where applicable will, in all solicitations or advertisements for employees placed by or on behalf of the contractor, state that all qualified applicants will receive consideration for employment without regard to age, race, creed, color, national origin, ancestry, marital status, affectional or sexual orientation, gender identity or expression, disability, nationality or sex.

The contractor or subcontractor will send to each labor union, with which it has a collective bargaining agreement, a notice, to be provided by the agency contracting officer, advising the labor union or workers' representative of the contractor's commitments under this act and shall post copies of the notice in conspicuous places available to employees and applicants for employment.

The contractor or subcontractor, where applicable, agrees to comply with any regulations promulgated by the Treasurer, pursuant to N.J.S.A. 10:5-31 et seq., as amended and supplemented from time to time and the Americans with Disabilities Act.

When hiring or scheduling workers in each construction trade, the contractor or subcontractor agrees to make good faith efforts to employ minority and women workers in each construction trade consistent with the targeted employment goal prescribed by N.J.A.C. 17:27-7.2; provided, however, that the Division may, in its discretion, exempt a contractor or subcontractor from

compliance with the good faith procedures prescribed by the following provisions, A, B and C, as long as the Division is satisfied that the contractor or subcontractor is employing workers provided by a union which provides evidence, in accordance with standards prescribed by the Division, that its percentage of active "card carrying" members who are minority and women workers is equal to or greater than the targeted employment goal established in accordance with N.J.A.C. 17:27-7.2. The contractor or subcontractor agrees that a good faith effort shall include compliance with the following procedures:

(A) If the contractor or subcontractor has a referral agreement or arrangement with a union for a construction trade, the contractor or subcontractor shall, within three business days of the contract award, seek assurances from the union that it will cooperate with the contractor or subcontractor as it fulfills its affirmative action obligations under this contract and in accordance with the rules promulgated by the Treasurer pursuant to N.J.S.A. 10:5-31 et. seq., as supplemented and amended from time to time and the Americans with Disabilities Act. If the contractor or subcontractor is unable to obtain said assurances from the construction trade union at least five business days prior to the commencement of construction work, the contractor or subcontractor agrees to afford equal employment opportunities minority and women workers directly, consistent with this chapter. If the contractor's or subcontractor's prior experience with a construction trade union, regardless of whether the union has provided said assurances, indicates a significant possibility that the trade union will not refer sufficient minority and women workers consistent with affording equal employment opportunities as specified in this chapter, the contractor or subcontractor agrees to be prepared to provide such opportunities to minority and women workers directly, consistent with this chapter, by complying with the hiring or scheduling procedures prescribed under (B) below; and the contractor or subcontractor further agrees to take said action immediately if it determines that the union is not referring minority and women workers consistent with the equal employment opportunity goals set forth in this chapter.

(B) If good faith efforts to meet targeted employment goals have not or cannot be met for each construction trade by adhering to the procedures of (A) above, or if the contractor does not have a referral agreement or arrangement with a union for a construction trade, the contractor or subcontractor agrees to take the following actions:

(1) To notify the public agency compliance officer, the Division, and minority and women referral organizations listed by the Division pursuant to N.J.A.C. 17:27-5.3, of its workforce needs, and request referral of minority and women workers;

(2) To notify any minority and women workers who have been listed with it as awaiting available vacancies;

(3) Prior to commencement of work, to request that the local construction trade union refer minority and women workers to fill job openings, provided the contractor or subcontractor has a referral agreement or arrangement with a union for the construction trade;

(4) To leave standing requests for additional referral to minority and women workers with the local construction trade union, provided the contractor or subcontractor has a referral agreement or arrangement with a union for the construction trade, the State Training and Employment Service and other approved referral sources in the area;

(5) If it is necessary to lay off some of the workers in a given trade on the construction site, layoffs shall be conducted in compliance with the equal employment opportunity and non-discrimination standards set forth in this regulation, as well as with applicable Federal and State court decisions;

(6) To adhere to the following procedure when minority and women workers apply or are referred to the contractor or subcontractor:

(i) The contractor or subcontractor shall interview the referred minority or women worker.

(ii) If said individuals have never previously received any document or certification signifying a level of qualification lower than that required in order to perform the work of the construction trade, the contractor or subcontractor shall in good faith determine the qualifications of such individuals. The contractor or subcontractor shall hire or schedule those individuals who satisfy appropriate qualification standards in conformity with the equal employment opportunity and non-discrimination principles set forth in this chapter. However, a contractor or subcontractor shall determine that the individual at least possesses the requisite skills, and experience recognized by a union, apprentice program or a referral agency, provided the referral agency is acceptable to the Division. If necessary, the contractor or subcontractor shall hire or schedule minority and women workers who qualify as trainees pursuant to these rules. All of the requirements, however, are limited by the provisions of (C) below.

(iii) The name of any interested women or minority individual shall be maintained on a waiting list, and shall be considered for employment as described in (i) above, whenever vacancies occur. At the request of the Division, the contractor or subcontractor shall provide evidence of its good faith efforts to employ women and minorities from the list to fill vacancies.

(iv) If, for any reason, said contractor or subcontractor determines that a minority individual or a woman is not qualified or if the individual qualifies as an advanced trainee or apprentice, the contractor or subcontractor shall inform the individual in writing of the reasons for the determination, maintain a copy of the determination in its files, and send a copy to the public agency compliance officer and to the Division.

(7) To keep a complete and accurate record of all requests made for the referral of workers in any trade covered by the contract, on forms made available by the Division and submitted promptly to the Division upon request.

(C) The contractor or subcontractor agrees that nothing contained in (B) above shall preclude the contractor or subcontractor from complying with the union hiring hall or apprenticeship policies in any applicable collective bargaining agreement or union hiring hall arrangement, and, where required by custom or agreement, it shall send journeymen and trainees to the union for referral, or to the apprenticeship program for admission, pursuant to such agreement or arrangement. However, where the practices of a union or apprenticeship program will result in the exclusion of minorities and women or the failure to refer minorities and women consistent with the targeted county employment goal, the contractor or subcontractor shall consider for employment persons referred pursuant to (B) above without regard to such agreement or arrangement; provided further, however, that the contractor or subcontractor shall

not be required to employ women and minority advanced trainees and trainees in numbers which result in the employment of advanced trainees and trainees as a percentage of the total workforce for the construction trade, which percentage significantly exceeds the apprentice to journey worker ratio specified in the applicable collective bargaining agreement, or in the absence of a collective bargaining agreement, exceeds the ratio established by practice in the area for said construction trade. Also, the contractor or subcontractor agrees that, in implementing the procedures of (B) above, it shall, where applicable, employ minority and women workers residing within the geographical jurisdiction of the union.

After notification of award, but prior to signing a construction contract, the contractor shall submit to the public agency compliance officer and the Division an initial project workforce report (Form AA 201) electronically provided to the public agency by the Division, through its website, for distribution to and completion by the contractor, in accordance with N.J.A.C. 17:27-7. The contractor also agrees to submit a copy of the Monthly Project Workforce Report once a month thereafter for the duration of this contract to the Division and to the public agency compliance officer.

The contractor agrees to cooperate with the public agency in the payment of budgeted funds, as is necessary, for on-the-job and/or off-the-job programs for outreach and training of minorities and women.

(D) The contractor and its subcontractors shall furnish such reports or other documents to the Division of Public Contracts Equal Employment Opportunity Compliance as may be requested by the Division from time to time in order to carry out the purposes of these regulations, and public agencies shall furnish such information as may be requested by the Division of Public Contracts Equal Employment Opportunity Compliance for conducting a compliance investigation pursuant to **Subchapter 10 of the Administrative Code (NJAC 17:27)**.

[REMAINDER OF PAGE INTENTIONALLY LEFT BLANK]

45. INVESTMENT ACTIVITIES IN IRAN

Pursuant to P.L. 2012, c.25, codified as NJSA 2:32-55 *et seq*, prohibits State and local public contracts with persons or entities engaging in certain investment activities in energy or finance sectors of Iran.

46. COMPLIANCE WITH THE PUBLIC WORKS CONTRACTOR REGISTRATION ACT - (NJSA 34:11-56.48 *et. seq.*)

Pursuant to the above-referenced law, Bidders are required to be registered with the New Jersey Department of Labor and to possess a current certificate by said Department indicating compliance with the Act prior to the time and date that bids are received. Bidders are notified of this requirement of their compliance. Such certificates or applications shall also be provided for each Subcontractor furnishing plumbing and gas fitting, steam and hot water heating and ventilating apparatus, and all kindred work, steam power plants and kindred work, electrical work, structural steel and ornamental iron work, and such other subcontractors as the specifications require relative to prior identification.

47. UTILITIES

Attention of the bidder is directed to the fact that the approximate locations of known utility structures and facilities that may be encountered within and adjacent to the limits of the Work are shown on the plans and described herein. The accuracy and completeness of this information is not guaranteed by the County Engineer and the bidder is advised to ascertain for himself all the facts concerning the location of these and other utilities.

The Contractor will not proceed with his Work until he has made diligent inquiries of all public utility and municipal officials to determine the exact location of all underground structures and pipes within the site of the Project. The Contractor will notify utility owners not less than ten (10) days in advance of the time he proposes to perform any Work that will endanger or affect their facilities in compliance with **New Jersey One-Call**. In excavating in any part of the Work, care must be taken not to remove or damage any gas, water, sewer, or other pipe, conduit, or structure, - public or private - without the concurrence of the owner and the County Engineer. The Contractor will, at his own expense, shore up, secure and maintain a continuous flow in such structures, and will keep them in repair until final acceptance of the Work.

When pipes or other structures are encountered or when the removal, relocation or protection of these utilities are necessary in carrying out the Project as planned, the Contractor will cooperate with the owner of said utilities and will permit the owners or their agents access to the site of the Work in order to relocate or protect their facilities

and not hinder or delay unnecessarily the Work of the owners in moving same. No extra allowance of payment will be made to the Contractor for the use of any materials, equipment, etc., or for the performance of any Work in connection with the moving of said structures unless the Contractor is specifically ordered by the County Engineer to furnish such materials, equipment, or services. If directed by the County Engineer to do any Work or furnish any materials or equipment, payment will be allowed the Contractor in accordance with the unit prices bid for such Work, or, if such items are not scheduled in the proposal, such Work shall be allowed "Supplemental Work" as provided in Section 39 of these general specifications. The corporations, companies, agencies or municipalities owning or controlling the utilities, and the name, and telephone numbers are listed in the beginning of the Technical Specifications.

48. MATERIAL COMPLIANCE AND SHOP DRAWINGS

The Contractor will require the manufacturer or supplier to furnish three (3) copies of Certification of Compliance with each delivery of materials, components and manufactured items for the Project. Two (2) copies will be furnished to the County Engineer; one copy will be retained by the Contractor. Certificates of Compliance will contain the following information:

1. Project to which material is consigned;
2. Name of the Contractor to which the material is supplied;
3. Kind of material supplied;
4. Quantity of material represented by the Certificate;
5. Means of identifying the consignment, such as label marking, seal number, etc.;
6. Date and method of shipment;
7. That the material is in conformity with the pertinent specifications stated in the certificate; and
8. Signature of a person having legal authority to bind the supplier.

The Contractor will submit to the County Engineer for his approval five (5) copies of complete and fully detailed shop or working drawings for those items listed in the beginning of the technical specifications.

Each drawing will identify the name of the job, location and Contractor.

All drawings will be approved in accordance with the standard specifications. Refer to the Technical Specifications for specific items.

All materials or articles used in the Work will be of American manufacture, insofar as same are available, in conformance with N.J.S.A. 40A:11-18.

49. PRECONSTRUCTION

In order to provide full coordination of this Project among the parties concerned, the County Engineer will arrange for a preconstruction meeting between the Contractor, County Engineer and other interested parties as soon as possible after the contract is executed. At this meeting the Contractor will present his proposed schedule of Work which shall be subject to review and approval of the County through its designated representatives.

50. DISPUTES UNDER THE CONTRACT

A dispute arising under the Contract shall be submitted in writing to the County Engineer with all facts and supporting data. The County Engineer will review the dispute and issue his decision or request additional facts or documentation after which he will render his decision.

In the event the dispute is not then resolved, the matter shall, pursuant to law, be submitted to mediation before being submitted to a court of competent jurisdiction venued in Union County.

The County Engineer will notify the County Counsel when a matter is to be submitted to mediation. The County Counsel will communicate with the parties and inform them of the procedures to be followed in making such a submission.

[REMAINDER OF PAGE INTENTIONALLY LEFT BLANK]

51. CONTRACTOR BUSINESS REGISTRATION CERTIFICATE New Mandatory Requirement -Effective 1/18/2010

The recently enacted **P.L. 2009, c.315**, requires that effective January 18, 2010; a contracting agency must receive proof of the bidder's business registration prior to the award of a contract. However, the proof must show that the bidder was in fact registered with the State of New Jersey Department of the Treasury, Division of Revenue and obtained the business registration prior to the receipt of bids.

If subcontractors are named on the bid, proof of the business registration for each subcontractor must be provided prior to the award of bid. Similarly to the bidder, the proof must show that each subcontractor was registered with the State of New Jersey Department of the Treasury, Division of Revenue and obtained the business registration prior to the receipt of bids.

Proof of business registration shall be

- A copy of a Business Registration Certificate issued by the Department of the Treasury, Division of Revenue; or
- A copy of the web version provided by the NJ Division of Revenue, or

Register online at <http://www.state.nj.us/treasury/revenue/busregcert.htm>. Click the "online" link and then select "Register for Tax and Employer Purposes or call the Division at 609-292-1730.

Note: A NJ Certificate of Authority is not acceptable.

FAILURE to submit proof of registration of the bidder or any subcontractor named on the bid prior to the award of contract shall be cause to reject the bid.

FAILURE of the bidder or any subcontractor named on the bid to be registered prior to the receipt of bids is cause for a **MANDATORY REJECTION** of bids. (A NON-WAIVABLE DEFECT). This covers construction Work as well as non-construction bids.

IN ADDITION:

N.J.S.A. 52:32-44 imposes the following requirements on Contractors and all subcontractors that knowingly provide goods or perform services for a Contractor fulfilling this contract:

- 1) the Contractor shall provide written notice to its subcontractors and suppliers to submit proof of business registration to the Contractor;
- 2) subcontractors through all tiers of a project must provide written notice to their subcontractors and suppliers to submit proof of business registration and subcontractors shall collect such proofs of business registration and maintain them on file;

- 3) prior to receipt of final payment from a contracting agency, the Contractor must submit to the contacting agency an accurate list of all subcontractors and suppliers or attest that none was used; and,
- 4) during the term of this contract, the Contractor and its affiliates shall collect and remit, and shall notify all subcontractors and their affiliates that they must collect and remit, to the Director, New Jersey Division of Taxation, the use tax due pursuant to the Sales and Use Tax Act, (*N.J.S.A. 54:32B-1 et seq.*) on all sales of tangible personal property delivered into this State.

A Contractor, subcontractor or supplier who fails to provide proof of business registration or provides false business registration information shall be liable to a penalty of \$25 for each day of violation, not to exceed \$50,000 for each business registration copy not properly provided or maintained under a contract with a contracting agency. Information on the law and its requirements are available by calling (609) 292-9292.

[REMAINDER OF PAGE INTENTIONALLY LEFT BLANK]

52. BID PROTEST – LEGAL FEES AND COSTS

In the event a Bidder unsuccessfully challenges a Bid Submission by filing an action in a court of law concerning same, said Bidder shall be responsible for payment of reasonable legal costs and fees incurred by the County relating to said protest.

53. AMERICAN GOODS AND PRODUCTS WHERE POSSIBLE

Bidder shall comply with the requirements of NJSA 40A:11-18 and use only manufactured and farm products of the United States, wherever available, for the Project.

54. NEW JERSEY PAY-TO-PLAY REQUIREMENTS

This Contract is required by law to be publicly advertised for bids. As such, lists of political contributions pursuant to NJSA 19A:44A-1 et. seq. are NOT REQUIRED to be provided with the bids.

55. STATEMENT OF EQUIPMENT TO BE USED IN CONSTRUCTION

Pursuant to NJSA 40A:11-20 entitled Certificate of Bidder Showing Ability to Perform Contract, the County requires a Certification from all bidders submitting a bid showing that the Bidder owns, leases, or controls all necessary equipment required by the Project Plans and Specifications. All bidders shall provide this information at the time of the bid opening using the attached form entitled, "CERTIFICATE OF BIDDER SHOWING ABILITY TO PERFORM CONTRACT".

If the Bidder is not the actual owner of the equipment, it shall state the source from which the equipment will be obtained and shall attach a certificate from the owner or person in control of the equipment demonstrating that the equipment owner has granted the Bidder control of the requisite equipment during such time as may be necessary for completion of the portion of the contract for which the equipment is necessary.

56. NEW JERSEY SALES AND USE TAX REQUIREMENTS,

Contractors are required to comply with the following:

New Jersey Sales and Use Tax Requirements: All contractors with subcontractors, or any of their affiliates, who enter into contracts for the provision of goods or services with or for New Jersey local government entities, are required to collect and remit to the New Jersey Director of Taxation in the Department of the Treasury the use tax due on all of their sales of tangible personal property delivered into the State of New Jersey pursuant to the "Sales and Use Tax Act," (NJSA 54:32B-1 et. seq.),

regardless of whether the tangible personal property is intended for a contract with the contracting agency. This tax shall be remitted for the term of the Contract.

For purposes herein "affiliate" shall mean any entity that: (a) directly, indirectly, or constructively controls another entity, (b) is directly, indirectly, or constructively controlled by another entity, or (c) is subject to the control of a common entity. For purposes of the immediately preceding sentence, an entity controls another entity if it owns, directly or indirectly, more than fifty percent (50%) of the ownership interest in that entity. NJSA 52:32-44(g)(3).

ALFRED J. FAELLA
COUNTY MANAGER

LAURA M. SCUTARI, QPA, MPA
DIRECTOR / DIVISION OF PURCHASING

BID DOCUMENT SUBMISSION CHECKLIST

ALL SIGNATURES AND SEALS SHALL BE ORIGINALS UNLESS OTHERWISE SPECIFIED
BID SHEETS SHOULD NOT BE SUBMITTED DOUBLE SIDED PAGES, (SINGLE SIDE ONLY)

EACH BIDDER SHOULD COMPLETE THIS FORM AND INITIAL EACH ENTRY.

DATE COMPLETED: _____

PLEASE SUBMIT BID DOCUMENTS ON SINGLE SIDED PAPER ONLY, WITH THE EXCEPTION OF THE SURETY AND BID BOND DOCUMENTS.

IN ACCORDANCE WITH THE BID SPECIFICATIONS I HAVE REVIEWED, COMPLETED / EXECUTED AND INCLUDED THE FOLLOWING FORMS:

_____ Bid Form Page (**Signed, Dated and Bid on all alternatives applicable to the Work**).

_____ Security in the form of:

- _____ Bid bond in an amount equal to 10% of the total amount of this bid not to exceed \$20,000.00; or
- _____ Certified check or cashier's check in the amount of 10% of this bid not to exceed \$20,000.00

_____ Consent of Surety form signed by a Surety Company if the total amount of your Bid is over \$36,000.00. If your bid is accepted, the Surety Company that provided the Consent shall be required to furnish a Performance, Labor and Materials Bond in the amount of 100% of the award of the contract. The County of Union has provided its Consent of Surety form for your use. The use of this form by your Surety Company will expedite the bid review process and eliminate the possibility of having your bid rejected. If, however, you should need to use another form, please use language similar to that used on the Union County form and avoid making any additions or deletions to the Union County form language. In lieu of the Consent of Surety you may submit a Certified Check in the full amount of the bid.

_____ STATEMENT OF BIDDER OWNERSHIP. Pursuant to N.J.S.A. 52:25-24.2, which includes **BOTH** of the following documents:

- Bidder Signature Page
- Bidder Disclosure Statement (**Fill out 2 pages completely**)

_____ SUBCONTRACTOR IDENTIFICATION. Pursuant to N.J.S.A. 40A:11-16, which includes **BOTH** of the following documents:

- Subcontractor Identification Statement: List of Subcontractors (**only for certain types of work**)
- Subcontractor Identification Certification

_____ Acknowledgement of Addendum form: (**This form is to be used only when an addendum has been added to the specifications**).

_____ A copy of the State of New Jersey Department of the Treasury, Division of Revenue, **Business Registration Certificate ("BRC")** should be included with the bids as it must be received by the County prior to the award of the contract. The BRC provided must show that the Bidder was registered at the time of receipt of bids or the bid will be rejected.

_____ A copy of the State of New Jersey Department of the Treasury, Division of Revenue, **Business Registration Certificate ("BRC")** of all named or listed subcontractors (List of Subcontractors) in a Construction bid should be included with the bid as the BRC(s) must be received by the County prior to the award of the contract. Each subcontractor's certificate provided must show that the subcontractor was registered at the time of the receipt of bids or the bid will be rejected.

- _____ Affirmative Action Requirement
- _____ Experience Statement
- _____ Certificate of Bidder showing ability to perform Contract
- _____ Non-Collusion Affidavit – Fill out completely and notarize
- _____ Certificates from New Jersey Department of Labor – Public Works Contractor Registration Act. **(Only for certain types of work)**
- _____ Federal Attachments **(If applicable)**
- _____ NJDPMC Certificate / Notice of Classification **(If applicable)**
- _____ Americans with Disabilities Act
- _____ Statement of Bidder’s Qualifications
- _____ Contractor Performance Record
- _____ Affidavit Regarding List of Debarred, Suspended or Disqualified Bidders
- _____ Prior Negative Experience Questionnaire
- _____ Contractor’s Certification of Compliance – New Jersey Prevailing Wage Act
- _____ Uncompleted Contracts Affidavit **(For Bidder, if applicable) MUST ALSO PROVIDE DPMC FORM 701**
- _____ Certificate of Insurance Statement
- _____ Collection of Use Tax on Sales to Local Government Statement
- _____ Time of Completion
- _____ Disclosure of Investment Activities in Iran form

I HAVE TAKEN THE FOLLOWING ACTIONS:

- _____ Visited the site and attended the Pre-Bid Meeting **(Where applicable)**
- _____ Reviewed the Contract Documents (including any permits the County or its professionals may have obtained), Work, Site, Locality, and Local Conditions and Laws and Regulations that in any manner may affect Cost, Progress, Performance or Furnishing of Work.
- _____ Reviewed Bond Requirements
- _____ Provided Proof of Compliance with New Jersey Prevailing Wage Act
- _____ Reviewed Form of Owner/Contractor Agreement and General Conditions to the Contract

NOTE: QUESTIONS PERTAINING TO THIS BID ARE TO BE DIRECTED TO DIVISION OF ENGINEERING AT 908-789-3675

BIDDING DOCUMENTS

The Bidding Documents consist of the following items:

- **ADDENDA, if issued**
- **CLARIFICATIONS, if issued**
- **INSTRUCTION TO BIDDERS**
- **BID FORM**
- **SPECIFICATIONS:** **As outlined in the Table of Contents and included in the Project Manual.**
- **DRAWINGS:** **As per List of Drawings, indicated on the Project Title Sheet.**

Bidder's Name _____

BID FORM

I/We have carefully examined the plans, specifications, and advertisement for bid for the

**INTERSECTION IMPROVEMENTS AT CHESTNUT STREET AND FIFTH AVENUE
BOROUGH OF ROSELLE
COUNTY OF UNION, NEW JERSEY
BA#23-2017; UNION COUNTY ENGINEERING PROJECT #2016-020**

that is on file in the Union County Division of Engineering. I/We have inspected the site of the work and will contract to do all the work and furnish all materials mentioned in said plans and specifications. Work will be accomplished in the manner prescribed therein.

BASE BID ITEMS:

ITEM NO	DESCRIPTION	UNIT	CONTRACT QUANTITY	UNIT PRICE	AMOUNT
1	CONSTRUCTION LAYOUT	LS	1		
2	BREAKAWAY BARRICADE	UNIT	70		
3	DRUM	UNIT	135		
4	TRAFFIC CONE	UNIT	60		
5	CONSTRUCTION SIGNS	SF	660		
6	NO ITEM				
7	CLEARING SITE	LS	1		
8	EXCAVATION, TEST PIT	CY	4		
9	EXCAVATION, UNCLASSIFIED	CY	35		
10	DENSE GRADED AGGREGATE BASE COURSE, 4" THICK	SY	100		
11	HMA 9.5M64 SURFACE COURSE	TON	15		
12	HMA 19M64 BASE COURSE	TON	40		
13	CONCRETE SIDEWALK, 4" THICK	SY	130		
14	DETECTABLE WARNING SURFACE	SY	8		
15	10" X 20" CONCRETE VERTICAL CURB	LF	285		
16	TRAFFIC STRIPES, LONG-LIFE, THERMOPLASTIC	LF	3,000		
17	REMOVAL OF TRAFFIC STRIPES	LF	1,825		
18	REGULATORY AND WARNING SIGN	SF	50		
19	MAST ARM SIGN, TYPE DF	SF	22		
20	2 RIGID METALLIC CONDUIT, EARTH	LF	35		
21	4" SCHEDULE 80 PVC, EARTH	LF	185		
22	4" SCHEDULE 80 PVC, ROADWAY	LF	340		
23	18" X 36" JUNCTION BOX	UNIT	4		
24	24" X 36" JUNCTION BOX	UNIT	1		
25	FOUNDATION, TYPE SFT	UNIT	4		
26	FOUNDATION, TYPE P-MC	UNIT	1		
27	FOUNDATION, TYPE SPF	UNIT	4		
28	METER CABINET, TYPE T	UNIT	1		
29	SERVICE WIRE, NO. 6 AWG	LF	170		
30	GROUND WIRE, NO. 8 AWG	LF	445		

ITEM NO	DESCRIPTION	UNIT	CONTRACT QUANTITY	UNIT PRICE	AMOUNT
31	CONTROLLER ASSEMBLY, 12 PHASE WITH BATTERY BACKUP SYSTEM	UNIT	1		
32	UC-SMA15-TB2-2 SINGLE MEMBER ARM AND SHAFT ASSEMBLY	UNIT	4		
33	PEDESTRIAN SIGNAL ASSEMBLIES, TYPE W-1	UNIT	4		
34	PEDESTAL ASSEMBLIES, TYPE PW-1	UNIT	4		
35	PEDESTRIAN PUSH BUTTON ASSEMBLY, R10-3e	UNIT	8		
36	TRAFFIC SIGNAL CABLE, 2 CONDUCTOR	LF	1,230		
37	TRAFFIC SIGNAL CABLE, 5 CONDUCTOR	LF	1,670		
38	TRAFFIC SIGNAL CABLE, 10 CONDUCTOR	LF	1,230		
39	VIDEO DETECTION SYSTEM	UNIT	1		
40	TOPSOILING, 4" THICK	SY	295		
41	FERTILIZING & SEEDING, TYPE A-3	SY	295		
42	STRAW MULCHING	SY	295		

Written

Figures

BID CONTINGENCY: (To be used if and when directed by the County)

TWENTY FIVE THOUSAND DOLLARS

Written

\$25,000.00

Figures

TOTAL BASE BID ITEMS PLUS BID CONTINGENCY AMOUNT:

Written

Figures

NOTE: Bid Contingency may include one-half of one percent of contract amount set aside for local training if and when directed by the County.

Bidder's Name _____

CONSENT OF SURETY
TO ACCOMPANY PROPOSAL (BID)

_____ (hereinafter called Surety), organized and existing under the laws of the State of _____ duly authorized and qualified to transact business in the State of New Jersey, in consideration of the sum of One Dollar (\$1.00), lawful money of the United States of America, to it in hand paid, receipt whereof is hereby acknowledged, and in consideration, hereby certifies and agrees that if the contract for which the attached proposal is made be awarded to _____ (hereinafter called Contractor) for the performance of certain work and labor or the supplying of certain materials, or both, as more particularly set forth in said proposal and described for purposes of this instrument as a proposal for _____ to the COUNTY OF UNION and if Contractor shall enter into the contract, Surety will become bound as surety for its faithful performance, labor and material payment and will provide the Contractor with a performance, labor and material payment bond in the full amount of the contract price.

NOTE:
Expiration date
Needed if Annual
Surety

NAME OF INSURANCE COMPANY

ADDRESS: _____

ORIGINAL SIGNATURE
ATTORNEY-IN-FACT FOR INSURANCE CO.

NOTE: PROOF OF AUTHORITY OF OFFICERS OF SURETY COMPANY TO EXECUTE THIS DOCUMENT MUST BE SUBMITTED.

BIDDER SIGNATURE PAGE

THE BIDDER MUST READ THE FOLLOWING INSTRUCTIONS TO COMPLETE THIS PAGE:

1. If doing business under a **trade name, partnership or a sole proprietorship**, you must submit the bid under exact title of the trade name, partnership, or proprietorship, and the bid must be signed by either the **owner**, or a **partner** and **witnessed** by a **notary public**.
2. If a **Corporation**, the bid must be signed by the **President** or **Vice President** and **witnessed** by a **Corporate Secretary** (corporate title must be exact) and **affix corporate seal**. If a Corporate Secretary does not exist, President or Vice President's signature shall be witnessed by a Notary Public.
3. Other persons **authorized** by **corporate resolution** to execute agreements in its behalf may also sign the bid documents (pages). **Copy of a resolution must accompany the bid**.
4. The person who signs this bid form **must also** sign the **Non-Collusion Affidavit**.
5. You **cannot** witness your own signature.

NAME OF BIDDER

ADDRESS OF BIDDER

**ORIGINAL SIGNATURE
CORPORATE SECRETARY**

**PRINT NAME AND TITLE
CORPORATE SECRETARY**

TEL: _____
FAX: _____
E-Mail: _____

BY: _____
ORIGINAL SIGNATURE

Corporate Seal

PRINT OR TYPE NAME AND TITLE

WARNING: IF YOU FAIL TO FULLY, ACCURATELY, AND COMPLETELY SUPPLY THE INFORMATION REQUESTED ON THIS PAGE, YOUR BID MAY BE REJECTED.

Bidder's Name _____

STATEMENT OF OWNERSHIP DISCLOSURE

N.J.S.A. 52:25-24.2 (P.L. 1977, c.33, as amended by P.L. 2016, c.43)

This statement shall be completed, certified to, and included with all bid and proposal submissions. Failure to submit the required information is cause for automatic rejection of the bid or proposal.

Name of Organization: _____

Organization Address: _____

Part I Check the box that represents the type of business organization:

- Sole Proprietorship (skip Parts II and III, execute certification in Part IV)
- Non-Profit Corporation (skip Parts II and III, execute certification in Part IV)
- For-Profit Corporation (any type) Limited Liability Company (LLC)
- Partnership Limited Partnership Limited Liability Partnership (LLP)
- Other (be specific): _____

Part II

- The list below contains the names and addresses of all stockholders in the corporation who own 10 percent or more of its stock, of any class, or of all individual partners in the partnership who own a 10 percent or greater interest therein, or of all members in the limited liability company who own a 10 percent or greater interest therein, as the case may be. **(COMPLETE THE LIST BELOW IN THIS SECTION)**

OR

- No one stockholder in the corporation owns 10 percent or more of its stock, of any class, or no individual partner in the partnership owns a 10 percent or greater interest therein, or no member in the limited liability company owns a 10 percent or greater interest therein, as the case may be. **(SKIP TO PART IV)**

STATEMENT OF OWNERSHIP DISCLOSURE - CONTINUED

(Please attach additional sheets if more space is needed):

Name of Individual or Business Entity	Home Address (for Individuals) or Business Address

Part III DISCLOSURE OF 10% OR GREATER OWNERSHIP IN THE STOCKHOLDERS, PARTNERS OR LLC MEMBERS LISTED IN PART II

If a bidder has a direct or indirect parent entity which is publicly traded, and any person holds a 10 percent or greater beneficial interest in the publicly traded parent entity as of the last annual federal Security and Exchange Commission (SEC) or foreign equivalent filing, ownership disclosure can be met by providing links to the website(s) containing the last annual filing(s) with the federal Securities and Exchange Commission (or foreign equivalent) that contain the name and address of each person holding a 10% or greater beneficial interest in the publicly traded parent entity, along with the relevant page numbers of the filing(s) that contain the information on each such person. **Attach additional sheets if more space is needed.**

Website (URL) containing the last annual SEC (or foreign equivalent) filing	Page #'s

STATEMENT OF OWNERSHIP DISCLOSURE - CONTINUED

Please list the names and addresses of each stockholder, partner or member owning a 10 percent or greater interest in any corresponding corporation, partnership and/or limited liability company (LLC) listed in Part II **other than for any publicly traded parent entities referenced above**. The disclosure shall be continued until names and addresses of every noncorporate stockholder, and individual partner, and member exceeding the 10 percent ownership criteria established pursuant to N.J.S.A. 52:25-24.2 has been listed. **Attach additional sheets if more space is needed.**

Stockholder/Partner/Member and Corresponding Entity Listed in Part II	Home Address (for Individuals) or Business Address

Part IV Certification

I, being duly sworn upon my oath, hereby represent that the foregoing information and any attachments thereto to the best of my knowledge are true and complete. I acknowledge: that I am authorized to execute this certification on behalf of the bidder/proposer; that the **County of Union** is relying on the information contained herein and that I am under a continuing obligation from the date of this certification through the completion of any contracts with **County of Union** to notify the **County of Union** in writing of any changes to the information contained herein; that I am aware that it is a criminal offense to make a false statement or misrepresentation in this certification, and if I do so, I am subject to criminal prosecution under the law and that it will constitute a material breach of my agreement(s) with the, permitting the **County of Union** to declare any contract(s) resulting from this certification void and unenforceable.

Full Name (Print):		Title:	
Signature:		Date:	

Bidder's Name _____

SUBCONTRACTOR IDENTIFICATION STATEMENT

LIST OF SUBCONTRACTORS

This form is ONLY required for plumbing and gas fitting, steam and hot water heating and ventilating apparatus, steam power plants, electrical work, structural steel, ornamental iron work, and any other trades required to be identified by the specifications (including, but not limited, to satisfying any DPMC Classification requirements).

CHECK THIS BOX IF NONE OF THE ABOVE LISTED TRADES OR THOSE REQUIRED TO BE IDENTIFIED IN THE SPECIFICATIONS ARE TO BE USED TO PERFORM THE WORK

In compliance with N.J.S.A. 40A:11-16 and the bid specifications, the undersigned hereby lists the name or names of the following subcontractors:

Company Name: _____

Address: _____

Telephone: _____ Subcontract Amount: \$ _____

Specific Scope of Work Subcontracted: _____

License No. _____

Company Name: _____

Address: _____

Telephone: _____ Subcontract Amount: \$ _____

Specific Scope of Work Subcontracted: _____

License No. _____

Company Name: _____

Address: _____

Telephone: _____ Subcontract Amount: \$ _____

Specific Scope of Work Subcontracted: _____

License No. _____

IF MORE THAN THREE SUBCONTRACTORS, PLEASE COPY THIS SHEET AS NECESSARY AND ATTACH TO THE BID PACKAGE.

(Continued on following page)

Bidder's Name _____

SUBCONTRACTOR IDENTIFICATION CERTIFICATION

Note the law does not permit the listing of alternate subcontractors. However, multiple subcontractors for the same trade are permitted to be named provided the bidder meets the following requirements:

- Bidder identifies each subcontractor named for that category;
- Bidder states the scope of work, goods and services (the portion of the work) to be performed by each subcontractor; and
- Bidder provides the price quote provided by each subcontractor.

The bidder is advised that any change of subcontractor(s) from ones listed herein is subject to the County's approval. Change of subcontractor(s) will be approved only if made for good cause and not as a result of an arbitrary purpose.

The undersigned Bidder certifies and declares that the subcontractors listed above shall be used as subcontractors to complete certain portions of the work in this project as set forth in N.J.S.A. 40A: 11-16.

Witness

Date _____

NAME OF BIDDER

ADDRESS

By: _____
ORIGINAL SIGNATURE ONLY

PRINT NAME AND TITLE

Bidder's Name: _____

ACKNOWLEDGMENT OF ADDENDUM

COUNTY OF UNION

(Name of Construction /Public Works Project)

(Project or Bid Number)

Pursuant to N.J.S.A. 40A:11-23.1a., the undersigned bidder, hereby acknowledges receipt of the following notices, revisions, or addenda to the bid advertisement, specifications or bid documents. By indicating date of receipt, bidder acknowledges the submitted bid takes into account the provisions of the notice, revision or addendum. Note that the County of Union's record of notice to bidders shall take precedence and that failure to include provisions of changes in a bid proposal may be subject for rejection of the bid.

Local Unit Reference Number or Title of Addendum/Revision	How Received (mail, fax, pick-up, etc.)	Date Received

ACKNOWLEDGMENT BY BIDDER:

NAME OF BIDDER: _____

ORIGINAL SIGNATURE: _____

PRINTED NAME AND TITLE: _____

DATE: _____

CONTRACTOR BUSINESS REGISTRATION CERTIFICATE

New Mandatory Requirement - Effective 1/18/2010

The recently enacted **P.L. 2009, c.315**, requires that effective January 18, 2010; a contracting agency must receive proof of the bidder's business registration prior to the award of a contract. However, the proof must show that the bidder was in fact registered with the State of New Jersey Department of the Treasury, Division of Revenue and obtained the business registration prior to the receipt of bids.

If subcontractors are named on the bid, proof of the business registration for each subcontractor must be provided prior to the award of bid. Similarly to the bidder, the proof must show that each subcontractor was registered with the State of New Jersey Department of the Treasury, Division of Revenue and obtained the business registration prior to the receipt of bids.

Proof of business registration shall be

- A copy of a Business Registration Certificate issued by the Department of the Treasury, Division of Revenue; or
- A copy of the web version provided by the NJ Division of Revenue, or

Register online at www.nj.gov/treasury/revenue/taxreg.htm. Click the "online" link and then select "Register for Tax and Employer Purposes or call the Division at 609-292-1730.

Note: A NJ Certificate of Authority is not acceptable.

FAILURE to submit proof of registration of the bidder or any subcontractor named on the bid prior to the award of a contract shall be cause to reject the bids.

FAILURE of the bidder or any subcontractor named on the bid to be registered prior to the receipt of bids is cause for a **MANDATORY REJECTION** of bids. (A NON-WAIVABLE DEFECT). This covers construction work as well as non-construction bids.

IN ADDITION:

The contractor shall provide written notice to all **subcontractors and suppliers** not specifically named on the bid of the responsibility to register and submit proof of business registration to the contractor. The requirement of proof of business registration extends down through all levels (tiers) of the project.

Before final payment on the contract is made by the contracting agency, the contractor shall submit an accurate list and the proof of business registration of each subcontractor or supplier used in the fulfillment of the contract, or shall attest that no subcontractors were used.

For the term of the contract, the contractor and each of its affiliates and a subcontractor and each of its affiliates [N.J.S.A. 52:32-44(g)(3)] shall collect and remit to the Director, New Jersey Division of Taxation, the use tax due pursuant to the Sales and Use Tax Act on all sales of tangible personal property delivered into this State, regardless of whether the tangible personal property is intended for a contract with a contracting agency.

A business organization that fails to provide a copy of a business registration as required pursuant to section 1 of P.L.2001,c.134 (C.52:32-44 et al.) or subsection e. or f. of section 92 of P.L.1977,c.110 (C.5:12-92), or that provides false business registration information under the requirements of either of those sections, shall be liable for a penalty of \$25 for each day of violation, not to exceed \$50,000 for each business registration copy not properly provided under a contract with a contracting agency.

Bidder's Name _____

BUSINESS REGISTRATION
Mandatory Requirement

P.L. 2009, c.315, requires that effective January 18, 2010; a contracting agency must receive proof of the bidder's business registration prior to the award of a contract. However, the proof must show that the bidder was in fact registered with the State of New Jersey Department of the Treasury, Division of Revenue and obtained the business registration prior to the receipt of bids.

If subcontractors are named on the bid, proof of the business registration for each must be provided prior to the award of a contract. Similarly to the bidder, the proof must show that each subcontractor was registered with the State of New Jersey Department of the Treasury, Division of Revenue and obtained the business registration prior to the receipt of bids.

Proof of business registration shall be:

- A copy of a Business Registration Certificate issued by the Department of Treasury, Division of Revenue; or
- A copy of the web printed version provided by the NJ Division of Revenue

STATE OF NEW JERSEY BUSINESS REGISTRATION CERTIFICATE FOR STATE AGENCY AND CASINO SERVICE CONTRACTORS	
TAXPAYER NAME:	TRADE NAME:
TAX REGISTRATION TEST ACCOUNT	CLIENT REGISTRATION
TAXPAYER IDENTIFICATION:	SEQUENCE NUMBER:
970-007-382/000	0107510
ADDRESS:	ISSUANCE DATE:
847 ROEBLING AVE TRENTON NJ 08611	07/14/04
EFFECTIVE DATE:	
01/01/01	
FORM BRC(04/01)	

STATE OF NEW JERSEY BUSINESS REGISTRATION CERTIFICATE	
Taxpayer Name:	TAX REG TEST ACCOUNT
Trade Name:	
Address:	847 ROEBLING AVE TRENTON, NJ 08611
Certificate Number:	1093907
Date of issuance:	October 14, 2004
For Office Use Only:	
	20041014112623533

ATTACH BRC HERE

Bidder's Name _____

AFFIRMATIVE ACTION REQUIREMENT

REQUIRED AFFIRMATIVE ACTION EVIDENCE

General Requirements of P.L. 1975, c. 127: You are hereby put on notice that:

CONSTRUCTION CONTRACTS: The successful contractor must submit within three (3) days of the notice of intent to award or the signing of the contract the initial project manning report (A.A.201). This report should be submitted at the time the signed contract is returned to the County of Union. Attention: *Affirmative Action Officer*.

If the successful contract does not submit the initial project manning report (A.A.201) within the three (3) days from the time the signed contract is returned to the County of Union, the County of Union WILL declare the contractor non-responsive and award the contract to the next lowest responsible bidder.

NAME OF BIDDER

ORIGINAL SIGNATURE

PRINT OR TYPE NAME AND TITLE

DATE THIS FORM IS COMPLETED

EXPERIENCE STATEMENT

I hereby certify that my company has performed the following private or public work, which is relevant to this bid. I further certify that my company has never defaulted under any contract. Should you not sign this form due to prior defaults, please provide details on an attached sheet.

Witness

Date

NAME OF BIDDER

ADDRESS

By: _____
ORIGINAL SIGNATURE ONLY

PRINT NAME AND TITLE

YOU MAY ATTACH ADDITIONAL SHEETS, BUT YOU MUST SIGN AND WITNESS THIS SHEET.

Bidder's Name _____

NON-COLLUSION AFFIDAVIT

(N.J.S.A. 52:34-15)

STATE OF _____)
)
) SS: _____
COUNTY OF _____)

I _____, of the City of _____, in the County of _____, and the State of _____, of full age, being duly sworn according to law, on my oath depose and say that: I am _____ of the firm of _____, the bidder making the proposal for the above named project, and that I executed the said proposal for the above named project, and that I executed the said proposal with full authority to do so; that said bidder has not, directly or indirectly, entered into any agreement, participation in any collusion, or otherwise taken any action in restraint of free, competitive bidding in connection with the above named project; and that all statements contained in said proposal and in this Affidavit are true and correct, and made with full knowledge that the COUNTY OF UNION, NEW JERSEY relies upon the truth of the statements contained in said proposal and in the statements contained in the affidavit in awarding the contract for the said project.

I further warrant that no person or selling agency has been employed or retained to solicit or secure such contract upon an agreement or understanding for a commission, percentage, brokerage or contingent fee, except bona fide employees or bonafide established commercial or selling agencies maintained by _____ (N.J.S.A. 52:34-15).

NAME OF BIDDER

ORIGINAL SIGNATURE ONLY

NOTE: The person who signed the bidder signature page for the bidder should sign this form also.

Subscribed and sworn before me
this ____ day of _____, 200____.

Notary Public of the State of _____
My commission expires: _____

WARNING: IF YOU FAIL TO FULLY, ACCURATELY, AND COMPLETELY FILL OUT THIS AFFIDAVIT OF NON-COLLUSION, YOUR BID MAY BE REJECTED.

Contractor Registration Advisement
For Public Works Projects

A new law, known as "The Public Works Contractor Registration Act" (P.L. 1999, c.238), became effective April 11, 2000. Under the Act, no contractor/subcontractor will be permitted to bid on or engage in any contract for public work, as defined in Section 2 of P.L. 1963, c.150 (C:34:11-56.26), unless that contractor/subcontractor is registered with the New Jersey Department of Labor. The Act provides that upon registration with the Department, a public works contractor/subcontractor will be issued a certificate by the Department indicating compliance with the Act's requirements. The registration fee has been set at \$300.00 per year. Upon the effective date of the Act, public bodies will be expected to request production of such a certificate from those bidding on or engaging in public works projects.

It is important to note that the term "contractor," is defined in the, Act as, "a person, partnership, association, joint stock company, trust, corporation or other legal business entity or successor thereof who enters into a contract which is subject to the provision of the "New Jersey Prevailing Wage Act," P.L. 1963, c.150 (C.34:11-56.25, et seq.) for the construction, reconstruction, demolition, alteration, repair or maintenance of a public building regularly open to and used by the general public or a public institution, and includes any subcontractor or lower tier subcontractor as defined herein: except that, for the purposes of the act, no pumping station, treatment plant or other facility associated with utility and environmental construction, reconstruction, demolition, alteration, repair or maintenance shall be regarded as a public building regularly open to and used by the general public or a public institution."

Registration forms, copies of the Act, and other relevant information can be obtained by contacting:

Contractor Registration Unit
New Jersey Department of Labor
Division of Wage & Hour Compliance
PO Box 389
Trenton, New Jersey 08625-0389
Telephone: 609-292-9464
Fax: 609-633-8591
E-mail: contreg@dol.state.nj.us

Bidder's Name _____

AMERICANS WITH DISABILITIES ACT
EQUAL OPPORTUNITY FOR INDIVIDUALS WITH DISABILITIES

The contractor and the County of Union (hereafter "Owner") do hereby agree that the provisions of Title II of the Americans With Disabilities Act of 1990 (the "Act") (42 U.S.C.S12.101 et seq.), which prohibits discrimination on the basis of disability by public entities in all services, programs and activities provided or made available by public entities, and the rules and regulations promulgated pursuant thereto, are made a part of this contract. In providing any aid, benefit, or service on behalf of the Owner pursuant to this contract, the contractor agrees that the performance shall be in strict compliance with the Act. In the event the contractor, its agents, servants, employees, or subcontractors violate or are alleged to have violated the Act during the performance of this contract, the contractor shall defend the Owner in any action or administrative proceeding commenced pursuant to this Act. The contractor shall indemnify, protect, and save harmless the Owner, its agents, servants, and employees from and against any and all suits, claims, losses, demands, or damages of whatever kind or nature arising out of or claimed to arise out of the alleged violation. The contractor shall, at its own expense, appear, defend, and pay any and all charges for legal services and any and all costs and other expenses arising from such action or administrative proceeding or incurred in connection therewith. In any and all complaints brought pursuant to the Owner's grievance procedure, the contractor agrees to abide by any decision of the Owner which is rendered pursuant to said grievance procedure. If any action or administrative proceeding results in an award of damages against the Owner, or if the Owner incurs any expense to cure a violation of the ADA which has been brought pursuant to its grievance procedure, the contractor shall satisfy and discharge the same at its own expense.

The Owner shall, as soon as practicable after a claim has been made against it, give written notice thereof to the contractor along with full and complete particulars of the claim. If any action or administrative proceeding is brought against the Owner or any of its agents, servants, and employees, the Owner shall expeditiously forward or have forwarded to the contractor every demand, complaint, notice, summons, pleading, or process received by the Owner or its representatives.

It is expressly agreed and understood that any approval by the Owner of the services provided by the contractor pursuant to this contract will not relieve the contractor of the obligation to comply with the Act and to defend, indemnify, protect, and save harmless the Owner pursuant to this paragraph.

It is further agreed and understood that the Owner assumes no obligation to indemnify or save harmless the contractor, its agents, servants, employees and subcontractors for any claim which may arise out of their performance of this Agreement. Furthermore, the contractor expressly understands and agrees that the provisions of this indemnification clause shall in no way limit the contractor's obligations assumed in this Agreement, nor shall they be construed to relieve the contractor from any liability, nor preclude the Owner from taking any other actions available to it under any other provisions of this Agreement or otherwise at law.

Name _____ (Please print or type)

Signature _____ Date _____

Bidder's Name _____

STATEMENT OF BIDDER'S QUALIFICATIONS

All questions must be answered and the data given must be clear and comprehensive. This statement must be notarized. Questions may be answered on separate attached sheets. The Bidder may submit any additional information it desires.

1. _____
(Name of Bidder)

2. _____
(Permanent Main Office Address)

3. _____
(When Organized)

4. _____
(If a Corporation, where incorporated)

5. Number of years your organization has been engaged in construction or contracting business under present firm or trade name? _____

6. How many years of experience in construction work has your organization had (a) as a general contractor? And/or (b) As a subcontractor? _____

7. Contracts on hand: (Attach a list or table showing gross amounts of each Contract and the appropriate dates of completion) _____

8. General character of work performed by you. _____

9. Have you ever failed to complete any work awarded to you? _____

10. Have you ever defaulted on a Contract? _____ If so, complete details, including where and why?

Bidder's Name _____

STATEMENT OF BIDDER'S QUALIFICATIONS - (continued)

11. Has any officer or partner of your organization ever failed to complete a construction contract handled in its own name? If so, state name of individual, name of owner, location and type of project, and reason for the failure to complete. _____

12. List your major equipment available for this Contract.

13. Experience in the construction work similar in importance to this Project.

14. Have you had any material adverse changes from the trades as listed in NJ Notice of Classification within last five (5) years? _____. If so, list prior classification.

15. Background and experience of the principal members of your organization, including the officers.

Individual's Name	Present Position or Office	Yrs. of Construction Experience	Magnitude & Type of Work	In What Capacity

16. Bank Reference. (Name, Address, Phone, Representative) _____
17. Will you, upon request, fill out a detailed financial statement and furnish any other information that may be required by the proper agency? _____
18. The undersigned, hereby authorizes and requests any person, firm or corporation to furnish any information requested by the proper agency in verification of the responses comprising this Statement of Bidder's Qualifications.
17. Bidder's telephone number, fax number and e-mail address (if applicable).
- Phone _____
- Fax _____
- E-mail _____
- Mobile _____

Dated at _____ this _____ day of __, 20__.

BIDDER (Signature)

BIDDER (Print Name)

Subscribed and sworn to before me
this _____ day of _____, 20__.

(Seal) Notary Public of New Jersey/
Specify Other State
My Commission Expires _____, 20__.

**NOTE: FAILURE TO COMPLETE AND SUBMIT THIS DOCUMENT WITH
YOUR PROPOSAL MAY RESULT IN A REJECTION OF YOUR BID.**

Bidder's Name _____

CONTRACTOR PERFORMANCE RECORD

List all contracts completed by you below or provide separate form.

Name of Owner	Name & Location of Project: Type Of Work	Prime or Sub-Cont.	Engineer or Architect in Charge for Owner	Contract Price (Omit Cost)	Date Completed	Was Time* Extension Necessary	Were Any Penalties Imposed	Were Liens* Claims or Stop Notice Filed

* If answer is YES, provide explanation of details in connection with non-completion of contracts, time extensions, penalties imposed, labor troubles, liens, claims and notices filed against contracts listed in preceding item "Performance Record" on an attached sheet.

NOTE: FAILURE TO COMPLETE AND SUBMIT THIS DOCUMENT WITH YOUR PROPOSAL MAY RESULT IN A REJECTION OF YOUR BID.

Bidder's Name _____

CONTRACTOR PERFORMANCE RECORD
CERTIFICATION

The information above is true and complete to the best of my knowledge and belief.

(Name of Organization)

(Signature)

(Title)

Subscribed and sworn to before me

this _____ day of _____, 20__.

(Seal) Notary Public of New Jersey/
Specify Other State

My Commission Expires _____, 20__.

PRIOR NEGATIVE EXPERIENCE QUESTIONNAIRE

(N.J.S.A. 40A:11-4)

1. Within the past ten (10) years, have you been found, through either court adjudication, arbitration, mediation, or other contractually stipulated alternate dispute resolution mechanism, to have: failed to provide or perform goods or services; or failed to complete a contract in a timely manner; or otherwise performed unsatisfactorily under a prior contract with a public entity?

_____ yes _____ no If yes, please provide full, detailed explanation.

2. Within the past ten (10) years, have you defaulted on a contract, thereby requiring a public entity to utilize the services of another contractor to provide the goods or perform the services or to correct or complete the contract?

_____ yes _____ no If yes, please provide full, detailed explanation.

3. Within the past ten (10) years, have you defaulted on a contract, thereby requiring a public entity to look to your surety for completion of the contract or tender of the costs of completion?

_____ yes _____ no If yes, please provide full, detailed explanation.

4. Within the past ten (10) years, have you been debarred or suspended from contracting with any of the agencies or department of the executive branch of the State of New Jersey at the time of the contract award, where the action was based on failure to perform a contract for goods or services with a public entity?

_____ yes _____ no If yes, please provide full, detailed explanation.

Bidder's Name _____

PRIOR NEGATIVE EXPERIENCE CERTIFICATION

I hereby certify that the above statements are true and accurate as of this _____
day of _____, 20__.

Name of Contractor

By _____
(Signature of Authorized Representative)

Subscribed and sworn to before me
this _____ day of _____, 20__.

(Seal) Notary Public of New Jersey/
Specify Other State

My Commission Expires _____, 20__.

NOTE: FAILURE TO COMPLETE AND SUBMIT THIS DOCUMENT WITH YOUR PROPOSAL MAY RESULT IN A REJECTION OF YOUR BID.

Bidder's Name _____

TO BE COMPLETED ONLY WHEN FINAL PAYMENT IS REQUESTED

CONTRACTOR'S CERTIFICATION OF COMPLIANCE - NEW JERSEY PREVAILING WAGE ACT

TO: County of Union
Division of Engineering
2325 South Avenue
Scotch Plains, New Jersey 07076

CONTRACT: _____

PROJECT: _____

In accordance with the requirements of the New Jersey Prevailing Wage Act, N.J.S.A. 34:11-56 et al *, the undersigned contractor on the public work being performed for:

COUNTY OF UNION

hereby certifies that he/she has complied with the contract requirements regarding the payment of the minimum prevailing wages established under "The New Jersey Prevailing Wage Act" N.J.S.A. 34:11-56 et al.

CONTRACTOR: _____
ADDRESS: _____

BY: _____
ORIGINAL SIGNATURE ONLY

STATE OF NEW JERSEY
COUNTY OF _____

Being by me duly sworn according to law, on his oath deposes and says that _____ is _____ of _____ the above named contractor, and that the facts set forth in the above statement are true.

Subscribed and sworn before me
this ____ day of _____, 200__.

Notary Public: _____
My Commission Expires: _____

* N.J.S.A. 34:11-56.33 requires the contractor and subcontractor to file written statements with the public body in form satisfactory to the Commissioner certifying to the amounts then due and owing from such contractor and subcontractor filing such statement to any and all workmen for wages due on account of the public work, setting forth therein the names of the persons whose wages are unpaid and the amount due to each respectively. Union County will withhold the amount so deducted for the benefit of the workmen whose wages are unpaid as shown by the verified statement filed, and will pay directly to any workman the amount shown by such statement to be due to him for such wages. Such payment shall thereby discharge the obligation of the contractor to the person receiving such payment to the extent of the amount thereof.

Bidder's Name _____

UNCOMPLETED CONTRACTS AFFIDAVIT
(To be Submitted with DPMC Form 701)

PURSUANT TO N.J.A.C. 17:19-2.13, BIDDER DECLARES THE FOLLOWING WITH RESPECT TO ITS UNCOMPLETED CONTRACTS, ON ALL WORK, FROM WHATEVER SOURCE (PUBLIC AND PRIVATE), BOTH IN NEW JERSEY AND FROM OTHER GOVERNMENTAL JURISDICTIONS

ENTITY	PROJECT TITLE	ORIGINAL CONTRACT AMOUNT	UNCOMPLETED AMOUNT AS OF BID OPENING DATE	NAME AND TELEPHONE NUMBER OF PARTY TO BE CONTACTED FROM ENTITY FOR VERIFICATION

TOTAL AMOUNT OF UNCOMPLETED CONTRACTS \$ _____

Sworn and Subscribed to Before me

This _____ day of _____, 20____

Notary Public

BIDDER:

(Signature)

(Print Name)

NOTE: FAILURE TO COMPLETE AND SUBMIT THIS DOCUMENT WITH YOUR PROPOSAL MAY RESULT IN A REJECTION OF YOUR BID.

Bidder's Name _____

CERTIFICATE OF INSURANCE STATEMENT

The Bidder fully understands the County of Union insurance requirements as stated in the Instructions to Bidders as well as the Owner/Contractor Agreement and agrees to provide all insurance required by these documents prior to the issuance of the Notice to Proceed.

BIDDER (Signature)

BIDDER (Print Name)

NOTE: FAILURE TO COMPLETE AND SUBMIT THIS DOCUMENT WITH YOUR PROPOSAL MAY RESULT IN A REJECTION OF YOUR BID.

Bidder's Name _____

COLLECTION OF USE TAX ON SALES TO LOCAL GOVERNMENTS STATEMENT

The Bidder fully understands the requirements of the use tax on sales to local governments as stated in the General Conditions to the Contract for Construction and the Instructions to Bidders, and agrees at all times to comply with the "Contractor Use Tax Collection Legislation", as defined therein, and the terms relating thereto contained in the Contract Documents.

BIDDER (Signature)

BIDDER (Print Name)

NOTE: FAILURE TO COMPLETE AND SUBMIT THIS DOCUMENT WITH YOUR PROPOSAL MAY RESULT IN A REJECTION OF YOUR BID.

Bidder's Name _____

TIME OF COMPLETION

The undersigned proposed that if awarded the Contract, the scope of work will be started within ten (10) calendar days and will be substantially completed within one hundred fifty (150) calendar days from the date of the notice to proceed.

I, _____ of _____
NAME (Print or type) COMPANY

Agree to complete work in the time frame specified _____
SIGNATURE

SITE VISIT – GENERAL CONTRACTOR

I, _____ of _____
NAME (Print or type) COMPANY

Visited the site of the work on _____
SIGNATURE

COUNTY OF UNION NEW JERSEY
Division of Purchasing
DISCLOSURE OF INVESTMENT ACTIVITIES IN IRAN

Solicitation Number: _____ Bidder/Offeror: _____

Pursuant to Public law 2012, c. 25, any person or entity that submits a bid or proposal or otherwise proposes to enter into or renew a contract must complete the certification below to attest, under penalty of perjury, that the person or entity, or one of the person or entity's parents, subsidiaries, or affiliates, is not identified on a list created and maintained by the Department of the Treasury as a person or entity engaging in investment activities in Iran. If the Director finds a person or entity to be in violation of the principles which are the subject of the law, s/he shall take action as may be appropriate and provided by law, rule or contract, including but not limited to, imposing sanctions, seeking compliance, recovering damages, declaring the party in default and seeking debarment or suspension of the person or entity.

I certify, pursuant to Public Law 2012, c. 25, that the person or entity listed above for which I am authorized to bid/renew:

is not providing goods or services of \$20,000,000 or more in the energy sector of Iran, including a person or entity that provides oil or liquefied natural gas tankers, or products used to construct or maintain pipe lines used to transport oil or liquefied natural gas, for the energy sector of Iran,
AND

is not a financial institution that extends \$20,000,000 or more in credit to another person or entity, for 45 days or more, if that person or entity will use the credit to provide goods or services in the energy sector in Iran.

In the event that a person or entity is unable to make the above certification because it or one of its parents, subsidiaries, or affiliates has engaged in the above-referenced activities, a detailed, accurate and precise description of the activities must be provided in part 2 below to the Division of Purchase under penalty of perjury. Failure to provide such will result in the proposal being rendered as non-responsive and appropriate penalties, fines and/or sanctions will be assessed as provided by law.

PART 2: PLEASE PROVIDE FURTHER INFORMATION RELATED TO INVESTMENT ACTIVITIES IN IRAN. You must provide, accurate and precise description of the activities of the bidding person/entity, or one of its parents, subsidiaries or affiliates, engaging in the investment activities in Iran outlined above by completing the boxes below.

Name _____ Relationship to Bidder/Offeror _____

Description of Activities _____

Duration of Engagement _____ Anticipated Cessation Date _____

Bidder/Offeror Contact Name _____ Contact Phone Number _____

Certification: I, being duly sworn upon my oath, hereby represent and state that the foregoing information and any attachments thereto to the best of my knowledge are true and complete. I attest that I am authorized to execute this certification on behalf of the above referenced person or entity. I acknowledge that Union County is relying on the information contained herein and hereby acknowledge that I am under a continuing obligation from the date of this certification through the completion of any contracts with the County to notify the County in writing of any changes to the answers of information contained herein. I acknowledge that I am aware that it is a criminal offense to make a false statement or misrepresentation in this certification, and if I do so, I recognize that I am subject to criminal prosecution under the law and that it will also constitute a material breach of my agreement(s) with Union County, New Jersey and that the County at its option may declare any contract(s) resulting from this certification void and unenforceable.

Full Name (Print) _____ Signature _____

Title _____ Date _____

STANDARD SPECIFICATIONS

The Standard Specifications for Road and Bridge Construction of New Jersey Department of Transportation, 2007 Edition; is added to and/or amended elsewhere herein by the Notice to Contractors (Advertisement), Proposal, Information for Bidders, General Conditions, Special Provisions, Project Plans, and Supplementary Specifications; shall, insofar as technical requirements are involved, govern in the execution of this project.

Such Standard Specifications are made a part of these Specifications by this reference and will not be repeated herein. It is the responsibility of prospective bidders to familiarize themselves with these Standard Specifications, copies of which may be examined at the office of the Engineer and may be obtained, upon payment of the cost thereof, from:

Department of Transportation
State of New Jersey
1035 Parkway Avenue
Trenton, New Jersey 08625

The Notice to Bidders (Advertisement), Proposal, General Conditions, Instructions to Bidders, Special Provisions, Project Plans and/or Technical Specifications shall govern and prevail in the case of conflict between them and the Standard Specifications.

In these Standard Specifications the words "COMMISSIONER" or "DEPARTMENT" shall refer to and mean the person, persons, body, board or agent legally empowered to enter into contracts and otherwise legally act for the Owner. The words "RESIDENT ENGINEER (RE)", "ENGINEER" or "STATE" shall refer to and mean the professional engineering representative of the Owner as hereinbefore defined and the word "INSPECTOR" shall mean the authorized project representative of the Engineer with the authority as hereinbefore defined. The word "LABORATORY" shall mean and refer to the Engineer who may, at his discretion, and with the consent of the Owner, employ qualified technical personnel or testing laboratories to assist him in fulfilling the duties normally assigned to the "LABORATORY" in these Standard Specifications.

When reference is made herein to the bulletins, standards, specifications, publications or requirements of the Manual on Uniform Traffic Control Devices (MUTCD), Institute of Traffic Engineers (ITE), Federal Highway Administration (FHWA), American Association of State Highway Officials (AASHTO), the American Concrete Institute (ACI), the American Society of Civil Engineers (ASCE) or similar national or regional societies, associations, institutes or organizations; the requirements of the bulletins, specifications, publications or requirements referred to shall be considered a part of these Specifications by such reference and shall not be repeated herein but shall have the same import and be as binding as if herein set forth in full.



STATE OF NEW JERSEY
Department of Labor and Workforce Development
Division of Wage and Hour Compliance - Public Contracts Section
PO Box 389
Trenton, NJ 08625-0389

PREVAILING WAGE RATE DETERMINATION

The New Jersey Prevailing Wage Act (N.J.S.A. 34:11-56.25 et seq.) requires that the Department of Labor and Workforce Development establish and enforce a prevailing wage level for workers engaged in public works in order to safeguard their efficiency and general well being and to protect them as well as their employers from the effects of serious and unfair competition.

Prevailing wage rates are wage and fringe benefit rates based on the collective bargaining agreements established for a particular craft or trade in the locality in which the public work is performed. In New Jersey, these rates vary by county and by the type of work performed.

Applicable prevailing wage rates are those wages and fringe benefits in effect on the date the contract is awarded. All pre-determined rate increases listed at the time the contract is awarded must also be paid, beginning on the dates specified. Rates that have expired will remain in effect until new rates are posted.

Prevailing Wage Rate

The prevailing wage rate for each craft will list the effective date of the rate and the following information:

W = Wage Rate per Hour **B** = Fringe Benefit Rate per Hour* **T** = Total Rate per Hour

* Fringe benefits are an integral part of the prevailing wage rate. Employers not providing such benefits must pay the fringe benefit amount directly to the employee each payday. Employers providing benefits worth less than the fringe benefit amount must pay the balance directly to the employee each payday.

Unless otherwise stated in the Prevailing Wage Rate Determination, the fringe benefit rate for overtime hours remains at the straight time rate.

When the Overtime Notes in the Prevailing Wage Rate Determination state that the overtime rates are "inclusive of benefits," the benefit rate is increased by the same factor as the wage rate (i.e. multiplied by 1.5 for time and one-half, multiplied by 2 for double time, etc.).

Apprentice Rate Schedule

An "apprentice" is an individual who is registered with the United States Department of Labor - Office of Apprenticeship and enrolled in a certified apprenticeship program during the period in which they are working on the public works project.

The apprentice wage rate is a percentage of the journeyman wage rate, unless otherwise indicated. The apprentice benefit rate is the full journeyman benefit rate, unless otherwise indicated.

If there is no apprentice rate schedule listed, the individual must be paid at least the journeyman rate even if that individual is in a certified apprentice program for that trade.

If there is no ratio of apprentices to journeymen listed for a particular craft, then the ratio shall be one (1) apprentice to every four (4) journeymen.

Comments/Notes

For each craft listed there will be comments/notes that cover the definition of the regular workday, shift differentials, overtime, recognized holidays, and any other relevant information.

Public Works Contractor Registration

The Public Works Contractor Registration Act (N.J.S.A. 34:11-56.48, et seq.) requires that **all** contractors, subcontractors, or lower tier subcontractors who are working on or who bid on public works projects register with the Department of Labor and Workforce Development. Applications are available at www.nj.gov/labor (click on Wage & Hour and then go to Registration & Permits).

Pursuant to N.J.S.A. 34:11-56.51:

No contractor shall bid on any contract for public work as defined in section 2 of P.L.1963, c. 150 (C.34:11-56.26) unless the contractor is registered pursuant to this act. No contractor shall list a subcontractor in a bid proposal for the contract unless the subcontractor is registered pursuant to P.L.1999, c.238 (C.34:11-56.48 et seq.) at the time the bid is made. No contractor or subcontractor, including a subcontractor not listed in the bid proposal, shall engage in the performance of any public work subject to the contract, unless the contractor or subcontractor is registered pursuant to that act.

Snow Plowing

Snow plowing contracts are not subject to the New Jersey Prevailing Wage Act or the Public Works Contractor Registration Act.

**NEW JERSEY DEPARTMENT OF LABOR AND WORKFORCE DEVELOPMENT
PREVAILING WAGE RATE DETERMINATION**

County - UNION

Craft: Air Conditioning & Refrigeration - Service and Repair

PREVAILING WAGE RATE

	03/01/17
Journeyman (Mechanic)	W37.48 B22.91 T60.39

Craft: Air Conditioning & Refrigeration - Service and Repair

APPRENTICE RATE SCHEDULE

INTERVAL	PERIOD AND RATES									
	Mo. 1-3	Mo. 4-12	2nd Year	3rd Year	4th Year	5th Year		Wage = %	of Jnymn	Wage
As Shown										
Wage and Bene	50%	55%	60%	65%	75%	85%		Bene = %	of Jnymn	Bene

Ratio of Apprentices to Journeymen - 1:4

APPRENTICE RATE SCHEDULE FOR THOSE APPRENTICES ENTERING PROGRAM AFTER 3-1-13:

INTERVAL	PERIOD AND RATES							
As Shown	1st Year	2nd Year	3rd Year	4th Year	5th Year		Wage =% of Jnymn Wage	
Wage and Benefit	40%	50%	60%	70%	80%		Bene. =% of Jnymn Wage	

Craft: Air Conditioning & Refrigeration - Service and Repair

COMMENTS/NOTES

THESE RATES MAY BE USED FOR THE FOLLOWING:

- Service/Repair/Maintenance Work to EXISTING facilities.
- Replacement or Installation of air conditioning and refrigeration equipment when the combined tonnage does not exceed 15 tons for refrigeration, or 25 tons for air conditioning.
- Replacement or Installation of "packaged" or "unitary" rooftop-type units when the combined tonnage of the units does not exceed 75 tons.

NOTE: These rates may NOT be used for any work in new construction (including work on new additions).

The regular workday shall consist of 8 hours, starting between 6:00 AM and 10:00 AM, Monday through Friday.

SHIFT DIFFERENTIALS:

- The second and third shifts shall be paid an additional 15% of the hourly rate.
- All shifts must run for a minimum of 5 consecutive days.

OVERTIME:

Hours worked in excess of 8 per day or before or after the regular workday, that are not shift work, and all hours on Saturday shall be paid at time and one-half the hourly rate, inclusive of benefits. All hours on Sunday and holidays shall be paid at double the hourly rate, inclusive of benefits.

RECOGNIZED HOLIDAYS: New Year's Day, Presidents' Day, Memorial Day, July 4th, Labor Day, Veterans' Day, Thanksgiving Day, Christmas Day.

**NEW JERSEY DEPARTMENT OF LABOR AND WORKFORCE DEVELOPMENT
PREVAILING WAGE RATE DETERMINATION**

County - UNION

Craft: Boilermaker PREVAILING WAGE RATE

	01/01/17
Foreman	W48.70 B41.32 T90.02
General Foreman	W50.70 B42.30 T93.00
Journeyman	W43.70 B39.72 T83.42

Craft: Boilermaker APPRENTICE RATE SCHEDULE

INTERVAL	PERIOD AND RATES									
	65%	70%	75%	80%	85%	90%	95%			
1000 Hours										
Benefit =	33.58	34.50	35.38	36.24	37.12	37.49	38.85			

Ratio of Apprentices to Journeymen - *

* 1 apprentice will be allowed for the first 5 journeymen, 1 apprentice for the next 10 journeymen and 1 apprentice for each succeeding 20 journeymen up to a maximum of 5 apprentices per contractor on any one job.

Craft: Boilermaker COMMENTS/NOTES

HIGH WORK: All apprentices working on the erection, repair, or dismantling of smoke stacks, standpipes, or water towers shall be paid the Journeyman rate.

The regular workday shall consist of 8 hours, between 8:00 AM and 4:30 PM.

SHIFT DIFFERENTIALS:

- The second shift shall work 7½ hours and receive 8 hours pay, at a rate equal to the regular hourly rate plus 10%.
- The third shift shall work 7 hours and receive 8 hours pay, at a rate equal to the regular hourly rate plus 20%.
- For "Municipal Water Works" projects only, the following shall apply: Two, four day, 10 hour shifts may be worked at straight time Monday through Thursday. The day shift shall work four days, at 10 hours, for 10 hours pay. The second shift shall work four days, at nine and a half hours, for 10 hours pay, plus 10% the hourly rate for new work and .25 cents on repair work. Friday may be used as a make-up day at straight time, due to weather conditions, holiday or any other circumstances beyond the employer's control.

OVERTIME:

- Hours in excess of 8 per day, Monday through Friday, and all hours on Saturdays shall be paid at time and one-half the hourly rate. All hours on Sundays and holidays (except Labor Day) shall be paid at double the hourly rate. All hours on Labor Day shall be paid at four times the hourly rate.
- If any other craft employed by the same contractor, or a subcontractor thereof, receives double time in lieu of time and one-half, then the Boilermaker shall receive double time in lieu of time and one-half.
- For "Municipal Water Works" projects only, the following shall apply: Four 10 hour days may be worked Monday through Thursday at straight time. Friday may be used as a make-up day for a day lost to inclement weather, holiday or other conditions beyond the control of the employer. Overtime shall be paid for any hours that exceed 10 hours per day or 40 hours per week.

**NEW JERSEY DEPARTMENT OF LABOR AND WORKFORCE DEVELOPMENT
PREVAILING WAGE RATE DETERMINATION**

County - UNION

RECOGNIZED HOLIDAYS: New Year's Day, Washington's Birthday, Memorial Day, July 4th, Labor Day, Presidential Election Day, Veterans' Day, Thanksgiving Day, Christmas Day. Sunday holidays observed the following Monday.

**NEW JERSEY DEPARTMENT OF LABOR AND WORKFORCE DEVELOPMENT
PREVAILING WAGE RATE DETERMINATION**

County - UNION

Craft: Boilermaker - Minor Repairs

PREVAILING WAGE RATE

	01/01/17
Foreman	W32.54 B16.17 T48.71
General Foreman	W33.04 B16.17 T49.21
Mechanic	W31.04 B16.17 T47.21

Craft: Boilermaker - Minor Repairs

COMMENTS/NOTES

NOTE: These rates apply to MINOR REPAIR WORK ONLY (repair work in the field for which the contract amount does not exceed \$125,000.00).

OVERTIME:

Hours in excess of 8 per day, Monday through Friday, and all hours on Saturdays shall be paid at time and one-half the hourly rate. All hours on Sundays and holidays (except Labor Day) shall be paid at double the hourly rate. All hours on Labor Day shall be paid at four times the hourly rate.

RECOGNIZED HOLIDAYS: New Year's Day, Washington's Birthday, Good Friday, Memorial Day, July 4th, Labor Day, Presidential Election Day, Thanksgiving Day, day after Thanksgiving, Christmas Day. Saturday holidays observed the preceding Friday, Sunday holidays observed the following Monday.

**NEW JERSEY DEPARTMENT OF LABOR AND WORKFORCE DEVELOPMENT
PREVAILING WAGE RATE DETERMINATION**

County - UNION

Craft: Bricklayer, Stone Mason

PREVAILING WAGE RATE

	11/01/16	05/01/17	05/01/18
Deputy Foreman	W43.00 B30.91 T73.91	W0.00 B0.00 T76.04	W0.00 B0.00 T78.23
Foreman	W46.00 B30.91 T76.91	W0.00 B0.00 T79.04	W0.00 B0.00 T81.23
Journeyman	W40.00 B30.91 T70.91	W0.00 B0.00 T73.04	W0.00 B0.00 T75.23

Craft: Bricklayer, Stone Mason

APPRENTICE RATE SCHEDULE

INTERVAL	PERIOD AND RATES									
	40%	50%	55%	60%	65%	70%	75%	80%		
6 Months										
Benefits	3.72	4.65	5.12	5.58	20.48	21.83	23.18	24.52		

Ratio of Apprentices to Journeymen - 1:5

Craft: Bricklayer, Stone Mason

COMMENTS/NOTES

The regular workday shall consist of 8 hours, between 6:00 AM and 4:30 PM.

SHIFT DIFFERENTIALS:

- When a 2 shift schedule (including a day shift) is established, the first, or day shift, shall be established on an 8 hour basis. The second shift shall be established on an 8 hour basis, and receive the regular rate plus 10%, inclusive of benefits.
- When a three shift schedule is established, the first shift shall be established on an 8 hour basis, the second shift on a 7.5 hour basis, and the third shift on a 7 hour basis. The first shift shall receive the regular hourly rate, the second shift shall receive the regular rate plus 10%, inclusive of benefits, and the third shift shall receive the regular rate plus 15%, inclusive of benefits.
- When there is no day shift, and a second or third shift is established, it shall be established on an 8 hour basis. The second shift shall receive the regular rate plus 10%, inclusive of benefits, and the third shift shall receive the regular rate plus 15%, inclusive of benefits.
- When an irregular shift must be established, this shift shall receive the regular rate plus 10%, inclusive of benefits.

OVERTIME:

- The first 2 hours in excess of 8 per day, or before or after the regular workday that are not shift work, Monday through Friday, shall be paid at time and one-half the regular rate, inclusive of benefits. Any additional overtime shall be paid at double the regular rate, inclusive of benefits. The first 10 hours on Saturday shall be paid at time and one-half the regular rate, inclusive of benefits. Any additional overtime shall be paid at double the regular rate, inclusive of benefits. All hours on Sundays and holidays shall be paid at double the regular rate, inclusive of benefits.
- Saturday may be used as a make-up day for hours lost to inclement weather.
- When Bricklayers/Stone Masons work on Saturday with Laborers, and no other crafts are working on the project for the day, benefits may be paid at straight time. If other crafts are present, the applicable overtime rate for benefits shall be paid.

**NEW JERSEY DEPARTMENT OF LABOR AND WORKFORCE DEVELOPMENT
PREVAILING WAGE RATE DETERMINATION**

County - UNION

RECOGNIZED HOLIDAYS: New Year's Day, Presidents' Day, Memorial Day, July 4th, Labor Day, Presidential Election Day, Veterans' Day, Thanksgiving Day, Christmas Day. Sunday holidays will be observed the following Monday.

**NEW JERSEY DEPARTMENT OF LABOR AND WORKFORCE DEVELOPMENT
PREVAILING WAGE RATE DETERMINATION**

County - UNION

Craft: Carpenter PREVAILING WAGE RATE

	11/01/16	05/01/17	11/01/17	05/01/18	11/01/18
Foreman	W53.42	W0.00	W0.00	W0.00	W0.00
	B30.44	B0.00	B0.00	B0.00	B0.00
	T83.86	T85.04	T86.04	T87.29	T88.54
Journeyman	W46.45	W0.00	W0.00	W0.00	W0.00
	B26.48	B0.00	B0.00	B0.00	B0.00
	T72.93	T74.23	T75.23	T76.48	T77.73

Craft: Carpenter APPRENTICE RATE SCHEDULE

INTERVAL	PERIOD AND RATES									
	Yearly	40%	55%	65%	80%	90%				
Benefit	57% of	Appren	tice	Wage	for all	intervals				

Ratio of Apprentices to Journeymen - 1:3

Craft: Carpenter COMMENTS/NOTES

FOREMAN REQUIREMENTS:

- When there are 2 or more Carpenters on a job, 1 shall be designated as a Foreman.
- When there are 21 or more Carpenters on a job, 2 shall be designated as Foremen.

The regular workday shall consist of 8 hours, starting between 7:00 AM and 9:00 AM.

SHIFT DIFFERENTIALS:

- When a 2 shift schedule (including a day shift) is established, the day shift shall be established on an 8 hour basis. The second shift shall be established on an 8 hour basis, and receive the regular rate plus 15%, inclusive of benefits.
- When a three shift schedule is established, the first shift shall be established on an 8 hour basis, the second shift on a 7.5 hour basis, and the third shift on a 7 hour basis. The first shift shall receive the regular hourly rate, the second shift shall receive the regular rate plus 15% and the third shift shall receive the regular rate plus 20%, inclusive of benefits.
- When there is no day shift, and a second or third shift is established, it shall be established on an 8 hour basis. The second shift shall receive the regular rate plus 15% and the third shift shall receive the regular rate plus 20%, inclusive of benefits.

OVERTIME:

- All hours in excess of 8 per day, or before or after an established shift that are not shift work, and all hours on Saturdays shall be paid at time and one-half the hourly rate, inclusive of benefits. All hours on Sundays and holidays shall be paid at double the hourly rate, inclusive of benefits.
- Four 10-hour days may be worked, Monday to Thursday, at straight time. Friday may be used as a make-up day for a day lost due to inclement weather. If Friday is not a make-up day, all hours on Friday shall be paid at time and one-half the hourly rate, inclusive of benefits.

RECOGNIZED HOLIDAYS: New Year's Day, Presidents' Day, Memorial Day, July 4th, Labor Day, Presidential Election Day, Veterans' Day, Thanksgiving Day, Christmas Day. Sunday holidays observed the following Monday.

**NEW JERSEY DEPARTMENT OF LABOR AND WORKFORCE DEVELOPMENT
PREVAILING WAGE RATE DETERMINATION**

County - UNION

Craft: Carpenter - Resilient Flooring

PREVAILING WAGE RATE

	11/01/16	05/01/17	11/01/17	05/01/18	11/01/18
Foreman	W53.42	W0.00	W0.00	W0.00	W0.00
	B30.44	B0.00	B0.00	B0.00	B0.00
	T83.86	T85.04	T86.04	T87.29	T88.54
Journeyman	W46.45	W0.00	W0.00	W0.00	W0.00
	B26.48	B0.00	B0.00	B0.00	B0.00
	T72.93	T74.23	T75.23	T76.48	T77.73

Craft: Carpenter - Resilient Flooring

APPRENTICE RATE SCHEDULE

INTERVAL	PERIOD AND RATES									
	Yearly	40%	55%	65%	80%	90%				
Benefit	57%	of	Appren	tice	Wage	for all	intervals			
					Rate					

Ratio of Apprentices to Journeymen - *

* 1 apprentice shall be allowed to every 2 journeymen or major fraction thereof. No more than 3 apprentices on any one job or project.

Craft: Carpenter - Resilient Flooring

COMMENTS/NOTES

FOREMAN REQUIREMENTS:

- On any job where there are 4 or more Carpenters of Resilient Flooring, 1 must be designated a Foreman.

FOR SYNTHETIC TURF INSTALLATION ONLY:

- The rate shall be 90% of the wage and benefit rate.

The regular workday consists of 8 hours, starting between 6:00 AM and 9:00 AM.

SHIFT DIFFERENTIALS:

- When a 2 shift schedule (including a day shift) is established, the day shift, shall be established on an 8 hour basis. The second shift shall be established on an 8 hour basis, and receive the regular wage rate plus 15%.
- When a three shift schedule is established, the first shift shall be established on an 8 hour basis, the second shift on a 7.5 hour basis, and the third shift on a 7 hour basis. The first shift shall receive the regular wage rate, the second shift shall receive the regular wage rate plus 15% and the third shift shall receive the regular wage rate plus 20%.
- When there is no day shift, and a second or third shift is established, it shall be established on an 8 hour basis. The second shift shall receive the regular wage rate plus 15% and the third shift shall receive the regular wage rate plus 20%.

OVERTIME:

- Hours in excess of 8 per day or 40 per week, or before or after the regular workday, Monday through Friday, shall be paid at time and one-half the wage rate. Saturday may be used as a make-up day, at straight time, up to 8 hours, for hours lost to reasons beyond the control of the employer, up to a total of 40 hours per week; hours in excess of 8 on Saturday shall then be paid at time and one-half the wage rate. If Saturday is not a make-up day, all hours on Saturday shall be paid at time and one-half the wage rate. All hours on Sundays and holidays shall be paid at double the wage rate.
- Four 10-hour days may be worked, Monday to Thursday, at straight time. Friday may be used as a make-up day for hours lost to reasons beyond the control of the employer. If Friday is not a make-up day, all hours on Friday shall be paid at time and one-half the wage rate.

**NEW JERSEY DEPARTMENT OF LABOR AND WORKFORCE DEVELOPMENT
PREVAILING WAGE RATE DETERMINATION**

County - UNION

RECOGNIZED HOLIDAYS: New Year's Day, Presidents' Day, Memorial Day, July 4th, Labor Day, Presidential Election Day, Veterans' Day, Thanksgiving Day, Christmas Day. Sunday holidays will be observed the following Monday.

**NEW JERSEY DEPARTMENT OF LABOR AND WORKFORCE DEVELOPMENT
PREVAILING WAGE RATE DETERMINATION**

County - UNION

Craft: Cement Mason

PREVAILING WAGE RATE

See "Bricklayer, Stone Mason" Rates

Craft: Cement Mason

APPRENTICE RATE SCHEDULE

INTERVAL	PERIOD AND RATES									

Ratio of Apprentices to Journeymen - 1:4

Craft: Cement Mason

COMMENTS/NOTES

See "Bricklayer, Stone Mason" Rates

**NEW JERSEY DEPARTMENT OF LABOR AND WORKFORCE DEVELOPMENT
PREVAILING WAGE RATE DETERMINATION**

County - UNION

Craft: Dockbuilder PREVAILING WAGE RATE

	11/29/16	05/01/17	11/01/17	05/01/18	11/01/18
Foreman	W51.29 B44.37 T95.66	W0.00 B0.00 T96.79	W0.00 B0.00 T97.99	W0.00 B0.00 T99.24	W0.00 B0.00 T100.49
Foreman (Concrete Form Work)	W50.14 B31.56 T81.70	W0.00 B0.00 T82.90	W0.00 B0.00 T84.10	W0.00 B0.00 T85.35	W0.00 B0.00 T86.60
Journeyman	W44.60 B44.37 T88.97	W0.00 B0.00 T90.17	W0.00 B0.00 T91.37	W0.00 B0.00 T92.62	W0.00 B0.00 T93.87
Journeyman (Concrete Form Work)	W43.60 B31.56 T75.16	W0.00 B0.00 T76.36	W0.00 B0.00 T77.56	W0.00 B0.00 T78.81	W0.00 B0.00 T80.06

Craft: Dockbuilder APPRENTICE RATE SCHEDULE

<u>INTERVAL</u>	<u>PERIOD AND RATES</u>									
Yearly	17.84	22.30	28.99	35.68						
Benefit	29.95	for all	intervals		Concrete	Form Work	Only Ben.	= 21.81	for all	intervals

Ratio of Apprentices to Journeymen - *

* When there are 4 or fewer Dockbuilders on a job, no more than 1 may be an apprentice. When there are 5 or more Dockbuilders, there may be 1 apprentice for every 5 Dockbuilders.

Craft: Dockbuilder COMMENTS/NOTES

CREOSOTE HANDLING:

When handling creosote products on land piledriving, floating marine construction, and construction of wharves, the worker shall receive an additional \$0.25 per hour.

HAZARDOUS WASTE WORK:

- Hazardous waste removal work on a state or federally designated hazardous waste site where Level A, B, or C personal protection is required: an additional 20% of the hourly rate, per hour.
- Hazardous waste removal work in Level D, or where personal protection is not required: an additional \$1.00 per hour.

CERTIFIED WELDER: When required on the job by the project owner, a Certified Welder shall receive an additional \$1.00 per hour.

FOREMAN REQUIREMENTS:

The first Dockbuilder on the job shall be designated a Foreman.

OVERTIME:

Hours in excess of 8 per day, Monday through Friday, and all hours on Saturdays shall be paid at time and one-half the hourly rate. All hours on Sundays and holidays shall be paid at double the hourly rate.

**NEW JERSEY DEPARTMENT OF LABOR AND WORKFORCE DEVELOPMENT
PREVAILING WAGE RATE DETERMINATION**

County - UNION

RECOGNIZED HOLIDAYS: New Year's Day, Presidents' Day, Memorial Day, July 4th, Labor Day, Veterans' Day, Presidential Election Day, Thanksgiving Day, Christmas Day. Veterans' Day may be switched with the day after Thanksgiving.

**NEW JERSEY DEPARTMENT OF LABOR AND WORKFORCE DEVELOPMENT
PREVAILING WAGE RATE DETERMINATION**

County - UNION

Craft: Drywall Finisher

PREVAILING WAGE RATE

	05/01/16	05/01/17
Foreman	W42.55 B23.10 T65.65	W44.30 B22.60 T66.90
General Foreman	W44.45 B23.10 T67.55	W46.20 B22.60 T68.80
Journeyman	W38.75 B23.10 T61.85	W40.50 B22.60 T63.10

Craft: Drywall Finisher

APPRENTICE RATE SCHEDULE

INTERVAL	PERIOD AND RATES									
	30%	40%	50%	60%	70%	75%	80%	85%	90%	
4 Months										
Benefits	Intervals	1 to 3 =	9.85	Intervals	4 to 6 =	12.28	Intervals	7 to 9 =	14.95	

Ratio of Apprentices to Journeymen - 1:4

Craft: Drywall Finisher

COMMENTS/NOTES

The regular workday shall consist of 8 hours between 7:00 AM and 5:30 PM.

SHIFT DIFFERENTIALS:

- The second shift shall receive an additional 10% of the hourly rate, per hour, and the third shift shall receive an additional 15% of the hourly rate, per hour.
- When 3 shifts are worked, the second shift shall receive 8 hours pay for 7.5 hours of work, and the third shift shall receive 8 hours pay for 7 hours of work.
- Shift work must run for a minimum of 5 consecutive workdays.

OVERTIME:

- Hours in excess of 8 per day, Monday through Friday, and all hours on Saturdays shall be paid at time and one-half the regular rate, inclusive of benefits. All hours on Sundays and holidays shall be paid at double the regular rate, inclusive of benefits.
- Saturday or Sunday may be used to make up a day lost to inclement weather, at straight time.

RECOGNIZED HOLIDAYS: New Year's Day, Memorial Day, July 4th, Labor Day, Presidential Election Day, Veterans' Day, Thanksgiving Day, Christmas Day. Saturday holiday observed the preceding Friday. Sunday holiday observed the following Monday.

**NEW JERSEY DEPARTMENT OF LABOR AND WORKFORCE DEVELOPMENT
PREVAILING WAGE RATE DETERMINATION**

County - UNION

Craft: Electrician

PREVAILING WAGE RATE

	05/30/16	05/29/17	05/28/18
Cable Splicer	W58.71 B33.74 T92.45	W60.08 B34.53 T94.61	W61.52 B35.35 T96.87
Foreman	W59.77 B34.34 T94.11	W61.17 B35.15 T96.32	W62.64 B35.98 T98.62
Journeyman	W53.37 B30.67 T84.04	W54.62 B31.39 T86.01	W55.93 B32.13 T88.06

Craft: Electrician

APPRENTICE RATE SCHEDULE

INTERVAL	PERIOD AND RATES									
	Yearly	40%	49%	58%	68%	80%		of Jour	neyman	Wage
Benefit	40%	49%	58%	68%	80%		of Jour	neyman	Benefit	Rate

Ratio of Apprentices to Journeymen - 2:3

Craft: Electrician

COMMENTS/NOTES

THESE RATES ALSO APPLY TO THE FOLLOWING:

- All burglar and fire alarm work.
- All fiber optic work.
- Teledata work in new construction.
- Teledata work involving 16 Voice/Data Lines or more.

The regular workday shall be 8 hours, between 8:00 AM and 4:30 PM.

FOREMAN REQUIREMENTS:

- On any job where there are 1 to 10 Journeymen electricians, 1 shall be designated a Foreman.

SHIFT DIFFERENTIALS:

- Shift work must run for a minimum of 5 consecutive workdays.
- 2nd Shift (4:30 PM to 12:30 AM) shall receive 8 hours pay for 7.5 hours work + an additional 10% of the regular rate, per hour, inclusive of benefits.
- 3rd Shift (12:30 AM to 8:00 AM) shall receive 8 hours pay for 7 hours work + an additional 15% of the regular rate, per hour, inclusive of benefits.

OVERTIME:

Hours in excess of 8 per day, or outside of the regular workday, Monday through Friday, and all hours on Saturdays, shall be paid at time and one-half the regular rate, inclusive of benefits. All hours on Sundays and holidays shall be paid at double the regular rate, inclusive of benefits.

**NEW JERSEY DEPARTMENT OF LABOR AND WORKFORCE DEVELOPMENT
PREVAILING WAGE RATE DETERMINATION**

County - UNION

RECOGNIZED HOLIDAYS: New Year's Day, Presidents' Day, Memorial Day, July 4th, Labor Day, Presidential Election Day, Veterans' Day, Thanksgiving Day, Christmas Day.

**NEW JERSEY DEPARTMENT OF LABOR AND WORKFORCE DEVELOPMENT
PREVAILING WAGE RATE DETERMINATION**

County - UNION

Craft: Electrician - Teledata (15 Voice/Data Lines & Less)

PREVAILING WAGE RATE

	11/01/16
Master Technician/General Foreman	W52.18 B28.69 T80.87
Senior Technician/Lead Foreman (21-30 Workers on Job)	W47.77 B26.26 T74.03
Technician A/Foreman (11-20 Workers on Job)	W45.76 B25.16 T70.92
Technician B/Working Foreman (4-10 Workers on Job)	W43.75 B24.06 T67.81
Technician C/Journeyman (1-3 Workers on Job)	W40.14 B22.07 T62.21

Craft: Electrician - Teledata (15 Voice/Data Lines & Less)

APPRENTICE RATE SCHEDULE

<u>INTERVAL</u>	<u>PERIOD AND RATES</u>									
6 Months	20.14	21.48	23.72	26.41	29.54	32.23	35.36	38.49		
Benefits	7.85	8.38	9.25	10.29	11.52	12.56	13.79	15.01		

Ratio of Apprentices to Journeymen - 2:3

Craft: Electrician - Teledata (15 Voice/Data Lines & Less)

COMMENTS/NOTES

APPRENTICE RATE SCHEDULE FOR THOSE APPRENTICES ENTERING PROGRAM AFTER 10-31-14:

INTERVAL	PERIOD AND RATES									
6 Months	17.90	19.25	21.48	24.17	27.30	29.99	33.12	36.26		
Benefits	6.98	7.51	8.38	9.42	10.65	11.69	12.92	14.13		

NOTES:

- These rates are for service, maintenance, moves, and/or changes affecting 15 Voice/Data (teledata) lines or less. These rates may NOT be used for any teledata work in new construction (including additions) or any fiber optic work.
- The number of Teledata workers on the jobsite is the determining factor for which Foreman category applies .

The regular workday shall be 8 hours, between 8:00 AM and 4:30 PM.

SHIFT DIFFERENTIALS:

- Shift work must run for a minimum of 5 consecutive workdays.

**NEW JERSEY DEPARTMENT OF LABOR AND WORKFORCE DEVELOPMENT
PREVAILING WAGE RATE DETERMINATION**

County - UNION

- 2nd Shift (4:30 PM to 12:30 AM) shall receive 8 hours pay for 7.5 hours work + an additional 10% of the regular rate, per hour, inclusive of benefits.
- 3rd Shift (12:30 AM to 8:00 AM) shall receive 8 hours pay for 7 hours work + an additional 15% of the regular rate, per hour, inclusive of benefits.

OVERTIME:

Hours in excess of 8 per day, or outside of the regular workday, Monday through Friday, and all hours on Saturdays, shall be paid at time and one-half the regular rate, inclusive of benefits. All hours on Sundays and holidays shall be paid at double the regular rate, inclusive of benefits.

RECOGNIZED HOLIDAYS: New Year's Day, Presidents' Day, Memorial Day, July 4th, Labor Day, Presidential Election Day, Veterans' Day, Thanksgiving Day, Christmas Day.

**NEW JERSEY DEPARTMENT OF LABOR AND WORKFORCE DEVELOPMENT
PREVAILING WAGE RATE DETERMINATION**

County - UNION

Craft: Electrician - Teledata (16 Instruments & More)

PREVAILING WAGE RATE

See "Electrician" Rates

Craft: Electrician - Teledata (16 Instruments & More)

COMMENTS/NOTES

See ELECTRICIAN Rates

**NEW JERSEY DEPARTMENT OF LABOR AND WORKFORCE DEVELOPMENT
PREVAILING WAGE RATE DETERMINATION**

County - UNION

Craft: Electrician- Outside Commercial

PREVAILING WAGE RATE

	05/30/16	05/29/17	05/28/18
Cable Splicer	W58.99 B33.46 T92.45	W60.37 B34.24 T94.61	W61.82 B35.06 T96.88
Certified Welder	W56.31 B31.94 T88.25	W57.62 B32.68 T90.30	W59.01 B33.47 T92.48
Equipment Operator	W53.63 B30.42 T84.05	W54.88 B31.13 T86.01	W56.20 B31.88 T88.08
Foreman (1-10 Journeyman workers on job)	W60.07 B34.07 T94.14	W61.47 B34.86 T96.33	W62.94 B35.70 T98.64
Foreman (11-20 Journeyman workers on job)	W61.67 B34.98 T96.65	W63.11 B35.79 T98.90	W64.63 B36.66 T101.29
General Foreman (21-30 Journeyman workers on job)	W63.28 B35.89 T99.17	W64.76 B36.73 T101.49	W66.32 B37.61 T103.93
General Foreman (31-60 Journeyman workers on job)	W68.65 B38.94 T107.59	W70.25 B39.84 T110.09	W71.94 B40.80 T112.74
General Foreman (61+ Journeyman workers on job)	W69.72 B39.54 T109.26	W71.34 B40.46 T111.80	W73.06 B41.44 T114.50
Groundman	W32.18 B18.26 T50.44	W32.93 B18.68 T51.61	W33.72 B19.13 T52.85
Journeyman Lineman/Technician	W53.63 B30.42 T84.05	W54.88 B31.13 T86.01	W56.20 B31.88 T88.08
Sub-Foreman	W60.07 B34.07 T94.14	W61.47 B34.86 T96.33	W62.94 B35.70 T98.64

**NEW JERSEY DEPARTMENT OF LABOR AND WORKFORCE DEVELOPMENT
PREVAILING WAGE RATE DETERMINATION**

County - UNION

Craft: Electrician- Outside Commercial

APPRENTICE RATE SCHEDULE

INTERVAL	PERIOD AND RATES									
1000 Hours	60%	65%	70%	75%	80%	85%	90%			
Benefits	56.4% of	Journey	man	wage	+	\$.01				

Craft: Electrician- Outside Commercial

COMMENTS/NOTES

EFFECTIVE 5-30-16- The apprentice benefit rate shall be 56.7% + \$.01.
 EFFECTIVE 5-29-17- The apprentice benefit rate shall be 56.7% + \$.01.
 EFFECTIVE 5-28-18- The apprentice benefit rate shall be 56.7% + \$.01.

* FOR UTILITY WORK PLEASE SEE STATEWIDE RATES

The regular worday shall be 8 hours, between 8:00 AM and 4:30 PM.

FOREMAN REQUIREMENTS:

On jobs where there are 2 Journeymen, one shall be a Foreman. The following number of Foreman, General Foreman, Assistant General Foreman and Sub-Foreman shall be required with respect to number of Journeymen on site:

- 2-10 Journeymen (1 Foreman)
- 11-20 Journeymen (1 Foreman and 1 Sub-Foreman)
- 21-30 Journeymen (1 Foreman and 2 Sub-Foremen)

SHIFT DIFFERENTIALS:

- Shift work must run for a minimum of 5 consecutive workdays.
- 2nd Shift (4:30 PM to 12:30 AM): 8 hrs. pay for 7.5 hrs. work + an additional 10% of the regular rate, inclusive of benefits.
- 3rd Shift (12:30 AM to 8:00 AM): 8 hrs. pay for 7 hrs. work + an additional 15% of the regular rate per hour, inclusive benefits.

OVERTIME:

Hours in excess of 8 per day, or outside of the regular workday, Monday through Friday, and all hours on Saturdays, shall be paid at time and one-half the regular rate, inclusive of benefits. All hours on Sundays and holidays shall be paid at double the regular rate, inclusive of benefits.

RECOGNIZED HOLIDAYS:

New Year's Day, Presidents' Day, Memorial Day, July 4th, Labor Day, Presidential Election Day, Veterans' Day, Thanksgiving Day and Christmas Day.

**NEW JERSEY DEPARTMENT OF LABOR AND WORKFORCE DEVELOPMENT
PREVAILING WAGE RATE DETERMINATION**

County - UNION

Craft: Electrician-Utility Work (North)

PREVAILING WAGE RATE

Rates are located in the "Statewide" rate package

Craft: Electrician-Utility Work (North)

APPRENTICE RATE SCHEDULE

INTERVAL	PERIOD AND RATES									
6 Months	60%	65%	70%	75%	80%	85%	90%			
Benefits	62.5% of	Appren	tice	Wage	Rate	for all	intervals			

Craft: Electrician-Utility Work (North)

COMMENTS/NOTES

Electrician-Utility Work (North) rates are located in the "Statewide" rate package.

**NEW JERSEY DEPARTMENT OF LABOR AND WORKFORCE DEVELOPMENT
PREVAILING WAGE RATE DETERMINATION**

County - UNION

Craft: Electrician-Utility Work (South)

PREVAILING WAGE RATE

Rates are located in the "Statewide" rate package

Craft: Electrician-Utility Work (South)

APPRENTICE RATE SCHEDULE

INTERVAL	PERIOD AND RATES									
6 Months	27.37	29.65	31.93	34.21	36.49	38.77	41.05			
Benefits	24.01	25.34	26.73	28.09	29.43	30.80	32.18			

Craft: Electrician-Utility Work (South)

COMMENTS/NOTES

Electrician-Utility Work (South) rates are located in the "Statewide" rate package.

**NEW JERSEY DEPARTMENT OF LABOR AND WORKFORCE DEVELOPMENT
PREVAILING WAGE RATE DETERMINATION**

County - UNION

Craft: Elevator Constructor PREVAILING WAGE RATE

	03/17/17	03/17/18
Journeyman	W62.64 B41.56 T104.20	W64.48 B43.36 T107.84

Craft: Elevator Constructor APPRENTICE RATE SCHEDULE

INTERVAL	PERIOD AND RATES									
Yearly	27.22	33.53	39.62	45.72						
Benefits	31.75	32.88	34.41	35.93						

Ratio of Apprentices to Journeymen - 1:1

Craft: Elevator Constructor COMMENTS/NOTES

The regular workday shall consist of either 7 or 8 hours to be established at the beginning of the project, between 7:00 AM and 4:30 PM.

OVERTIME:

For all hours worked before or after the regular workday, Monday through Friday, and all hours on Saturday and Sunday, shall be paid at double the hourly rate. Holiday pay is one days wages (8 hours) plus double the hourly rate for all hours worked.

RECOGNIZED HOLIDAYS: New Year's Day, Presidents' Day, Good Friday, Memorial Day, July 4th, Labor Day, Columbus Day, Veterans' Day, Thanksgiving Day and the day after, Christmas Day. Saturday holidays shall be observed on the previous Friday and Sunday holidays shall be observed on the following Monday.

**NEW JERSEY DEPARTMENT OF LABOR AND WORKFORCE DEVELOPMENT
PREVAILING WAGE RATE DETERMINATION**

County - UNION

Craft: Elevator Modernization & Service

PREVAILING WAGE RATE

	03/17/17	03/17/18
Journeyman	W49.14	W50.49
	B39.91	B41.66
	T89.05	T92.15

Craft: Elevator Modernization & Service

APPRENTICE RATE SCHEDULE

INTERVAL	PERIOD AND RATES									
Yearly	27.22	26.35	31.14	35.93						
Benefits	31.68	31.99	33.37	34.74						

Ratio of Apprentices to Journeymen - 1:1

Craft: Elevator Modernization & Service

COMMENTS/NOTES

MODERNIZATION (addition, replacement, refurbishing, relocation, or changes in design or appearance, of elevator equipment in existing buildings):

- The regular workday consists of 8 hours, between 7:00 AM and 4:30 PM.

- Overtime:

Hours in excess of 8 per day, or before or after the regular workday, Monday through Friday, and all hours on Saturday and Sunday shall be paid at time and one-half the hourly rate. Holiday pay is one days wages (8 hours) plus time and one-half the hourly rate for all hours worked.

SERVICE (repair or replacement of parts for the purpose of maintaining elevator equipment in good operating condition):

- The regular workday consists of 8 hours, between 6:00 AM and 6:00 PM.

- Overtime:

Hours in excess of 8 per day, or before or after the regular workday, Monday through Friday, and all hours on Saturday shall be paid at time and one-half the hourly rate. All hours on Sunday and holidays shall be paid at double the hourly rate.

RECOGNIZED HOLIDAYS (Modernization and Service): New Year's Day, Presidents' Day, Good Friday, Memorial Day, July 4th, Labor Day, Columbus Day, Veterans' Day, Thanksgiving Day and the day after, Christmas Day. Saturday holidays shall be observed on the previous Friday and Sunday holidays shall be observed on the following Monday.

**NEW JERSEY DEPARTMENT OF LABOR AND WORKFORCE DEVELOPMENT
PREVAILING WAGE RATE DETERMINATION**

County - UNION

Craft: Glazier PREVAILING WAGE RATE

	06/20/16
Foreman	W47.39 B23.26 T70.65
General Foreman	W49.39 B23.50 T72.89
Journeyman	W43.39 B22.78 T66.17

Craft: Glazier APPRENTICE RATE SCHEDULE

INTERVAL	PERIOD AND RATES									
	30%	40%	50%	60%	70%	75%	80%	85%	90%	
4 Months										
Benefits	Intervals	1 to 3 =	6.51	Intervals	4 to 6 =	9.33	Intervals	7 to 9 =	11.67	

Ratio of Apprentices to Journeymen - 1:4

Craft: Glazier COMMENTS/NOTES

APPRENTICE RATE SCHEDULE FOR THOSE APPRENTICES ENTERING PROGRAM AS OF 5-1-14:

INTERVAL	PERIOD AND RATES							
6 Months	50%	55%	60%	65%	70%	75%	80%	90%
Benefits	8.10	8.10	10.34	10.34	11.51	11.51	14.62	14.62

Hazard/Height Pay: +\$1.00 per hour

FOREMAN REQUIREMENTS:

- When there are 4 or more Glaziers on a job, 1 must be designated a Foreman.
- When there are 15 or more Glaziers on a job, 1 must be designated a General Foreman.

The regular workday shall consist of 8 hours, between 7:00 AM and 5:30 PM, Monday to Friday.

SHIFT DIFFERENTIALS:

- The second shift shall receive an additional 10% of the hourly rate, per hour, and the third shift shall receive an additional 15% of the hourly rate, per hour.
- When 3 shifts are worked, the second shift shall receive 8 hours pay for 7.5 hours of work, and the third shift shall receive 8 hours pay for 7 hours of work.

OVERTIME:

Hours in excess of 8 per day, or before or after the regular workday Monday through Friday, and all hours on Saturdays shall be paid at time and one-half the regular rate. All hours on Sundays and holidays shall be paid at double the regular rate.

**NEW JERSEY DEPARTMENT OF LABOR AND WORKFORCE DEVELOPMENT
PREVAILING WAGE RATE DETERMINATION**

County - UNION

RECOGNIZED HOLIDAYS: New Year's Day, Memorial Day, July 4th, Labor Day, General Election Day, Veterans' Day, Thanksgiving Day, Christmas Day. Saturday holiday observed the preceding Friday. Sunday holiday observed the following Monday.

**NEW JERSEY DEPARTMENT OF LABOR AND WORKFORCE DEVELOPMENT
PREVAILING WAGE RATE DETERMINATION**

County - UNION

Craft: Heat & Frost Insulator

PREVAILING WAGE RATE

	10/17/16
Foreman	W52.52 B30.17 T82.69
General Foreman	W55.07 B31.28 T86.35
Journeyman	W51.24 B29.61 T80.85

Craft: Heat & Frost Insulator

APPRENTICE RATE SCHEDULE

INTERVAL	PERIOD AND RATES									
Yearly	23.77	28.19	34.05	39.96						
Benefits	17.83	21.08	23.21	25.16						

Ratio of Apprentices to Journeymen - 1:3

Craft: Heat & Frost Insulator

COMMENTS/NOTES

NOTE: These rates apply to the installing of insulation on hot and cold mechanical systems.

The regular workday shall be 8 hours between 8:00 AM and 4:30 PM.

SHIFT DIFFERENTIAL:

- Shift work must run for a minimum of 5 consecutive workdays.
- Second Shift shall work 7.5 hours and receive 8 hours pay, at the regular rate, plus 25% per hour.
- Third Shift shall work 7 hours and receive 8 hours pay, at the regular rate, plus 30% per hour.

OVERTIME:

The first 2 hours in excess of 8 per day, hours outside of the regular workday Monday through Friday that are not shift work, and the first 10 hours on Saturday, shall be paid at time and one-half the regular rate, inclusive of benefits. All hours in excess of 10 per day, and all hours on Sunday and holidays (except Labor Day) shall be paid at double the regular rate, inclusive of benefits. All hours on Labor Day shall be paid at triple the regular rate, inclusive of benefits.

RECOGNIZED HOLIDAYS: New Year's Day, President's Day, Memorial Day, July 4th, Labor Day, Veterans' Day, Presidential Election Day, Thanksgiving Day and Christmas Day. Sunday holidays observed the following Monday.

**NEW JERSEY DEPARTMENT OF LABOR AND WORKFORCE DEVELOPMENT
PREVAILING WAGE RATE DETERMINATION**

County - UNION

Craft: Heat & Frost Insulator - Asbestos Worker

PREVAILING WAGE RATE

	10/17/16
Asbestos Helper Abatement	W33.52 B22.69 T56.21
Firestop/Hazmat	W26.93 B9.25 T36.18
Foreman	W52.52 B30.17 T82.69

Craft: Heat & Frost Insulator - Asbestos Worker

APPRENTICE RATE SCHEDULE

INTERVAL	PERIOD AND RATES									
	SEE	HEAT &	FROST	INSULAT OR						

Ratio of Apprentices to Journeymen - 1:3

Craft: Heat & Frost Insulator - Asbestos Worker

COMMENTS/NOTES

NOTE: These rates apply only to the removal of insulation materials/asbestos from mechanical systems, including containment erection and demolition, and placing material in appropriate containers.

The regular workday shall be 8 hours between 8:00 AM and 4:30 PM.

SHIFT DIFFERENTIALS:

- Shift work must run for a minimum of 5 consecutive workdays.
- The second shift shall work 7.5 hours and receive 8 hours pay at the regular rate, plus 25% per hour.
- The third shift shall work 7 hours and receive 8 hours pay at the regular rate, plus 30% per hour.

OVERTIME: The first 2 hours in excess of 8 per day, hours outside of the regular workday Monday through Friday that are not shift work, and the first 10 hours on Saturday, shall be paid at time and one-half the regular rate, inclusive of benefits. All hours in excess of 10 per day, and all hours on Sunday and holidays (except Labor Day) shall be paid at double the regular rate, inclusive of benefits. All hours on Labor Day shall be paid at triple the regular rate, inclusive of benefits.

RECOGNIZED HOLIDAYS: New Year's Day, Presidents' Day, Memorial Day, July 4th, Labor Day, Veterans' Day, Presidential Election Day, Thanksgiving Day and Christmas Day. Sunday holidays observed the following Monday.

**NEW JERSEY DEPARTMENT OF LABOR AND WORKFORCE DEVELOPMENT
PREVAILING WAGE RATE DETERMINATION**

County - UNION

Craft: Ironworker PREVAILING WAGE RATE

	08/02/16	07/01/17
Rod /Fence Foreman	W42.24 B44.27 T86.51	W0.00 B0.00 T88.51
Rod/Fence Journeyman	W39.24 B44.27 T83.51	W0.00 B0.00 T85.51
Structural Foreman	W44.54 B44.27 T88.81	W0.00 B0.00 T90.56
Structural Journeyman	W41.54 B44.27 T85.81	W0.00 B0.00 T87.56

Craft: Ironworker APPRENTICE RATE SCHEDULE

<u>INTERVAL</u>	<u>PERIOD AND RATES</u>									
6 Months	50%	60%		Yearly	70%	80%	90%			

Ratio of Apprentices to Journeymen - 1:4

Craft: Ironworker COMMENTS/NOTES

HAZARDOUS WASTE WORK: On hazardous waste removal work on a state or federally designated hazardous waste site where the Ironworker is required to wear Level A,B, or C personal protection: + \$3.00 per hour

The regular workday consists of 8 hours between 6:00 AM and 4:30 PM.

FOREMAN REQUIREMENTS:

When there are 2 or more Ironworkers on a job, 1 shall be designated a Foreman.

SHIFT DIFFERENTIALS:

- When a 2 shift schedule is established, the first, or day shift , shall be established on an 8 hour basis .The second shift shall be established on an 8 hour basis, and receive the regular rate plus 15%.
- When a three shift schedule is established, the first shift shall be established on an 8 hour basis, the second shift on a 7.5 hour basis, and the third shift on a 7 hour basis. The first shift shall receive the regular hourly rate, the second shift shall receive the regular rate plus 15%, and the third shift shall receive the regular rate plus 20%.
- When there is no day shift, and a second or third shift is established, it shall be established on an 8 hour basis.
- When an irregular shift is established for the Ironworker (Structural) classification, the rate shall be paid at time and one-half the regular rate, inclusive of benefits. When an irregular shift is established for the Rod/Fence classification, the shift shall be established on an 8 hour basis and receive the regular rate, plus 20%.

OVERTIME:

**NEW JERSEY DEPARTMENT OF LABOR AND WORKFORCE DEVELOPMENT
PREVAILING WAGE RATE DETERMINATION**

County - UNION

- All hours in excess of 8 per day, or before or after an established shift that are not shift work, and all hours on Saturday, shall be paid at time and one-half the regular rate, inclusive of benefits. All hours on Sunday and holidays shall be paid at double the hourly rate, inclusive of benefits. Saturday may be used as a make-up day for a day lost to inclement weather. If Saturday is not a make-up day, all hours on Saturday shall be paid at time and one-half the hourly rate, inclusive of benefits.

- Four 10-hour days may be worked, Monday to Thursday, at straight time. Friday may be used as a make-up day for a day lost to inclement weather. If Friday is not a make-up day, all hours on Friday shall be paid at time and one-half the hourly rate, inclusive of benefits.

RECOGNIZED HOLIDAYS: New Year's Day, Presidents' Day, Memorial Day, July 4th, Labor Day, Presidential Election Day, Veterans Day, Thanksgiving Day, Christmas Day.

**NEW JERSEY DEPARTMENT OF LABOR AND WORKFORCE DEVELOPMENT
PREVAILING WAGE RATE DETERMINATION**

County - UNION

Craft: Laborer - Asbestos & Hazardous Waste Removal

PREVAILING WAGE RATE

	01/26/17
Journeyman (Handler)	W30.88 B21.91 T52.79

Craft: Laborer - Asbestos & Hazardous Waste Removal

APPRENTICE RATE SCHEDULE

INTERVAL	PERIOD AND RATES									
Yearly	18.53	21.62	24.70	27.79						
Benefits	20.26	for	all	intervals						

Ratio of Apprentices to Journeymen - *

* Ratio of apprentices to journeymen shall not be more than one apprentice for the first journeyman and no more than (1) apprentice for each additional three (3) journeymen.

Craft: Laborer - Asbestos & Hazardous Waste Removal

COMMENTS/NOTES

NOTE: These rates apply to work in connection with Asbestos, Radiation, Hazardous Waste, Lead, Chemical, Biological, Mold Remediation and Abatement.

The regular workday shall be 8 hours between 6:00 AM and 6:00 PM.

OVERTIME:

- Hours in excess of 8 per day, Monday through Saturday, and all hours on Sunday and holidays shall be paid at time and one-half the regular rate.
- When the owner (Public Body) mandates that work is to be performed on Sunday, those hours may be worked at straight time, up to 8 hours per day, up to 40 hours per week.
- Benefits on ALL overtime hours shall be paid at straight time.

RECOGNIZED HOLIDAYS: New Year's Day, President's Day, Good Friday, Easter, Memorial Day, July 4th, Labor Day, Presidential Election Day, Veterans' Day, Thanksgiving Day, Christmas Day.

**NEW JERSEY DEPARTMENT OF LABOR AND WORKFORCE DEVELOPMENT
PREVAILING WAGE RATE DETERMINATION**

County - UNION

Craft: Laborer - Building

PREVAILING WAGE RATE

	11/01/16	05/01/17	11/01/17	05/01/18
Class A Journeyman	W31.55	W0.00	W0.00	W0.00
	B27.22	B0.00	B0.00	B0.00
	T58.77	T59.67	T60.72	T62.57
Class B Journeyman	W31.05	W0.00	W0.00	W0.00
	B27.22	B0.00	B0.00	B0.00
	T58.27	T59.17	T60.22	T62.07
Class C Journeyman	W26.43	W0.00	W0.00	W0.00
	B27.22	B0.00	B0.00	B0.00
	T53.65	T54.55	T55.60	T57.45
Foreman	W35.46	W0.00	W0.00	W0.00
	B27.22	B0.00	B0.00	B0.00
	T62.68	T63.58	T64.63	T66.48
General Foreman	W39.38	W0.00	W0.00	W0.00
	B27.22	B0.00	B0.00	B0.00
	T66.60	T67.50	T68.55	T70.40

Craft: Laborer - Building

APPRENTICE RATE SCHEDULE

INTERVAL	PERIOD AND RATES									
	60%	70%	80%	90%						
6 Months										
Benefit	23.97	23.97	23.97	23.97						

Ratio of Apprentices to Journeymen - *

* Ratio of apprentices to journeymen shall not be more than one apprentice for the first journeyman and no more than (1) apprentice for each additional three (3) journeymen.

Craft: Laborer - Building

COMMENTS/NOTES

CLASS A: Specialist laborer including mason tender or concrete pour crew; scaffold builder (scaffolds up to 14 feet in height); operator of forklifts, Bobcats (or equivalent machinery), jack hammers, tampers, motorized tampers and compactors, vibrators, street cleaning machines, hydro demolition equipment, riding motor buggies, conveyors, burners; and nozzlemen on gunite work.

CLASS B: Basic laborer - includes all laborer work not listed in Class A or Class C.

CLASS C: Janitorial-type light clean-up work associated with the TURNOVER of a project, or part of a project, to the owner. All other clean-up work is Class B.

The regular workday shall be 8 hours between 6:00 AM and 6:00 PM.

SHIFT DIFFERENTIALS:

- Shift work must run for a minimum of 5 consecutive workdays.
- When a 2-shift schedule is worked, including a day shift, both shifts shall be established on the basis of 8 hours pay for 8 hours worked. The second shift shall receive the regular rate plus an additional 10%.
- When a 3-shift schedule is worked, the day shift shall be established on the basis of 8 hours pay for 8 hours worked, the second shift shall be established on the basis of 8 hours pay for 7.5 hours worked, and the third shift shall be established

**NEW JERSEY DEPARTMENT OF LABOR AND WORKFORCE DEVELOPMENT
PREVAILING WAGE RATE DETERMINATION**

County - UNION

on the basis of 8 hours pay for 7 hours worked. The day shift shall receive the regular rate, the second shift shall receive the regular rate plus an additional 10%, and the third shift shall receive the regular rate plus an additional 15%.

- When a second or third shift is worked with no day shift, the second or third shift shall be established on the basis of 8 hours pay for 8 hours worked. The second shift shall receive the regular rate plus an additional 10%, and the third shift shall receive the regular rate plus an additional 15%.

OVERTIME:

- Hours in excess of 8 per day, or outside the regular workday that are not shift work, Monday through Friday, and all hours on Saturdays shall be paid at time and one-half the regular rate. Saturday may be used as a make-up day (paid at straight time) for a day lost to inclement weather, or for a holiday that is observed during the work week, Monday through Friday. All hours on Sundays and holidays shall be paid at double the regular rate.

- Four 10-hour days may be worked Monday to Thursday, at straight time, with Friday used a make-up day for a day lost to inclement weather. If Friday is not a make-up day, all hours on Friday shall be paid at time and one-half the regular rate.

- Benefits on ALL overtime hours shall be paid at time and one-half.

RECOGNIZED HOLIDAYS: New Year's Day, Presidents' Day, Memorial Day, July 4th, Labor Day, Presidential Election Day, Veterans' Day, Thanksgiving Day, Christmas Day. Sunday holidays observed the following Monday.

**NEW JERSEY DEPARTMENT OF LABOR AND WORKFORCE DEVELOPMENT
PREVAILING WAGE RATE DETERMINATION**

County - UNION

Craft: Laborer - Heavy & General

PREVAILING WAGE RATE

Rates are located in the
"Statewide" rate package

Craft: Laborer - Heavy & General

APPRENTICE RATE SCHEDULE

INTERVAL	PERIOD AND RATES									
1000 Hours	60%	70%	80%	90%						
Benefit	19.53	for	all	intervals						

Ratio of Apprentices to Journeymen - *

* No more than 1 apprentice for the first journeyman and no more than 1 apprentice for each additional 3 journeymen.

Craft: Laborer - Heavy & General

COMMENTS/NOTES

Heavy & General Laborer rates are located in the "Statewide" rate package.

**NEW JERSEY DEPARTMENT OF LABOR AND WORKFORCE DEVELOPMENT
PREVAILING WAGE RATE DETERMINATION**

County - UNION

Craft: Laborer-Residential and Modular Construction

PREVAILING WAGE RATE

	01/05/17	04/01/17
* Skilled Tradesman (only applies to Modular Construction)	W25.25 B5.45 T30.70	W25.55 B5.45 T31.00
Foreman (person directing crew, regardless of his skill classification)	W25.25 B5.45 T30.70	W25.55 B5.45 T31.00
Laborer	W21.25 B5.45 T26.70	W21.55 B5.45 T27.00
Laborer (for single family and stand-alone duplex owned by single owner)	W16.55 B2.95 T19.50	W17.05 B2.95 T20.00

Craft: Laborer-Residential and Modular Construction

APPRENTICE RATE SCHEDULE

<u>INTERVAL</u>	<u>PERIOD AND RATES</u>									
	As shown	800 hours	600 hours	600 hours						
wage & benefits	70%	80%	90%							

Ratio of Apprentices to Journeymen-

One (1) apprentice shall be allowed for the first journeyman on site and no more than one (1) additional apprentice for each additional three (3) journeymen on site.

Craft: Laborer-Residential and Modular Construction

COMMENTS/NOTES

* SKILLED TRADESMAN- any worker doing work not typically done by a Building Laborer. Some examples are installing interior doors, sheet rock, hooking up appliances, installing light fixtures, installing railing systems, etc. Please note where local building codes require that certain work be performed under the supervision of a licensed tradesman (i.e. Plumber, Electrician, etc.) Laborers shall work under such supervision.

RESIDENTIAL CONSTRUCTION- All residential construction (not commercial), single-family, stand-alone duplex houses, townhouses and multi-family buildings of not more than four (4) floors, including basement levels. Please note the construction must be residential in nature for ALL FLOORS at an elevation of no more than FOUR (4) FLOORS, INCLUDING BASEMENT. In addition, barracks and dormitories are not considered residential projects.

MODULAR RESIDENTIAL CONSTRUCTION- all aspects of modular residential construction (not commercial) at the site of installation of structures of no more than four (4) stories, including all excavation and site preparation, footings and foundation systems whether poured on-site or prefabricated, all underground waterproofing, underground utilities, concrete slabs, sidewalks, driveways, paving, hardscape and landscaping. Please note the construction must be residential in nature for ALL STORIES at an elevation of no more than FOUR (4) STORIES. All work performed by the Set Crew (the crew of workers who set the modular boxes on the foundation), including the rigging, setting, attaching and assembly of all modules and structural members, preparation of the foundation to accept modules, such as sill plates, connection of all in-module and under-module connections including, but not limited to, plumbing, electrical, HVAC, fire suppression, CATS,

**NEW JERSEY DEPARTMENT OF LABOR AND WORKFORCE DEVELOPMENT
PREVAILING WAGE RATE DETERMINATION**

County - UNION

telephone, television/internet, and fiber optic, the building or installation of any porches or decks regardless of material or method of construction, the on-site installation of, or completion of any roof system, doors, windows and fenestrations, including flashing, gutter and soffit systems, waterproofing, insulation and interior and exterior trim work, and painting. Please note that modular construction does not include on-site stick built construction, tip up construction or panel built construction.

The regular workday shall be 8 hours between 6:00 AM and 6:00 PM.

OVERTIME:

Hours worked in excess of 8 per day/40 per week, Monday through Saturday, and all hours worked on Sunday and holidays shall be paid at time and one-half the hourly rate.

RECOGNIZED HOILDAYS:

New Year's Day, Martin Luther King Day, Memorial Day, July 4th, Labor Day, Thanksgiving Day and Christmas Day.

**NEW JERSEY DEPARTMENT OF LABOR AND WORKFORCE DEVELOPMENT
PREVAILING WAGE RATE DETERMINATION**

County - UNION

Craft: Millwright PREVAILING WAGE RATE

	11/01/16
Foreman	W53.53 B31.65 T85.18
Journeyman	W46.55 B27.60 T74.15

Craft: Millwright APPRENTICE RATE SCHEDULE

INTERVAL	PERIOD AND RATES									
6 Months	40%	45%	50%	55%	60%	65%	70%	75%	85%	95%
Benefits	58% of	Appren	tice	Wage	Rate	for all	intervals	+ \$.60		

Ratio of Apprentices to Journeymen - 1:3

Craft: Millwright COMMENTS/NOTES

FOREMAN REQUIREMENTS:

- When there are 2 or more Millwrights on a job, 1 shall be designated as a Foreman.
- When there are 21 or more Millwrights on a job, 2 shall be designated as Foremen.

The regular workday shall consist of 8 hours, starting between 7:00 AM and 9:00 AM.

SHIFT DIFFERENTIALS:

- When a 2 shift schedule (including a day shift) is established, the day shift shall be established on an 8 hour basis. The second shift shall be established on an 8 hour basis, and receive the regular rate plus 15%, inclusive of benefits.
- When a three shift schedule is established, the first shift shall be established on an 8 hour basis, the second shift on a 7.5 hour basis, and the third shift on a 7 hour basis. The first shift shall receive the regular hourly rate, the second shift shall receive the regular rate plus 15% and the third shift shall receive the regular rate plus 20%, inclusive of benefits.
- When there is no day shift, and a second or third shift is established, it shall be established on an 8 hour basis. The second shift shall receive the regular rate plus 15% and the third shift shall receive the regular rate plus 20%, inclusive of benefits.

OVERTIME:

- All hours in excess of 8 per day, or before or after an established shift that are not shift work, and all hours on Saturdays shall be paid at time and one-half the hourly rate, inclusive of benefits. All hours on Sundays and holidays shall be paid at double the hourly rate, inclusive of benefits.
- Four 10-hour days may be worked, Monday to Thursday, at straight time. Friday may be used as a make-up day for a day lost due to inclement weather. If Friday is not a make-up day, all hours on Friday shall be paid at time and one-half the hourly rate, inclusive of benefits.

RECOGNIZED HOLIDAYS: New Year's Day, Presidents' Day, Memorial Day, July 4th, Labor Day, Presidential Election Day, Veterans' Day, Thanksgiving Day, Christmas Day. Sunday holidays will be observed the following Monday.

**NEW JERSEY DEPARTMENT OF LABOR AND WORKFORCE DEVELOPMENT
PREVAILING WAGE RATE DETERMINATION**

County - UNION

Craft: Operating Engineer - Field Engineer

PREVAILING WAGE RATE

Rates are located in the
"Statewide" rate package

Craft: Operating Engineer - Field Engineer

APPRENTICE RATE SCHEDULE

INTERVAL	PERIOD AND RATES									
Yearly	70%	75%	of Rod/	Chainman	Wage					
Yearly			80%	90%	Transit/	Instrument	man	Wage		

Ratio of Apprentices to Journeymen - *

* No more than 1 Field Engineer Apprentice per Survey Crew.

Craft: Operating Engineer - Field Engineer

COMMENTS/NOTES

Operating Engineer - Field Engineer rates are located in the "Statewide" rate package.

**NEW JERSEY DEPARTMENT OF LABOR AND WORKFORCE DEVELOPMENT
PREVAILING WAGE RATE DETERMINATION**

County - UNION

Craft: Painter - Bridges

PREVAILING WAGE RATE

	05/01/16	05/01/17
Foreman	W57.38 B26.92 T84.30	W61.13 B25.67 T86.80
General Foreman	W59.38 B26.92 T86.30	W63.13 B25.67 T88.80
Journeyman	W52.38 B26.92 T79.30	W56.13 B25.67 T81.80

Craft: Painter - Bridges

APPRENTICE RATE SCHEDULE

INTERVAL	PERIOD AND RATES									
	40%	50%			60%	70%		80%	90%	
6 Months										
Benefits	Intervals	1 to 2 =	8.88	Intervals	3 to 4 =	10.81	Intervals	5 to 6 =	13.48	

Ratio of Apprentices to Journeymen - 1:4

Craft: Painter - Bridges

COMMENTS/NOTES

These rates apply to: All bridges that span waterways, roadways, railways and canyons. All tunnels, overpasses, viaducts and all appurtenances.

FOREMEN REQUIREMENTS:

- When there are 4 or more Painters on a job, 1 shall be designated a Foreman.
- When there are 15 or more Painters on a job, 1 shall be designated a General Foreman.

The regular workday shall consist of 8 hours between 7:00 AM and 5:30 PM.

SHIFT DIFFERENTIALS:

- The second shift shall receive an additional 10% of the hourly rate, per hour, and the third shift shall receive an additional 15% of the hourly rate, per hour.

OVERTIME:

- Hours in excess of 8 per day, Monday through Friday, and all hours on Saturdays and Sundays shall be paid at time and one-half the regular rate. All hours on holidays shall be paid at double the regular rate.
- Saturday or Sunday may be used to make up a day lost to inclement weather, at straight time.
- Four 10-hour days may be worked, at straight time, Monday through Friday.

RECOGNIZED HOLIDAYS: New Year's Day, President's Day, Memorial Day, July 4th, Labor Day, Presidential Election Day, Veterans' Day, Thanksgiving Day, Christmas Day. Saturday holiday observed the preceding Friday. Sunday holiday observed the following Monday.

**NEW JERSEY DEPARTMENT OF LABOR AND WORKFORCE DEVELOPMENT
PREVAILING WAGE RATE DETERMINATION**

County - UNION

Craft: Painter - Line Striping

PREVAILING WAGE RATE

	12/29/16
Apprentice (1st year)	W24.45 B10.75 T35.20
Apprentice (2nd year)	W28.45 B16.80 T45.25
Foreman (Charge Person)	W36.60 B17.08 T53.68
Journeyman 1 (at least 1 year of working exp. as a journeyman)	W32.33 B17.08 T49.41
Journeyman 2 (at least 2 years of working exp. as a journeyman)	W36.10 B17.08 T53.18

Craft: Painter - Line Striping

COMMENTS/NOTES

OVERTIME:

Hours in excess of 8 per day, Monday through Saturday, and all hours on Sundays and holidays shall be paid at time and one-half the hourly rate.

RECOGNIZED HOLIDAYS: New Year's Day, Presidents' Day, Memorial Day, July 4th, Labor Day, Veterans Day, Thanksgiving Day and Christmas Day. Veterans Day may be substituted for the day after Thanksgiving.

**NEW JERSEY DEPARTMENT OF LABOR AND WORKFORCE DEVELOPMENT
PREVAILING WAGE RATE DETERMINATION**

County - UNION

Craft: Painter - New Construction

PREVAILING WAGE RATE

	05/01/16	05/01/17
Foreman	W42.26 B22.94 T65.20	W44.39 B22.35 T66.74
General Foreman	W46.10 B23.40 T69.50	W48.43 B22.81 T71.24
Journeyman	W38.42 B22.49 T60.91	W40.36 B21.90 T62.26

Craft: Painter - New Construction

APPRENTICE RATE SCHEDULE

INTERVAL	PERIOD AND RATES									
4 Months	30%	40%	50%	60%	70%	75%	80%	85%	90%	
Benefits	Intervals	1 to 3 =	8.00	Intervals	4 to 6 =	10.00	Intervals	7 to 9 =	11.00	

Ratio of Apprentices to Journeymen - 1:4

Craft: Painter - New Construction

COMMENTS/NOTES

APPRENTICE RATE SCHEDULE FOR THOSE APPRENTICES ENTERING PROGRAM ON 5-1-14:

INTERVAL	PERIOD AND RATES							
6 Months	40%	45%	55%	65%	70%	75%	80%	90%
Benefits	8.00	8.00	10.00	10.00	11.00	11.00	14.00	14.00

Spraying, sandblasting, lead abatement, work on tanks or stacks, work performed above 3 stories or 30 feet in height, or using swing scaffolds requires an additional 10% of the wage rate.

FOREMEN REQUIREMENTS:

- When there are 4 or more Painters on a job, 1 shall be designated a Foreman.
- When there are 15 or more Painters on a job, 1 shall be designated a General Foreman.

The regular workday shall consist of 8 hours between 7:00 AM and 5:30 PM.

SHIFT DIFFERENTIALS:

- The second shift shall receive an additional 10% of the hourly rate, per hour, and the third shift shall receive an additional 15% of the hourly rate, per hour.

OVERTIME:

- Hours in excess of 8 per day, or before or after the regular workday, Monday through Friday, and all hours on Saturdays shall be paid at time and one-half the regular rate. All hours on Sundays and holidays shall be paid at double the regular rate.

**NEW JERSEY DEPARTMENT OF LABOR AND WORKFORCE DEVELOPMENT
PREVAILING WAGE RATE DETERMINATION**

County - UNION

- Saturday or Sunday may be used to make up a day lost to inclement weather, at straight time.
- Four 10-hour days may be worked, at straight time, Monday through Friday.

RECOGNIZED HOLIDAYS: New Year's Day, President's Day, Memorial Day, July 4th, Labor Day, General Election Day, Veterans' Day, Thanksgiving Day, Christmas Day.

**NEW JERSEY DEPARTMENT OF LABOR AND WORKFORCE DEVELOPMENT
PREVAILING WAGE RATE DETERMINATION**

County - UNION

Craft: Painter - Repainting

PREVAILING WAGE RATE

	05/01/16	05/01/17
Foreman	W31.59 B18.45 T50.04	W34.17 B18.45 T52.62
General Foreman	W34.45 B18.87 T53.32	W37.39 B18.45 T55.84
Journeyman	W28.74 B18.87 T47.61	W31.16 B18.45 T49.61

Craft: Painter - Repainting

APPRENTICE RATE SCHEDULE

INTERVAL	PERIOD AND RATES									
	SEE	PAINTER	NEW	CONSTR UC	TION					

Ratio of Apprentices to Journeymen - 1:4

Craft: Painter - Repainting

COMMENTS/NOTES

NOTE: These rates may only be used on jobs where no major alterations occur, and where not more than 3 other trades are present on the job, but may NOT, under any circumstances, be used for work on bridges, stacks, elevated tank, or generating stations.

Spraying, sandblasting, lead abatement, work on tanks or stacks, work performed above 3 stories or 30 feet in height, or using swing scaffolds requires an additional 10% of the wage rate.

FOREMEN REQUIREMENTS:

- When there are 4 or more Painters on a job, 1 shall be designated a Foreman.
- When there are 15 or more Painters on a job, 1 shall be designated a General Foreman.

OVERTIME:

- Hours in excess of 8 per day and 40 per week shall be paid at time and one-half the regular rate. All hours on Sundays and holidays shall be paid at double the regular rate.
- Four 10-hour days may be worked, at straight time, Monday through Sunday.

RECOGNIZED HOLIDAYS: New Year's Day, President's Day, Memorial Day, July 4th, Labor Day, General Election Day, Veterans' Day, Thanksgiving Day, Christmas Day.

**NEW JERSEY DEPARTMENT OF LABOR AND WORKFORCE DEVELOPMENT
PREVAILING WAGE RATE DETERMINATION**

County - UNION

Craft: Painter- Containment

PREVAILING WAGE RATE

	05/01/16	05/01/17
Journeyman	W33.43 B23.92 T57.35	W37.68 B22.92 T60.60

Craft: Painter- Containment

COMMENTS/NOTES

NOTE: These rates shall require no painting, but used in a supporting capacity only, such as wrapping, boxing, fencing, etc. on tanks.

The regular workday shall consist of 8 hours between 7:00 AM and 5:30 PM.

SHIFT DIFFERENTIALS:

- The second shift shall receive an additional 10% of the hourly rate, per hour, and the third shift shall receive an additional 15% of the hourly rate, per hour.

OVERTIME:

- Hours in excess of 8 per day, Monday through Friday, and all hours on Saturdays and Sundays shall be paid at time and one-half the regular rate. All hours on holidays shall be paid at double the regular rate..

- Four 10-hour days may be worked, at straight time, Monday through Friday.

RECOGNIZED HOLIDAYS: New Year's Day President's Day, Memorial Day, July 4th, Labor Day, Presidential Election Day, Veterans' Day, Thanksgiving Day, Christmas Day. Saturday holiday observed the preceding Friday. Sunday holiday observed the following Monday.

**NEW JERSEY DEPARTMENT OF LABOR AND WORKFORCE DEVELOPMENT
PREVAILING WAGE RATE DETERMINATION**

County - UNION

Craft: Painter-Elevated Water Tanks

PREVAILING WAGE RATE

	05/01/16	05/01/17
Foreman	W47.17 B24.17 T71.34	W50.92 B22.92 T73.84
General Foreman	W49.17 B24.17 T73.34	W52.92 B22.92 T75.84
Journeyman	W42.17 B24.17 T66.34	W45.92 B22.92 T68.84

Craft: Painter-Elevated Water Tanks

APPRENTICE RATE SCHEDULE

INTERVAL	PERIOD AND RATES									
	SEE	PAINTER	BRIDGES							

Craft: Painter-Elevated Water Tanks

COMMENTS/NOTES

These rates apply to: All new and repaint elevated water tanks (interior and exterior).

FOREMEN REQUIREMENTS:

- When there are 4 or more Painters on a job, 1 shall be designated a Foreman.
- When there are 15 or more Painters on a job, 1 shall be designated a General Foreman.

The regular workday shall consist of 8 hours between 7:00 AM and 5:30 PM.

SHIFT DIFFERENTIALS:

- The second shift shall receive an additional 10% of the hourly rate, per hour, and the third shift shall receive an additional 15% of the hourly rate, per hour.

OVERTIME:

- Hours in excess of 8 per day, Monday through Friday, and all hours on Saturdays and Sundays shall be paid at time and one-half the regular rate. All hours on holidays shall be paid at double the regular rate.
- Saturday or Sunday may be used to make up a day lost to inclement weather, at straight time.
- Four 10-hour days may be worked, at straight time, Monday through Friday.

RECOGNIZED HOLIDAYS: New Year's Day, President's Day, Memorial Day, July 4th, Labor Day, Presidential Election Day, Veterans' Day, Thanksgiving Day, Christmas Day. Saturday holiday observed the preceding Friday. Sunday holiday observed the following Monday.

**NEW JERSEY DEPARTMENT OF LABOR AND WORKFORCE DEVELOPMENT
PREVAILING WAGE RATE DETERMINATION**

County - UNION

Craft: Painter-Structural Steel

PREVAILING WAGE RATE

	05/01/16	05/01/17
Foreman	W46.12 B24.51 T70.63	W49.87 B23.26 T73.13
General Foreman	W48.12 B24.51 T72.63	W51.87 B23.26 T75.13
Journeyman	W41.12 B24.51 T65.63	W44.87 B23.26 T68.13

Craft: Painter-Structural Steel

APPRENTICE RATE SCHEDULE

INTERVAL	PERIOD AND RATES									
	SEE	PAINTER	BRIDGES							

Craft: Painter-Structural Steel

COMMENTS/NOTES

These rates apply to: All work in power plants (any aspect). On steeples, on dams, on hangers, transformers, substations, etc. and on open steel, whether new or repaint. All new work (excluding traditional commercial painting work) in refineries, tank farms, water/sewerage treatment facilities and on pipelines.

FOREMEN REQUIREMENTS:

- When there are 4 or more Painters on a job, 1 shall be designated a Foreman.
- When there are 15 or more Painters on a job, 1 shall be designated a General Foreman.

The regular workday shall consist of 8 hours between 7:00 AM and 5:30 PM.

SHIFT DIFFERENTIALS:

- The second shift shall receive an additional 10% of the hourly rate, per hour, and the third shift shall receive an additional 15% of the hourly rate, per hour.

OVERTIME:

- Hours in excess of 8 per day, Monday through Friday, and all hours on Saturdays and Sundays shall be paid at time and one-half the regular rate. All hours on holidays shall be paid at double the regular rate.
- Saturday or Sunday may be used to make up a day lost to inclement weather, at straight time.
- Four 10-hour days may be worked, at straight time, Monday through Friday.

RECOGNIZED HOLIDAYS: New Year's Day, President's Day, Memorial Day, July 4th, Labor Day, Presidential Election Day, Veterans' Day, Thanksgiving Day, Christmas Day. Saturday holiday observed the preceding Friday. Sunday holiday observed the following Monday.

**NEW JERSEY DEPARTMENT OF LABOR AND WORKFORCE DEVELOPMENT
PREVAILING WAGE RATE DETERMINATION**

County - UNION

Craft: Paperhanger - New Construction

PREVAILING WAGE RATE

	05/01/16	05/01/17
Foreman	W43.25 B22.59 T65.84	W45.32 B21.44 T66.76
Journeyman	W39.32 B22.59 T61.91	W41.20 B22.01 T63.21

Craft: Paperhanger - New Construction

APPRENTICE RATE SCHEDULE

INTERVAL	PERIOD AND RATES									
4 Months	30%	40%	50%	60%	70%	75%	80%	85%	90%	
Benefits	Intervals	1 to 3 =	8.00	Intervals	4 to 6 =	10.00	Intervals	7 to 9 =	11.00	

Ratio of Apprentices to Journeymen - 1:4

Craft: Paperhanger - New Construction

COMMENTS/NOTES

APPRENTICE RATE SCHEDULE FOR THOSE APPRENTICES ENTERING PROGRAM ON 5-1-14:

INTERVAL	PERIOD AND RATES								
6 Months	40%	45%	55%	65%	70%	75%	80%	90%	
Benefits	8.00	8.00	10.00	10.00	11.00	11.00	14.00	14.00	

FOREMEN REQUIREMENTS:

- When there are 4 or more Paperhangers on a job, 1 shall be designated a Foreman.

The regular workday shall consist of 8 hours between 7:00 AM and 5:30 PM.

SHIFT DIFFERENTIALS:

- The second shift shall receive an additional 10% of the hourly rate, per hour, and the third shift shall receive an additional 15% of the hourly rate, per hour.

OVERTIME:

- Hours in excess of 8 per day, Monday through Friday, and all hours on Saturdays shall be paid at time and one-half the regular rate. All hours on Sundays and holidays shall be paid at double the regular rate.
- Saturday or Sunday may be used to make up a day lost to inclement weather, at straight time.
- Four 10-hour days may be worked, at straight time, Monday through Friday.

RECOGNIZED HOLIDAYS: New Year's Day, President's Day, Memorial Day, July 4th, Labor Day, General Election Day, Veterans' Day, Thanksgiving Day, Christmas Day.

**NEW JERSEY DEPARTMENT OF LABOR AND WORKFORCE DEVELOPMENT
PREVAILING WAGE RATE DETERMINATION**

County - UNION

Craft: Paperhanger - Renovation

PREVAILING WAGE RATE

	05/01/16	05/01/17
Foreman	W32.39 B18.96 T51.35	W35.06 B18.53 T53.59
Journeyman	W29.45 B18.96 T48.41	W31.88 B18.53 T50.41

Craft: Paperhanger - Renovation

APPRENTICE RATE SCHEDULE

INTERVAL	PERIOD AND RATES									
	SEE	PAPER-	HANGER	NEW	CONSTR	TION				
					UC					

Ratio of Apprentices to Journeymen - 1:4

Craft: Paperhanger - Renovation

COMMENTS/NOTES

NOTE: These rates may only be used on jobs where no major alterations occur, and where not more than 3 other trades are present on the job, but may NOT, under any circumstances, be used for work on bridges, stacks, elevated tanks, or generating stations.

FOREMEN REQUIREMENTS:

- When there are 4 or more Paperhangers on a job, 1 shall be designated a Foreman.

OVERTIME:

- Hours in excess of 8 per day and 40 per week shall be paid at time and one-half the regular rate.

- Four 10-hour days may be worked, at straight time, Monday through Sunday.

**NEW JERSEY DEPARTMENT OF LABOR AND WORKFORCE DEVELOPMENT
PREVAILING WAGE RATE DETERMINATION**

County - UNION

ANY new construction.

RECOGNIZED HOLIDAYS: New Year's Day, Presidents' Day, Memorial Day, July 4th, Labor Day, Presidential Election Day, Veterans' Day, Thanksgiving Day, Christmas Day. Sunday holidays are observed the following Monday.

**NEW JERSEY DEPARTMENT OF LABOR AND WORKFORCE DEVELOPMENT
PREVAILING WAGE RATE DETERMINATION**

County - UNION

Craft: Plasterer

PREVAILING WAGE RATE

See Bricklayer, Stone Mason Rates

Craft: Plasterer

COMMENTS/NOTES

See BRICKLAYER, STONE MASON Rates

**NEW JERSEY DEPARTMENT OF LABOR AND WORKFORCE DEVELOPMENT
PREVAILING WAGE RATE DETERMINATION**

County - UNION

Craft: Plumber PREVAILING WAGE RATE

	05/04/16
Foreman	W55.52 B32.99 T88.51
General Foreman	W59.12 B32.99 T92.11
Journeyman	W51.41 B32.99 T84.40

Craft: Plumber APPRENTICE RATE SCHEDULE

INTERVAL	PERIOD AND RATES									
Yearly	30%	45%	55%	65%	75%					
Benefits	12.77	18.77	20.44	22.13	23.80					

Ratio of Apprentices to Journeymen - *

* Employers may employ 1 apprentice on any job where 1 or 2 journeymen are employed. Thereafter, 1 apprentice may be employed for every 4 journeymen.

Craft: Plumber COMMENTS/NOTES

FOREMAN REQUIREMENTS:

- On any job having 2 or more Plumbers, 1 must be designated a Foreman.
- On any job having 9 or more Plumbers, 2 shall be designated as Foremen.

The regular workday shall consist of 8 hours between 7:00 AM and 4:30 PM.

SHIFT DIFFERENTIALS:

- Shift work must continue for a minimum of 5 consecutive workdays.
- When two shifts are worked, the second shift shall work 7.5 hours and receive 8 hours pay, at a rate equal to the hourly rate plus 10%, inclusive of benefits.
- When a third shift is worked, the third shift shall work 7 hours and receive 8 hours pay, at a rate equal to the hourly rate plus 15%, inclusive of benefits.

OVERTIME:

- All hours in excess of 8 per day, or before or after the regular workday that are not shift work, Monday through Friday, and all hours on Saturday, shall be paid at time and one-half the regular rate, inclusive of benefits. All hours on Sunday and holidays, shall be paid at double the hourly rate, inclusive of benefits.
- Four 10-hour days may be worked, Monday to Thursday, at straight time. Friday may be used as a make-up day for a day lost due to inclement weather. If Friday is not a make-up day, all hours on Friday shall be paid at time and one-half, inclusive of benefits.

RECOGNIZED HOLIDAYS: New Year's Day, Presidents' Day, Memorial Day, July 4th, Labor Day, Presidential Election Day, Veterans' Day, Thanksgiving Day, Christmas Day. Sunday holidays will be observed the following Monday.

**NEW JERSEY DEPARTMENT OF LABOR AND WORKFORCE DEVELOPMENT
PREVAILING WAGE RATE DETERMINATION**

County - UNION

Craft: Roofer PREVAILING WAGE RATE

	06/06/16
Foreman	W36.52 B25.03 T61.55
Journeyman	W35.52 B25.03 T60.55

Craft: Roofer APPRENTICE RATE SCHEDULE

INTERVAL	PERIOD AND RATES									
6 Months	14.21	17.76	21.31	24.86	28.42	31.97				
Benefits	2.10	2.10	22.28	22.28	22.28	22.28				

Ratio of Apprentices to Journeymen - *

- * A) For roofing jobs that are of the 1 or single ply nature: 1:2 or fraction thereof
- B) For roofing jobs on new built up roofs: 1:3 or fraction thereof
- C) For roofing jobs that are of a tear-off nature: 1:2 or fraction thereof
- D) For roofing jobs {not requiring complete removal of existing systems, installation done over existing roof}: 1:3 or fraction thereof

Craft: Roofer COMMENTS/NOTES

Pitch: +.50 per hour

Mop Man: +.30 per hour

The regular workday consists of 8 hours between 8:00 AM and 4:30 PM.

OVERTIME:

Hours in excess of 8 per day, or before or after the regular workday, Monday through Friday, and all hours on Saturdays, Sundays, and holidays shall be paid at time and one-half the regular rate.

RECOGNIZED HOLIDAYS: New Year's Day, Good Friday, Memorial Day, July 4th, Labor Day, Presidential Election Day, Veterans' Day, Thanksgiving Day, Christmas Day.

**NEW JERSEY DEPARTMENT OF LABOR AND WORKFORCE DEVELOPMENT
PREVAILING WAGE RATE DETERMINATION**

County - UNION

Craft: Sheet Metal Sign Installation

PREVAILING WAGE RATE

	10/31/16
Foreman	W33.79 B31.82 T65.61
Journeyman	W32.54 B31.82 T64.36

Craft: Sheet Metal Sign Installation

APPRENTICE RATE SCHEDULE

INTERVAL	PERIOD AND RATES									
1000 hours	35%	40%	45%	50%	55%	60%	65%	70%	75%	80%
Benefits	10.28	11.73	13.18	14.65	16.47	17.96	19.44	20.93	22.40	23.89

Ratio of Apprentices to Journeymen - 1:3

Craft: Sheet Metal Sign Installation

COMMENTS/NOTES

FOREMAN REQUIREMENT:

When there are 6 or more Sheet Metal Sign Installers on a job, 1 shall be designated a Foreman.

The regular workday consists of 8 hours, between 7:00 AM and 3:30 PM.

OVERTIME:

Hours before or after the regular workday, Monday through Friday, and all hours worked on Saturday shall be paid at time and one-half the hourly rate. All hours on Sunday and holidays shall be paid at double the hourly rate.

Four(4) 10 hour days may be worked, Monday through Friday, at straight time, for projects lasting at least one week in duration. The fifth day may be used as a make-up day at straight time for a day lost due to inclement weather. However, if the fifth day is not a make-up day, all hours worked will be paid at time and one-half the hourly rate.

RECOGNIZED HOLIDAYS: New Year's Day, Presidents' Day, Good Friday, Memorial Day, July 4th, Labor Day, Veterans' Day, Thanksgiving Day and the day after, Christmas Day. Saturday holidays observed the preceding Friday, Sunday holidays observed the following Monday.

**NEW JERSEY DEPARTMENT OF LABOR AND WORKFORCE DEVELOPMENT
PREVAILING WAGE RATE DETERMINATION**

County - UNION

Craft: Sprinkler Fitter

PREVAILING WAGE RATE

	01/01/17	07/01/17	01/01/18	07/01/18	01/01/19
Foreman	W62.93 B26.12 T89.05	W64.93 B26.12 T91.05	W64.38 B26.67 T91.05	W66.63 B26.67 T93.30	W66.08 B27.22 T93.30
General Foreman	W65.93 B26.12 T92.05	W67.93 B26.12 T94.05	W67.38 B26.67 T94.05	W69.63 B26.67 T96.30	W69.08 B27.22 T96.30
Journeyman	W58.83 B26.12 T84.95	W60.83 B26.12 T86.95	W60.28 B26.67 T86.95	W62.53 B26.67 T89.20	W61.98 B27.22 T89.20

Craft: Sprinkler Fitter

APPRENTICE RATE SCHEDULE

INTERVAL	PERIOD AND RATES									
	9.50	11.25	50%	55%	60%	65%	70%	75%	80%	85%
1000 Hours	9.50	11.25	50%	55%	60%	65%	70%	75%	80%	85%
Benefits	10.67	10.67	21.22	21.22	21.22	21.22	Intervals	7 to 10	Jourymn	Ben.

APPRENTICE RATE SCHEDULE FOR THOSE APPRENTICES REGISTERED AS OF 7-1-13:

INTERVAL	PERIOD AND RATES									
1000 hours	25%	30%	40%	45%	55%	60%	70%	75%	85%	90%
Benefits	10.67	10.67	21.22	21.22	21.22	21.22	Intervals	7 to 10	receive	Journeyman Ben.

Craft: Sprinkler Fitter

COMMENTS/NOTES

The regular workday consists of 8 consecutive hours between 6:00 AM and 4:30 PM.

FOREMAN REQUIREMENTS:

- The first Sprinkler Fitter on the job must be designated a Foreman.
- On any job having 12 or more Sprinkler Fitters, one must be designated a General Foreman.

SHIFT DIFFERENTIALS:

- Shift work must run for a minimum of 2 consecutive workdays.
- 2nd and 3rd shift shall receive an additional 15% of the regular rate, per hour.
- Any "off hours" shift starting at 8:00 PM or later shall receive an additional 25% of the regular rate, per hour.

OVERTIME:

The first 2 hours in excess of 8 per day, after the regular workday that are not shift work, Monday through Friday, shall be paid at time and one-half the regular rate. Hours worked in excess of 10 per day, Monday through Friday, and all hours on Saturday, Sunday and holidays, shall be paid double the regular rate.

Four 10 hour days may be worked, Monday through Thursday, at straight-time.

RECOGNIZED HOLIDAYS: New Year's Day, Presidents' Day, Good Friday, Memorial Day, July 4th, Labor Day, Presidential Election Day, Veterans Day, Thanksgiving Day, Christmas Day.

**NEW JERSEY DEPARTMENT OF LABOR AND WORKFORCE DEVELOPMENT
PREVAILING WAGE RATE DETERMINATION**

County - UNION

Craft: Tile Setter - Ceramic

PREVAILING WAGE RATE

	12/08/16
Finisher	W43.36 B29.09 T72.45
Setter	W56.13 B32.39 T88.52

Craft: Tile Setter - Ceramic

APPRENTICE RATE SCHEDULE

INTERVAL	PERIOD AND RATES									
750 Hours	50%	55%	60%	65%	70%	75%	85%	95%	100%	

Ratio of Apprentices to Journeymen - 1:4

Craft: Tile Setter - Ceramic

COMMENTS/NOTES

OVERTIME:

Hours in excess of 7 per day, and the first 10 hours on Saturdays shall be paid at time and one-half the hourly rate. All hours on Saturdays after 10 hours shall be paid double the hourly rate. All hours on Sundays and holidays shall be paid at double the hourly rate.

RECOGNIZED HOLIDAYS: New Year's Day, Memorial Day, July 4th, Labor Day, Thanksgiving Day, Christmas Day.

**NEW JERSEY DEPARTMENT OF LABOR AND WORKFORCE DEVELOPMENT
PREVAILING WAGE RATE DETERMINATION**

County - UNION

Craft: Tile Setter - Marble

PREVAILING WAGE RATE

	01/01/17	07/01/17	01/01/18
Tile Setter	W57.74 B34.26 T92.00	W58.18 B35.27 T93.45	W58.53 B36.37 T94.90

Craft: Tile Setter - Marble

APPRENTICE RATE SCHEDULE

INTERVAL	PERIOD AND RATES									
750 Hours	50%	55%	65%	70%	75%	85%	90%	95%		

Ratio of Apprentices to Journeymen - 1:4

Craft: Tile Setter - Marble

COMMENTS/NOTES

OVERTIME:

Hours in excess of 7 per day, Monday through Friday, and the first 7 hours on Saturdays shall be paid at time and one-half the regular rate, inclusive of benefits. Hours in excess of 7 on Saturdays, and all hours on Sundays and holidays shall be paid at double the regular rate, inclusive of benefits.

RECOGNIZED HOLIDAYS: New Year's Day, Presidents' Day, Good Friday, Memorial Day, July 4th, Labor Day, Columbus Day, Veterans' Day, Thanksgiving Day and the day after, Christmas Day. Sunday holidays observed the following Monday.

**NEW JERSEY DEPARTMENT OF LABOR AND WORKFORCE DEVELOPMENT
PREVAILING WAGE RATE DETERMINATION**

County - UNION

Craft: Tile Setter - Mosaic & Terrazzo

PREVAILING WAGE RATE

	01/01/17
Grinder or Assistant	W50.86 B34.14 T85.00
Mechanic	W52.46 B34.16 T86.62

Craft: Tile Setter - Mosaic & Terrazzo

APPRENTICE RATE SCHEDULE

INTERVAL	PERIOD AND RATES									
750 Hours	50%	55%	65%	70%	75%	85%	90%	95%		

Ratio of Apprentices to Journeymen - 1:5

Craft: Tile Setter - Mosaic & Terrazzo

COMMENTS/NOTES

The regular workday consists of 7 hours, between 8:00 AM and 3:30 PM.

OVERTIME:

- Hours in excess of 7 per day, or before or after the regular workday, Monday through Friday, and all hours on Saturdays shall be paid at time and one-half the hourly rate. All hours on Sundays and holidays shall be paid at double the hourly rate.

RECOGNIZED HOLIDAYS: New Year's Day, Presidents' Day, Good Friday, Monday after Easter, Memorial Day, July 4th, Labor Day, Columbus Day, Veterans' Day, Thanksgiving Day and the day after, Christmas Day. Sunday holidays observed the following Monday.

**NEW JERSEY DEPARTMENT OF LABOR AND WORKFORCE DEVELOPMENT
PREVAILING WAGE RATE DETERMINATION**

County - UNION

Craft: Truck Driver

PREVAILING WAGE RATE

	11/01/16	05/01/17	11/01/17	05/01/18	11/01/18
Bucket, Utility, Pick-up, Fuel Delivery trucks	W36.40 B33.01 T69.41	W36.83 B33.78 T70.61	W36.83 B34.58 T71.41	W37.26 B35.40 T72.66	W37.66 B35.80 T73.46
Dump truck, Asphalt Distributor, Tack Spreader	W36.40 B33.01 T69.41	W36.83 B33.78 T70.61	W36.83 B34.58 T71.41	W37.26 B35.40 T72.66	W37.66 B35.80 T73.46
Euclid-type vehicles (large, off-road equipment)	W36.55 B33.01 T69.56	W36.98 B33.78 T70.76	W36.98 B34.58 T71.56	W37.41 B35.40 T72.81	W37.81 B35.80 T73.61
Helper on Asphalt Distributor truck	W36.40 B33.01 T69.41	W36.83 B33.78 T70.61	W36.83 B34.58 T71.41	W37.26 B35.40 T72.66	W37.66 B35.80 T73.46
Slurry Seal, Seeding/Fertilizing/ Mulching truck	W36.40 B33.01 T69.41	W36.83 B33.78 T70.61	W36.83 B34.58 T71.41	W37.26 B35.40 T72.66	W37.66 B35.80 T73.46
Straight 3-axle truck	W36.45 B33.01 T69.46	W36.88 B33.78 T70.66	W36.88 B34.58 T71.46	W37.31 B35.40 T72.71	W37.71 B35.80 T73.51
Tractor Trailer (all types)	W36.55 B33.01 T69.56	W36.98 B33.78 T70.76	W36.98 B34.58 T71.56	W37.41 B35.40 T72.81	W37.81 B35.80 T73.61
Vacuum or Vac-All truck (entire unit)	W36.40 B33.01 T69.41	W36.83 B33.78 T70.61	W36.83 B34.58 T71.41	W37.26 B35.40 T72.66	W37.66 B35.80 T73.46
Winch Trailer	W36.65 B33.01 T69.66	W37.08 B33.78 T70.86	W37.08 B34.58 T71.66	W37.51 B35.40 T72.91	W37.91 B35.80 T73.71

Craft: Truck Driver

COMMENTS/NOTES

BLENDED RATE:

When a truck driver is performing work on the site and also serving as a material delivery driver, the driver shall be paid a "blended rate" which shall be 80% of the above-listed wage rates, plus the full benefit rate. This rate shall be used when the driver "round robins" for a minimum of 6 hours during the work day.

HAZARDOUS WASTE REMOVAL:

- On hazardous waste removal work on a State designated hazardous waste site where the driver is in direct contact with hazardous materials and when personal protective equipment is required for respiratory, skin, and eye protection, the driver shall receive an additional \$3.00 per hour (with or without protective gear).
- A hazardous waste related certified worker at a designated hazardous waste site who is not working in a zone requiring level A, B or C personal protection shall receive an additional \$1.00 per hour.

TRUCK FOREMAN: \$.75 cents per hour above regular rate. Overtime shall be increased accordingly.

**NEW JERSEY DEPARTMENT OF LABOR AND WORKFORCE DEVELOPMENT
PREVAILING WAGE RATE DETERMINATION**

County - UNION

The regular workday shall be 8 hours, starting between 6:00 AM and 8:00 AM.

SHIFT DIFFERENTIAL:

- Shifts starting at 4:00 PM (2nd Shift): + \$2.50 per hour.
- Shifts starting at 12:00 AM (midnight/3rd Shift): time and one-half the hourly rate.
- Shifts starting at a time other than from 6:00 AM to 8:00 AM, when such hours are mandated by the project owner: + \$2.50 per hour.

OVERTIME:

- Hours in excess of 8 per day, or before or after the regular workday, Monday through Friday, that are not shift work, and all hours on Saturdays shall be paid at time and one-half the hourly rate. All hours on Sundays and holidays shall be paid at double the hourly rate.
- Employees may work four 10-hour days at straight time, Monday through Thursday, with Friday used as a make-up day for a lost day. If Friday is not a make-up day, then all hours on Friday shall be paid at time and one-half the hourly rate.

RECOGNIZED HOLIDAYS: New Year's Day, Presidents' Day, Memorial Day (Decoration Day), July 4th, Labor Day, Presidential Election Day, Veterans' Day, Thanksgiving Day, Christmas Day. Sunday holidays will be observed the following Monday. The day after Thanksgiving may be substituted for Veterans' Day.

**NEW JERSEY DEPARTMENT OF LABOR AND WORKFORCE DEVELOPMENT
PREVAILING WAGE RATE DETERMINATION**

County - UNION

Craft: Truck Driver-Material Delivery Driver

PREVAILING WAGE RATE

	05/01/12
Driver	W22.90 B10.17 T33.07

Craft: Truck Driver-Material Delivery Driver

COMMENTS/NOTES

BLENDED RATE:

When a truck driver is performing work on the site and also serving as a material delivery driver, the driver shall be paid a "blended rate". See the "Truck Driver" craft for the blended rates.

Truck Foreman/Shop Steward: +\$0.25 per hour

SHIFT DIFFERENTIALS:

- 2nd Shift shall receive an additional \$0.50 per hour
- 3rd Shift shall receive time and one-half the hourly rate.

OVERTIME:

- Hours in excess of 8 per day, or before or after the regular workday that are not shift work, Monday through Friday, and all hours on Saturday shall be paid at time and one-half the hourly rate. All hours on Sunday and holidays shall be paid at double the hourly rate.

RECOGNIZED HOLIDAYS: New Year's Day, President's Day, Memorial Day (Decoration Day), July 4th, Labor Day, Presidential Election Day, Veterans' Day, Thanksgiving Day, Christmas Day. Sunday holidays will be observed the following Monday. The day after Thanksgiving may be substituted for Veterans' Day.

**NEW JERSEY DEPARTMENT OF LABOR AND WORKFORCE DEVELOPMENT
PREVAILING WAGE RATE DETERMINATION**

County - UNION

Craft: Welder

PREVAILING WAGE RATE

Welder

Craft: Welder

COMMENTS/NOTES

Welders rate is the same as the craft to which the welding is incidental .

STATEWIDE RATES

OPERATING ENGINEERS **Rates Expiration Date : 06/30/2017**

{For apprentice rates refer to "Operating Engineers" apprentice rates in any county rate package}

The regular workday consists of 8 hours, Monday to Friday, between 6:00 AM and 4:30 PM.

SHIFT DIFFERENTIALS:

- Shift work must run for 5 consecutive workdays.
- When 2 shifts are worked, the second shift shall receive an additional 10% of the regular rate inclusive of benefits, per hour.
- When 3 shifts are worked, the second shift shall receive 8 hours pay for 7.5 hours of work, plus an additional 10% of the regular rate inclusive of benefits, per hour. The third shift shall receive 8 hours pay for 7 hours of work, plus an additional 15% of the regular rate inclusive of benefits, per hour.
- When such hours are mandated by the project owner, a shift that starts between 8:00 PM and midnight and ends by 6:00 AM Saturday, or that starts after 8:00 PM on Sunday, provided there are consecutive hours of work within the shift, shall receive an additional 15% of the regular rate, inclusive of benefits.
- On Highway, Road, Street, and Sewer projects irregular shifts starting between 5:00 PM and 12:00 AM may be worked Monday through Friday, and shall receive an additional 15% of the regular rate, inclusive of benefits. When working with other trades that receive a higher irregular shift rate, the Operating Engineer shall also receive the higher irregular shift rate.

OVERTIME:

- Hours in excess of 8 per day, or outside of the regular workday, Monday through Friday, that are not shift work, and all hours on Saturdays shall be paid at time and one-half the regular rate, inclusive of benefits. All hours on Sundays and holidays shall be paid at double the regular rate, inclusive of benefits.
- Four 10-hour days may be worked, Monday through Thursday, at straight time, with all hours on Friday paid at time and one-half the regular rate, inclusive of benefits.

RECOGNIZED HOLIDAYS: New Year's Day, Presidents' Day, Memorial Day, July 4th, Labor Day, Veterans' Day, Thanksgiving Day, Christmas Day. Sunday holidays observed the following Monday. When all trades on a particular job site agree, the day after Thanksgiving may be substituted for Veteran's Day.

On hazardous waste removal work or asbestos removal work, on a state or federally designated hazardous waste site, where the operating engineer is in direct contact with hazardous material and when personal protective equipment is required for respiratory, skin, and eye protection, the operating engineer shall receive an additional 20% of the hourly wage, per hour.

OPERATING ENGINEERS **Rates Expiration Date : 06/30/2017**

Effective Dates:

02/15/2017

Rate	Fringe	Total
47.63	30.63	78.26

CLASSIFICATIONS:

- A-Frame
- Backhoe (combination)
- Boom Attachment on loaders (Except pipehook)
- Boring & Drilling Machine
- Brush Chopper, Brush Shredder, Tree Shredder
- Bulldozer, finish grade
- Cableway
- Carryall
- Concrete Pump
- Concrete Pumping System (Pumpcrete & similar types)
- Conveyor, 125 feet or longer
- Drill Doctor (Duties include dust collector and maintenance)
- Front End Loader (2 cu. yds. but less than 5 cu. yds.)
- Grader, finish
- Groove Cutting Machine (ride-on type)
- Heater Planer
- Hoist (all types including steam, gas, diesel, electric, air hydraulic, single and double drum, concrete, brick shaft caisson, snorkle roof, and other similar types, Except Chicago-boom type)
- Hydraulic Crane (10 tons & under)
- Hydro-Axe
- Hydro-Blaster
- Jack (screw, air hydraulic, power-operated unit, or console type, Except hand jack or pile load test type)
- Log Skidder

OPERATING ENGINEERS **Rates Expiration Date : 06/30/2017**

Effective Dates:

02/15/2017

Rate	Fringe	Total
47.63	30.63	78.26

CLASSIFICATIONS:

- Pan
- Paver, concrete
- Plate & Frame Filter Press
- Pumpcrete (unit type)
- Pumpcrete, Squeezecrete, or Concrete Pumping machine
(regardless of size)
- Scraper
- Side Boom
- Straddle Carrier (Ross and similar types)
- Vacuum Truck
- Whiphammer
- Winch Truck (hoisting)

OPERATING ENGINEERS **Rates Expiration Date : 06/30/2017**

Effective Dates:

02/15/2017

Rate	Fringe	Total
45.72	30.63	76.35

CLASSIFICATIONS:

- Asphalt Curbing Machine
- Asphalt Plant Engineer
- Asphalt Spreader
- Autograde Curb Trimmer & Sidewalk Shoulder Slipform (CMI & similar types)
- Autograde Curecrete Machine (CMI & similar types)
- Autograde Tube Finisher & Texturing Machine (CMI & similar types)
- Bar Bending Machines (Power)
- Batcher, Batching Plant, & Crusher [On Site]
- Belt Conveyor System
- Boom-Type Skimmer Machine
- Bridge Deck Finisher
- Bulldozer (all sizes)
- Captain (Power Boats)
- Car Dumper (railroad)
- Compressor & Blower unit for loading/unloading of concrete, cement, fly ash, or similar type materials (used independently or truck-mounted)
- Compressor (2 or 3 battery)
- Concrete Breaking Machine
- Concrete Cleaning/Decontamination Machine
- Concrete Finishing Machine
- Concrete Saw or Cutter (ride-on type)
- Concrete Spreader (Hetzl, Rexomatic & similar types)
- Concrete Vibrator

OPERATING ENGINEERS **Rates Expiration Date : 06/30/2017**

Effective Dates:

02/15/2017

Rate	Fringe	Total
45.72	30.63	76.35

CLASSIFICATIONS:

- Conveyors - under 125 feet
- Crane Signalman
- Crushing Machine
- Directional Boring Machine
- Ditching Machine - Small (Ditchwitch, Vermeer or similar types)
- Dope Pot - Mechanical (with or without pump)
- Dumpster
- Elevator
- Fireman
- Fork Lift (Economobile, Lull & similar types)
- Front End Loader (1 cu. yd. and over but less than 2 cu. yds.)
- Generator (2 or 3 battery)
- Giraffe Grinder
- Grader & Motor Patrols
- Grout Pump
- Gunnite Machine (Excluding nozzle)
- Hammer - Vibratory (in conjunction with generator)
- Heavy Equipment Robotics - Operator/Technician
- Hoist (roof, tugger, aerial platform hoist, house car)
- Hopper
- Hopper Doors (power operated)
- Ladder (motorized)
- Laddervator

OPERATING ENGINEERS **Rates Expiration Date : 06/30/2017**

Effective Dates:

02/15/2017

Rate	Fringe	Total
45.72	30.63	76.35

CLASSIFICATIONS:

Locomotive (Dinky-type)

Maintenance Utility Man

Master Environmental Maintenance Technician

Mechanic

Mixer (Except paving mixers)

Pavement Breaker (truck-mounted or small self-propelled
ride-on type)

Pavement Breaker - maintenance of compressor or hydraulic unit

Pipe Bending Machine (power)

Pitch Pump

Plaster Pump (regardless of size)

Post Hole Digger (post pounder, auger)

Roller (black top)

Scale (power)

Seamen Pulverizing Mixer

Shoulder Widener

Silo

Skimmer Machine (boom type)

Steel Cutting Machine (service & maintenance)

Tamrock Drill

Tractor

Transfer Machines

Tug Captains

Tug Master (Power Boats)

OPERATING ENGINEERS **Rates Expiration Date : 06/30/2017**

Effective Dates:

02/15/2017

Rate	Fringe	Total
45.72	30.63	76.35

CLASSIFICATIONS:

Ultra High Pressure Waterjet Cutting Tool System -
Operator/Maintenance Technician

Vacuum Blasting Machine - Operator/Maintenance Technician

Vibrating Plant (used with unloading)

Welder & Repair Mechanic

Effective Dates:

02/15/2017

Rate	Fringe	Total
42.38	30.63	73.01

CLASSIFICATIONS:

Assistant Engineer/Oiler

Driller's Helper

Field Engineer - Transit man or Instrument man

Maintenance Apprentice (Deckhand)

Maintenance Apprentice (Oiler)

Mechanic's Helper

Off Road Back Dump

Effective Dates:

02/15/2017

Rate	Fringe	Total
39.80	30.63	70.43

CLASSIFICATIONS:

Field Engineer - Rodman or Chainman

TERRITORY
ENTIRE STATE

NEW JERSEY DEPARTMENT OF LABOR AND WORKFORCE DEVELOPMENT
PREVAILING WAGE RATE DETERMINATION

OPERATING ENGINEERS Rates Expiration Date : 06/30/2017

Effective Dates:

02/15/2017

Rate	Fringe	Total
49.96	30.63	80.59

CLASSIFICATIONS:

Lead Engineer, Foreman Engineer, Safety Engineer (minimum)

OPERATING ENGINEERS **Rates Expiration Date : 06/30/2017**

Effective Dates:

02/15/2017

Rate	Fringe	Total
49.22	30.63	79.85

CLASSIFICATIONS:

- Autograde Pavement Profiler (CMI & similar types)
- Autograde Pavement Profiler - Recycle Type (CMI & similar types)
- Autograde Placer/Trimmer/Spreader Combination (CMI & similar types)
- Autograde Slipform Paver (CMI & similar types)
- Backhoe (Excavator)
- Central Power Plant
- Concrete Paving Machine
- Draglines
- Drill, Bauer, AMI and similar types
- Drillmaster, Quarrymaster
- Drillmaster/Quarrymaster (down-the-hole drill), rotary drill, self-propelled hydraulic drill, self-powered drill
- Elevator Grader
- Field Engineer-Chief of Party
- Front End Loader (5 cu. yards or larger)
- Gradall
- Grader, Rago
- Helicopter Co-Pilot
- Helicopter Communications Engineer
- Juntann Pile Driver
- Locomotive (large)
- Mucking Machine
- Pavement & Concrete Breaker (Superhammer & Hoe Ram)

OPERATING ENGINEERS **Rates Expiration Date : 06/30/2017**

Effective Dates:

02/15/2017

Rate	Fringe	Total
49.22	30.63	79.85

CLASSIFICATIONS:

Pile Driver

Prentice Truck

Roadway Surface Grinder

Scooper (loader & shovel)

Shovel (Excavator)

Trackhoe (Excavator)

Tree Chopper with boom

Trenching Machine (cable plow)

Tunnel Boring Machine

OPERATING ENGINEERS **Rates Expiration Date : 06/30/2017**

Effective Dates:

02/15/2017

Rate	Fringe	Total
44.09	30.63	74.72

CLASSIFICATIONS:

- Chipper
- Compressor (single)
- Concrete Spreader (small type)
- Conveyor Loader (Except elevator graders)
- Engines, Large Diesel (1620 HP) & Staging Pump
- Farm Tractor
- Fertilizing Equipment (operation & maintenance)
- Fine Grade Machine (small type)
- Form Line Grader (small type)
- Front End Loader (under 1 cubic yard)
- Generator (single)
- Grease, Gas, Fuel, & Oil Supply Trucks
- Heaters (Nelson or other type)
- Lights - portable generating light plant
- Mixer, Concrete (small)
- Mulching Equipment (operation & maintenance)
- Power Broom or Sweeper
- Pump (diesel engine & hydraulic - regardless of power)
- Pump (larger than 2 inch suction, including submersible pumps)
- Road Finishing Machine (small type)
- Roller - grade, fill, or stone base
- Seeding Equipment (operation & maintenance)
- Sprinkler & Water Pump Trucks

OPERATING ENGINEERS **Rates Expiration Date : 06/30/2017**

Effective Dates:

02/15/2017

Rate	Fringe	Total
44.09	30.63	74.72

CLASSIFICATIONS:

Steam Generator or Boiler

Stone Spreader

Tamping Machine (vibrating ride-on type)

Temporary Heating Plant (Nelson or other type, including propane, natural gas, and flow-type units)

Water or Sprinkler Truck

Welding Machine (gas, diesel, or electric convertor, of any type)

Welding System - Multiple (rectifier transformer type)

Wellpoint Systems (including installation by bull gang and maintenance)

Effective Dates:

02/15/2017

Rate	Fringe	Total
51.04	30.63	81.67

CLASSIFICATIONS:

Helicopter Pilot/Engineer

Effective Dates:

02/15/2017

Rate	Fringe	Total
55.72	30.63	86.35

CLASSIFICATIONS:

Cranes, Derricks, Pile Driver (all types), over 100 tons and TOWER CRANE with boom (including jib and/or leads) 140 ft. and over

Effective Dates:

02/15/2017

Rate	Fringe	Total
54.72	30.63	85.35

CLASSIFICATIONS:

Cranes, Derricks, Pile Driver (all types), over 100 tons and TOWER CRANE with boom (including jib and/or leads) from 100 ft. to 139 ft.

OPERATING ENGINEERS **Rates Expiration Date : 06/30/2017**

Effective Dates:

02/15/2017

Rate	Fringe	Total
51.22	30.63	81.85

CLASSIFICATIONS:

Cranes, Derricks, Pile Driver (all types) , under 100 tons with a boom (including jib and/or leads) 140 ft. and over

Effective Dates:

02/15/2017

Rate	Fringe	Total
53.72	30.63	84.35

CLASSIFICATIONS:

Cranes, Derricks, Pile Driver (all types), over 100 tons and TOWER CRANE with a boom (including jib and/or leads) under 100 ft.

Effective Dates:

02/15/2017

Rate	Fringe	Total
50.22	30.63	80.85

CLASSIFICATIONS:

Cranes, Derricks, Pile Driver (all types), under 100 tons with a boom (including jib and/or leads) from 100 ft. to 139 ft.

STRUCTURAL STEEL ERECTION Rates Expiration Date : 06/30/2017

{For apprentice rates refer to "Operating Engineers" apprentice rates in any county rate package}

The regular workday consists of 8 hours, Monday to Friday, between 6:00 AM and 4:30 PM.

SHIFT DIFFERENTIALS:

- Shift work must run for 5 consecutive workdays.
- When 2 shifts are worked, the second shift shall receive an additional 10% of the regular rate inclusive of benefits, per hour.
- When 3 shifts are worked, the second shift shall receive 8 hours pay for 7.5 hours of work, plus an additional 10% of the regular rate inclusive of benefits, per hour. The third shift shall receive 8 hours pay for 7 hours of work, plus an additional 15% of the regular rate inclusive of benefits, per hour.
- When such hours are mandated by the project owner, a shift that starts between 8:00 PM and midnight and ends by 6:00 AM Saturday, or that starts after 8:00 PM on Sunday, provided there are consecutive hours of work within the shift, shall receive an additional 15% of the regular rate, inclusive of benefits.
- On Highway, Road, Street, and Sewer projects irregular shifts starting between 5:00 PM and 12:00 AM may be worked Monday through Friday, and shall receive an additional 15% of the regular rate, inclusive of benefits. When working with other trades that receive a higher irregular shift rate, the Operating Engineer shall also receive the higher irregular shift rate.

OVERTIME:

- Hours in excess of 8 per day, or outside of the regular workday, Monday through Friday, that are not shift work, and all hours on Saturdays shall be paid at time and one-half the regular rate, inclusive of benefits. All hours on Sundays and holidays shall be paid at double the regular rate, inclusive of benefits.
- Four 10-hour days may be worked, Monday through Thursday, at straight time, with all hours on Friday paid at time and one-half the regular rate, inclusive of benefits.

RECOGNIZED HOLIDAYS: New Year's Day, Presidents' Day, Memorial Day, July 4th, Labor Day, Veterans' Day, Thanksgiving Day, Christmas Day. Sunday holidays observed the following Monday. When all trades on a particular job site agree, the day after Thanksgiving may be substituted for Veteran's Day.

On hazardous waste removal work or asbestos removal work, on a state or federally designated hazardous waste site, where the operating engineer is in direct contact with hazardous material and when personal protective equipment is required for respiratory, skin, and eye protection, the operating engineer shall receive an additional 20% of the hourly wage, per hour.

Effective Dates:

02/15/2017

Rate	Fringe	Total
52.85	30.63	83.48

CLASSIFICATIONS:

Helicopter Pilot or Engineer

STRUCTURAL STEEL ERECTION **Rates Expiration Date : 06/30/2017**

Effective Dates:

02/15/2017

Rate	Fringe	Total
48.79	30.63	79.42

CLASSIFICATIONS:

A-Frame

Cherry Picker -10 tons or less (Over 10 tons use crane rate)

Hoist (all types Except Chicago-boom)

Jack (screw, air hydraulic, power-operated unit or console type, Except hand jack or pile load test type)

Side Boom

Straddle Carrier

Effective Dates:

02/15/2017

Rate	Fringe	Total
46.13	30.63	76.76

CLASSIFICATIONS:

Aerial Platform Used On Hoists

Apprentice Engineer/Oiler with Compressor or Welding Machine

Captain (Power Boats)

Compressor (2 or 3 in battery)

Conveyor or Tugger Hoist

Elevator or House Car

Fireman

Forklift

Generator (2 or 3)

Maintenance Utility Man

Tug Master (Power Boats)

Welding Machines, Gas or Electric Converters on any type-2 or 3 in battery including diesels

STRUCTURAL STEEL ERECTION **Rates Expiration Date : 06/30/2017**

Effective Dates:

02/15/2017

Rate	Fringe	Total
44.60	30.63	75.23

CLASSIFICATIONS:

Compressor (Single)

Generators

Welding Machines, Gas, Diesel, Or Electric Converters of any type-single

Welding System, Multiple (Rectifier Transformer Type)

Effective Dates:

02/15/2017

Rate	Fringe	Total
42.84	30.63	73.47

CLASSIFICATIONS:

Assistant Engineer/Oiler

Drillers Helper

Field Engineer - Transit/Instrument Man

Maintenance Apprentice (Deckhand)

Maintenance Apprentice (Oiler)

Effective Dates:

02/15/2017

Rate	Fringe	Total
50.41	30.63	81.04

CLASSIFICATIONS:

Lead Engineer, Foreman Engineer, Safety Engineer (Minimum)

Effective Dates:

02/15/2017

Rate	Fringe	Total
39.80	30.63	70.43

CLASSIFICATIONS:

Field Engineer - Rodman or Chainman

STRUCTURAL STEEL ERECTION **Rates Expiration Date : 06/30/2017**

Effective Dates:

02/15/2017

Rate	Fringe	Total
49.55	30.63	80.18

CLASSIFICATIONS:

Field Engineer-Chief of Party

Effective Dates:

02/15/2017

Rate	Fringe	Total
57.74	30.63	88.37

CLASSIFICATIONS:

Cranes (all cranes, land or floating with booms, including jib, 140 ft. and over, above ground). Derricks (all derricks, land, floating or Chicago Boom type with booms including jib, 140 ft. and over, above ground), and Pile Drivers (all types) over 100 tons and Tower Cranes.

Effective Dates:

02/15/2017

Rate	Fringe	Total
56.08	30.63	86.71

CLASSIFICATIONS:

Cranes (all cranes, land or floating with booms including jib, less than 140 ft. above ground), Derricks (all derricks, land, floating or Chicago Boom type with booms including jib, less than 140 ft. above ground), Pile Drivers (all types), over 100 tons and Tower Crane.

Effective Dates:

02/15/2017

Rate	Fringe	Total
53.24	30.63	83.87

CLASSIFICATIONS:

Cranes (all cranes, land or floating with booms including jib, 140 ft. and over, above ground), Derricks (all derricks, land, floating or Chicago Boom type with booms including jib, 140 ft. and over, above ground), Pile Drivers (all types), under 100 tons.

Effective Dates:

02/15/2017

Rate	Fringe	Total
51.58	30.63	82.21

CLASSIFICATIONS:

Cranes (all cranes, land or floating with booms including jib, less than 140 ft. above ground), Derricks (all derricks, land, floating or Chicago Boom type with booms including jib, less than 140 ft. above ground), Pile Drivers (all types), under 100 tons.

TERRITORY
ENTIRE STATE

NEW JERSEY DEPARTMENT OF LABOR AND WORKFORCE DEVELOPMENT
PREVAILING WAGE RATE DETERMINATION

STRUCTURAL STEEL ERECTION Rates Expiration Date : 06/30/2017

Effective Dates:

02/15/2017

Rate	Fringe	Total
53.24	30.63	83.87

CLASSIFICATIONS:

Helicopter Co-Pilot

Helicopter Communications Engineer

TEST BORING PRELIMINARY TO CONSTRUCTION-SOUTH/WEST **Rates Expiration Date : 06/30/2017**

THESE RATES APPLY IN THE FOLLOWING COUNTIES ONLY:

Atlantic, Burlington, Camden, Cape May, Cumberland, Gloucester, Hunterdon, Mercer, Monmouth, Ocean, Salem, Sussex, Warren

The regular workday consists of 8 hours, Monday to Friday, between 6:00 AM and 4:30 PM.

SHIFT DIFFERENTIALS:

- Shift work must run for 5 consecutive workdays.
- When 2 shifts are worked, the second shift shall receive an additional 10% of the regular rate inclusive of benefits, per hour.
- When 3 shifts are worked, the second shift shall receive 8 hours pay for 7.5 hours of work, plus an additional 10% of the regular rate inclusive of benefits, per hour. The third shift shall receive 8 hours pay for 7 hours of work, plus an additional 15% of the regular rate inclusive of benefits, per hour.
- When such hours are mandated by the project owner, a shift that starts between 8:00 PM and midnight and ends by 6:00 AM Saturday, or that starts after 8:00 PM on Sunday, provided there are consecutive hours of work within the shift, shall receive an additional 15% of the regular rate, inclusive of benefits.
- On Highway, Road, Street, and Sewer projects irregular shifts starting between 5:00 PM and 12:00 AM may be worked Monday through Friday, and shall receive an additional 15% of the regular rate, inclusive of benefits. When working with other trades that receive a higher irregular shift rate, the Operating Engineer shall also receive the higher irregular shift rate.

OVERTIME:

- Hours in excess of 8 per day, or outside of the regular workday, Monday through Friday, that are not shift work, and all hours on Saturdays shall be paid at time and one-half the regular rate, inclusive of benefits. All hours on Sundays and holidays shall be paid at double the regular rate, inclusive of benefits.
- Four 10-hour days may be worked, Monday through Thursday, at straight time, with all hours on Friday paid at time and one-half the regular rate, inclusive of benefits.

RECOGNIZED HOLIDAYS: New Year's Day, Presidents' Day, Memorial Day, July 4th, Labor Day, Veterans' Day, Thanksgiving Day, Christmas Day. Sunday holidays observed the following Monday. When all trades on a particular job site agree, the day after Thanksgiving may be substituted for Veteran's Day.

On hazardous waste removal work or asbestos removal work, on a state or federally designated hazardous waste site, where the operating engineer is in direct contact with hazardous material and when personal protective equipment is required for respiratory, skin, and eye protection, the operating engineer shall receive an additional 20% of the hourly wage, per hour.

Effective Dates:

02/15/2017

Rate	Fringe	Total
49.22	30.63	79.85

CLASSIFICATIONS:

Driller

Effective Dates:

02/15/2017

Rate	Fringe	Total
42.38	30.63	73.01

CLASSIFICATIONS:

Driller's Helper

FREE AIR TUNNEL JOBS **Rates Expiration Date : 08/31/2017**

{For apprentice rates refer to "Heavy & General" apprentice rates in any county rate package}

The regular workday consists of 8 hours, starting at 7:00 AM or 8:00 AM.

SHIFT DIFFERENTIALS:

- Shifts must start at 3:00 PM, 4:00 PM, 12:00 AM, or 1:00 AM, to be considered shift work, except when the project owner mandates special hours of work in the job specifications, in which case those hours may be considered shift work.
- When such hours are mandated by the project owner, a shift that begins before midnight on Friday and ends on Saturday morning, or that begins at or after 8:00 PM on Sunday and ends on Monday morning may be paid at the shift differential rate.
- Shifts shall receive an additional \$2.50 per hour.

OVERTIME:

- Hours in excess of 8 per day, Monday through Friday, or outside of the regular workday that are not shift work, and all hours on Saturdays, shall be paid at time and one-half the hourly rate. All hours on Sundays and holidays shall be paid at double the hourly rate.
- Four 10-hour days may be worked, Monday through Thursday, at straight time, with Friday used as a make-up day for a day lost to inclement weather. If Friday is not a make-up day, all hours on Friday shall be paid at time and one-half the hourly rate.

RECOGNIZED HOLIDAYS: New Year's Day, Presidents' Day, Memorial Day, July 4th, Labor Day, Presidential Election Day, Veterans' Day, Thanksgiving Day, Christmas Day. Sunday holidays observed the following Monday. Veterans Day may be substituted for the day after Thanksgiving. However, in the trading of Veterans Day for the day after Thanksgiving, if overtime is worked on Veterans Day, it shall be paid at double the hourly rate.

Hazardous Waste Work:

- where Level A, B, or C protection is required: + \$3.00/hr
- other Hazardous Waste site: + \$1.00/hr

Effective Dates:

03/01/2017

Rate	Fringe	Total
41.50	29.03	70.53

CLASSIFICATIONS:

Walking Boss & Superintendent

Effective Dates:

03/01/2017

Rate	Fringe	Total
41.20	29.03	70.23

CLASSIFICATIONS:

Heading Foreman, Shaft Foreman, Rod Foreman, Electrician Foreman, Rigging Foreman

FREE AIR TUNNEL JOBS **Rates Expiration Date : 08/31/2017**

Effective Dates:

03/01/2017

Rate	Fringe	Total
40.70	29.03	69.73

CLASSIFICATIONS:

Iron Foreman, Caulking Foreman, Form Foreman, Cement Finishing Foreman, Concrete Foreman, Track Foreman, Cleanup Foreman, Grout Foreman

Effective Dates:

03/01/2017

Rate	Fringe	Total
43.20	29.03	72.23

CLASSIFICATIONS:

Blaster

Effective Dates:

03/01/2017

Rate	Fringe	Total
40.15	29.03	69.18

CLASSIFICATIONS:

Top Labor Foreman

Effective Dates:

03/01/2017

Rate	Fringe	Total
39.80	29.03	68.83

CLASSIFICATIONS:

Skilled Men (including Caulker, Powder Carrier, all other skilled men)

Skilled Men (including Miner, Drill Runner, Iron Man, Conveyor Man, Manitenance Man, Safety Miner, Rigger, Block Layer, Cement Finisher, Tod Man)

Effective Dates:

03/01/2017

Rate	Fringe	Total
39.65	29.03	68.68

CLASSIFICATIONS:

Semi-Skilled Men (including Bell or Signal Man Top or Bottom, Form Worker & Mover, Concrete Worker, Shaft Man, Tunnel Laborer, Caulker's Helper, all other semi-skilled)

Semi-Skilled Men (including Miner's Helper, Chuck Tender, Track Man, Nipper, Brake Man, Derail Man, Cable Man, Hose Man, Gravel Man, Form Man)

TERRITORY
ENTIRE STATE

NEW JERSEY DEPARTMENT OF LABOR AND WORKFORCE DEVELOPMENT
PREVAILING WAGE RATE DETERMINATION

FREE AIR TUNNEL JOBS Rates Expiration Date : 08/31/2017

Effective Dates:

03/01/2017

Rate	Fringe	Total
39.15	29.03	68.18

CLASSIFICATIONS:

All Others (including Powder Watchman, Change House Attendant, Top Laborer)

DRILL FOR GROUND WATER SUPPLY **Rates Expiration Date : 06/30/2017**

The well driller and/or helper may perform all work relative to the construction, finishing, and servicing of wells, pumps and borings for ground water supply. The present methods of well drilling entailing as they do, many diverse job operations calling for drilling, pump discharge, piping, and the operation of various types of related power equipment, shall all be within the job duties and functions of the well driller and/or helper. In the event that an extension of work should occur beyond water well drilling functions, into the field of general construction work, such extension of work would come under the appropriate rates listed elsewhere in this wage determination.

- For Work Hours, Shift Differentials, Overtime Rates, and Recognized Holidays see the "Operating Engineers" section of this wage determination.

Effective Dates:

02/15/2017

Rate	Fringe	Total
47.97	30.63	78.60

CLASSIFICATIONS:

Driller

Effective Dates:

02/15/2017

Rate	Fringe	Total
41.13	30.63	71.76

CLASSIFICATIONS:

Driller's Helper

OPERATING ENGINEERS MARINE-DREDGING **Rates Expiration Date : 09/30/2018**

NOTE: Boat crews carrying explosive material (dynamite, pourfex, and other similar materials) shall be paid at 120% of the hourly wage rate for hours engaged in handling of said materials. Employees required to possess a Hazardous Material Certification as a condition of employment shall be compensated at 120% of the hourly wage rate.

OVERTIME:

Hours in excess of 40 per week, and all hours on Saturdays and Sundays, shall be paid at time and one-half the hourly rate. All hours on holidays shall be paid at double the hourly rate.

RECOGNIZED HOLIDAYS: New Year's Day, Martin Luther King Day, Good Friday, Memorial Day, July 4th, Labor Day, Veterans' Day, Thanksgiving Day, Christmas Day. Sunday holidays observed the following Monday.

Effective Dates:

10/01/2016			10/01/2017
Rate	Fringe	Total	Total
37.25	13.78	51.03	52.51

CLASSIFICATIONS:

Lead Dredgerman, Operator, Leverman

Licensed Tug Operator (over 1000 HP)

Effective Dates:

10/01/2016			10/01/2017
Rate	Fringe	Total	Total
32.22	13.38	45.60	46.95

CLASSIFICATIONS:

Derrick Operator, Spider/Spill Barge Operator

Engineer, Electrician, Chief Welder, Chief Mate

Fill Placer, Operator II

Licensed Boat Operator

Maintenance Engineer

Effective Dates:

10/01/2016			10/01/2017
Rate	Fringe	Total	Total
30.33	13.23	43.56	44.86

CLASSIFICATIONS:

Certified Welder

OPERATING ENGINEERS MARINE-DREDGING **Rates Expiration Date : 09/30/2018**

Effective Dates:

10/01/2016			10/01/2017
Rate	Fringe	Total	Total
29.50	12.86	42.36	43.64

CLASSIFICATIONS:

Mate, Drag Barge Operator, Steward, Assistant Fill Placer

Welder

Effective Dates:

10/01/2016			10/01/2017
Rate	Fringe	Total	Total
28.54	12.78	41.32	42.58

CLASSIFICATIONS:

Boat Operator

Effective Dates:

10/01/2016			10/01/2017
Rate	Fringe	Total	Total
23.71	12.10	35.81	36.92

CLASSIFICATIONS:

Shoreman, Deckhand, Rodman, Scowman

MICROSURFACING/SLURRY SEAL Rates Expiration Date : 02/28/2018

THESE RATES APPLY IN THE FOLLOWING COUNTIES ONLY:

Atlantic, Burlington, Camden, Cape May, Cumberland, Gloucester, Mercer, Ocean, Salem

IN ALL OTHER COUNTIES use the Heavy and General Laborers - North "Slurry Seal Laborer" rates.

SHIFT DIFFERENTIALS:

Any shift starting at 3:30 PM or later shall receive an additional \$0.35/hr

OVERTIME:

Hours in excess of 8 per day or 40 per week shall be paid at time and one-half the hourly rate. All hours on holidays shall be paid at double the hourly rate.

RECOGNIZED HOLIDAYS: New Year's Day, Washington's Birthday, Memorial Day, July 4th, Labor Day, Presidential Election Day, Veterans' Day, Thanksgiving Day, Christmas Day.

Effective Dates:

03/01/2017

Rate	Fringe	Total
36.50	21.27	57.77

CLASSIFICATIONS:

Foreman

Effective Dates:

03/01/2017

Rate	Fringe	Total
33.80	21.27	55.07

CLASSIFICATIONS:

Box man

Effective Dates:

03/01/2017

Rate	Fringe	Total
31.75	21.27	53.02

CLASSIFICATIONS:

Microsurface/Slurry Preparation

Effective Dates:

03/01/2017

Rate	Fringe	Total
31.75	21.27	53.02

CLASSIFICATIONS:

Squeegee man

TERRITORY
ENTIRE STATE

NEW JERSEY DEPARTMENT OF LABOR AND WORKFORCE DEVELOPMENT
PREVAILING WAGE RATE DETERMINATION

MICROSURFACING/SLURRY SEAL Rates Expiration Date : 02/28/2018

Effective Dates:

03/01/2017

Rate	Fringe	Total
30.30	21.27	51.57

CLASSIFICATIONS:

Cleaner, Taper

ASPHALT LABORERS - SOUTH Rates Expiration Date : 08/31/2017

"THESE RATES APPLY IN THE FOLLOWING COUNTIES ONLY: Atlantic, Burlington, Camden, Cape May, Cumberland, Gloucester, Mercer, Ocean, Salem

{For apprentice rates refer to "Laborer - Heavy & General" apprentice rates in any county rate package}

The regular workday consists of 8 hours, starting at 7:00 AM or 8:00 AM.

SHIFT DIFFERENTIALS:

- Shifts must start at 3:00 PM, 4:00 PM, 12:00 AM, or 1:00 AM, to be considered shift work, except when the project owner mandates special hours of work in the job specifications, in which case those hours may be considered shift work.
- When such hours are mandated by the project owner, a shift that begins before midnight on Friday and ends on Saturday morning, or that begins at or after 8:00 PM on Sunday and ends on Monday morning may be paid at the shift differential rate.
- Shifts shall receive an additional \$2.50 per hour.

OVERTIME:

- Hours in excess of 8 per day, Monday through Friday, or outside of the regular workday that are not shift work, and all hours on Saturdays, shall be paid at time and one-half the hourly rate. All hours on Sundays and holidays shall be paid at double the hourly rate.
- Four 10-hour days may be worked, Monday through Thursday, at straight time, with Friday used as a make-up day for a day lost to inclement weather. If Friday is not a make-up day, all hours on Friday shall be paid at time and one-half the hourly rate.

RECOGNIZED HOLIDAYS: New Year's Day, Presidents' Day, Memorial Day, July 4th, Labor Day, Presidential Election Day, Veterans' Day, Thanksgiving Day, Christmas Day. Sunday holidays observed the following Monday. Veterans Day may be substituted for the day after Thanksgiving. However, in the trading of Veterans Day for the day after Thanksgiving, if overtime is worked on Veterans Day, it shall be paid at double the hourly rate.

Hazardous Waste Work:

- where Level A, B, or C protection is required: + \$3.00/hr
- other Hazardous Waste site: + \$1.00/hr

Effective Dates:

03/01/2017

Rate	Fringe	Total
41.00	29.03	70.03

CLASSIFICATIONS:

Paving Foreman

Effective Dates:

03/01/2017

Rate	Fringe	Total
39.55	29.03	68.58

CLASSIFICATIONS:

Head Raker

Effective Dates:

03/01/2017

Rate	Fringe	Total
39.40	29.03	68.43

CLASSIFICATIONS:

Raker, Screedman, Luteman

TERRITORY
ENTIRE STATE

NEW JERSEY DEPARTMENT OF LABOR AND WORKFORCE DEVELOPMENT
PREVAILING WAGE RATE DETERMINATION

ASPHALT LABORERS - SOUTH Rates Expiration Date : 08/31/2017

Effective Dates:

03/01/2017

Rate	Fringe	Total
39.15	29.03	68.18

CLASSIFICATIONS:

Tampers, Smoothers, Kettlemen,
Painters, Shovelers, Roller Boys

Effective Dates:

03/01/2017

Rate	Fringe	Total
39.25	29.03	68.28

CLASSIFICATIONS:

Milling Controller

Effective Dates:

03/01/2017

Rate	Fringe	Total
39.45	29.03	68.48

CLASSIFICATIONS:

Traffic Control Coordinator

TEST BORING PRELIMINARY TO CONSTRUCTION-NORTH **Rates Expiration Date : 10/16/2018**

THESE RATES APPLY IN THE FOLLOWING COUNTIES ONLY:
Bergen, Essex, Hudson, Middlesex, Morris, Passaic, Somerset, Union

SHIFT DIFFERENTIAL:

Employees on a shift other than between the hours of 8:00 AM and 5:00 PM shall receive an additional \$1.00 per hour.

OVERTIME:

Hours in excess of 8 per day, Monday through Friday, and all hours on Saturday shall be paid at time and one-half the regular rate. All hours on Sundays and holidays shall be paid at double the regular rate.

RECOGNIZED HOLIDAYS: New Year's Day, Memorial Day, July 4th, Labor Day, Thanksgiving Day, and Christmas Day. Sunday holidays observed the following Monday.

Hazardous Waste Pay (for Levels A, B, and C): an additional 10% of the hourly rate, per hour.

A newly hired Helper with no experience in the industry shall be paid as follows:

- 1st year on the job - 70% of Helper wage rate
- 2nd year on the job - 80% of Helper wage rate
- 3rd year on the job - 90% of Helper wage rate
- All helpers receive full fringe benefit rate.

Effective Dates:

11/01/2016			10/17/2017
Rate	Fringe	Total	Total
30.96	24.76	55.72	57.17

CLASSIFICATIONS:

Helper (4th year helper)

Effective Dates:

11/01/2016			10/17/2017
Rate	Fringe	Total	Total
38.82	24.76	63.58	65.24

CLASSIFICATIONS:

Driller

Effective Dates:

11/01/2016			10/17/2017
Rate	Fringe	Total	Total
44.64	24.76	69.40	71.28

CLASSIFICATIONS:

Foreman

HEAVY & GENERAL LABORERS - NORTH **Rates Expiration Date : 08/31/2017**

THESE RATES APPLY IN THE FOLLOWING COUNTIES ONLY:

Bergen, Essex, Hudson, Hunterdon, Middlesex, Monmouth, Morris, Passaic, Somerset, Sussex, Union, Warren

{For apprentice rates refer to "Laborer - Heavy & General" apprentice rates in any county rate package}

The regular workday consists of 8 hours, starting at 7:00 AM or 8:00 AM.

SHIFT DIFFERENTIALS:

- Shifts must start at 3:00 PM, 4:00 PM, 12:00 AM, or 1:00 AM, to be considered shift work, except when the project owner mandates special hours of work in the job specifications, in which case those hours may be considered shift work.
- When such hours are mandated by the project owner, a shift that begins before midnight on Friday and ends on Saturday morning, or that begins at or after 8:00 PM on Sunday and ends on Monday morning may be paid at the shift differential rate.
- Shifts shall receive an additional \$2.50 per hour.

OVERTIME:

- Hours in excess of 8 per day, Monday through Friday, or outside of the regular workday that are not shift work, and all hours on Saturdays, shall be paid at time and one-half the hourly rate. All hours on Sundays and holidays shall be paid at double the hourly rate.
- Four 10-hour days may be worked, Monday through Thursday, at straight time, with Friday used as a make-up day for a day lost to inclement weather. If Friday is not a make-up day, all hours on Friday shall be paid at time and one-half the hourly rate.

RECOGNIZED HOLIDAYS: New Year's Day, Presidents' Day, Memorial Day, July 4th, Labor Day, Presidential Election Day, Veterans' Day, Thanksgiving Day, Christmas Day. Sunday holidays observed the following Monday. Veterans Day may be substituted for the day after Thanksgiving. However, in the trading of Veterans Day for the day after Thanksgiving, if overtime is worked on Veterans Day, it shall be paid at double the hourly rate.

Hazardous Waste Work:

- where Level A, B, or C protection is required: + \$3.00/hr
- other Hazardous Waste site: + \$1.00/hr

Effective Dates:

03/01/2017

Rate	Fringe	Total
38.75	29.03	67.78

CLASSIFICATIONS:

"D" Rate:

basic, landscape, asphalt, slurry seal, or railroad track laborer; utility meter installer; traffic director/flagman; salamander tender; pitman; dumpman; rakers or tampers on cold patch work; wrappers or coaters of pipe; waterproofer; timberman; wagon drill or drill master helper; powder carrier; magazine tender; signal man; power buggy operator; tree cutter; operator of basic power tools

Effective Dates:

03/01/2017

Rate	Fringe	Total
39.45	29.03	68.48

CLASSIFICATIONS:

"C" Rate:

pipe layer; laser man; conduit or duct line layer; operator of jack hammer, chipping hammer, pavement breaker, concrete cutter, asphalt cutter, sheet hammer, or walk-behind saw cutter; sandblaster; acetylene cutting or burning; wagon drill, directional drill, or hydraulic drill operator; drill master; core driller; traffic control coordinator; asphalt raker or lute man

HEAVY & GENERAL LABORERS - NORTH **Rates Expiration Date : 08/31/2017**

Effective Dates:

03/01/2017

Rate	Fringe	Total
39.70	29.03	68.73

CLASSIFICATIONS:

"B" Rate:

concrete finisher; setter of brick or stone pavers; stone cutter; form setter; manhole, catch basin, or inlet builder; asphalt screedman; rammer; hardscaping; gunite nozzle man

Effective Dates:

03/01/2017

Rate	Fringe	Total
43.25	29.03	72.28

CLASSIFICATIONS:

"A" Rate:

blaster

Effective Dates:

03/01/2017

Rate	Fringe	Total
41.00	29.03	70.03

CLASSIFICATIONS:

"FOREMAN" Rate:

labor foreman, asphalt foreman, drill foreman, pipe foreman, grade foreman, finisher foreman, concrete foreman

Effective Dates:

03/01/2017

Rate	Fringe	Total
42.00	29.03	71.03

CLASSIFICATIONS:

"GENERAL FOREMAN" Rate

HEAVY & GENERAL LABORERS - SOUTH **Rates Expiration Date : 08/31/2017**

THESE RATES APPLY IN THE FOLLOWING COUNTIES ONLY:

Atlantic, Burlington, Camden, Cape May, Cumberland, Gloucester, Mercer, Ocean, Salem

{For apprentice rates refer to "Laborer - Heavy & General" apprentice rates in any county rate package}

The regular workday consists of 8 hours, starting at 7:00 AM or 8:00 AM.

SHIFT DIFFERENTIALS:

- Shifts must start at 3:00 PM, 4:00 PM, 12:00 AM, or 1:00 AM, to be considered shift work, except when the project owner mandates special hours of work in the job specifications, in which case those hours may be considered shift work.
- When such hours are mandated by the project owner, a shift that begins before midnight on Friday and ends on Saturday morning, or that begins at or after 8:00 PM on Sunday and ends on Monday morning may be paid at the shift differential rate.
- Shifts shall receive an additional \$2.50 per hour.

OVERTIME:

- Hours in excess of 8 per day, Monday through Friday, or outside of the regular workday that are not shift work, and all hours on Saturdays, shall be paid at time and one-half the hourly rate. All hours on Sundays and holidays shall be paid at double the hourly rate.
- Four 10-hour days may be worked, Monday through Thursday, at straight time, with Friday used as a make-up day for a day lost to inclement weather. If Friday is not a make-up day, all hours on Friday shall be paid at time and one-half the hourly rate.

RECOGNIZED HOLIDAYS: New Year's Day, Presidents' Day, Memorial Day, July 4th, Labor Day, Presidential Election Day, Veterans' Day, Thanksgiving Day, Christmas Day. Sunday holidays observed the following Monday. Veterans Day may be substituted for the day after Thanksgiving. However, in the trading of Veterans Day for the day after Thanksgiving, if overtime is worked on Veterans Day, it shall be paid at double the hourly rate.

Hazardous Waste Work:

- where Level A, B, or C protection is required: + \$3.00/hr
- other Hazardous Waste site: + \$1.00/hr

Effective Dates:

03/01/2017

Rate	Fringe	Total
38.75	29.03	67.78

CLASSIFICATIONS:

basic, landscape, or railroad track laborer; utility meter installer; traffic director/flagman; salamander tender; pitman; dumpman; rakers or tampers on cold patch work; wrappers or coaters of pipe; waterproofers

tree cutter, timberman

Effective Dates:

03/01/2017

Rate	Fringe	Total
39.45	29.03	68.48

CLASSIFICATIONS:

wagon drill or drill master helper; powder carrier; magazine tender; signal man

HEAVY & GENERAL LABORERS - SOUTH **Rates Expiration Date : 08/31/2017**

Effective Dates:

03/01/2017

Rate	Fringe	Total
39.45	29.03	68.48

CLASSIFICATIONS:

pipe layer; laser man; conduit or duct line layer; operator of jack hammer, chipping hammer, pavement breaker, concrete cutter, asphalt cutter, sheet hammer, or walk-behind saw cutter; sandblaster; acetylene cutting or burning

Effective Dates:

03/01/2017

Rate	Fringe	Total
39.45	29.03	68.48

CLASSIFICATIONS:

wagon or directional drill operator; drill master

Effective Dates:

03/01/2017

Rate	Fringe	Total
43.25	29.03	72.28

CLASSIFICATIONS:

blaster

Effective Dates:

03/01/2017

Rate	Fringe	Total
41.00	29.03	70.03

CLASSIFICATIONS:

labor foreman, drill foreman, pipe foreman, grade foreman, finisher foreman, concrete foreman

Effective Dates:

03/01/2017

Rate	Fringe	Total
42.00	29.03	71.03

CLASSIFICATIONS:

general foreman

TERRITORY
ENTIRE STATE

NEW JERSEY DEPARTMENT OF LABOR AND WORKFORCE DEVELOPMENT
PREVAILING WAGE RATE DETERMINATION

HEAVY & GENERAL LABORERS - SOUTH Rates Expiration Date : 08/31/2017

Effective Dates:

03/01/2017

Rate	Fringe	Total
39.70	29.03	68.73

CLASSIFICATIONS:

concrete finisher; setter of brick or stone pavers; stone cutter; form setter; manhole, catch basin, or inlet builder; rammer; gunite nozzle man

PIPELINE - MAINLINE TRANSMISSION Rates Expiration Date : 06/04/2017

These rates apply to the following: welding on Transportation Mainline pipe lines (cross-country pipe lines, or any segments thereof, transporting coal, gas, oil, water or other transportable materials, vapors or liquids, including portions of such pipe lines within private property boundaries up to the final metering station or connection - the point where a valve, consumer connection, or town border station divides mainline transmission lines or higher pressure lateral and branch lines from lower pressure distribution systems).

PER DIEM PAYMENT:

In addition to the total wage rate paid for each craft, the following per diem (per day) amounts must also be paid - Pipeline Journeyman: \$42.50; Pipeline Journeyman Welder: \$102.50; and Pipeline Helper: \$42.50. Note: in order to receive the per diem payment an employee must work a minimum of 8 hours in a 24 hour period.

NOTES:

- Journeymen employed as "stringer bead" welders and journeymen who are regularly employed as "hot-pass" welders shall receive \$1.00 per hour more than other journeymen.
- Welders running "stringer bead" or "hot-pass" on "cutouts" or "tie-ins" on a production basis shall be paid \$1.00 per hour above the journeymen rate.
- Whenever a welder helper is employed using a power buffer or power grinder immediately behind the stringer bead and/or hot-pass welders, and the pipe gang is set on a production basis, the helper shall be paid \$2.00 per hour above the helper rate.
- If back welding is performed inside a pipe under either or both of the following conditions, the welder engaged in the welding will receive \$3.00 per hour above the regular rate for the job only for the days on which such back welding is performed:
 - The employer elects, as a regular procedure, to back weld each line-up. This condition is not intended to apply to occasional back welding performed by the pipe gang to repair a bead, to rectify a "high-lo" condition or wall thickness, etc.
 - A welder is required to back weld a completed weld behind the firing line.
- If the welder helper is required to go inside the pipe for the purpose of brushing, buffing and grinding the weld, they shall receive a wage rate \$1.00 per hour above the regular helper rate for the days involved.
- Welders working on "hot work" shall be paid \$2.00 per hour above the regular rate for each day engaged in such work. "Hot work" is defined as work on lines in service where there is the danger of fire or explosion.

The regular workday shall be 8 hours, between 8:00 AM and 4:30 PM.

OVERTIME:

Hours in excess of 8 per day, and all hours on Sundays shall be paid at time and one-half the regular rate, inclusive of benefits. All hours on holidays shall be paid at double the regular rate, inclusive of benefits.

RECOGNIZED HOLIDAYS: New Year's Day, July 4th, Labor Day, Thanksgiving Day, and Christmas Day. Sunday holidays observed the following Monday.

Effective Dates:

06/01/2016

Rate	Fringe	Total
54.56	26.59	81.15

CLASSIFICATIONS:

Pipeline Journeyman Welder

TERRITORY
ENTIRE STATE

NEW JERSEY DEPARTMENT OF LABOR AND WORKFORCE DEVELOPMENT
PREVAILING WAGE RATE DETERMINATION

PIPELINE - MAINLINE TRANSMISSION Rates Expiration Date : 06/04/2017

Effective Dates:

06/01/2016

Rate	Fringe	Total
54.56	26.59	81.15

CLASSIFICATIONS:

Pipeline Journeyman

Effective Dates:

06/01/2016

Rate	Fringe	Total
32.99	18.73	51.72

CLASSIFICATIONS:

Pipeline Helper

PIPELINE - GAS DISTRIBUTION **Rates Expiration Date : 10/31/2017**

These rates apply to the following: welding on gas line distribution systems (that portion of the gas distribution system placed in streets, roads, subways, tunnels, viaducts, highways and easements which serves the users of gas).

SHIFT DIFFERENTIALS:

An "irregular" shift may start any time from 5:00 PM to 12:00 AM, Monday through Friday, and shall receive an additional 15% of the regular rate per hour, inclusive of benefits.

OVERTIME:

Hours in excess of forty per week, and all hours on Saturdays shall be paid at time and one-half the regular rate, inclusive of benefits. All hours on Sundays and holidays shall be paid at double the regular rate, inclusive of benefits.

RECOGNIZED HOLIDAYS: New Year's Day, Memorial Day, July 4th, Labor Day, Thanksgiving Day, and Christmas Day. Sunday holidays observed the following Monday.

Effective Dates:

11/01/2016

Rate	Fringe	Total
57.58	21.55	79.13

CLASSIFICATIONS:

Pipeline Journeyman Welder

Effective Dates:

11/01/2016

Rate	Fringe	Total
57.58	21.55	79.13

CLASSIFICATIONS:

Pipeline Journeyman

Effective Dates:

11/01/2016

Rate	Fringe	Total
37.16	15.74	52.90

CLASSIFICATIONS:

Pipeline Helper

ASPHALT LABORERS- NORTH **Rates Expiration Date : 08/31/2017**

THESE RATES APPLY IN THE FOLLOWING COUNTIES ONLY:

Bergen, Essex, Hudson, Hunterdon, Middlesex, Monmouth, Morris, Passaic, Somerset, Sussex, Union, Warren

{For apprentice rates refer to "Laborer - Heavy & General" apprentice rates in any county rate package}

The regular workday consists of 8 hours, starting at 7:00 AM or 8:00 AM.

SHIFT DIFFERENTIALS:

- Shifts must start at 3:00 PM, 4:00 PM, 12:00 AM, or 1:00 AM, to be considered shift work, except when the project owner mandates special hours of work in the job specifications, in which case those hours may be considered shift work.
- When such hours are mandated by the project owner, a shift that begins before midnight on Friday and ends on Saturday morning, or that begins at or after 8:00 PM on Sunday and ends on Monday morning may be paid at the shift differential rate.
- Shifts shall receive an additional \$2.50 per hour.

OVERTIME:

- Hours in excess of 8 per day, Monday through Friday, or outside of the regular workday that are not shift work, and all hours on Saturdays, shall be paid at time and one-half the hourly rate. All hours on Sundays and holidays shall be paid at double the hourly rate.
- Four 10-hour days may be worked, Monday through Thursday, at straight time, with Friday used as a make-up day for a day lost to inclement weather. If Friday is not a make-up day, all hours on Friday shall be paid at time and one-half the hourly rate.

RECOGNIZED HOLIDAYS: New Year's Day, Presidents' Day, Memorial Day, July 4th, Labor Day, Presidential Election Day, Veterans' Day, Thanksgiving Day, Christmas Day. Sunday holidays observed the following Monday. Veterans Day may be substituted for the day after Thanksgiving. However, in the trading of Veterans Day for the day after Thanksgiving, if overtime is worked on Veterans Day, it shall be paid at double the hourly rate.

Hazardous Waste Work:

- where Level A, B, or C protection is required: + \$3.00/hr
- other Hazardous Waste site: + \$1.00/hr

Effective Dates:

03/01/2017

Rate	Fringe	Total
41.00	29.03	70.03

CLASSIFICATIONS:

Asphalt Foreman

Effective Dates:

03/01/2017

Rate	Fringe	Total
39.70	29.03	68.73

CLASSIFICATIONS:

Asphalt Screedman

Effective Dates:

03/01/2017

Rate	Fringe	Total
39.45	29.03	68.48

CLASSIFICATIONS:

Asphalt Raker or Lute Man

TERRITORY
ENTIRE STATE

NEW JERSEY DEPARTMENT OF LABOR AND WORKFORCE DEVELOPMENT
PREVAILING WAGE RATE DETERMINATION

ASPHALT LABORERS- NORTH Rates Expiration Date : 08/31/2017

Effective Dates:

03/01/2017

Rate	Fringe	Total
38.75	29.03	67.78

CLASSIFICATIONS:

Asphalt Laborer

ELECTRICIAN- UTILITY WORK (NORTH) **Rates Expiration Date : 12/03/2017**

Electrician-Utility Work (North)

(For apprentice rates refer to Electrician-Utility Work (North) in any county rate package).

These rates apply to work contracted for by the following utility companies:

Public Service Electric & Gas Co. of NJ, GPU Energy, Borough of Madison Electric Department, Sussex Rural Electric Cooperative, Rockland Utilities, and Butler Municipal Electric Co.

These rates do not apply to work on substations or switching stations.

For Utility work contracted for by a utility company other than those listed above or those listed under "Electrician-Utility Work (South), see the "Outside Commercial Rates" for the county in which the jobsite is located.

* FOR OUTSIDE COMMERCIAL RATES PLEASE SEE COUNTY RATES

The regular workday is 8 hours, between 6:00 AM and 6:00 PM.

FOR EMERGENCY WORK ONLY: (emergency work is defined as work caused by storm, catastrophe, act of god, and circumstances beyond the control of the employer)-all hours of work shall be paid at double the hourly rate.

SHIFT DIFFERENTIALS:

Shift work must run for a minimum of 5 consecutive workdays.

2nd shift (between the hours of 4:30 PM and 1:00 AM): 8 hours of work + 17.3% of the regular rate, inclusive of benefits.

3rd shift (between the hours of 12:30 AM and 9:00 AM): 8 hours of work + 31.4% of the regular rate per hour, inclusive of benefits.

OVERTIME:

Hours in excess of 8 per day, or before or after the regular workday Monday through Friday, that is not shift work, and all hours on Saturday shall be paid at time and one-half the regular rate, inclusive of benefits. All hours on Sundays and holidays shall be paid at double the hourly rate, inclusive of benefits.

Four 10-hour days may worked, at straight time, between 7:00 AM and 6:30 PM, Monday through Thursday.

RECOGNIZED HOLIDAYS:

New Year's Day, Presidents' Day, Memorial Day, July 4th, Labor Day, Presidential Election Day, Veterans' Day, Thanksgiving Day and Christmas Day, or day on which they are legally observed.

Effective Dates:

12/04/2016

Rate	Fringe	Total
52.26	35.01	87.27

CLASSIFICATIONS:

Chief Lineman

Effective Dates:

12/04/2016

Rate	Fringe	Total
49.31	33.03	82.34

CLASSIFICATIONS:

Journeyman Lineman

ELECTRICIAN- UTILITY WORK (NORTH) Rates Expiration Date : 12/03/2017

Effective Dates:

12/04/2016

Rate	Fringe	Total
49.31	33.03	82.34

CLASSIFICATIONS:

Special License Operator

Effective Dates:

12/04/2016

Rate	Fringe	Total
48.81	32.70	81.51

CLASSIFICATIONS:

Transit Man

Effective Dates:

12/04/2016

Rate	Fringe	Total
47.33	31.71	79.04

CLASSIFICATIONS:

Line Equipment Operator

Effective Dates:

12/04/2016

Rate	Fringe	Total
41.42	27.75	69.17

CLASSIFICATIONS:

Dynamite Man

Effective Dates:

12/04/2016

Rate	Fringe	Total
58.18	38.98	97.16

CLASSIFICATIONS:

General Foreman

Effective Dates:

12/04/2016

Rate	Fringe	Total
56.70	37.98	94.68

CLASSIFICATIONS:

Assistant General Foreman

ELECTRICIAN- UTILITY WORK (NORTH) Rates Expiration Date : 12/03/2017

Effective Dates:

12/04/2016

Rate	Fringe	Total
55.22	36.99	92.21

CLASSIFICATIONS:

Line Foreman

Effective Dates:

12/04/2016

Rate	Fringe	Total
39.94	26.75	66.69

CLASSIFICATIONS:

Straight Light Mechanical Leader

Effective Dates:

12/04/2016

Rate	Fringe	Total
37.97	25.43	63.40

CLASSIFICATIONS:

Groundman Winch Operator

Effective Dates:

12/04/2016

Rate	Fringe	Total
37.97	25.43	63.40

CLASSIFICATIONS:

Groundman Truck Operator

Effective Dates:

12/04/2016

Rate	Fringe	Total
37.47	25.10	62.57

CLASSIFICATIONS:

Straight Light Mechanic

Effective Dates:

12/04/2016

Rate	Fringe	Total
37.47	25.10	62.57

CLASSIFICATIONS:

Line Equipment Mechanic

TERRITORY
ENTIRE STATE

NEW JERSEY DEPARTMENT OF LABOR AND WORKFORCE DEVELOPMENT
PREVAILING WAGE RATE DETERMINATION

ELECTRICIAN- UTILITY WORK (NORTH) Rates Expiration Date : 12/03/2017

Effective Dates:

12/04/2016

Rate	Fringe	Total
32.05	21.47	53.52

CLASSIFICATIONS:

Groundman 2nd Year

Effective Dates:

12/04/2016

Rate	Fringe	Total
29.58	19.81	49.39

CLASSIFICATIONS:

Groundman 1st Year

Effective Dates:

12/04/2016

Rate	Fringe	Total
48.81	32.70	81.51

CLASSIFICATIONS:

Line Equipment Foreman

ELECTRICIAN- UTILITY WORK (SOUTH) Rates Expiration Date : 12/02/2017

Electrician-Utility Work (South)

(For apprentice rates refer to Electrician-Utility Work (South) in any county rate package).

These rates apply to work contracted for by the following utility company:

Atlantic City Electric.

These rates do not apply to work on substations or switching stations.

For utility work contracted for by a utility company other than the one listed above or those listed under "Electrician-Utility Work (North), see the "Outside Commercial Rates" for the county in which the jobsite is located.

* FOR OUTSIDE COMMERCIAL RATES PLEASE SEE COUNTY RATES

The regular workday is 8 hours, between 7:00 AM and 4:30 PM.

FOR EMERGENCY WORK ONLY: (emergency work is defined as work caused by storm, catastrophe, act of god, and circumstances beyond the control of the employer)- all hours of work shall be paid at double the hourly rate.

SHIFT DIFFERENTIALS:

Shift work must run for a minimum of 5 consecutive workdays.

When two (2) or three (3) shifts are worked the following shall apply:

1st shift (between the hours of 8:00 AM and 4:30 PM)

2nd shift (between the hours of 4:30 PM and 12:30 AM): 8 hours of work + 10% of the regular rate of pay for 7.5 hours worked.

3rd shift (between the hours of 12:30 AM and 8:00 AM): 8 hours of work + 15% of the regular rate of pay for 7 hours worked.

OVERTIME:

Hours in excess of 8 per day, or before or after the regular workday Monday through Friday, that is not shift work, and all hours on Saturday shall be paid at time and one-half the regular rate. All hours on Sundays and Holidays shall be paid double the hourly rate.

Four 10-hour days may be worked, at straight time, between 6:00 AM and 6:00 PM, Monday through Thursday with Friday used as a make-up day.

RECOGNIZED HOLIDAYS:

New Year's Day, Memorial Day, July 4th, Labor Day, Veterans' Day, Thanksgiving Day and Christmas Day or on days celebrated.

WORKING RULES:

There shall be a Foreman in charge of each work crew. No crews are to exceed twelve (12) men, including Foremen.

There shall be a General Foreman designated for transmission work when three (3) or more crews are on the same job and for distribution work where there are more than twenty (20) employees on site.

A small job crew shall consist of five (5) or less employees, one (1) of the Journeyman Linemen in the crew shall be designated as a Small Job Foreman.

Work performed from ladders and/or mechanical lift equipment shall be the work of Linemen and/or Apprentices.

On new construction, fitting and framing poles, towers or structures may be done by Journeymen and/or Apprentices. Groundmen may assist, but may not perform any work which would be performed by Linemen if assembled in the air.

There shall be a Journeyman Lineman in each pole setting, erection, grounding, wire and cable-pulling crew of more than three (3) men.

Effective Dates:

12/04/2016

Rate	Fringe	Total
58.38	45.19	103.57

CLASSIFICATIONS:

General Foreman

ELECTRICIAN- UTILITY WORK (SOUTH) Rates Expiration Date : 12/02/2017

Effective Dates:

12/04/2016

Rate	Fringe	Total
52.00	41.37	93.37

CLASSIFICATIONS:

Foreman

Effective Dates:

12/04/2016

Rate	Fringe	Total
49.26	39.74	89.00

CLASSIFICATIONS:

Small Job Foreman

Effective Dates:

12/04/2016

Rate	Fringe	Total
45.61	37.54	83.15

CLASSIFICATIONS:

Heavy Equipment Operator

Effective Dates:

12/04/2016

Rate	Fringe	Total
45.61	37.54	83.15

CLASSIFICATIONS:

Cable Splicer

Effective Dates:

12/04/2016

Rate	Fringe	Total
45.61	37.54	83.15

CLASSIFICATIONS:

Journeyman Lineman

Effective Dates:

12/04/2016

Rate	Fringe	Total
45.61	37.54	83.15

CLASSIFICATIONS:

Journeyman Welder

ELECTRICIAN- UTILITY WORK (SOUTH) **Rates Expiration Date : 12/02/2017**

Effective Dates:

12/04/2016

Rate	Fringe	Total
45.61	37.54	83.15

CLASSIFICATIONS:

Journeyman Painter

Effective Dates:

12/04/2016

Rate	Fringe	Total
36.49	32.08	68.57

CLASSIFICATIONS:

Light Equipment Operator

Effective Dates:

12/04/2016

Rate	Fringe	Total
31.93	29.37	61.30

CLASSIFICATIONS:

Groundman Truck Driver

Effective Dates:

12/04/2016

Rate	Fringe	Total
29.65	27.99	57.64

CLASSIFICATIONS:

Groundman 3rd Year

Effective Dates:

12/04/2016

Rate	Fringe	Total
27.37	26.66	54.03

CLASSIFICATIONS:

Groundman 2nd Year

Effective Dates:

12/04/2016

Rate	Fringe	Total
25.09	25.29	50.38

CLASSIFICATIONS:

Groundman 1st Year

TERRITORY
ENTIRE STATE

NEW JERSEY DEPARTMENT OF LABOR AND WORKFORCE DEVELOPMENT
PREVAILING WAGE RATE DETERMINATION

ELECTRICIAN- UTILITY WORK (SOUTH) Rates Expiration Date : 12/02/2017

Effective Dates:

12/04/2016

Rate	Fringe	Total
20.07	22.27	42.34

CLASSIFICATIONS:

Flagman

HEAVY & GENERAL LABORERS- NEW TRANS HUDSON TUNNELS Rates Expiration Date : 08/31/2017

****THESE RATES APPLY TO CONSTRUCTION ON NEW TRANS HUDSON TUNNELS ONLY****

{For apprentice rates refer to "Laborer - Heavy & General" apprentice rates in any county rate package}

The regular workday consists of 8 hours, starting at 7:00 AM or 8:00 AM.

SHIFT DIFFERENTIALS:

- Shifts must start at 3:00 PM, 4:00 PM, 12:00 AM, or 1:00 AM, to be considered shift work, except when the project owner mandates special hours of work in the job specifications, in which case those hours may be considered shift work.
- When such hours are mandated by the project owner, a shift that begins before midnight on Friday and ends on Saturday morning, or that begins at or after 8:00 PM on Sunday and ends on Monday morning may be paid at the shift differential rate.
- Shifts shall receive an additional \$2.50 per hour.

OVERTIME:

- Hours in excess of 8 per day, Monday through Friday, or outside of the regular workday that are not shift work, and all hours on Saturdays, shall be paid at time and one-half the hourly rate. All hours on Sundays and holidays shall be paid at double the hourly rate.
- Four 10-hour days may be worked, Monday through Thursday, at straight time, with Friday used as a make-up day for a day lost to inclement weather. If Friday is not a make-up day, all hours on Friday shall be paid at time and one-half the hourly rate.

RECOGNIZED HOLIDAYS: New Year's Day, Presidents' Day, Memorial Day, July 4th, Labor Day, Presidential Election Day, Veterans' Day, Thanksgiving Day, Christmas Day. Sunday holidays observed the following Monday. Veterans Day may be substituted for the day after Thanksgiving. However, in the trading of Veterans Day for the day after Thanksgiving, if overtime is worked on Veterans Day, it shall be paid at double the hourly rate.

Hazardous Waste Work:

- where Level A, B, or C protection is required: + \$3.00/hr
- other Hazardous Waste site: + \$1.00/hr

Effective Dates:

03/01/2017

Rate	Fringe	Total
62.25	29.03	91.28

CLASSIFICATIONS:

Walking Boss & Superintendent

Effective Dates:

03/01/2017

Rate	Fringe	Total
61.80	29.03	90.83

CLASSIFICATIONS:

Heading Foreman, Shaft Foreman, Rod Foreman, Electrical Foreman, Rigging Foreman

HEAVY & GENERAL LABORERS- NEW TRANS HUDSON TUNNELS **Rates Expiration Date : 08/31/2017**

Effective Dates:

03/01/2017

Rate	Fringe	Total
61.05	29.03	90.08

CLASSIFICATIONS:

Iron Foreman, Caulking Foreman, Form Foreman, Cement Finishing Foreman, Concrete Foreman, Track Foreman, Clean-up Foreman, Grout Foreman

Effective Dates:

03/01/2017

Rate	Fringe	Total
64.80	29.03	93.83

CLASSIFICATIONS:

Blaster

Effective Dates:

03/01/2017

Rate	Fringe	Total
60.23	29.03	89.26

CLASSIFICATIONS:

Top Labor Foreman

Effective Dates:

03/01/2017

Rate	Fringe	Total
59.70	29.03	88.73

CLASSIFICATIONS:

Skilled Men (including Caulker, Powder Carrier, all other skilled men)

Skilled Men (including Miner, Drill Runner, Iron Man, Conveyor Man, Maintenance Man, Safety Miner, Rigger, Block Layer, Cement Finisher, Rod Man)

Effective Dates:

03/01/2017

Rate	Fringe	Total
59.48	29.03	88.51

CLASSIFICATIONS:

Semi-Skilled Men (including Bell or Signal Man top or bottom, Form Worker & Mover, Concrete Worker, Shaft Man, Tunnel Laborer, Caulker's Helper, all other semi-skilled)

Semi-Skilled Men (including Miner's Helper, Chuck Tender, Track Man, Nipper, Brake Man, Derail Man, Cable Man, Hose Man, Gravel Man, Form Man)

TERRITORY
ENTIRE STATE

NEW JERSEY DEPARTMENT OF LABOR AND WORKFORCE DEVELOPMENT
PREVAILING WAGE RATE DETERMINATION

HEAVY & GENERAL LABORERS- NEW TRANS HUDSON TUNNELS Rates Expiration Date : 08/31/2017

Effective Dates:

03/01/2017

Rate	Fringe	Total
58.73	29.03	87.76

CLASSIFICATIONS:

All others (including Powder Watchman, Change House Attendant, Top Laborer, Job Steward)

TECHNICAL SPECIFICATIONS
FOR
INTERSECTION IMPROVEMENTS AT
CHESTNUT STREET (CR 625) AND FIFTH AVENUE
BOROUGH OF ROSELLE, UNION COUNTY, NEW JERSEY

The 2007 New Jersey Department of Transportation Standard Specifications for Road and Bridge Construction shall govern this Contract with all supplemental specifications through 2017.

The following pages are revisions to the listed Sections of the 2007 NJDOT Standard Specifications:

DIVISION 150 - CONTRACT REQUIREMENTS

Section 157 Construction Layout and Monuments
Section 159 Traffic Control

DIVISION 200 - EARTHWORK

Section 201 Clearing Site
Section 202 Excavation

DIVISION 300 - SUBBASE AND BASE COURSES

Section 302 Aggregate Base Course

DIVISION 400 - PAVEMENTS

Section 401 Hot Mix Asphalt (HMA) Courses

DIVISION 600 - MISCELLANEOUS CONSTRUCTION

Section 606 Sidewalks, Driveways and Islands
Section 607 Curbs
Section 610 Traffic Stripes, Traffic Markings and Rumble Strips
Section 612 Signs

DIVISION 700 - ELECTRICAL

Section 701 General Items
Section 702 Traffic Signals

DIVISION 800 - LANDSCAPING

Section 802 Trimming and Removing Trees
Section 804 Topsoiling
Section 806 Fertilizing and Seeding
Section 809 Mulching

The following Sections of the Standard Specifications are deleted:

SECTION 101 – GENERAL INFORMATION
SECTION 102 – BIDDING REQUIREMENTS AND CONDITIONS
SECTION 103 – AWARD AND EXECUTION OF CONTRACT
SECTION 104 – SCOPE OF WORK
SECTION 105 – CONTROL OF WORK
SECTION 106 – CONTROL OF MATERIAL
SECTION 107 – LEGAL RELATIONS AND RESPONSIBILITY TO PUBLIC
SECTION 108 – PROSECUTION AND PROGRESS
SECTION 109 – MEASUREMENT AND PAYMENT

DIVISION 150 – CONTRACT REQUIREMENTS

SECTION 157 – CONSTRUCTION LAYOUT AND MONUMENTS

157.04 MEASUREMENT AND PAYMENT

THE SECTION IS CHANGED TO:

Measurement and Payment will be as follows:

<i>Item</i>	<i>Pay Unit</i>
Construction Layout (Item 1)	Lump Sum

Payment for construction layout will be adjusted based on the final contract amount and will be calculated as follows:

$$CL = \frac{CL_B \times (C_F - E)}{C_O - E}$$

Where:

CL = Adjusted payment for CONSTRUCTION LAYOUT.

CL_B = Bid price for CONSTRUCTION LAYOUT.

C_O = Original Contract Price.

C_F = Final Contract Price.

E = Total cost of payment for CONSTRUCTION LAYOUT, PERFORMANCE BOND AND PAYMENT BOND, Incentive/Disincentives, Bonus/Penalties, and claim settlements.

Should the adjusted price be less than the bid price for construction layout, the contractor shall issue a credit to the County. The adjusted price may not exceed the bid price.

SECTION 159 – TRAFFIC CONTROL

159.01 DESCRIPTION

THE FOLLOWING IS ADDED:

Before beginning work on any phase of the project the Contractor shall furnish and install all specified warning signs, temporary pavement markings, barricades, flashing lights, and other devices necessary, in the opinion of the Union County Engineer, to protect the public during that phase of his operations.

The contractor shall provide and maintain to the satisfaction of the Union County Engineer, adequate and safe means of passage of vehicular and pedestrian traffic at all times throughout the project length. This requirement shall include vehicular (including fire, police and other emergency vehicles and school buses) and pedestrian access to all residences, businesses, schools and public buildings adjoining or affected by the work.

During periods of inactivity all construction equipment, material and other obstructions shall be removed from all travel ways and shoulders, and properly secured from traffic.

All traffic warning signs shall be furnished, erected, and maintained in a suitable manner as determined by the County Engineer and shall be maintained so as to provide maximum visibility and legibility.

Signs, lights, barricades and all other warning and protective devices shall be established, repaired, replaced, relocated and removed by the Contractor at the locations and times and in the manner directed by the Union County Engineer.

159.03 PROCEDURES

THE FOLLOWING IS ADDED:

The Contractor shall be responsible for project maintenance within the project limits until acceptance. This maintenance shall consist of continuous and effective work prosecuted day by day, with adequate equipment and forces to the end that the roadway is kept in satisfactory condition at all times.

It shall be the Contractor's responsibility to maintain driveway access for all adjacent property owners. In the event that the driveway access must be temporarily denied the Contractor shall provide written notice to the Engineer and property owner at least five (5) working days in advance of the driveway closing.

On any section opened to traffic, whether provided for in the contract documents or opened as directed, any damage to the roadway due to the Contractor's operations shall be repaired at no cost to the County of Union.

All equipment, materials, excavated material or debris shall be removed by the end of the workday unless specific arrangements have been made with the County and/or Municipality. Any items left on site must be safely secured and barricaded. Material or debris left at the end of the day by the Contractor on, near or adjacent to the sidewalk or traveled way that is open to pedestrians and vehicles and creates a hazard is subject to removal by County or Municipal personnel. **All costs associated with the removal of any hazards left by the Contractor will be charged to this project and deducted from any monies owed to the Contractor.**

The Contractor shall notify the Engineer of the anticipated start-up and shut down times the day before work is to actually commence. Neither the Contractor nor his forces or equipment shall occupy any part of the roadway or begin work prior to the work zone being properly established (including detours). Work on the project will not be allowed to commence until all provisions of this item are met to the satisfaction of the Engineer. Work that has been performed without meeting these provisions will not be subject to payment.

The Contractor shall be responsible for maintaining safe and adequate pedestrian access in, near or around the work site. Neither the Contractor's equipment nor debris and materials shall occupy any part of the sidewalk, path or traveled way that is not being constructed. Any pedestrian detours or diversions shall be approved by the Engineer and meet the requirements of the American with Disabilities Act (ADA), as amended. Additionally, precautions such as snow fencing or other physical separation between the walkway and work site, and signing shall be erected and maintained by the Contractor.

Prior to beginning a seasonal shutdown or any other prolonged work stoppage or when work is suspended by the Engineer, all excavated areas within the traveled way or adjacent thereto shall be brought to a grade compatible with the existing traveled way or to finished grade, as approved. The Contractor is responsible for maintenance of these temporarily backfilled areas throughout the duration of the shutdown. Should an area require repair the Contractor shall be on site within 24 hours to perform such repair. All maintenance operations shall be performed at no additional cost to the County of Union.

ALL WORKERS SHALL WEAR REFLECTORIZED GARMENTS, UTILIZING 360° VISIBILITY, AS SPECIFIED FOR TRAFFIC DIRECTORS.

The Contractor shall not be responsible for removal of ice or snow from sections of roadways opened to traffic or for damage to the project caused by the operation of snow plows or other snow removal or deicing operations carried on by others under the supervision or direction of the County.

The Contractor shall be responsible for project maintenance within the project limits until acceptance. This maintenance shall consist of continuous and effective work prosecuted day by day, with adequate equipment and forces to the end that the roadway is kept in satisfactory condition at all times

Should the Contractor begin work prior to the work zone being properly established as described herein, the County shall assume no responsibility for tort liability issues arising from the Contractor's premature start. All liability and consequence arising from a premature start is solely the Contractor's.

In the event that the manhole, inlet or other appurtenance is in the middle of a travel way and the placement of a traffic device would impede the flow of traffic, the manhole, inlet or other appurtenance will be ramped with fresh bituminous material (either cold or hot mix). The use of millings to perform this operation will not be allowed. Bituminous material for manhole, inlet and other ramping will not be measured. No separate payment will be made for this bituminous material.

If the Contractor at any time fails to comply with these provisions, the Engineer will immediately notify the Contractor of such noncompliance. If the Contractor fails to remedy unsatisfactory maintenance within one (1) calendar day, after receipt of such notice, the Engineer may proceed to maintain the project and the entire cost of this maintenance will be deducted from any monies due or that may become due the Contractor.

159.03.01 Traffic Control Coordinator

THE FOLLOWING IS ADDED TO THE FIRST PARAGRAPH

The County shall be supplied with the Traffic Control Coordinator's contact telephone number. A pager number for this purpose will not suffice. If and when the number is called, the contractor or duly appointed agent must be available to answer and respond to the emergency

call. The contractor's response time to emergencies that arise during this project shall be within one (1) hour.

THE FOLLOWING IS ADDED AT THE END OF THIS SUB-SECTION:

Traffic Control Plan (TCP). The Contractor shall provide to the Union County Engineer a traffic control plan which complies with MUTCD and which indicates the personnel, signs, traffic directors, traffic cones, drums, lights, equipment and all other incidentals necessary for the safe maintenance and protection of traffic. Said traffic control plan shall be submitted to the Union County Engineer a minimum of two (2) weeks prior to the start of Construction. This traffic control plan shall clearly detail the means and methods to be employed to accommodate the shifting of traffic during the performance of specific tasks as depicted on the progress schedule. The plan shall also indicate the maintenance and protection of traffic measures to be taken at areas to be used for equipment and materials storage. No work shall commence without approval of the plan by the Union County Engineer. Detailed plans as above discussed must show the staging of lane closures, available lane widths and time estimates.

Before beginning construction, the Contractor shall be responsible for providing, placing and installing all signing, channelizing devices, etc., shown on the traffic control plan or as directed by the Engineer. Additionally, all parts of the work zone (i.e., Advance Warning Area, Transition Zones, Buffer Spaces (both lateral and transverse), Work Area and Termination Area, shall be established in accordance with the traffic control plan and maintained accordingly. The County Engineer shall review all installations prior to work to ensure conformance. The Contractor shall not be allowed to alter or modify any part of the traffic control plan without written consent from the County Engineer.

159.03.02 Traffic Control Devices

THE FOLLOWING IS ADDED:

All traffic control devices furnished by the Contractor shall be new, or in acceptable condition as defined by the American Traffic Safety Services Association (ATSSA), **Quality Standards For Work Zone Traffic Control Devices – 3rd Edition**. Traffic control devices damaged under this Contract as a result of carelessness or mishandling by the Contractor (i.e., running over cones or barrels with his equipment or splashing tar on traffic control devices, etc.) shall be replaced within one (1) calendar day. The County reserves the right to reject any traffic control device, which in their sole opinion does not satisfy the criteria of these Specifications, is damaged or otherwise incapable of providing the function for which it was intended. In this event, the Contractor shall replace the deficient traffic control devices and/or materials within one (1) calendar day. Upon completion of the Project, all traffic control devices and materials furnished by the Contractor shall be removed by the Contractor.

At any time during the course of the project, 75 percent of all traffic control devices shall be in acceptable condition, as outlined in the aforementioned pamphlet.

Devices not meeting these criteria shall not be used on the project and are not eligible for reimbursement. Any devices damaged during the course of the project, shall be replaced at the direction of the Engineer, without additional compensation. Therefore, the Contractor is

expected to maintain an adequate supply of the various types of traffic control devices used on this project.

The Contractor shall be responsible for erecting advance notice of construction signs on all roadways approaching the work site. Sign sizes and legends will be provided by the Engineer prior to the pre-construction meeting.

“CONSTRUCTION TO BEGIN ON OR ABOUT...” advance notice of construction signs shall be erected no less than five (5) business days prior to the start of work. One sign shall be placed on each approach roadway within 200 feet of the intersection or as directed by the Engineer.

All construction signs shall be fabricated from 3M orange fluorescent VIP diamond grade materials, electro-cuttable films, overlay film, etc.

Where partial closures are necessary, reduction in the number of lanes available for traffic or construction of existing widths of traveled way will not be permitted until after 9:00 a.m. and shall be removed prior to 4:00 p.m. unless otherwise directed by the Engineer. Work will not be conducted on Saturdays, Sundays, or legal holidays, unless otherwise directed by the Engineer. A list of holidays observed by Union County will be provided to the Contractor at the pre-construction meeting.

159.03.10 Nighttime Operations.

THIS SUB-SECTION IS ADDED:

Under no circumstances will nighttime operations be allowed.

159.03.11 Detours.

THIS SUB-SECTION IS ADDED:

The Contractor shall be responsible for establishing (using appropriate signing that is installed in accordance with the requirements set forth in the current edition of the Manual on Uniform Traffic Control Devices (MUTCD) and maintaining the proposed detour routes, and work zones, as well as the work area(s) itself, insofar as it relates to maintenance and protection of traffic operations. Any detour route or road closure shall be approved by the County Engineer prior to implementation.

Notification must be made to residents and businesses within the limits of the closure five (5) business days prior to the closure. The Contractor shall notify residents and businesses of any closure by either written notice delivered to each property or post construction signs at the limits of the closure stating the date and length of time of the closure. Adequate directional and detour signs, acceptable to the County, shall be furnished and erected at the location where the county may direct. All work in connection with such detours shall be at no cost to the County.

It should be noted that at the conclusion of the workday, any detour routes will be discontinued and the area under construction reopened to traffic until the start of the following workday. Therefore, the Contractor shall ensure that all of his equipment and materials are removed from

the roadway, the road clear of debris and any raised manholes, inlets and other appurtenances have traffic control devices (i.e., drums) placed over them.

159.03.08 Traffic Direction

THIS SUB-SECTION IS CHANGED TO:

Traffic Directors will be utilized as directed by the Engineer. Traffic Director manpower not approved by the Engineer will not be reimbursed under this item and shall become the Contractor's sole responsibility.

B. Police. Police will be off-duty local police. Police are provided by the local government as a vendor to the County. The use of police services does not relinquish or diminish the Contractor's responsibilities for work zone safety.

Submit a request for police services to the RE 72 hours before beginning construction operations that require police services. Activities requiring police services include:

1. Traffic direction through signalized intersections, where the integrity of the existing traffic signal system is impacted or where an override of the signal is required.
2. Rolling slow-down or temporary closure of all lanes on state highways and interstates.

Emergency situations may prevent police from arriving at the scheduled date or time. The RE will not permit construction operations that, by law, require police services if police are unavailable. The Department will not accept claims for interruptions or delays resulting from any failure of police to arrive as requested.

The Contractor may request police services to enhance the TCP. Submit a request for police services to the RE 72 hours before beginning construction operations that require police services. The RE will determine the need for, and direct the use of, police for the following activities.

1. Night operations;
2. TCP setup or removal on high speed and high volume roads; and
3. Major traffic pattern changes.

The RE must notify State and local police of cancellations 24 hours in advance. At least 24 hours before the scheduled start of work, notify the RE of any work cancellation for which police services were requested.

159.04 MEASUREMENT AND PAYMENT

THE ENTIRE SUB-SECTION IS CHANGED TO:

The utilization of Police Officers to provide traffic safety services shall be at the direction of the Borough of Roselle and shall be paid for by the Borough of Roselle. The Contractor shall be responsible for paying the prevailing wage rate for the Traffic Directors where funds will be drawn from the bid contingency, as directed by the Engineer. The Contractor shall not be responsible for paying the prevailing wage rate for Police Traffic Directors.

Payment for the Traffic Directors by the Contractor shall be reimbursed under this contract, in accordance with the requirements stated herein and those of the respective Municipality. The Contractor shall be required to produce proof of *both* payment and hours worked for each traffic director at each post for each assignment. Should the Contractor fail to produce said proof, the County will withhold payment on this item until such time that adequate and satisfactory proof can be provided.

The Borough of Roselle shall direct the Contractor as to the number of traffic directors required per roadway. Under the circumstances where Police Traffic Directors may be utilized, the Contractor shall notify the respective Police Department at least four (4) business days (96 hours) in advance of requiring the traffic directors. Should there be a difference between the Engineer's requirement, and that of the Police Department, the Contractor shall immediately notify the Engineer and request clarification.

If the Contractor schedules more traffic directors than that which is directed by the Borough of Roselle, then, said additional directors will not be reimbursed, and such payments will be the direct responsibility of the Contractor. In addition, if the Contractor cancels any work, without prior notice to the affected Municipal Police Department and the Engineer, then any costs incurred from the respective Police Departments shall become the Contractor's responsibility. Police traffic director manpower not approved by the Engineer will not be reimbursed and shall become the Contractor's sole responsibility. The Contractor shall be responsible for establishing any and all escrow accounts that may be required by the various municipal Police Departments. The Contractor shall confirm specific details of hiring Traffic Directors with each respective Police Department. There will be no additional compensation for minimum call out requirements.

Once the traffic directors are on the job, the County will direct the Contractor as to the dismissal time for such Traffic Directors.

Measurement and Payment will be as follows:

<i>Item</i>	<i>Pay Unit</i>
Breakaway Barricade (Item 2)	Unit
Drum (Item 3)	Unit
Traffic Cone (Item 4)	Unit
Construction Signs (Item 5)	Square Foot

Separate payment will not be made for relocating traffic control devices. Separate payment will not be made for posts or stands for construction signs. Separate payment will not be made for traffic control coordinator. Separate payment will not be made for relocating temporary crash cushions as required or as directed. Separate payment will not be made for moving the traffic control truck units during the various stages of construction. Separate payment will not be made for escape ramps provided at the edges of pavement lifts or at excavations. All costs thereof shall be included in the price bid for the traffic control items listed above. If the Contractor fails to deliver to the job site or provide the appropriate and adequate traffic control devices, payment is subject to being withheld.

DIVISION 200 – EARTHWORK

SECTION 201 – CLEARING SITE

201.03 CONSTRUCTION

201.03.01 Clearing Site

B. Clearing and Grubbing.

THE FOLLOWING IS ADDED TO SUB-SECTION B

Remove all trees, shrubs, etc. and trim all tree and shrub branches that obstruct the view of the traffic signals and traffic signs as shown on the plans and as directed by the Engineer and in accordance with Section 802 of the Standard Specifications, except that said removals will not be measured nor paid for as a separate item. Removal of trees, shrubs, etc. and trimming shall be included in the lump sum price bid for the CLEARING SITE item.

THE ENTIRE SUB-SECTION C IS CHANGED TO:

C. Sign Relocation and Other Appurtenances. Remove local street and road signs and reset at locations and in the manner acceptable to local authorities. Ensure that Tourist Oriented Directional Signs and logo signs remain visible to motorists during and after stages of construction. Remove from the immediate work site and safely store existing signs that are to be reset.

The removal or relocation of existing signs shall also include accessory panels, hardware, posts and supports identified on the plans and patching and restoration (to the satisfaction of the Engineer) of existing sidewalk, grassy areas, etc., where the existing signs were previously. Signs and accessory panels removed under this contract shall be delivered to the County's Division of Engineering between the hours of 7:30 am and 3:00 pm. Posts removed under this contract shall be disposed of by the Contractor.

Remove or modify the existing planters as identified on the plans. Remove all unnecessary materials as required for construction and modify the planter in a manner acceptable to the owner.

Reset newsstands, planters and other appurtenances disturbed during construction. Remove all unnecessary materials as required for construction or as directed by the Engineer including other work that may arise during the course of construction that is not specifically stated herein.

G. Removing Electrical Material and Equipment.

THE SECOND PARAGRAPH OF SUB-SECTION G IS CHANGED TO:

The existing above ground electrical material and equipment designated for removal shall be salvaged in accordance to Subsection 701.03.01. Care shall be taken when removing existing signal equipment from the project area, as these salvaged materials will be returned to the respective Municipality for reuse or recycling. The Contractor shall make arrangements with the

Municipality for delivery of salvaged traffic signal equipment to the Public Works yard, or other designated area. Should the Municipality refuse delivery of the salvaged materials, the Contractor shall be responsible for disposal of all materials at no additional cost.

201.03.09 Disposal of Removed Materials and Debris

THE FOLLOWING IS ADDED:

Disposal of asphalt and concrete will be made to a NJDEP approved recycling facility. The Contractor shall notify the Recycling Facility to provide the County with appropriate credit for recycling.

201.04 MEASUREMENT AND PAYMENT

THE FOLLOWING IS ADDED:

Clearing site, including delivery of salvaged items (as described in subsections 201.03 and above) will not be measured. Payment will be made on a lump sum basis and in accordance with this subsection, for the item CLEARING SITE in the Bidding Sheets for the item

Measurement and Payment will be as follows:

<i>Item</i>	<i>Pay Unit</i>
Clearing Site (Item 7)	Lump Sum

SECTION 202 – EXCAVATION

202.01 DESCRIPTION

THE FOLLOWING IS ADDED:

This section shall also include the sawcutting and excavation of all curb, driveway, sidewalk and pavement areas that are determined unsuitable by the Engineer and/or require removal for constructing new curbs, sidewalk, driveways and pavement. During excavation, the Contractor may encounter combination concrete gutter/curb, underlying concrete road courses, steel reinforcement, etc. All work and materials necessary to excavate these areas, with the exception of the curb and sidewalk excavation itself (to be included under the respective items), shall be included for measurement and payment under this item. Materials necessary for restoration of the excavated area will be paid for under their respective items within this contract.

202.03 CONSTRUCTION

202.03.03 Excavating Unclassified Material

A. Excavating.

THE FOLLOWING IS ADDED TO SUBSECTION A:

This subsection shall include the excavation of curbs, driveways and sidewalk. The perimeter of areas to be excavated shall be sawcut. Sawcutting shall consist of making longitudinal and transverse cuts in sidewalk, driveways or curb, of whatever nature, as shown on the plans or as

directed by the Engineer. Sawcuts shall be made with an approved power saw full depth in order to prevent damage to the existing sidewalk, driveways or curbs and to provide a neat edge for the adjacent proposed, sidewalk, driveways or curbs as shown on the plans or as directed by the Engineer.

202.03.07 Reuse or Disposal of Excess Material

THE FOLLOWING IS ADDED:

Disposal of asphalt and concrete will be made to a NJDEP approved recycling facility. The Contractor shall notify the Recycle Facility to provide the County with appropriate credit for recycling.

202.04 MEASUREMENT AND PAYMENT

THE FOLLOWING IS ADDED:

Measure and Payment for the excavation and removal of pavement, driveways, and cut sections shall be made under the item EXCAVATION, UNCLASSIFIED. No separate payment will be made for the excavation and removal of curb and sidewalk, this work shall be paid for under their respective items within this contract.

Sawcut shall not be measured for payment but shall be included as part of the unit price bid for EXCAVATION, UNCLASSIFIED, as shown in the Bidding Sheets.

Measurement and Payment will be as follows:

<i>Item</i>	<i>Pay Unit</i>
Excavation, Test Pit (Item 8)	Cubic Yard
Excavation, Unclassified (Item 9)	Cubic Yard

DIVISION 300 – SUBBASE AND BASE COURSES

SECTION 302 – AGGREGATE BASE COURSE

302.01 DESCRIPTION

THE ENTIRE SECTION IS CHANGED TO:

This section describes the requirements for construction aggregate base course which will be used as base materials in the roadway as shown on the plans, in the construction details, or as directed by the Engineer.

Dense graded aggregate (DGA) base course will be used as shown on the construction details within widening areas and to reconstruct the road sub-base after excavation of the existing curb. The Engineer may also direct the Contractor to utilize DGA at other locations within this project such as to replace unsuitable backfill material in the conduit trench.

302.02 MATERIALS

302.02.01 Materials

THE FOLLOWING IS ADDED:

Dense graded aggregate base course for this project may be produced from recycled concrete aggregate or reclaimed asphalt pavement (RAP) conforming to subsection 901.05.04.

302.03 CONSTRUCTION

302.03.01 Aggregate Base Course

THE FOLLOWING SUBSECTION IS ADDED:

F. Maintenance Under Traffic. When it is provided on the plans that traffic is permitted to ride on the completed base course, the base course shall be maintained smooth and uniform until covered by the following stage of construction.

302.04 MEASUREMENT AND PAYMENT

THE FOLLOWING IS ADDED:

Measurement and Payment will be as follows:

<i>Item</i>	<i>Pay Unit</i>
Dense Graded Aggregate Base Course, 4" Thick (Item 10)	Square Yard

DIVISION 400 – PAVEMENTS

SECTION 401 – HOT MIX ASPHALT (HMA) COURSES

401.03 CONSTRUCTION

401.03.01 Preparing Existing Pavement

THE FOLLOWING REPLACES THE FIRST PARAGRAPH OF SUBSECTION D:

D. Repairing HMA Pavement. This section shall refer to those areas of roadway that require repair due to unstable subsurface conditions and shall be as directed by the RE.

Sawcut existing HMA pavement to a maximum depth of 10 inches, or to the full depth of bound layers, whichever is less. Sawcut lines parallel and perpendicular to the roadway baseline and 3 inches away, at the closest point, from the damaged area to be repaired. For larger areas, the Contractor may use a milling machine for removal of HMA pavement.

THE THIRD PARAGRAPH IS CHANGED TO:

Apply polymerized joint adhesive or tack coat to the vertical surfaces of the openings. Backfill with HMA as specified for the roadway surface. HMA Pavement Repair shall include all courses where necessary including HMA surface course 9.5M64, HMA base course 19M64 and dense-graded aggregate (DGA) base course. Ensure that the temperature of the HMA when placed is at least 250 °F, and compact as specified in 401.03.03.F. Compact areas not accessible to rollers with a vibratory drum. Compact until the top of the patch is flush with the adjacent pavement surface.

401.04 MEASUREMENT AND PAYMENT

THE ENTIRE SUBSECTION IS CHANGED TO:

Tack coat and prime coat shall not be measured for payment. Costs for tack coat and prime coat shall be included in the unit price for various hot mix asphalt items.

The unit price for HOT MIX ASPHALT PAVEMENT REPAIR shall include the cost for all courses, where necessary, including HMA surface course 9.5M64, HMA base course 19M64 and dense-graded aggregate (DGA) base course.

Separate payment will not be made for: MTV, test strips, quality control for compaction (including comparison cores and nuclear density testing), prime coat, tack coat and polymerized joint adhesive. All costs thereof shall be included in the unit price for various hot mix asphalt items.

Measurement and Payment will be as follows:

<i>Item</i>	<i>Pay Unit</i>
Hot Mix Asphalt 9.5M64 Surface Course (Item 11)	Tons
Hot Mix Asphalt 19M64 Base Course (Item 12)	Tons

DIVISION 600 – MISCELLANEOUS CONSTRUCTION

SECTION 606 – SIDEWALKS, DRIVEWAYS AND ISLANDS

606.01 DESCRIPTION

THE FOLLOWING IS CHANGED TO:

This section describes the requirements for the construction of sidewalks, sidewalk curb ramps, and driveways.

The construction of sidewalks shall consist of the removal and disposal of any existing concrete or bituminous concrete walks and ramps; excavation to the proper depth all around; setting forms as required; placing a 4" stone subbase as required; pouring and finishing of concrete sidewalk and ramp, or placing and finishing hot mix asphalt as required at each location. After the stripping of forms, each site will be cleaned and restored to match all adjacent conditions, including topsoil and seeding as required.

All handicap accessible ramps shall be included in the unit price for concrete sidewalks, and shall consist of providing a sidewalk ramp in compliance with the requirements of the Americans with Disabilities Act, including concrete retaining headers where required. Detectable warning devices will be applied to each ramp identified within the project limits. New concrete ramps will receive cast in concrete detectable warning devices while existing ramps will receive the retrofit detectable warning device application.

PRIOR TO BEGINNING ANY WORK ON PUBLIC SIDEWALK CURB RAMPS, THE CONTRACTOR SHALL FIELD VISIT AND VERIFY ALL LOCATIONS FOR EACH RAMP TO CONFIRM THE RAMP LOCATION AND AREAS OF SIDEWALK TO BE REPLACED WITH THE ENGINEER TO VERIFY THE LIMITS OF DISTURBANCE AND REPLACEMENT.

606.03 CONSTRUCTION

606.03.02 Concrete Sidewalks, Driveways and Islands

SUBSECTION A IS CHANGED TO:

- A. **Underlayer Preparation.** Excavate as specified in 202.03.03. A layer of AASHTO Type 67 stone subbase shall be placed immediately below new concrete sidewalks and driveways at a thickness specified on the plans. This subbase shall be constructed in accordance with Section 301.

SUBSECTION E IS CHANGED TO:

- E. **Expansion Joints.** Construct 1/2-inch wide expansion joints, placed at intervals of approximately 12 feet, with preformed joint filler. If the sidewalk, driveway, or island is constructed on a concrete surface, install expansion joints directly over the expansion joints

in the underlying concrete surface. Construct expansion joints around all appurtenances, such as manholes and utility poles, and between new concrete and any fixed structure, such as a curb, walls, buildings, or bridges. Ensure that the expansion joint material extends for the full depth.

Clean the top and ends of expansion joint material of all excess concrete, and trim the expansion joint material slightly below the surface of the concrete.

THE FOLLOWING IS ADDED SUBSECTION F:

F. Placing Concrete

New sidewalk shall meet existing sidewalk, at an existing joint.

THE FOLLOWING IS ADDED TO SUBSECTION G

G. Finishing Concrete

Sidewalks shall be constructed in 4 ft. x 4 ft. squares using approved separators.

606.03.03 Detectable Warning Surfaces

THE FOLLOWING IS ADDED:

Detectable warning devices shall be installed in accordance with the **Revised ADA Regulations implementing Title II and the 2010 ADA Standards for Accessible Design requirements**, and as amended herein. Truncated Domes are the only detectable warning devices allowed by the ADA. Grooves & exposed aggregate will not be acceptable.

606.04 MEASUREMENT AND PAYMENT

THE ENTIRE SUBSECTION IS CHANGED TO:

Separate payment will not be made for the excavation and removal of unclassified excavation necessary for the placement of new sidewalk. Separate payment will not be made for clean stone subbase to be placed below new concrete sidewalks and driveways. Separate payment will not be made for concrete curb type retaining headers required for ADA compliant curb ramps. The materials, preparation and compaction of the subbase shall be made part of the unit price for item CONCRETE SIDEWALK, 4" THICK.

Payment will not be made for areas disturbed by construction operations beyond the prescribed grading limits. All areas damaged by construction equipment or construction operations shall be repaired or replaced in kind at no cost to the County. This includes but is not limited to damaged sidewalk, driveway aprons, grass areas, curbs, landscaping, utility conduit and lines or personal property.

Measurement and Payment will be as follows:

<i>Item</i>	<i>Pay Unit</i>
Concrete Sidewalk, 4" Thick (Item 13)	Square Yard
Detectable Warning Surface (Item 14)	Square Yard

SECTION 607 – CURBS

607.01 DESCRIPTION

THE FOLLOWING IS ADDED:

This section describes the requirements for the removal and disposal of any existing concrete, granite block, and/or bituminous concrete curb; excavation to the proper depth; setting forms as required; placing 4" stone base as required; drilling, grouting and installation of dowels as required; pouring and finishing concrete curb, as required at each location.

After the stripping of forms, each site will be cleaned and restored to match all adjacent conditions, including associated topsoil and seeding as required. All curbs shall be depressed at driveways and at handicap sidewalk ramps, in accordance with the respective construction details.

607.04 MEASUREMENT AND PAYMENT

THE ENTIRE SUBSECTION IS CHANGED TO:

The quantity of curb for which payment will be made will be the length actually constructed, measured in linear feet along the face at the gutter line.

All materials and equipment necessary to complete curb installation will be included in the bid prices for these items.

Separate payment will not be made for the excavation and removal of unclassified excavation necessary for the placement of new curb.

Separate payment will not be made for the cost of expansion joint material. The cost for expansion joint material should be included in the cost of the curbs.

Measurement and Payment will be as follows:

<i>Item</i>	<i>Pay Unit</i>
10" x 20" Concrete Vertical Curb (Item 15)	Linear Foot

SECTION 610 – TRAFFIC STRIPES, TRAFFIC MARKINGS AND RUMBLE STRIPS

610.03 CONSTRUCTION

THE FOLLOWING IS ADDED:

This work shall consist of applying latex traffic paint to new and existing curbing. The area to be painted shall be power washed and cleaned of any debris prior to application. Paint spilled or applied to the adjacent sidewalk or pavement shall be removed to the satisfaction of the Engineer at no cost.

Materials.

Materials shall be yellow latex traffic marking paint capable of adhering to new and existing curbs.

610.03.02 Thermoplastic Traffic Markings

THE FOLLOWING IS ADDED TO SUBSECTION C:

C. Applying Long-Life Traffic Markings

All traffic stripes, words, legends and markings shall conform to the current edition of the Manual on Uniform Traffic Control Devices for size, color, shape and placement.

All centerline markings shall be a four-inch wide double yellow line. Additionally, the Contractor performing this work shall provide a six-inch wide gap between the double yellow lines for the placement of plowable raised pavement markers, either installed under this or future contracts. In the event that a six-inch wide gap is not provided, the Contractor performing the work shall remove that length of road that is not in compliance and reapply the material to provide the required gap distance without additional compensation.

THE FOLLOWING IS ADDED TO SUBSECTION D:

D. Defective Markings

At no additional compensation by the County, the Contractor shall remove all traffic paint where the striping or markings will not be directly under long-life material, replace long-life traffic stripes or traffic markings damaged due to any sawing or sealing of joints in the HMA overlay, and replace all existing pavement reflectors that have been marred by striping or marking material as a result of improperly located traffic stripes or traffic markings.

SUBSECTION E IS CHANGED TO:

- E. Opening to Traffic.** Complete each application of traffic markings and allow to thoroughly dry. All stray materials which result from the application of traffic lines and markings shall be cleaned up and disposed of prior to opening the road to traffic and to the satisfaction of the Engineer. The use of grinders or similar method will not be allowed on newly paved surfaces. Additionally, where applicable, excess glass beads that are on the roadway surface shall be cleaned up prior to opening the road to traffic. The beads must be swept or vacuumed up - the use of blowers to clean the roadway surface of glass beads is not an acceptable method of removal.

610.03.08 Removal of Traffic Stripes and Markings

THE FOLLOWING IS ADDED:

Under this contract, there may be locations in which existing striping conflicts with the proposed permanent striping. In this case, the Contractor or Sub-Contractor shall remove the existing striping as directed by the Engineer.

610.04 MEASUREMENT AND PAYMENT

THE ENTIRE SECTION IS CHANGED TO:

It shall be the responsibility of the Contractor performing this work to provide a breakdown of materials and footage applied at the end of each workday to the County. In the event of a discrepancy between the County and the Contractor's as-built quantity, both the County and the Contractor will re-measure all roads to resolve their differences. This will take place before final contract payment occurs.

The quantity shown in the Bidding Sheets represents the total 4-inch line equivalent for the Traffic Striping.

Traffic markings of the various types and materials for words, arrows or other pavement symbols will be measured by the unit.

Payment for traffic stripes will be made for the number of linear feet installed, accepted and placed in accordance with the requirements of these and the manufacturer's specifications at the price bid per linear foot of 4" equivalent stripe under the item TRAFFIC STRIPES, LONG LIFE, THERMOPLASTIC.

Payment for traffic markings will be made by the unit of markings installed, accepted and placed in accordance with the requirements of these and the manufacturer's specifications at the price bid per unit under the item TRAFFIC MARKINGS, LONG LIFE, THERMOPLASTIC.

Payment for the removal of traffic stripes will be made for the number of linear feet removed at the price bid per linear foot of 4" equivalent stripe under the item REMOVAL OF TRAFFIC STRIPES.

Payment for the removal of traffic markings will be made by the unit removed at the price bid per unit under the item REMOVAL OF TRAFFIC MARKINGS.

Measurement and Payment will be as follows:

<i>Item</i>	<i>Pay Unit</i>
Traffic Stripes, Long-Life, Thermoplastic (Item 16)	Linear Foot
Removal of Traffic Stripes (Item 17)	Linear Foot

SECTION 612 – SIGNS

612.01 DESCRIPTION

THE FOLLOWING IS ADDED:

This Section describes the requirements for fabricating, finishing, assembling and erecting signs. Post and mounting hardware shall be included in the unit price bid for the items specified in the Section.

Pole mounted signs shall consist of fabricating and installing new traffic sign faces and mounting hardware to attach to a traffic signal pole

All signs shall be mounted on breakaway steel “U” post sign supports.

612.03 CONSTRUCTION

THE FOLLOWING SECTIONS ARE ADDED:

612.03.04 Removal and Relocation of Existing Signs

The removal and relocation of existing signs, accessory panels and posts and restoration of the surrounding area is included in the price bid for CLEARING SITE. Signs scheduled for removal shall not be removed until the new sign and/or accessory panels are installed. Borough Owned Flashing Stop Signs should be carefully removed and replaced with regular stop signs upon the start of construction. The solar powered stop signs should be returned to ROSELLE PUBLIC WORKS immediately upon commencement of construction to avoid any damage to them.

612.03.05 Overhead Street Signs (Mast Arm Sign)

This project specifies the use of Overhead Street Signs, Type SF and Type DF. Type DF signs are double-faced signs bearing a cross street name on both sides. Type SF signs are single-faced signs bearing a cross street name on the side facing traffic.

This item includes furnishing and installing the sign (i.e., sheeting and aluminum blank), hardware to mount the sign on the traffic signal arm, miscellaneous hardware, fittings, labor, equipment, etc., to complete this item.

Overhead street name signs shall be installed only after the end and mid-mount traffic signals are installed, to ensure proper clearance, spacing and visibility of both the traffic signals and overhead signs. Lateral spacing between the near edge of signs and traffic signals mounted on the mast arm shall be a minimum of 6-inches to avoid entangling the sign and signal.

Prior to installation, the Engineer shall inspect the sign faces and hardware to ensure conformance with the plans and specifications.

612.04 MEASUREMENT AND PAYMENT

Measurement and Payment will be as follows:

<i>Item</i>	<i>Pay Unit</i>
Regulatory & Warning Sign (Item 18)	Square Foot
Mast Arm Sign, Type DF (Item 19)	Square Foot

DIVISION 700 – ELECTRICAL

SECTION 701 – GENERAL ITEMS

701.01 DESCRIPTION

THE ENTIRE SECTION IS CHANGED TO:

This section describes the requirements for constructing and installing various electrical items. Electrical items associated with this project include rigid metallic conduit, junction boxes, foundations, junction box frames and covers, meter cabinets, cable and wire.

701.03.02 Rigid Metallic Conduit (Earth)

SUBSECTION C IS CHANGED TO:

- C. **Backfilling.** Ensure that conduit is centered in the trench and is held firmly in place while the trench is backfilled. Backfill with suitable excavated material that is free from rock larger than 2 inches in diameter in lifts not exceeding 6 inches thick, loose measurement. If the excavations do not provide sufficient material of the quality required for backfilling, the Engineer shall be notified and an alternate material may be substituted. *This substitution shall only take place upon the approval of the Engineer.* Material specifications may be required from the Contractor for submission and review prior to approval by the Engineer. Payment for alternate material shall be agreed upon prior to furnishing and placement of material. Compact the backfill using the directed method as specified in 203.03.02.C. Restore the disturbed areas to original conditions, the conditions specified in the Contract, or as directed by the RE.

701.03.03 Rigid Metallic Conduit (Roadway)

THE FOLLOWING IS ADDED:

Trenches for conduit constructed under roadways shall be filled with NJDOT Class B concrete up to the top of the trench less two inches for hot mix asphalt restoration, and shall completely encase the newly laid conduit runs. Any conduit constructed under roadways that are cut through a striped crosswalk and that will not be restored with permanent hot mix asphalt within 24 hours of filling the trench with concrete will be restored with temporary asphalt. This temporary restoration will be constructed in accordance with Section 401 and shall be considered as part of this item and shall be included in the unit price.

It shall be the responsibility of the Contractor to obtain all approvals and inspections necessary to fulfill the respective utility company's requirements for installing the service conduit for electrical power service to the new traffic signal installation.

701.03.08 Junction Boxes

THE FOLLOWING IS ADDED:

Junction box covers shall be stamped with the logo "Traffic Signal". The cover for the 24" x 36" Junction Box shall green if installed in grassy areas, gray if installed in concrete areas, or as directed by the Engineer. Stamping and colors shall be supplied by the manufacturer only. Stamping and spraying of covers on-site or in the Contractor's yard is not acceptable. At the request of the Engineer, the Contractor shall supply all necessary invoices as proof the covers were prepared by the manufacturer.

Holes needed to accept the various size and types of conduit that terminate at the boxes shall be made in accordance with the requirements found in the project detail sheets. Holes made in any other manner than those specified on the detail sheets are not acceptable. The use of hammers, chisels, cut-off saws, etc., to make holes in the junction boxes will not be allowed.

Boxes that are damaged or broken by the Contractor while making holes for conduits shall either be repaired to the satisfaction of the Engineer or replaced without additional compensation.

All conduits terminating at splice boxes shall be sealed to prevent water from entering the boxes or vice versa. Duct Seal or other suitable material for this purpose shall be used. Material must be UL listed and meet the requirements of the National Electric Code.

701.03.12 Foundations

THE FOLLOWING IS ADDED:

Prior to any concrete placement, the Contractor shall obtain approval of the excavation and formwork for the foundations. Foundations poured without prior approval will not be considered for payment. Additionally, foundations poured improperly (i.e., location, depth, etc.) as determined by the Engineer, shall be completely removed, re-excavated, re-formed and re-poured. This shall be done without additional compensation.

If foundations are not poured the same day they are excavated, they shall be inspected by the Engineer to determine if the condition of the excavation is suitable for pouring. Any standing water in the bottom of the foundation shall be removed to a depth of one inch. Quarry processed stone shall then be placed in the excavation, as directed by the Engineer. No additional compensation will be made for this work but it shall be included as part of the unit price bid for this item.

The Contractor shall ensure that the proper grades are established for the foundations. The Contractor shall verify all finished grades with the Engineer prior to pouring any foundations.

701.03.14 Meter Cabinets

THE FOLLOWING IS ADDED:

Powder coat gloss black in accordance with section 702.03.01. Cabinets that are scratched, nicked or otherwise damaged shall be repaired or replaced to the satisfaction of the Engineer, without additional compensation. Irregular patterns and/or circular scratches are not acceptable.

701.03.15 Cable and Wire

THE FOLLOWING IS ADDED TO SUBSECTION C:

C. Connections and Coordination with Utility Service

It shall be the responsibility of the Contractor to obtain the respective utility company's requirements for establishing the required connections for electrical power service to the new traffic signal installations.

701.04 MEASUREMENT AND PAYMENT

THE ENTIRE SUBSECTION HAS BEEN CHANGED TO:

The quantity of conduit, wire and traffic signal cable for which payment will be made will be the actual length installed for each type, measured in linear feet, in accordance with the plans and specifications.

Backfilling, soiling and seeding (as required), and restorative work will be considered as part of the installation for these items and shall be included in the unit price bid for these items. No additional compensation will be made for this work.

Measurement and Payment will be as follows:

<i>Item</i>	<i>Pay Unit</i>
2" Rigid Metallic Conduit, Earth (Item 20)	Linear Foot
4" Schedule 80 PVC, Earth (Item 21)	Linear Foot
4" Schedule 80 PVC, Roadway (Item 22)	Linear Foot
18" x 36" Junction Box (Item 23)	Unit
24" x 36" Junction Box (Item 24)	Unit
Foundation, Type SFT (Item 25)	Unit
Foundation, Type P-MC (Item 26)	Unit
Foundation, Type SPF (Item 27)	Unit
Meter Cabinet, Type T (Item 28)	Unit
Service Wire, No. 6 AWG (Item 29)	Linear Foot
Ground Wire, No. 8 AWG (Item 30)	Linear Foot

SECTION 702 – TRAFFIC SIGNALS

702.03 CONSTRUCTION

702.03.01 Controller

THE FOLLOWING IS ADDED:

The controllers shall be model ASC/3-2100, as manufactured by *Econolite Control Products, Inc., 3360 E. La Palma, Anaheim, CA, telephone (714) 630-3700 / fax (714) 630-6349*; or an approved equivalent.

Each controller shall be mounted on an 18” aluminum skirt with adjustable shelves. The 18” aluminum skirt shall be of the same manufacturer as of the controller cabinet. Controller shall be equipped with an uninterruptible power source (UPS) unit in each controller cabinet installed. The UPS shall be capable of running the intersection at full operation for 6-8 hours at 600 watts and shall be compatible with all other equipment. The UPS unit shall be self mounted and the battery pack shall be self mounted on the sidewall of the controller cabinet skirt. **The controller shall be equipped with hot-swap bypass switch with a generator connection accessible from the outside of the controller cabinet.**

The Contractor shall submit to the Engineer for review and approval, catalog cuts and a fully wired cabinet depicting placement of a fully equipped controller cabinet with UPS equipment and battery pack before final approval is given to proceed.

The controller shall include a GPS based time clock, which can supply a momentary relay closure to the controller. The time switch shall have the capability of automatically setting the day-of-week and time-of-day using GPS technology. The time switch shall reset to GPS day and time at least once per day.

Cabinets

All cabinets shall be powder-coated gloss black. Powder coating shall be applied during fabrication, either in-house or as a contracted service.

Cabinets shall be cleaned prior to the powder coat process. To facilitate adhesion of the powder, the arms and poles shall have a minimum 80-grit rotary-sanded satin brush finish.

The applied finish shall be a thermosetting powder coat. The powder resin shall be type TGIC polyester or approved equal. If necessary, the aluminum parts shall be preheated to sufficient temperature prior to the coating process to insure all water vapor is removed and to aid the fusing of the powder to the aluminum.

The powder shall be applied by electrostatic spraying. After spraying, the parts shall be oven cured for a cycle of 5 to 15 minutes at a temperature between 375-400 degrees Fahrenheit.

The final coating film thickness shall be between 3 and 5 mils.

Before shipping, the manufacturer shall perform a thorough visual inspection to assure there are no finish flaws. Any touch-up or recoating necessary shall be performed prior to shipping.

A spray can of matching touch-up paint shall be supplied for every unit furnished and installed. Touch-up paint shall be delivered to the Engineer at the same time the poles, transformer bases and other hardware is delivered. The paint shall not be used to touch up scratches, scuffs or other marks made during handling by the Contractor or others. If any poles, bases or hardware are damaged, the Contractor shall be responsible for correcting the damage to the satisfaction of the Engineer.

The Contractor shall exercise extreme caution while handling the cabinets. Cabinets that are scratched, nicked or otherwise damaged shall be repaired or replaced to the satisfaction of the Engineer, without additional compensation. Irregular patterns and/or circular scratches are not acceptable.

702.03.04 Traffic Signal Cable

TABLE 702.03.04-1 IS CHANGED TO:

Color code traffic signal circuits and wires as follows:

Table 702.03.04-1 Conductor Cable Assignments			
	Function (Face)	Color	Number
Two-Conductor Cable	Pedestrian Push Button	Black	1
	Neutral	White	2
Five-Conductor Cable (Pedestrian Signal)	Don't Walk	Black	1
	Walk	White	2
	Neutral	Red	3
	Spare	Green	4
	Spare	Orange	5
Ten-Conductor Cable (Traffic Signal) (All Heads Wired Separately)	Red	Black	1
	Green	White	2
	Yellow	Red	3
	Neutral	Green	4
	Spare	Orange	5
	Red	Blue	6
	Green	White-Black	7
	Yellow	Red-Black	8
	Neutral	Green-Black	9
	Spare	Orange-Black	10

702.03.11 Temporary and Interim Traffic Signal Systems

The following is added

If temporary or interim traffic signal systems are required during construction, the Contractor shall submit working drawings for approval at least 30 days before starting the installation.

702.03.12 Controller Turn-On

The following is added to this Subsection:

The Contractor shall notify the County that the traffic signal system along with all signs and pavement markings are completed and may be inspected to ensure conformance with the Contract requirements. The traffic signal system inspection shall be performed within four working days of notification. This procedure shall be repeated until all required items are completed. Traffic signal activation (flash mode) will be scheduled upon completion of all traffic signal system items. For traffic signal activation (flashing and normal operation), a technician representing the controller manufacturer shall be present at the site. Maintenance acceptance will be considered only after all testing has been completed, defects corrected, all indications are operational and properly aimed, cables tagged, controller fully operational performing all timing functions required, and all other items of work within the project limits are completed.

The activation of the traffic signal system shall be performed in accordance with the following procedure for a **New Traffic Signal System**.

Phase 1 – Inspection

1. All testing shall be completed and successful, all defects and deficiencies corrected, all indications operational and properly aimed, cables tagged, all other items of work associated with the signal completed, and all signs and pavement markings properly installed at least six working days before the scheduled activation (flashing mode) of the signal.
2. The County shall perform a final inspection of the signal system within four days, and upon satisfactory conditions of the signal system, will confirm the scheduled activation (flashing mode) date. Any deficiencies found during the final inspection will result in the activation (flashing mode) being re-scheduled.
3. The image detection system shall be completely established and operational at the time of inspection. The image detection system software and training shall be provided to the County prior to scheduling of activation (flashing mode) date.
4. The Contractor shall provide an As-Built Electrical Plan to the County prior to scheduled activation (flashing mode). All Costs for same shall be included in the prices bid for the various electrical pay items in the Proposal.

Phase 2 - Flashing Operation

Variable Message Signs (VMS) advising the motorists of the signal activation shall be posted on the day of signal activation (flashing mode) on all approaches to the intersection. VMS shall be provided by the contractor. The message shall read “Signal Turn On” “Date”.

Actual activation (flashing mode) shall consist of the following steps:

- a) required personnel - representatives of the General Contractor, Electrical Contractor with appropriate equipment, and the manufacturer of traffic signal control components
- b) installation of all required equipment in the controller cabinet by the representative of the manufacturer of traffic signal control components
- c) testing of installed equipment (timings, conflicts, push buttons, other detection, etc.)
- d) unbagging of all signal heads, and signs if applicable**
- e) disconnecting of the existing traffic signal system, if applicable**
- f) activation of the signal
- g) minor re-aiming of signal heads, if necessary
- h) removal of the disconnected existing traffic signal system

Uniformed police officers shall be present at the site to direct traffic and ensure safety to the traveling public as well as to all construction personnel throughout this step.

Flashing operation shall last at least three (3) consecutive days but not more than seven (7) days. After seven (7) days of flashing operation, the signal will be disconnected and bagged. (The existing flashing beacon, if in place, shall be immediately removed when the new signal is activated and operates in flashing mode).

Phase 3 - Normal Operation

1. Actual activation shall consist of the following steps:
 - a. required personnel - representatives of the General Contractor, Electrical Contractor with appropriate equipment, County's Engineering Department and the manufacturer of traffic signal control components
 - b. unbagging and/or removal of signs if applicable
 - c. activation of the signal
 - d. final testing of controller equipment under normal operation conditions by the representative of the controller manufacturer
 - e. minor re-aiming of signal heads, if necessary
 - f. removal of VMS
2. Observation of signal operation and traffic flow.

Uniformed police officers shall be present at the site to direct traffic and ensure safety to the traveling public as well as to all construction personnel throughout this step.

3. Fine-tuning and modifications of the traffic control devices as directed by the Engineer.

No traffic signal system activation shall be scheduled for Mondays, Fridays or days right before holidays.

THE FOLLOWING SUBSECTIONS ARE ADDED

702.03.13 Single Member Arm and Shaft Assembly

This project specifies Single Member Arm and Shaft Assemblies specific to Union County. Single member arm and shaft assemblies consist of an aluminum arm (size as indicated on the plans), shaft, transformer base (size and type as indicated on the detail sheets), traffic signals, light fixtures, required mounting hardware, safety chains and other miscellaneous hardware. They are mounted on foundation, type SFT or foundation, type SFT-H.

Assemblies designated TBn-2 indicate there are two free swinging end signals; a TBn-1 designation indicates there is one free-swinging end signal and a TBn-3 indicates there are three free swinging end signals, where "n" represents the size of the transformer base for the pole.

Single member arm and shaft assemblies shall be stamped to ensure proper mating. The Contractor shall ensure that the correct arm assembly is mated to the shaft.

All poles, bases and hardware shall be powder-coated gloss black. The pole manufacturer shall apply the powder coating during fabrication, either in-house or as a contracted service. The cost for powder coating the poles, bases and other hardware shall be part of the unit price bid for the respective items under this contract.

Aluminum poles, arms and transformer bases shall be cleaned prior to the powder coat process. Arms and poles shall be cleaned by the immersion process using both an alkaline and acid bath before any fabrication welding. To facilitate adhesion of the powder, the arms and poles shall have a minimum 80-grit rotary-sanded satin brush finish.

The applied finish shall be a thermosetting powder coat. The powder resin shall be type TGIC polyester or approved equal. If necessary, the aluminum parts shall be preheated to sufficient temperature prior to the coating process to insure all water vapor is removed and to aid the fusing of the powder to the aluminum.

The powder shall be applied by electrostatic spraying. After spraying, the parts shall be oven cured for a cycle of 5 to 15 minutes at a temperature between 375-400 degrees Fahrenheit.

The final coating film thickness shall be between 3 and 5 mils.

Before shipping, the manufacturer shall perform a thorough visual inspection to assure there are no finish flaws. Any touch-up or recoating necessary shall be performed prior to shipping.

A spray can of matching touch-up paint shall be supplied for every unit furnished and installed. Touch-up paint shall be delivered to the Engineer at the same time the poles, transformer bases and other hardware is delivered. The paint shall not be used to touch up scratches, scuffs or other marks made during handling by the Contractor or others. If any poles, bases or hardware are

damaged, the Contractor shall be responsible for correcting the damage to the satisfaction of the Engineer.

All traffic signal heads are to be fabricated from polycarbonate material and are to be black in color. Lenses are to be provided for all signal faces. In instances where a left or right turn arrow is shown as part of a four-section head, the signal section shall be comprised of dual row LED, with separate colors for green and yellow. In instances where left or right turn arrow is shown as part of a three section head (i.e. protected operation), the signal section shall be comprised of triple row LED.

Full tunnel visors are to be provided for all signal faces except as noted on the plans and shall be black in color. **All traffic signal indications including pedestrian indications shall be illuminated by LED.** Incandescent bulbs will not be allowed. Pedestrian signal housings shall be gloss black in color.

Where specified in the contract drawings, traffic signal faces shall be equipped with cut-off louvers, positioned horizontally.

702.03.15 Pedestrian Signal Assembly, Type W-1

This project specifies the use of Pedestrian Signal Assemblies. Pedestrian Signal Assembly, Type W-1 (Countdown) consists of furnishing and installing a pedestrian signal head (size and type as indicated on the plans) with pole clamp mounting, mounting hardware and signal cable from the terminal block of the signal to the base of the standard. The signal head shall be fabricated from polycarbonate material. The pedestrian signal assembly shall be LED, and shall have count-down capabilities.

All pedestrian signal assemblies supplied for this project shall have count-down capabilities.

These items will be constructed in accordance with the plans, details and Section 702 of the standard specifications.

702.03.16 Push Button Assembly

This project specifies the use of Push Button Assemblies. Push Button Assemblies shall consist of furnishing and installing the push button, housing, cable from the push button to the base of the standard, and instruction sign along with mounting hardware. All push buttons shall operate on logic ground.

Accessible Pedestrian Signals (APS) shall be utilized on this project and shall meet all requirements of the ADA guidelines. APS shall be incorporated into the pedestrian push button device and shall be in accordance with the “2 Wire Navigator Push Button Station” as manufactured by Polara Engineering Inc, Fullerton, CA 92833, or approved equal.

These items will be constructed in accordance with the plans, details and Section 702 of the standard specifications.

All mounting fittings shall be specifically designed to function with the traffic control device installed and shall provide the proper clearance to aid and adjust the device. Fittings and mounting hardware not shown in the plan shall conform to the recommendations of the manufacturer.

702.03.17 Pedestal Assembly

This project specifies the use of Pedestal Assemblies. Pedestal Assemblies consist of furnishing and installing a pedestal pole with base and slip-fitter cap, miscellaneous fittings and hardware, traffic or pedestrian signal head or both and traffic signal cable from the terminal block of each face to the base of the standard.

PEDESTAL ASSEMBLIES (HEIGHT 8 FEET, UNLESS OTHERWISE SHOWN)

Type	No. of Std. Faces	No. of Ped. Faces	No. of Prog. Faces	No. of Spider Assemblies
PW-1	0	1	0	0

702.03.19 Video Detection System

One video detector assembly shall be installed opposite each intersection approach under this contract. This item shall consist of furnishing and installing the video detector assembly on a traffic signal mast arm, mounting hardware, the drilling of the traffic signal mast arm, installing the grommet, video pigtail cable with round locking-type military style connector from the video detector assembly to the base of the traffic signal assembly and be incorporated into a video detection system as described hereafter. All assemblies shall be enclosed in weather tight aluminum housing.

All mounting brackets and hardware shall be finished to match the color of the single member arm and shaft assemblies upon which they will be mounted.

702.04 MEASUREMENT AND PAYMENT

THE ENTIRE SUBSECTION HAS BEEN CHANGED TO:

Measurement and Payment will be as follows:

<i>Item</i>	<i>Pay Unit</i>
Controller Assembly, 12 Phase w/Battery Backup System (Item 31)	Unit
UC-SMA15-TB2-2 Single Member Arm and Shaft Assembly (Item 32)	Unit
Pedestrian Signal Assembly, Type W-1 (Item 33)	Unit

Pedestal Assembly, Type PW-1 (Item 34)	Unit
Pedestrian Push Button Assembly, R10-3e (Item 35)	Unit
Traffic Signal Cable, 2 Conductor (Item 36)	Linear Foot
Traffic Signal Cable, 5 Conductor (Item 37)	Linear Foot
Traffic Signal Cable, 10 Conductor (Item 38)	Linear Foot
Video Detection System (Item 39)	Unit

The quantity of traffic signal assemblies and traffic signal standards for which payment will be made will be for the actual number constructed, measured in units in accordance with the plans, details and specifications.

Temporary traffic signal systems and overhead wiring or related items shall not be paid for separately. The costs shall be included in the various costs bid for the other traffic signal items.

The cost for APS units and the associated control unit shall be included in the unit price bid for the pay item PEDESTRIAN PUSH BUTTON ASSEMBLY.

The unit price for Video Detection shall include providing wiring connections to the controller cabinet, using cable supplied by the manufacture. No separate payment for this wire will be made. Payment for this item will be made on a unit basis per intersection furnished and installed at the unit price bid for the item VIDEO DETECTION SYSTEM in the bidding sheets.

No separate payment shall be made for Controller Turn-On, including VMS boards, but all costs shall be included in the unit prices bid for the various items included in the Proposal.

DIVISION 800 – LANDSCAPING

SECTION 802 – TRIMMING AND REMOVING TREES

802.04 MEASUREMENT AND PAYMENT

THE ENTIRE SUBSECTION IS CHANGED TO:

The trimming and removing of trees shall be in accordance with Section 802. Separate measurement and payment will not be made under this subsection for the trimming and removal of trees. Payment for work performed in accordance with Section 802 shall be included in the lump sum price bid for the item, CLEARING SITE.

SECTION 804 – TOPSOILING

804.04 MEASUREMENT AND PAYMENT

THE ENTIRE SECTION IS CHANGED TO:

Measurement and payment for topsoil shall be made under the item, TOPSOILING, 4" THICK. Topsoiling required for grass restoration as a result of grass areas disturbed by construction operations such as foundations, conduit runs, junction boxes, curb, sidewalk or for demolished items shall not be included under this pay item. Payment for restoration in these areas shall be included as part of their respective construction items.

Measurement and Payment will be as follows:

<i>Item</i>	<i>Pay Unit</i>
Topsoiling, 4" Thick (Item 40)	Square Yard

SECTION 806 – FERTILIZING AND SEEDING

806.04 MEASUREMENT AND PAYMENT

THE ENTIRE SECTION IS CHANGED TO:

Measurement and payment for fertilizing and seeding shall be made under the item, FERTILIZING AND SEEDING. Fertilizing and seeding required for grass restoration as a result of grass areas disturbed by construction operations such as foundations, conduit runs, junction boxes, curb, sidewalk or for demolished items shall not be included under this pay item. Payment for restoration in these areas shall be included as part of their respective construction items.

Payment will not be made for areas of fertilizing and seeding disturbed by Construction Operations, beyond the prescribed grading limits.

Measurement and Payment will be as follows:

<i>Item</i>	<i>Pay Unit</i>
Fertilizing and Seeding, Type A-3 (Item 41)	Square Yard

SECTION 809 – MULCHING

809.04 MEASUREMENT AND PAYMENT

THE ENTIRE SECTION IS CHANGED TO:

Measurement and payment for mulching shall be made under the item, STRAW MULCHING. Mulching required for grass restoration as a result of grass areas disturbed by construction operations such as foundations, conduit runs, junction boxes, curb, sidewalk or for demolished items shall not be included under this pay item. Payment for restoration in these areas shall be included as part of their respective construction items.

Payment will not be made for areas of mulching disturbed by Construction Operations, beyond the prescribed grading limits.

Measurement and Payment will be as follows:

<i>Item</i>	<i>Pay Unit</i>
Straw Mulching (Item 42)	Square Yard

PLANS FOR
**INTERSECTION IMPROVEMENTS AT
 CHESTNUT STREET (CR 625) AND
 FIFTH AVENUE**
 BOROUGH OF ROSELLE, UNION COUNTY, NEW JERSEY

CONTRACT No. 2016-020

UTILITY OWNERS
THE BOROUGH OF ROSELLE DEPARTMENT OF PUBLIC WORKS 210 CHESTNUT STREET ROSELLE, NJ 07203 ATTN: LOU WILLIAMS (908) 245-2920
NJ AMERICAN WATER 1341 NORTH AVENUE PLAINFIELD, NJ 07061 ATTN: SCOTT SCHREIBER (908) 791-3464
COMCAST OF NEW JERSEY 900 RAHWAY AVENUE UNION, NJ 07083 ATTN: BOB KNOEPHEL (908) 378-0256
VERIZON COMMUNICATIONS 175 W MAIN STREET 1ST FLOOR FREEHOLD, NJ 07728 ATTN: BILL SCHNEIDER (908) 251-4889
PSE&G 472 WESTON CANAL ROAD SOMERSET, NJ 08873 ATTN: MICHELLE STILES (732) 764-3161
ELIZABETHTOWN GAS COMPANY 520 GREEN LANE UNION, NJ 07083 ATTN: GREGG BALINT (908) 662-8321
LOCATION OF UTILITIES SHOWN ON THESE PLANS ARE NOT WARRANTED AS TO EXACTNESS. CONTRACTOR SHALL DETERMINE EXACT LOCATION AND DEPTH OF UTILITIES PRIOR TO CONSTRUCTION IN ACCORDANCE WITH THE REQUIREMENTS OF THE CONTRACT DOCUMENTS AND OTHER APPLICABLE LAWS.
PRIOR TO DIGGING CALL 1-800-272-1000

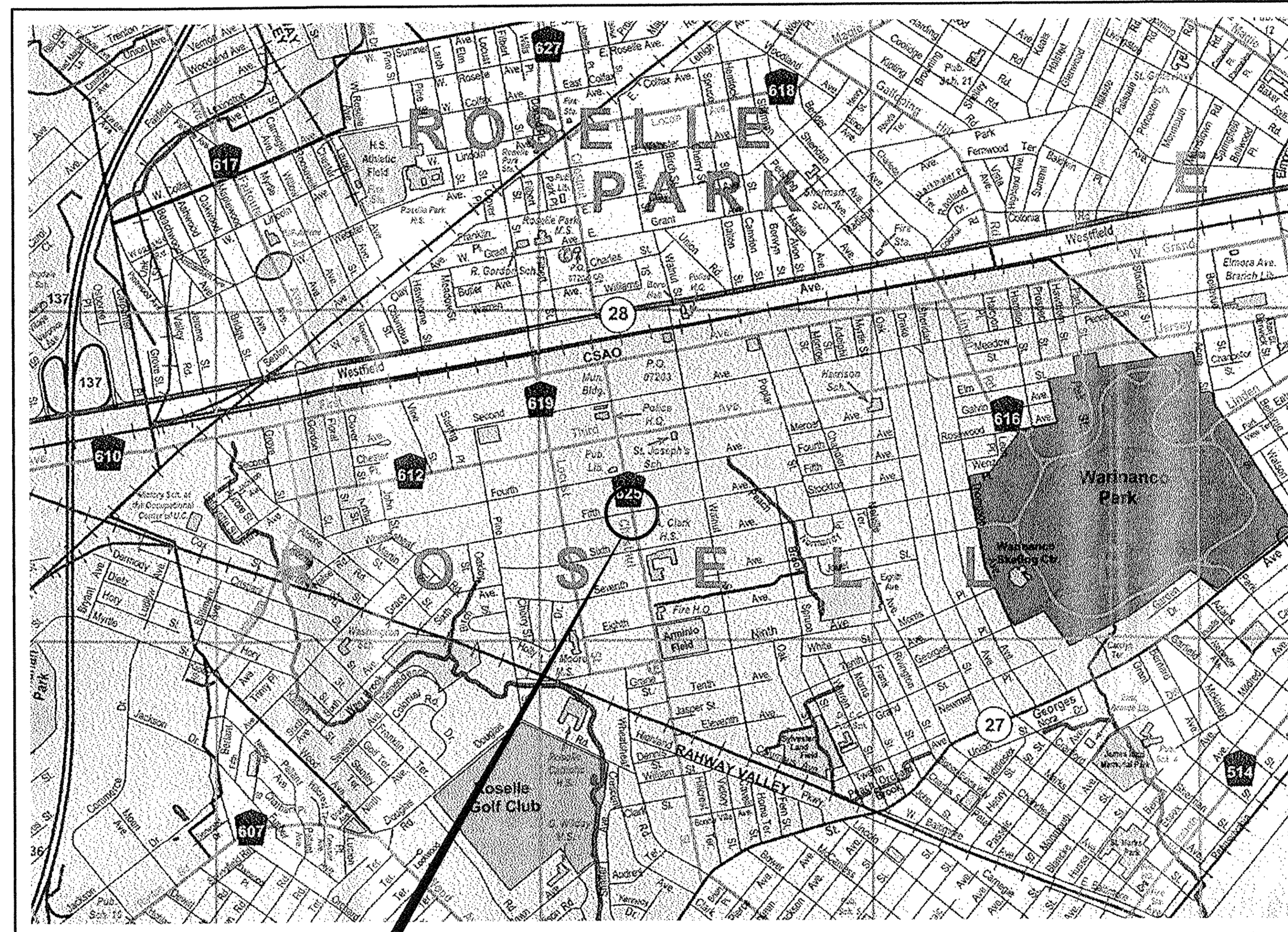

PROJECT SITE
 BOROUGH OF ROSELLE
 CHESTNUT STREET (CR 625)
 AND FIFTH AVENUE

KEY MAP
 SCALE: 1" = 2,000'

PREPARED BY



11 TINDALL ROAD
 MIDDLETOWN, NJ 07748
 TEL: 732-671-9400
 FAX: 732-671-7355
 www.landmarksocial.com

NEW JERSEY BOARD OF PROFESSIONAL ENGINEERS
 AND LAND SURVEYORS
 CERTIFICATE OF AUTHORIZATION 24627987500

BRUCE P. KLEIN, P.E.
 CONSULTING ENGINEER

Bruce Klein 4/7/17
 REGISTERED PROFESSIONAL ENGINEER DATE:
 N.J. LICENSE NO. GE47391

INDEX OF SHEETS	
Sheet Number	Sheet Title
1	COVER SHEET
2	ESTIMATE AND DISTRIBUTION OF QUANTITIES
3	LEGEND AND GENERAL NOTES
4-6	TRAFFIC CONTROL DETAILS
7	CONSTRUCTION PLAN
8	GRADING PLAN
9	TRAFFIC SIGNAL, SIGNING AND STRIPING PLAN
10-11	ELECTRICAL PLANS
12-19	CONSTRUCTION DETAILS
20-31	ELECTRICAL DETAILS

THE NEW JERSEY DEPARTMENT OF TRANSPORTATION "STANDARD ROADWAY CONSTRUCTION/TRAFFIC CONTROL/BRIDGE CONSTRUCTION DETAILS" BOOKLET DATED (2007) AND "ELECTRICAL BUREAU STANDARD DETAILS" (2007) TO GOVERN, EXCEPT FOR THOSE DETAILS CONTAINED HEREIN.

THE 2007 U.S. CUSTOMARY ENGLISH UNITS STANDARD SPECIFICATIONS FOR ROAD AND BRIDGE CONSTRUCTION, OF THE NEW JERSEY DEPARTMENT OF TRANSPORTATION, AS AMENDED OR SUPPLEMENTED HEREIN, SHALL GOVERN IN THE CONSTRUCTION OF THIS PROJECT.

<i>AF</i>	4/12/17
APPROVED BY ALFRED J. FAELLA, Union County Manager	DATE
<i>Tom Mineo</i>	4/12/17
RECOMMENDED BY THOMAS O. MINEO, P.E., Union County Engineer	DATE
<i>Christine Dansereau</i>	4/12/17
RECOMMENDED BY CHRISTINE DANSEREAU, Borough of Roselle, Mayor	DATE
<i>Carl P. O'Brien</i>	4/12/17
RECOMMENDED BY CARL O'BRIEN, P.E., Borough of Roselle, Engineer	DATE

STANDARD LEGEND

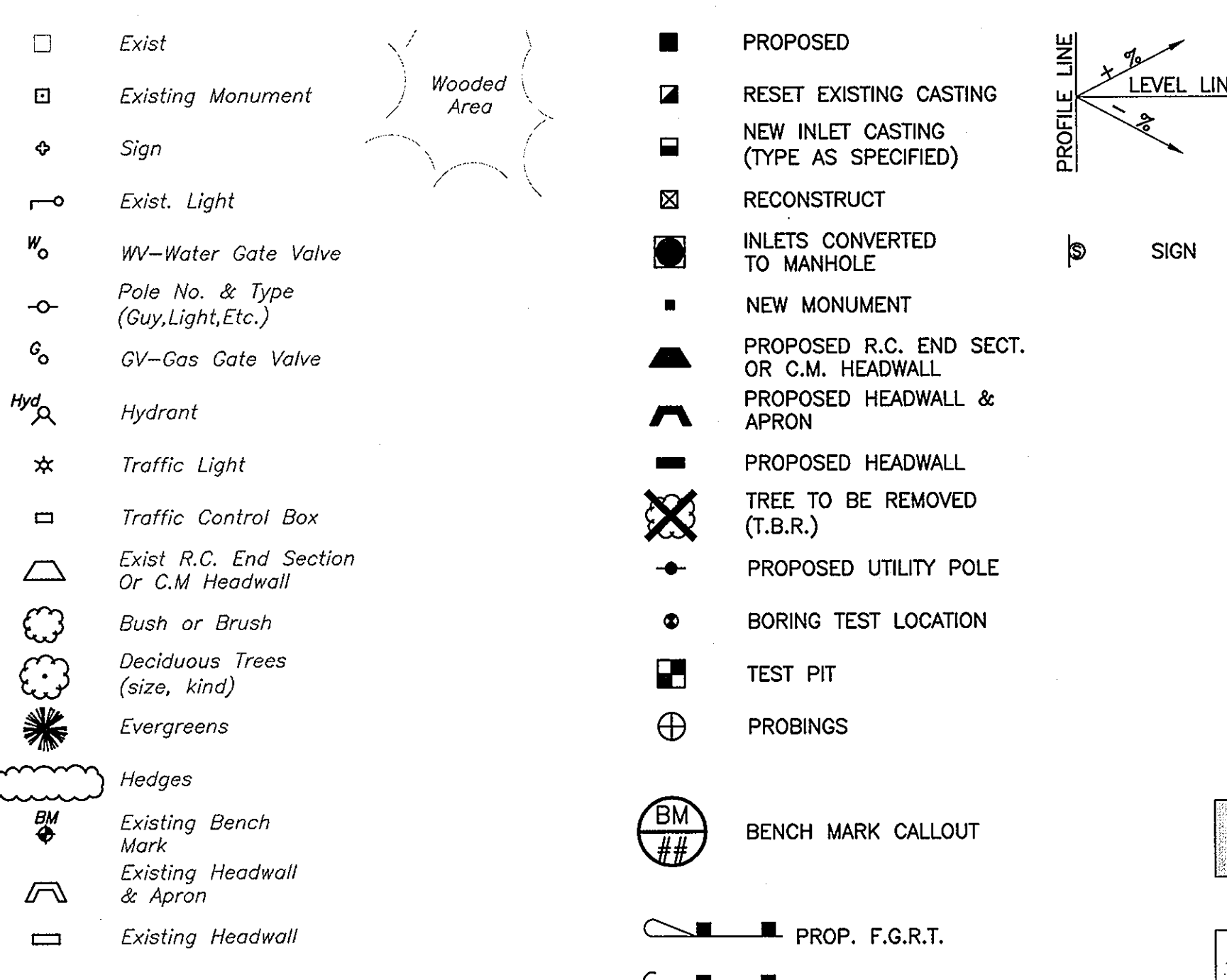
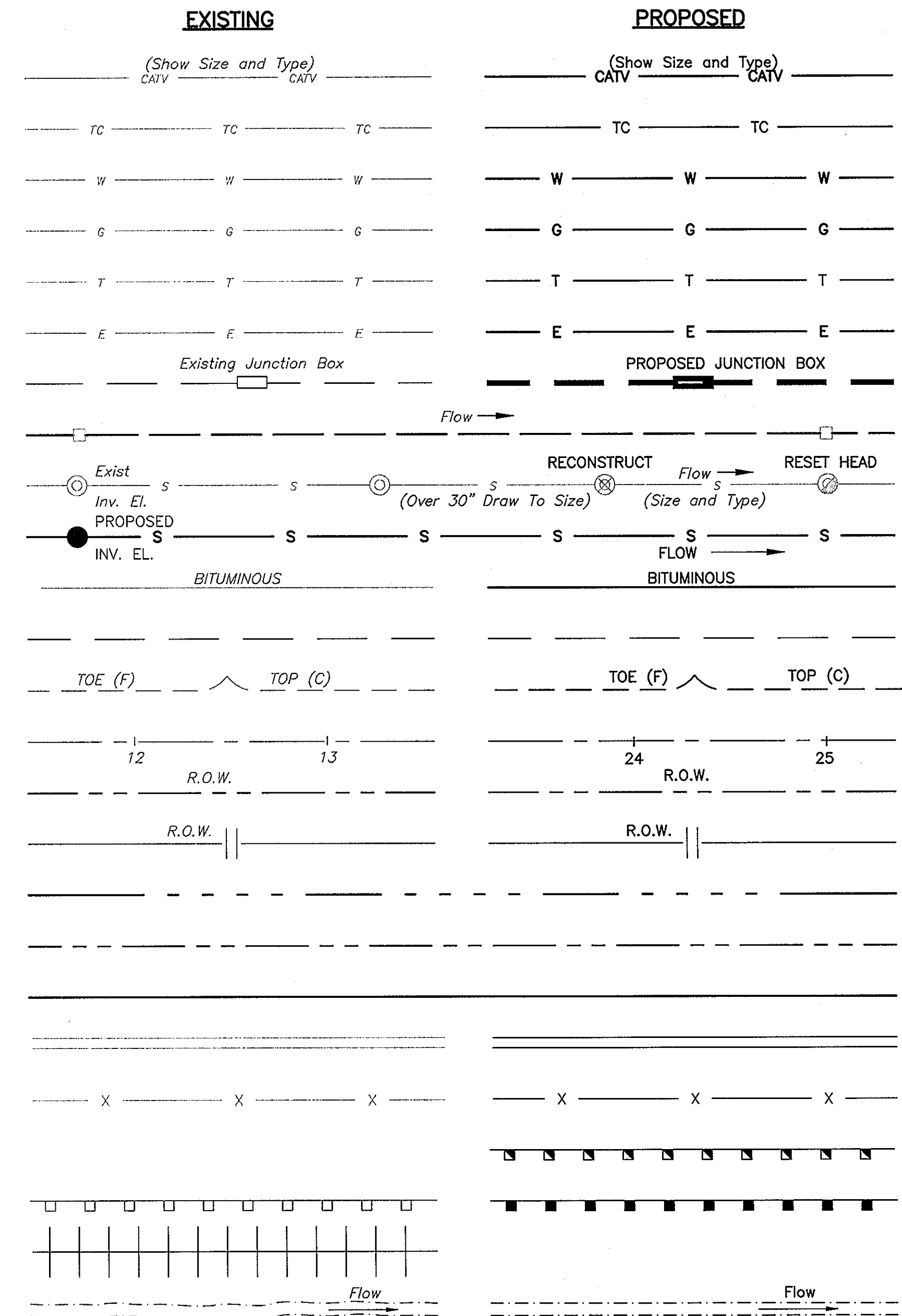
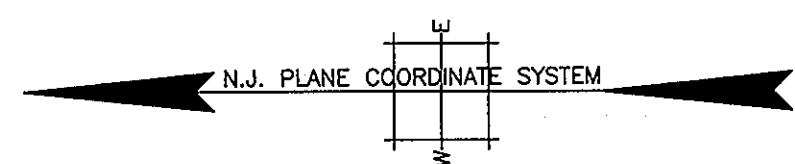

CABLE TELEVISION
TELECOMMUNICATION CONDUIT
WATER MAIN
GAS MAIN
TELEPHONE CONDUIT
ELECTRIC CONDUIT
ELECTRIC CONDUIT, HIGHWAY
EXISTING STORM DRAINS
EXISTING SANITARY SEWERS
PROPOSED SANITARY SEWERS AND STORM DRAINS (ONLY IN SPECIAL CASES DRAW TO SIZE)
EDGE OF PAVEMENT (BITUMINOUS, CONCRETE)
SHOULDERS
SLOPES
CENTERLINE, BASELINE AND TRAVERSE LINE
RIGHT OF WAY LINES
ACCESS PERMITTED
NO ACCESS
TOWNSHIP, CITY, COUNTY LINE
PROPERTY LINES
WETLANDS LINE
CURBS
FENCES
RESET BEAM GUIDE RAIL
BEAM GUIDE RAIL
RAILROAD
REPRESENTS BOTTOM OF DITCH OR CREEK
INLETS (TYPE AS INDICATED)

ABBREVIATIONS:

A.D.	ALGEBRAIC DIFFERENCE	GUT	GUTTER	PVI	POINT OF VERTICAL INTERSECTION
ACC	ASPHALT CEMENT CONCRETE	GV	GAS VALVE	PVT	POINT OF VERTICAL TANGENCY
ACI	AMERICAN CONCRETE INSTITUTE	H.P.	HIGH POINT	R	RADIUS
ADA	AMERICANS WITH DISABILITIES ACT	HC, HCR	HANDICAP RAMP	R.C.E.S.	REINFORCED CONCRETE END SECTION
AGG.	AGGREGATE	HMA	HOT MIX ASPHALT	R.O.W.	RIGHT OF WAY
ANSI	AMERICAN NATIONAL STANDARDS INSTITUTE	HORIZ	HORIZONTAL	R.R.S.P.	RIP RAP STONE PROTECTION
APPROX.	APPROXIMATE, APPROXIMATELY	HP	HIGH POINT	RCCP	REINFORCED CONCRETE CULVERT PIPE
ASTM	AMERICAN SOCIETY FOR TESTING AND MATERIALS	IN	INCHES	RCES	REINFORCED CONCRETE END SECTION
AVG.	AVERAGE	INV	INVERT	RCP	REINFORCED CONCRETE PIPE
B	BOTTOM	JCP&L	JERSEY CENTRAL POWER & LIGHT	ROAD	ROAD
BCT	BREAKAWAY CABLE TERMINAL	K	RATE OF VERTICAL CURVATURE	REIN.	REINFORCED
BIT	BITUMINOUS	L.O.M.	LIMIT OF MILLING	RF	REAR FACE
B	BENCHMARK	L.O.P.	LIMIT OF PAVING	RMC	RIGID METALLIC CONDUIT
BM	BENCHMARK	L.P.	LOW POINT	RNMC	RIGID NONMETALLIC CONDUIT
BO	BOTTOM OF	LF	LINEAR FEET	ROW	RIGHT OF WAY
BW, BOW	BOTTOM OF WALL	LOD	LIMIT OF DISTURBANCE	RPM	RAISED PAVEMENT MARKER
C	CUT	LOM	LIMIT OF MILLING	RT	RIGHT
COC	CENTER OF CURVE	LP	LOW POINT	S	SOUTH
C.R.	COUNTY ROUTE	LC	LOCKING COVER	S.C.F.	SEDIMENT CONTROL FENCE
CRV. CTR.	CURVE CENTER	LF	LINEAR FEET	S.O.D.	SUBBASE OUTLET DRAIN
CC, C TO C	CENTER-TO-CENTER	LOD	LIMIT OF DISTURBANCE	SB	SOUTHBOUND
CCA	CHROMATED COPPER ARSENATE	LOP	LIMIT OF PAVING	SCD	SOIL CONSERVATION DISTRICT
CF	CUBIC FEET	LP	LOW POINT	SE	SOUTHEAST
CFS	CUBIC FEET PER SECOND	LS	LUMP SUM	SF	SQUARE FEET
CIP	CAST IN PLACE, CAST IRON PIPE	LT	LEFT	SHLDR	SHOULDER
CJ	CONTROL JOINT	MAX	MAXIMUM	SHT	SHEET
CL	CENTERLINE	MH	MANHOLE	SHWT	SEASONAL HIGH WATER TABLE
CLF	CHAIN LINK FENCE	MHHW	MEAN HIGH HIGH WATER	Sl&A	STRUCTURE INVENTORY AND APPRAISAL
CMP	CORRUGATED METAL PIPE	MHW	MEAN HIGH WATER	SOD	SUBBASE OUTLET DRAIN
COE	U.S. ARMY CORPS OF ENGINEERS	MIN	MINIMUM	SO	SQUARE
CONC	CONCRETE	MLLW	MEAN LOW LOW WATER	STA	STATION
COV.	COVER	MLW	MEAN LOW WATER	STAB	STABILIZED
CP	COUNTY ROUTE	MP	MIDPOINT	SURF	SURFACE
CR	COUNTY ROUTE	MPH	MILES PER HOUR	SW	SOUTHWEST
CRSE	COURSE	MPT	MAINTENANCE AND PROTECTION OF TRAFFIC	SW, SDWK	SIDEWALK
CY	CUBIC YARDS	MUTCD	MANUAL ON UNIFORM TRAFFIC CONTROL DEVICES	SY	SQUARE YARDS
DC	DEPRESSED CURB	N	NORTH, NUMBER	T	TOP, TELEPHONE
DEP, NJDEP	NEW JERSEY DEPARTMENT OF	NAD	NORTH AMERICAN DATUM	T.B.R.	TO BE REMOVED
DGA	DENSE GRADED AGGREGATE	NAV	NORTH AMERICAN VERTICAL DATUM	T.G.	TOP OF GRATE
DIA	DIAMETER	NB	NORTHBOUND	TAN	TANGENT
DIP	DUCTILE IRON PIPE	NE	NORTHEAST	TBA	TO BE ABANDONED
DOT, NJDOT	NEW JERSEY DEPARTMENT OF TRANSPORTATION	NGVD	NATIONAL GEODETIC VERTICAL DATUM	TBR	TO BE REMOVED
DWS	DETECTABLE WARNING SURFACE	NTS	NOT TO SCALE	TC	TOP OF CURB
DWY	DRIVEWAY	NW	NORTHWEST	TEMP	TEMPORARY
E	EAST	OC	ON CENTER	TG	TOP OF GRATE
E.C.	EAST OF CONCRETE	P	PROPERTY LINE	THK	THICK
EB	EASTBOUND	P.G.L.	PROFILE GRADE LINE	TO	TOP OF
EC	EDGE OF CONCRETE, EPOXY COATED	PAVT, PVMT	PAVEMENT	TS	TOPSOIL
EF	EACH FACE	PC	POINT OF CURVATURE	TW, TOW	TOP OF WALL
EL, ELEV	ELEVATION	PCC	POINT OF COMPOUND CURVATURE,	TYP	TYPICAL
EP	EDGE OF PAVEMENT	PE	PROFESSIONAL ENGINEER	U.E.H.	USE EXISTING HEAD
EX, EXIST	EXISTING	PED	PEDESTRIAN	UN	UNIT
EXP JT	EXPANSION JOINT	PGL	PROFILE GRADE LINE	UP	UTILITY POLE
F	FILL	PI	POINT OF INTERSECTION	VAR	VARIABLE
FEMA	FEDERAL EMERGENCY MANAGEMENT AGENCY	PK	PROPERTY NAIL	VC	VERTICAL CURVE
FERT	FERTILIZER, FERTILIZING	PL	PROPERTY LINE	VERT	VERTICAL
FF	FRONT FACE	POL	POINT ON LINE	VMS	VARIABLE MESSAGE SIGN
FNMC	FLEXIBLE NONMETALLIC CONDUIT	PP	PETROLEUM PIPELINE	W	WATER, WEST
FO	FIBER OPTIC	PROP	PROPOSED	WB	WESTBOUND
FTG	FOOTING	PROWAG	PROPOSED ACCESSIBILITY GUIDELINES	WP	WORKING POINT
G	GAS	PSE&G	PUBLIC SERVICE ELECTRIC AND GAS	WS	WATER SURFACE
GIS	GEOGRAPHIC INFORMATION SYSTEM	PSF	POUNDS PER SQUARE FOOT	WSE, WSEL	WATER SURFACE ELEVATION
GPS	GLOBAL POSITIONING SYSTEM	PSI	POUNDS PER SQUARE INCH	WV	WATER VALVE
GR, GRT	GRATE	PT	POINT OF TANGENCY	WWM	WELDED WIRE MESH
GRD	GRADE, GRADED	PVC	POINT OF VERTICAL CURVATURE		

GENERAL NOTES

- HORIZONTAL DATUM IS IN THE NEW JERSEY PLANE COORDINATE SYSTEM, NORTH AMERICAN DATUM 1983.
- ELEVATIONS REFER TO THE NORTH AMERICAN VERTICAL DATUM, 1988. NGVD 1929 = NAVD 1988 + 1.08'
- ALL DIMENSIONS, UNITS, ETC. ARE IN THE U.S. CUSTOMARY SYSTEM.
- THE CONTRACTOR SHALL PROTECT ALL SURVEY CONTROL POINT MARKS FROM DAMAGE AND SHALL ESTABLISH OFFSET POINTS AS REQUIRED FOR ITS WORK.
- LOCATIONS OF EXISTING AND PROPOSED UTILITIES ARE APPROXIMATE. IT IS THE CONTRACTOR'S RESPONSIBILITY TO DETERMINE ALL UTILITY LOCATIONS IN THE FIELD PRIOR TO EXCAVATION.
- ALL SOIL EROSION CONTROL MEASURES SHALL BE IN PLACE PRIOR TO GROUND DISTURBANCE.
- DEPRESSED CURBS AT HANDICAPPED RAMPS/CROSSWALKS SHALL BE FLUSH WITH THE PAVEMENT SURFACE. DEPRESSED CURBS AT DRIVEWAYS SHALL HAVE A 1 1/2" CURB FACE.
- ALL TRAFFIC CONTROL DEVICES SHALL CONFORM WITH THE CURRENT MANUAL ON UNIFORM TRAFFIC CONTROL DEVICES.
- ONLY PAY ITEMS LISTED IN THE PROPOSAL ARE APPLICABLE TO THIS PROJECT. PAY ITEMS NOT IN THE PROPOSAL WILL NOT BE USED.
- NO SEPARATE PAYMENT SHALL BE MADE TO SAWCUT EXISTING PAVEMENT, DRIVEWAYS, OR SIDEWALKS. INCLUDE ALL COSTS IN THE VARIOUS ITEMS IN THE PROPOSAL.
- THE CONTRACTOR SHALL PRESERVE AND PROTECT ALL PROPERTY CORNERS DURING CONSTRUCTION. ANY PROPERTY CORNERS DISTURBED SHALL BE RESET AT THE EXPENSE OF THE CONTRACTOR.
- THE CONTRACTOR SHALL CONTACT THE UTILITY COMPANIES TO COORDINATE ANY WORK THAT MAY NEED TO BE CONDUCTED WITHIN THE PROJECT LIMITS.
- THE CONTRACTOR SHALL MAINTAIN EXISTING DRAINAGE PATTERNS ON ROADWAYS, IN YARDS, AND PRIVATE PROPERTIES ALONG PROPOSED PAVEMENT AND SIDEWALK INSTALLATIONS.
- HEDGES, BUSHES, LANDSCAPE TIES, STONE EDGING, SIGNS, LANDSCAPE MATERIAL, FENCES, AND EDGING MATERIAL FOR DRIVEWAYS AND SIDEWALKS SHALL BE RESET OR REPLACED AS DIRECTED BY THE ENGINEER. NO SEPARATE PAYMENT SHALL BE MADE. INCLUDE ALL COSTS IN THE VARIOUS ITEMS IN THE PROPOSAL.
- ALL TREES ADJACENT TO OR WITHIN THE LIMITS OF WORK ARE NOT TO BE DISTURBED UNLESS OTHERWISE DIRECTED BY THE ENGINEER. THE CONTRACTOR SHALL PROTECT TREES DURING ALL CONSTRUCTION RELATED ACTIVITIES.
- THE CONTRACTOR IS RESPONSIBLE FOR MAKING HIS OWN DETERMINATIONS AS TO THE TYPE AND LOCATION OF UNDERGROUND UTILITIES AS MAY BE NECESSARY TO AVOID DAMAGE THERETO. UTILITY LOCATIONS SHOWN ON THE PLANS ARE APPROXIMATE. IT IS THE RESPONSIBILITY OF THE CONTRACTOR TO VERIFY ALL LOCATIONS PRIOR TO CONSTRUCTION. ALL EXISTING UTILITIES MUST BE MAINTAINED AND KEPT OPERATIONAL AT ALL TIMES DURING CONSTRUCTION EXCEPT AS AUTHORIZED BY THE UTILITY COMPANY. ALL EXISTING UNDERGROUND AND OVERHEAD UTILITIES MUST BE PROTECTED FROM DAMAGE AT ALL TIMES. THE CONTRACTOR SHALL BE RESPONSIBLE TO SUPPORT UTILITY POLES ADJACENT TO EXCAVATION AREAS UNTIL THE AREAS ARE BACKFILLED AND STABILIZED.
- CONTRACTOR IS RESPONSIBLE FOR SURVEYING ALL ELEVATIONS NECESSARY FOR THE INSTALLATION OF CONCRETE CURB RAMPS AND SHALL RECEIVE APPROVAL FROM THE ENGINEER PRIOR TO PLACEMENT OF ANY CONCRETE. ANY RAMPS PLACED WITHOUT SUCH APPROVAL AND WHICH ARE NOT ADA COMPLIANT SHALL BE REPLACED AT CONTRACTOR'S EXPENSE.
- ALL WORK SHALL BE PERFORMED IN ACCORDANCE WITH THE 2007 NJDOT STANDARD SPECIFICATIONS FOR ROAD AND BRIDGE CONSTRUCTION, AS AMENDED HEREIN.
- ALL WORK IS TO BE PERFORMED IN ACCORDANCE WITH THE STANDARDS FOR SOIL EROSION AND SEDIMENT CONTROL IN NEW JERSEY.
- TOPOGRAPHIC AND EXISTING FEATURES ARE BASED ON GROUND SURVEY.
- ALL SOIL EROSION CONTROL MEASURES SHALL BE IN PLACE PRIOR TO GROUND DISTURBANCE AND IN ACCORDANCE WITH THE CURRENT STANDARDS FOR SOIL EROSION AND SEDIMENT CONTROL IN NEW JERSEY.
- MATERIAL EXCAVATED FROM PAVEMENT AREAS SHALL BE REPLACED WITH PAVING MATERIAL AND COMPACTED THAT SAME DAY.
- TRAFFIC SHALL BE MAINTAINED AT ALL TIMES DURING CONSTRUCTION IN ACCORDANCE WITH THE CURRENT MANUAL ON UNIFORM TRAFFIC CONTROL DEVICES AND TYPICAL NJDOT PROCEDURES.

HATCH PATTERNS

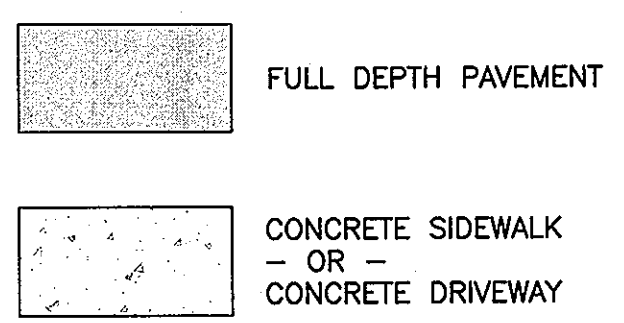

NO.	DATE	REVISIONS	BY

BRUCE P. KLEIN, P.E.
 CONSULTING ENGINEER
 04-07-2017
 LICENSED PROFESSIONAL ENGINEER
 STATE OF NJ LICENSE NO. GE47991















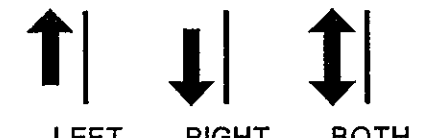

BOROUGH OF ROSELLE
INTERSECTION IMPROVEMENTS AT CHESTNUT STREET (CR 625) AND FIFTH AVENUE
 BOROUGH OF ROSELLE, UNION COUNTY, NEW JERSEY
LEGEND AND GENERAL NOTES

AND
YOUR GOALS. OUR MISSION.
 11 TINDALL ROAD
 MIDDLETOWN, NJ 07748
 TEL 732-671-8400
 FAX 732-671-7365
 www.andassociates.com
 NEW JERSEY BOARD OF PROFESSIONAL ENGINEERS AND LAND SURVEYORS
 CERTIFICATE OF AUTHORIZATION 24027817500
 OFFICES LOCATED IN:
 DELAWARE, INDIANA, KENTUCKY,
 MASSACHUSETTS, MICHIGAN, NEW JERSEY,
 OHIO AND PENNSYLVANIA

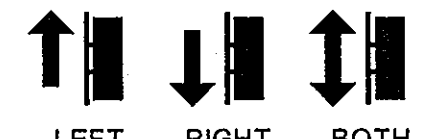
DESIGNED BY	IK	DRAWING	LEG-1
CHECKED BY	BPK	SHEET	3
DRAWN BY	IK	DATE	APRIL 2017
SCALE	NONE	PROJ. NO.	UNC000680
OF	31		

PROJECT INFORMATION: UNCLE SAM'S...
 FILE NAME: UNCLE SAM'S...
 LAST SAVED DATE AND TIME: 23 Apr 2017, 2:38PM
 LAST SAVE BY: bpk
 COPYRIGHT 2017, TAM ASSOCIATES, INC. ALL RIGHTS RESERVED. THE COPYING OR REUSE OF THIS DOCUMENT WITHOUT THE WRITTEN PERMISSION OF TAM ASSOCIATES IS PROHIBITED.

LEGEND

-  BREAKAWAY BARRICADES
-  BREAKAWAY BARRICADES WITH SIGN
-  CONSTRUCTION SIGNS
-  DRUMS
-  CONE
-  PRECAST CONCRETE CURB CONSTRUCTION BARRIER (TYPE SPECIFIED)
-  DIRECTION OF TRAFFIC FLOW
-  TRAFFIC DIRECTOR, FLAGGER
-  TRAILER MOUNTED MOUNTED ARROW BOARD SHOWING CAUTION MODE
-  ILLUMINATED FLASHING ARROW MOUNTED ON TOWING VEHICLE SHOWING ARROW PATTERN (Left, Right, Both)
-  TRAFFIC CONTROL TRUCK WITH MOUNTED CRASH CUSHION AND ARROW BOARD SHOWING CAUTION MODE
-  TRAFFIC CONTROL TRUCK WITH MOUNTED CRASH CUSHION AND ARROW BOARD SHOWING ARROW PATTERN (Left, Right, Both)
-  TEMPORARY CRASH CUSHION, INERTIAL BARRIER SYSTEM
-  TEMPORARY CRASH CUSHION, (all other approved)
-  BUFFER ZONE
-  WORK AREA
-  PAINT STRIPING TRUCK OR OTHER OPERATING VEHICLE

GENERAL NOTES:

1. ADVANCE WARNING SIGNS, DISTANCES, AND TAPER LENGTHS MAY BE EXTENDED, AT DIRECTION OF THE ENGINEER, TO ADJUST FOR REDUCED VISIBILITY DUE TO HORIZONTAL AND VERTICAL CURVATURE OF THE ROADWAY.
2. PRIOR TO ANY ROAD CONSTRUCTION, TRAFFIC CONTROL SIGNS AND DEVICES SHALL BE IN PLACE.
3. RAMPS AND/OR SIDE STREETS ENTERING THE ROADWAY AFTER THE FIRST ADVANCE WARNING SIGN SHALL BE PROVIDED WITH AT LEAST ONE W20-IF SIGN (ROAD WORK AHEAD) AS A MINIMUM.
4. ALL EXISTING ROAD SIGNS, PAVEMENT MARKINGS AND/OR PLOWABLE PAVEMENT REFLECTORS WHICH CONFLICT WITH THE PROPOSED TRAFFIC CONTROL PLAN SHALL BE COVERED, REMOVED OR RELOCATED AS DIRECTED BY THE ENGINEER.
5. CONFLICTING OR NON-OPERATING SIGNAL INDICATIONS ON EITHER THE EXISTING, INTERIM, OR PROPOSED TRAFFIC SIGNAL SYSTEMS SHALL BE BAGGED OR COVERED.
6. MAINTENANCE AND PROTECTION OF TRAFFIC SHALL BE IN ACCORDANCE WITH THE MANUAL OF UNIFORM TRAFFIC CONTROL DEVICES - PART VI "STANDARDS AND GUIDES FOR TRAFFIC CONTROL FOR STREET AND HIGHWAY CONSTRUCTION, MAINTENANCE, UTILITY, AND INCIDENT MANAGEMENT OPERATIONS", UNLESS OTHERWISE NOTED IN THE PLANS AND SPECIFICATIONS, AND SHALL BE APPROVED BY THE ENGINEER.
7. THE CONTRACTOR SHALL SUBMIT A PLAN FOR THE SAFE ACCESS OF CONSTRUCTION VEHICLES THROUGHOUT THE WORK SITE WHERE SPACE CONSTRAINTS PREVENT THE USE OF LANE CLOSURES. THE PLAN SHALL BE SUBMITTED TO THE ENGINEER IN ACCORDANCE WITH SECTION 159 OF THE STANDARD SPECIFICATIONS.
8. TRAFFIC SAFETY SERVICES SHALL BE USED IN ACCORDANCE WITH THE STANDARD SPECIFICATIONS FOR TRAFFIC CONTROL, SECTION 159.
9. ALL EXCAVATED AREAS WITHIN OR ADJACENT TO THE ROADWAY SHALL BE BACKFILLED AND PLACED ON A MINIMUM 6H : 1V SLOPE PRIOR TO THE END OF EACH WORK DAY. OTHER EXCAVATED AREAS WITHIN THE CLEAR ZONE ARE TO BE EITHER BACKFILLED OR A PRECAST CONCRETE CURB CONSTRUCTION BARRIER SET TEMPORARILY IN PLACE TO SHIELD VEHICULAR AND PEDESTRIAN TRAFFIC.
10. WHERE REQUIRED, THE CONTRACTOR SHALL MAKE PROVISIONS FOR MAINTAINING PEDESTRIAN CROSSING LOCATIONS AND TYPE AS DIRECTED BY THE ENGINEER.
11. TRAFFIC CONTROL DEVICES FOR LANE CLOSURES INCLUDING SIGNS, CONES, BARRICADES, ETC. SHALL BE PLACED PER THE APPROVED TRAFFIC CONTROL PLAN SUBMITTED BY THE CONTRACTOR, PER SPECIFICATION 159.03.01. SIGNS SHALL NOT BE PLACED WITHOUT ACTUAL LANE CLOSURES AND SHALL BE IMMEDIATELY REMOVED UPON REMOVAL OF THE CLOSURES.
12. CONES MAY BE SUBSTITUTED FOR DRUMS AND INSTALLED UPON THE APPROVAL OF THE ENGINEER.

REGULATORY APPROACH SPEED OF TRAFFIC MILES/HOUR	RECOMMENDED TAPER LENGTH AND SPACING FOR CHANNELIZING TAPERS			RECOMMENDED SPACING ALONG TANGENTS	
	MINIMUM TAPER RATIO IN LENGTH PER FOOT OF WIDTH	MINIMUM TAPER LENGTH L - FOR LANE WIDTHS		MAXIMUM DEVICE (B) SPACING ALONG TAPERS IN FEET	MAXIMUM DEVICE (D) SPACING ALONG TANGENTS IN FEET
25	10.5:1	10'	11'	25	50
30	15:1	150	165	30	60
35	20.5:1	205	225	35	70
40	27:1	270	300	40	80
45	45:1	450	495	45	90
50	50:1	500	550	50	100
55	55:1	550	605	55	110
60	60:1	600	660	60	120
65	65:1	650	715	65	130

NOTE:
THE MAXIMUM DEVICE SPACING ALONG CURVES SHALL BE AS DEFINED FOR TAPERS (B) IN THE ABOVE TABLE.

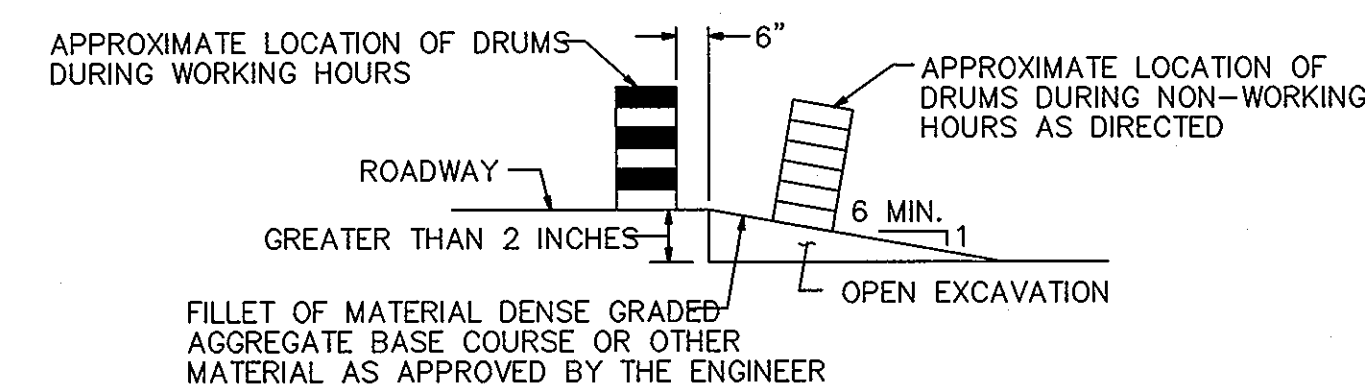

NOTE:
ESCAPE RAMPS MUST BE CONSTRUCTED AND MAINTAINED DURING NON-WORKING HOURS WHERE A VERTICAL DROP GREATER THAN 2 INCHES EXISTS ADJACENT TO TRAVELED LANE.

ESCAPE RAMP DETAIL

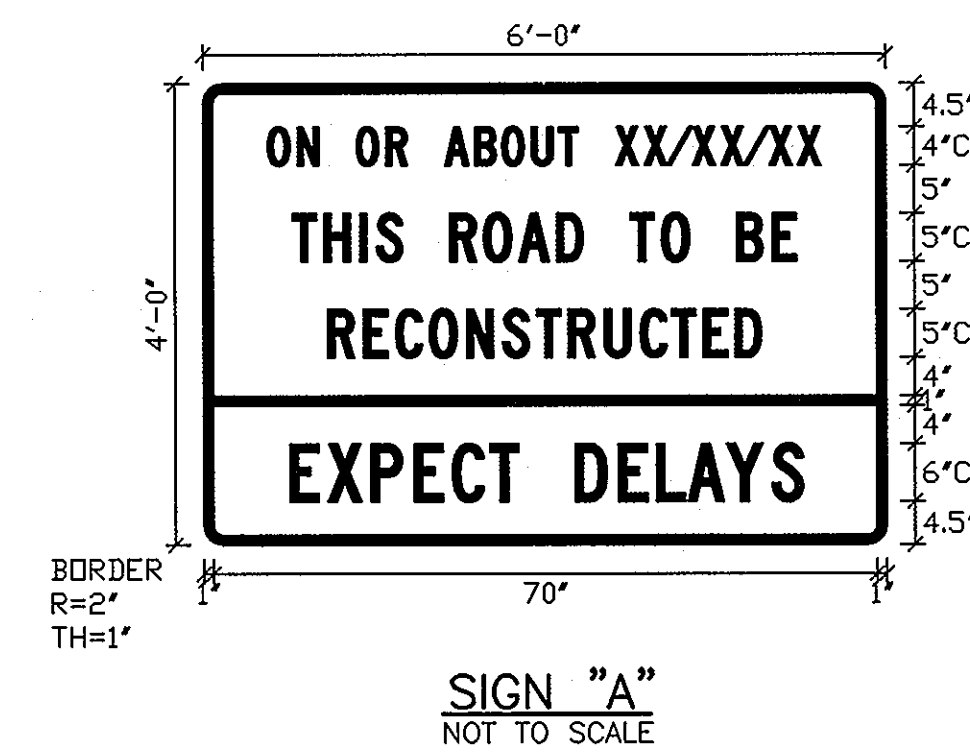

SIGN "A"
NOT TO SCALE

SEQUENCE OF CONSTRUCTION

STAGE 1

1. INSTALLATION OF TRAFFIC CONTROL DEVICES SHALL BE IN ACCORDANCE WITH MUTCD STANDARDS.
2. SITE CLEARING OF AREAS WHERE ROADWAYS AND IMPROVEMENTS ARE PROPOSED.
3. CONSTRUCTION OF PROPOSED TRAFFIC SIGNAL EQUIPMENT.
5. CONSTRUCTION OF ALL PROPOSED CURBS AND SIDEWALKS.
6. CONSTRUCTION OF EXCAVATION, DENSE GRADED AGGREGATE AND HOT MIX ASPHALT BASE COURSES.

STAGE 2

1. INSTALLATION OF PERMANENT SIGNS AND STRIPING.
2. OPERATE SIGNAL SYSTEMS UPON APPROVAL OF INSTALLATION.
3. REMOVE ALL CONSTRUCTION SIGNS AND OTHER MAINTENANCE DEVICES.

SIGN DESIGNATION	MESSAGE	SIZE IN. x IN.	AREA IN SQ. FT.	REQUIRED QUANTITY IN NUMBER	TOTAL AREA IN SQ. FT.
G20-2A	END ROAD WORK	48x24	8.0	4	32.00
W1-6(L or R)	LEFT or RIGHT LARGE ARROW	48x24	8.0	18	144.00
W1-4(aL or aR)	LEFT or RIGHT MERGE SYMBOL	48x48	16.0	4	64.00
W5-1(S)	ROAD NARROWS	48x48	16.0	4	64.00
W20-1(A)	ROAD WORK 1500 FT	48x48	16.0	4	64.00
W20-1(D)	ROAD WORK 1/2 MILE	48x48	16.0	4	64.00
W20-1(F)	ROAD WORK AHEAD	48x48	16.0	4	64.00
SIGN 'A'	ON OR ABOUT XX/XX/XXXX THIS ROAD TO BE RECONSTRUCTED EXPECT DELAYS	72X48	24.0	4	96.00
CONSTRUCTION SIGN TOTAL					592.00

PROJECT INFORMATION:
 FILE PATH: H:\UNICO\06850\Plans\...
 LAST SAVED DATE AND TIME: 12 Apr 2017, 11:29AM
 LAST SAVE BY: Itob

COPYRIGHT 2017, I&M ASSOCIATES, ALL RIGHTS RESERVED. THE COPYING OR REUSE OF THIS DOCUMENT FOR ANY PURPOSE, OR THE PURPOSE, ORIGINALLY INTENDED, WITHOUT THE WRITTEN PERMISSION OF I&M ASSOCIATES IS PROHIBITED.

NO.	DATE	REVISIONS	BY	CHKD

BRUCE P. KLEIN, P.E.
 CONSULTING ENGINEER
 LICENSED PROFESSIONAL ENGINEER
 STATE OF NJ LICENSE NO. 667391
 04-07-2017

BOROUGH OF ROSELLE
 INTERSECTION IMPROVEMENTS AT CHESTNUT STREET (CR 625) AND FIFTH AVENUE
 BOROUGH OF ROSELLE, UNION COUNTY, NEW JERSEY
 TRAFFIC CONTROL DETAILS

YOUR GOALS. OUR MISSION.
 11 TINDALL ROAD
 MIDDLETOWN, NJ 07748
 TEL 732-671-6400
 FAX 732-671-7365
 www.tandmassociates.com
 NEW JERSEY BOARD OF PROFESSIONAL ENGINEERS
 AND LAND SURVEYORS
 CERTIFICATE OF AUTHORIZATION 246A07907900
 OFFICES LOCATED IN:
 DELAWARE, INDIANA, KENTUCKY,
 MASSACHUSETTS, MICHIGAN, NEW JERSEY,
 OHIO AND PENNSYLVANIA

DESIGNED BY	IK	DRAWING	
CHECKED BY	BPK	MPT-1	
DRAWN BY	IK	SHEET	4
DATE	APRIL, 2017		
SCALE	NONE		
PROJ. NO.	UNCO0680	OF	31

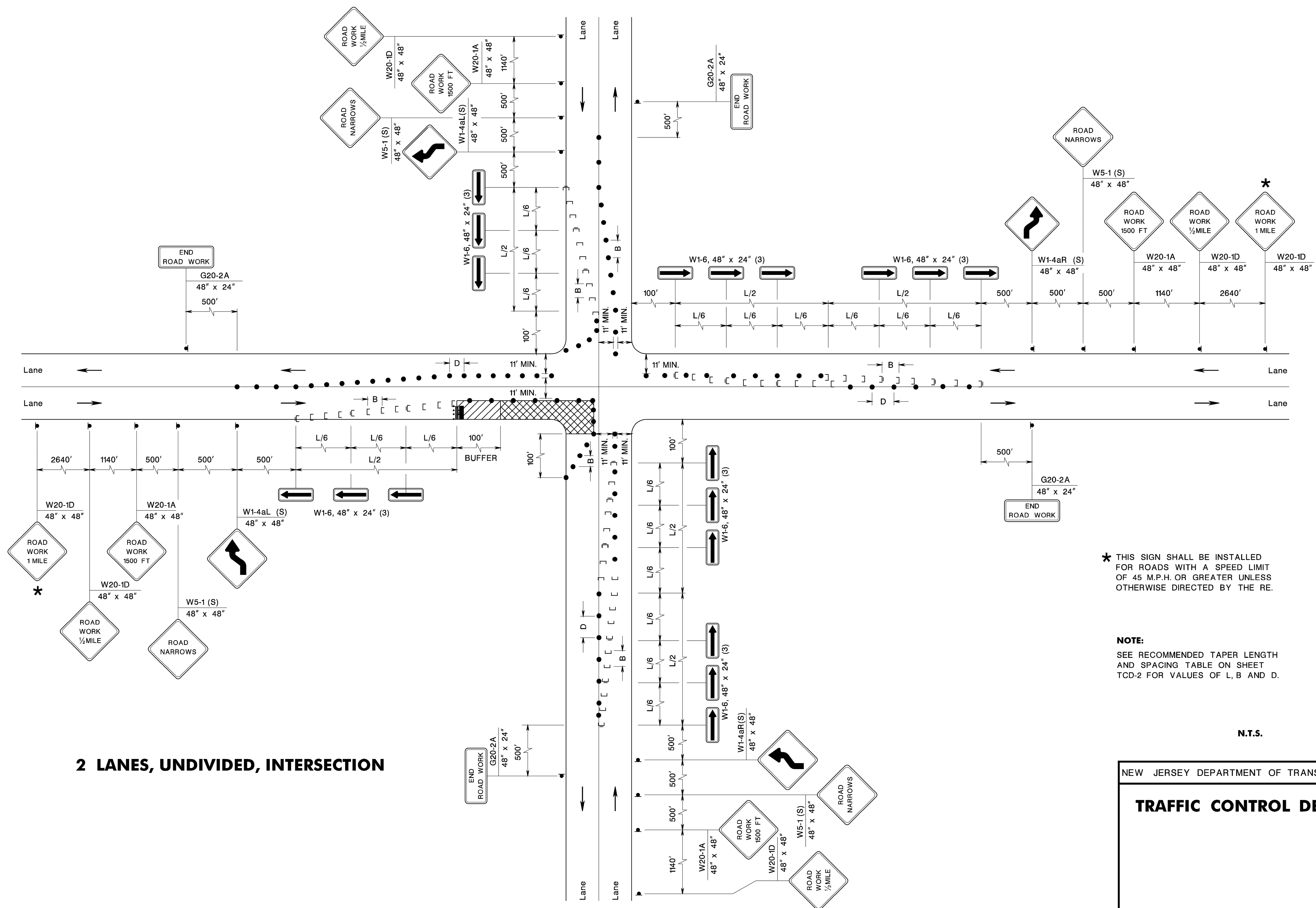

2 LANES, UNDIVIDED, INTERSECTION

* THIS SIGN SHALL BE INSTALLED FOR ROADS WITH A SPEED LIMIT OF 45 M.P.H. OR GREATER UNLESS OTHERWISE DIRECTED BY THE RE.

NOTE:
SEE RECOMMENDED TAPER LENGTH AND SPACING TABLE ON SHEET TCD-2 FOR VALUES OF L, B AND D.

N.T.S.

NEW JERSEY DEPARTMENT OF TRANSPORTATION

TRAFFIC CONTROL DETAILS

TCD-5

PROJECT INFORMATION: DRAWN BY: H. KLEIN, P.E. (CSP #49)
 FILE NAME: H:\PROJECTS\2017\CR 625\CONSTRUCTION\CP-1.dwg
 LAST SAVED DATE AND TIME: 10 Apr 2017, 10:56AM
 LAST SAVE BY: H. Klein

COPYRIGHT 2017, T&M ASSOCIATES, ALL RIGHTS RESERVED. THE COPYING OR REUSE OF THIS DRAWING OR ANY PART THEREOF WITHOUT THE WRITTEN PERMISSION OF T&M ASSOCIATES IS PROHIBITED.

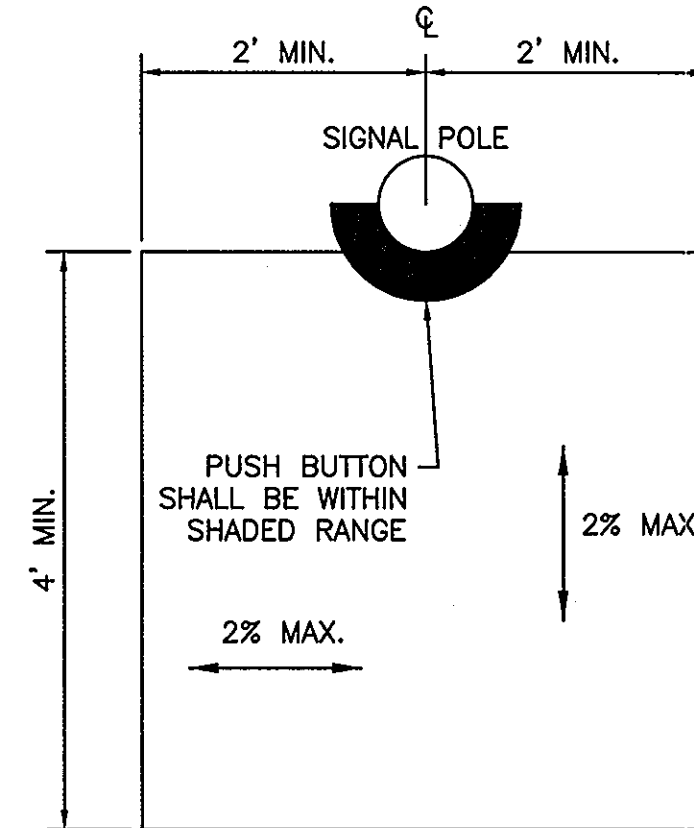
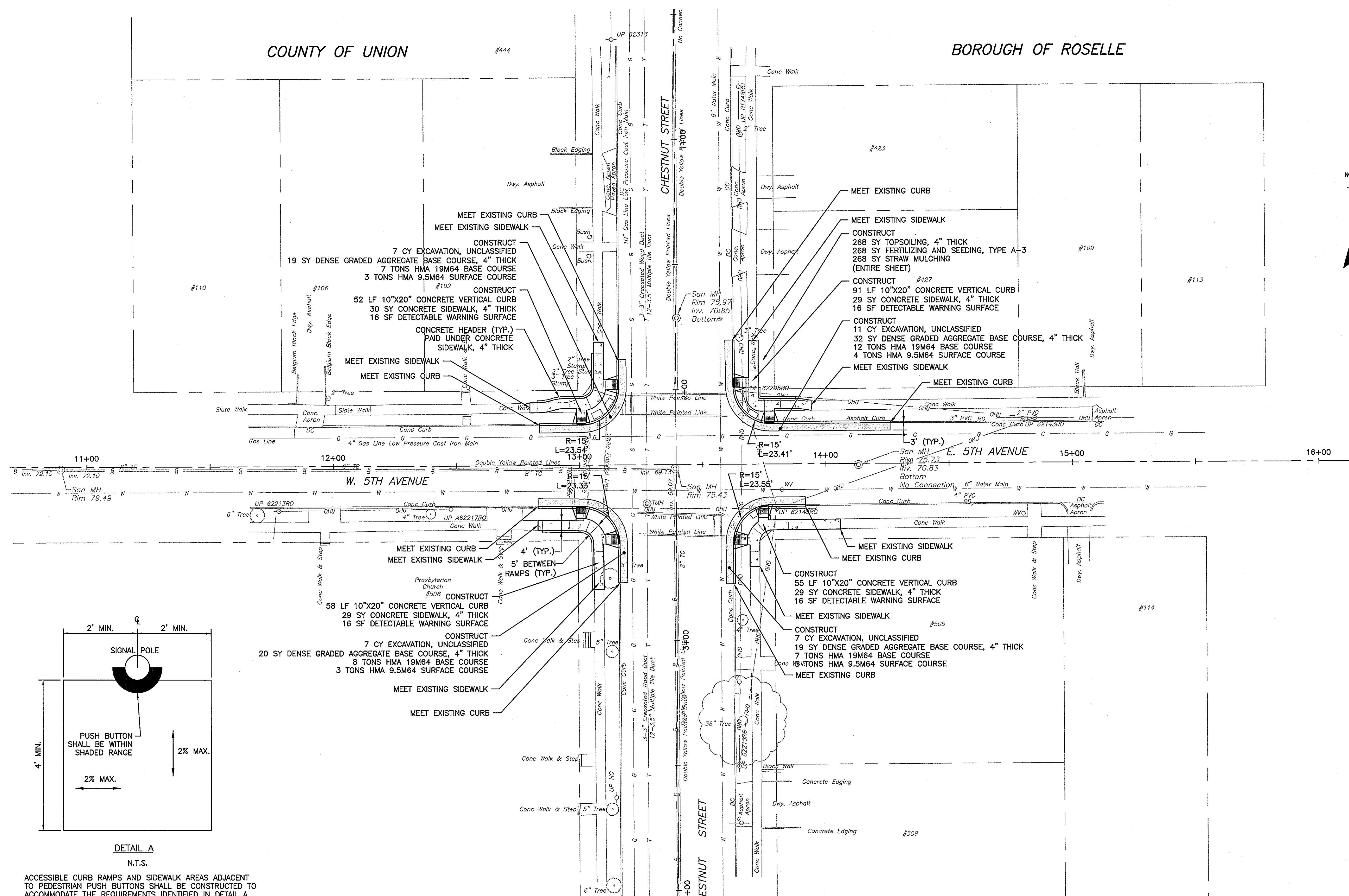

ACCESSIBLE CURB RAMP AND SIDEWALK AREAS ADJACENT TO PEDESTRIAN PUSH BUTTONS SHALL BE CONSTRUCTED TO ACCOMMODATE THE REQUIREMENTS IDENTIFIED IN DETAIL A.

TO BE CONSTRUCTED			
ITEM NO.	DESCRIPTION	UNIT	EST. QTY.
9	EXCAVATION, UNCLASSIFIED	CY	32
10	DENSE GRADED AGGREGATE BASE COURSE, 4" THICK	SY	90
11	HMA 9.5M64 SURFACE COURSE	TON	13
12	HMA 19M64 BASE COURSE	TON	34
13	CONCRETE SIDEWALK, 4" THICK	SY	117
14	DETECTABLE WARNING SURFACE	SY	8
15	10" X 20" CONCRETE VERTICAL CURB	LF	256
40	TOPSOILING, 4" THICK	SY	268
41	FERTILIZING & SEEDING, TYPE A-3	SY	268
42	STRAW MULCHING	SY	268

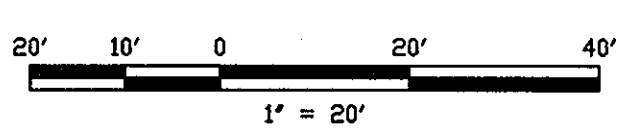

NO.	DATE	REVISIONS	BY	CHKD

BRUCE P. KLEIN, P.E.
 CONSULTING ENGINEER
 04-07-2017
 Bruce Klein
 LICENSED PROFESSIONAL ENGINEER
 STATE OF NJ LICENSE NO. 6E47391

BOROUGH OF ROSELLE
 INTERSECTION IMPROVEMENTS AT CHESTNUT STREET (CR 625) AND FIFTH AVENUE
 BOROUGH OF ROSELLE, UNION COUNTY, NEW JERSEY
 CONSTRUCTION PLAN

T&M
 AND
 YOUR GOALS. OUR MISSION.

11 TINDALL ROAD
 MIDDLETOWN, NJ 07748
 TEL: 732-671-4800
 FAX: 732-671-7365
 www.tandmassociates.com
 NEW JERSEY BOARD OF PROFESSIONAL ENGINEERS
 AND LAND SURVEYORS
 CERTIFICATE OF AUTHORIZATION 24621987500

OFFICES LOCATED IN:
 DELAWARE, INDIANA, KENTUCKY,
 MASSACHUSETTS, MICHIGAN, NEW JERSEY,
 OHIO AND PENNSYLVANIA

DESIGNED BY	IK	DRAWING	CP-1
CHECKED BY	BPK	DRAWN BY	IK
DATE	APRIL, 2017	SCALE	1"=20'
PROJ. NO.	UNCO06880	SHEET	7 OF 31

OVERHEAD STREET NAME SIGNS

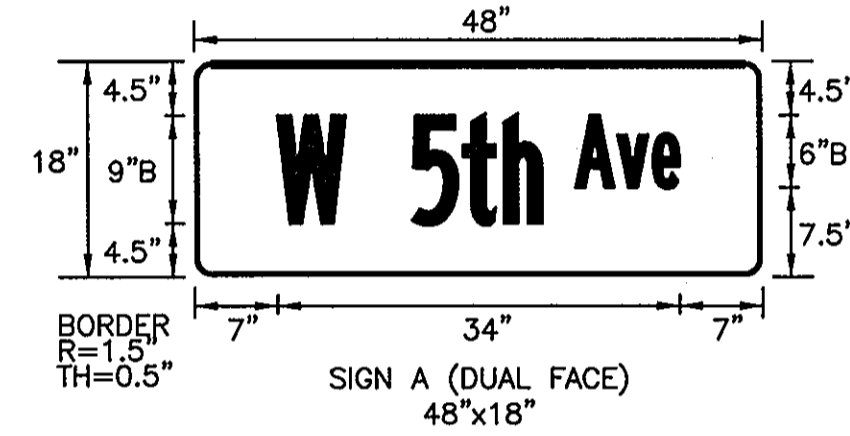
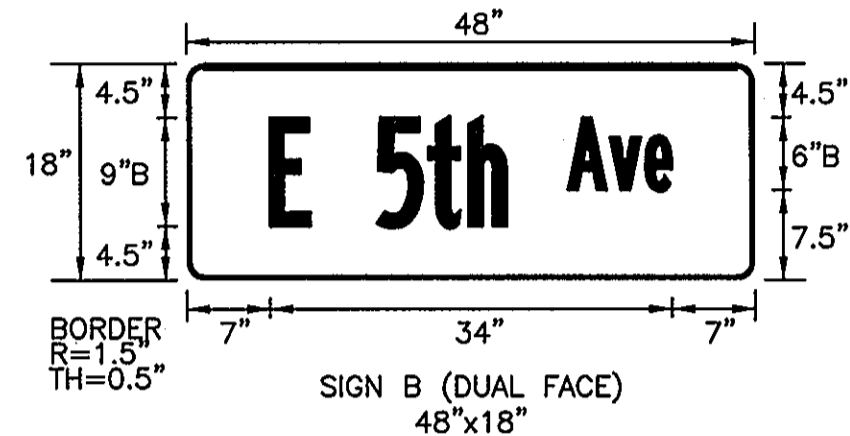
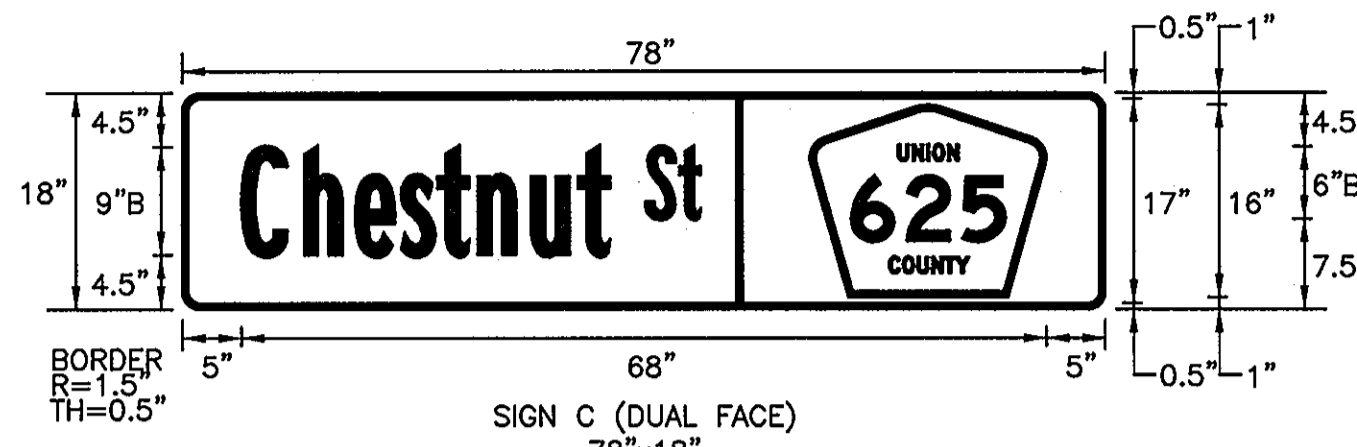

1. ALL STREET NAME SIGNS SHALL HAVE WHITE LEGEND ON GREEN BACKGROUND. EXCEPT COUNTY ROUTE MARKER, WHICH SHALL HAVE YELLOW LEGEND ON BLUE BACKGROUND.
2. STREET NAME LETTERING TO BE 9" B, AND "ST" 6" B.

NOTES:

1. ALL TRAFFIC CONTROL DEVICES SHALL CONFORM WITH THE "MANUAL ON UNIFORM TRAFFIC CONTROL DEVICES", CURRENT EDITION.
2. TREE BRANCHES SHALL BE TRIMMED AS NECESSARY AT THE DIRECTION OF THE ENGINEER.
3. ALL TRAFFIC SIGNAL INDICATIONS AND PEDESTRIAN SIGNALS SHALL BE LED.
4. ALL ALUMINUM ALLOY SIGNAL STANDARDS SHALL BE A MINIMUM OF 32 INCHES FROM FACE OF CURB TO CENTER OF STANDARD.
5. TRAFFIC SIGNAL HEADS 1 - 8 TO BE MOUNTED AT A MIN. HEIGHT OF 15'-6".
6. PEDESTRIAN SIGNAL HEADS 9-16 TO BE MOUNTED AT 8 FT.
7. WIRE CODING TO CONFORM WITH CURRENT STANDARDS IN USE BY THE COUNTY OF UNION.
8. #8 AWG, INSULATED (COLORED GREEN) GROUND WIRE SHALL BE INSTALLED CONTINUOUS THROUGHOUT THE TRAFFIC SIGNAL SYSTEM AND SECURED TO ALL GROUND RODS, CABINETS, AND TRAFFIC SIGNAL BASES.
9. CONTRACTOR SHALL COORDINATE AND OBTAIN ELECTRICAL SERVICE FOR THE INTERSECTION.
10. CONTRACTOR SHALL VERIFY LOCATION OF ALL UNDERGROUND UTILITIES PRIOR TO INSTALLATION OF SIGNAL DEVICES AND SIGNS. TEST PITS SHALL BE REQUIRED AT LOCATIONS OF SIGNAL POLE FOUNDATIONS AS DIRECTED BY THE ENGINEER PRIOR TO ORDERING SIGNAL EQUIPMENT AND CONSTRUCTION OF CURB RAMPS, SIDEWALK, AND FOUNDATIONS.
11. MOUNTING LOCATIONS FOR THE IMAGE DETECTORS SHALL BE DETERMINED BY THE MANUFACTURER'S REPRESENTATIVE TO ASSURE PROPER OPERATION.
12. THE CONTROLLER SHALL BE EQUIPPED WITH A GENERATOR CONNECTION.
13. ALL POLES, BASES, CABINETS AND HARDWARE SHALL BE POWDER-COATED GLOSS BLACK.

PHASING DIAGRAM

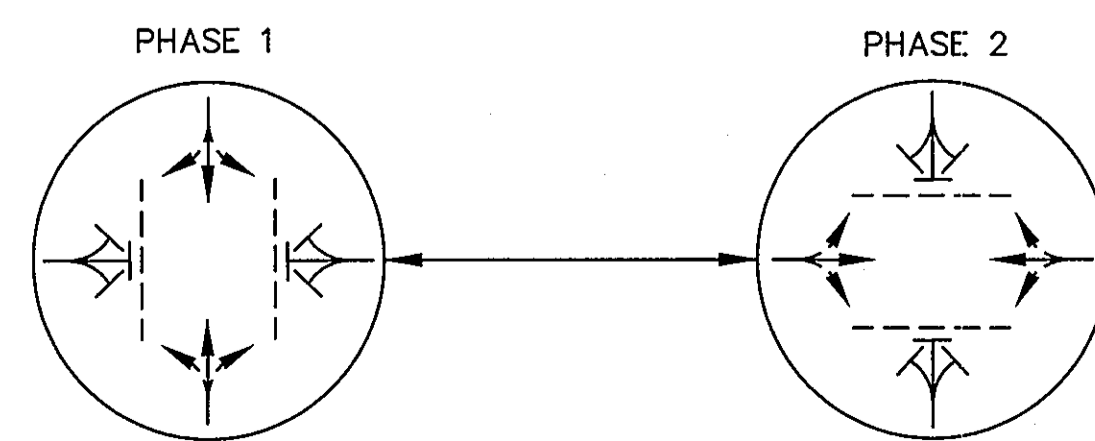

SIGNAL LEGEND

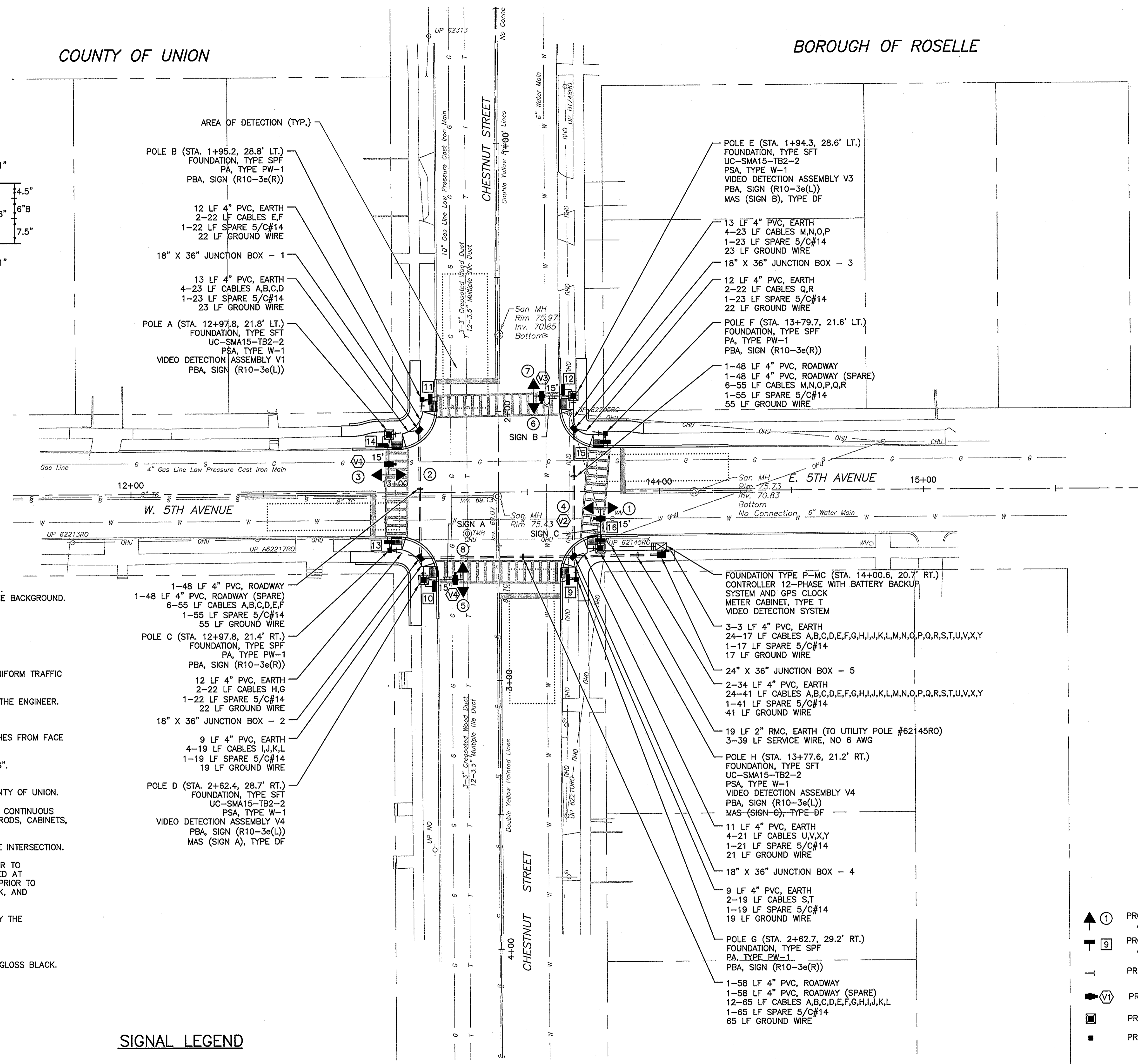
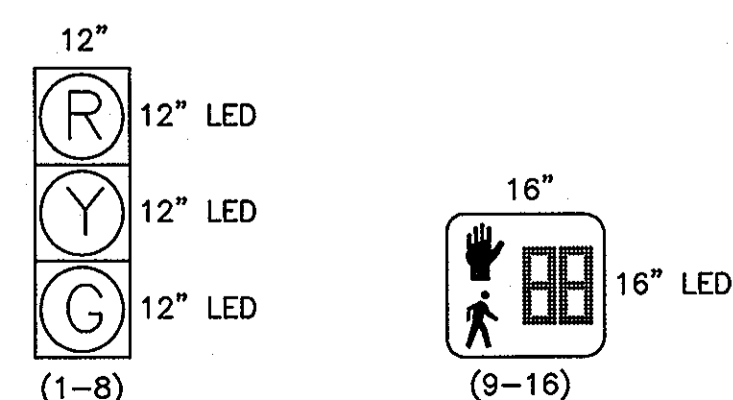

LEGEND

- 1 PROPOSED VEHICULAR SIGNAL HEAD AND IDENTIFYING NUMBER
- 2 PROPOSED PEDESTRIAN SIGNAL HEAD AND IDENTIFYING NUMBER
- 3 PROPOSED PEDESTRIAN PUSH BUTTON AND PUSHBUTTON SIGN
- 4 PROPOSED IMAGE DETECTOR
- 5 PROPOSED TRAFFIC SIGNAL POLE
- 6 PROPOSED PEDESTAL POLE

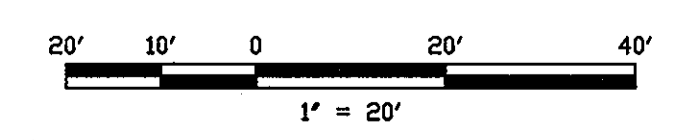

PROJECT INFORMATION: DESIGNER: [Name], FILE NAME: UNCO060880, DATE: 04-07-2017, 9:52AM, LAST SAVED DATE AND TIME: 12 Apr 2017, 9:52AM, LAST SAVE BY: [Name]

NO.	DATE	REVISIONS	BY	CHKD

BRUCE P. KLEIN, P.E.
CONSULTING ENGINEER

04-07-2017

Bruce Klein
LICENSED PROFESSIONAL ENGINEER
STATE OF NJ LICENSE NO. 6E47351

BOROUGH OF ROSELLE

INTERSECTION IMPROVEMENTS AT CHESTNUT STREET (CR 625) AND FIFTH AVENUE

BOROUGH OF ROSELLE, UNION COUNTY, NEW JERSEY

ELECTRICAL PLAN

AND

YOUR GOALS. OUR MISSION.

11 TINDALL ROAD
MIDDLETOWN, NJ 07748
TEL 732-671-6400
FAX 732-671-7365

www.landmassassociates.com

NEW JERSEY BOARD OF PROFESSIONAL ENGINEERS AND LAND SURVEYORS
CERTIFICATE OF AUTHORIZATION 246A27907500

OFFICES LOCATED IN:
DELAWARE, INDIANA, KENTUCKY,
MASSACHUSETTS, MICHIGAN, NEW JERSEY,
OHIO AND PENNSYLVANIA

DESIGNED BY	JL	DRAWING	ELP-1
CHECKED BY	BPK	SHEET	10
DRAWN BY	IK	OF	31
DATE	APRIL, 2017	SCALE	1"=20'
PROJ. NO.	UNCO060880		

pen table= \\NJDOTPRWS\Projects\NJDOT\Eng\plan\TBL\Roadway\Details_13x17.tbl
 scale=63.073306:1.000000
 date=28-SEP-2016 11:07
 ID=TP2VILL
 BDC18-D-ORIGINAL SHEET

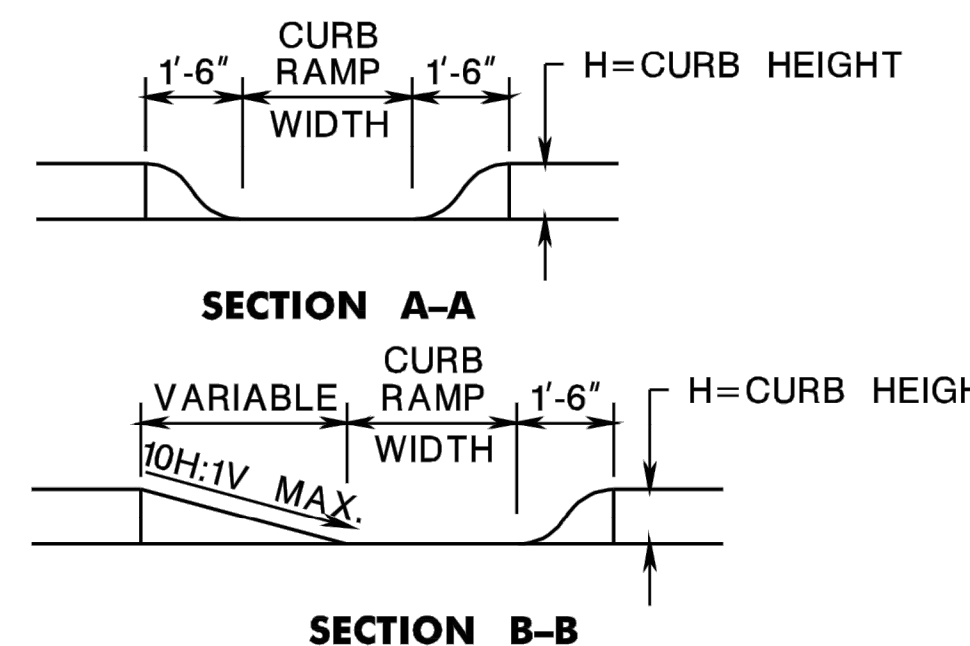
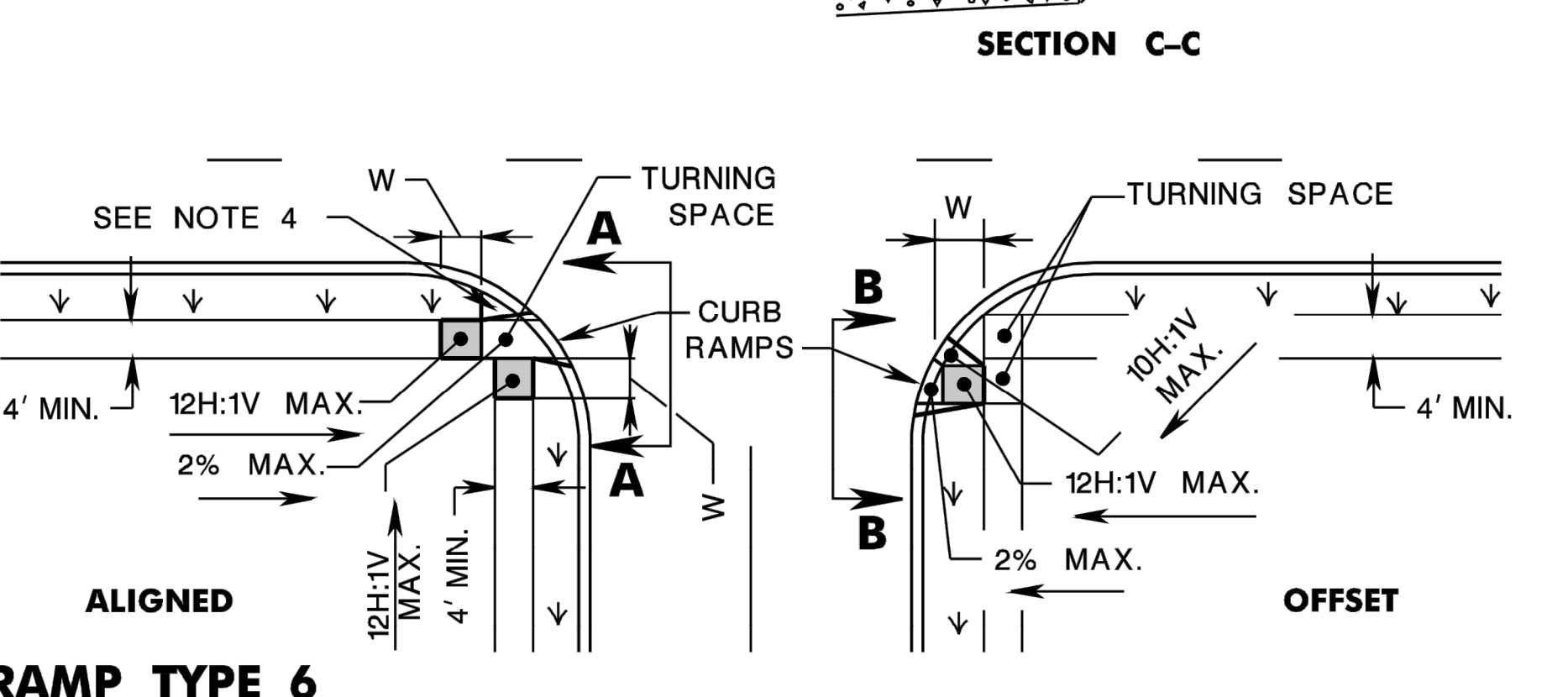
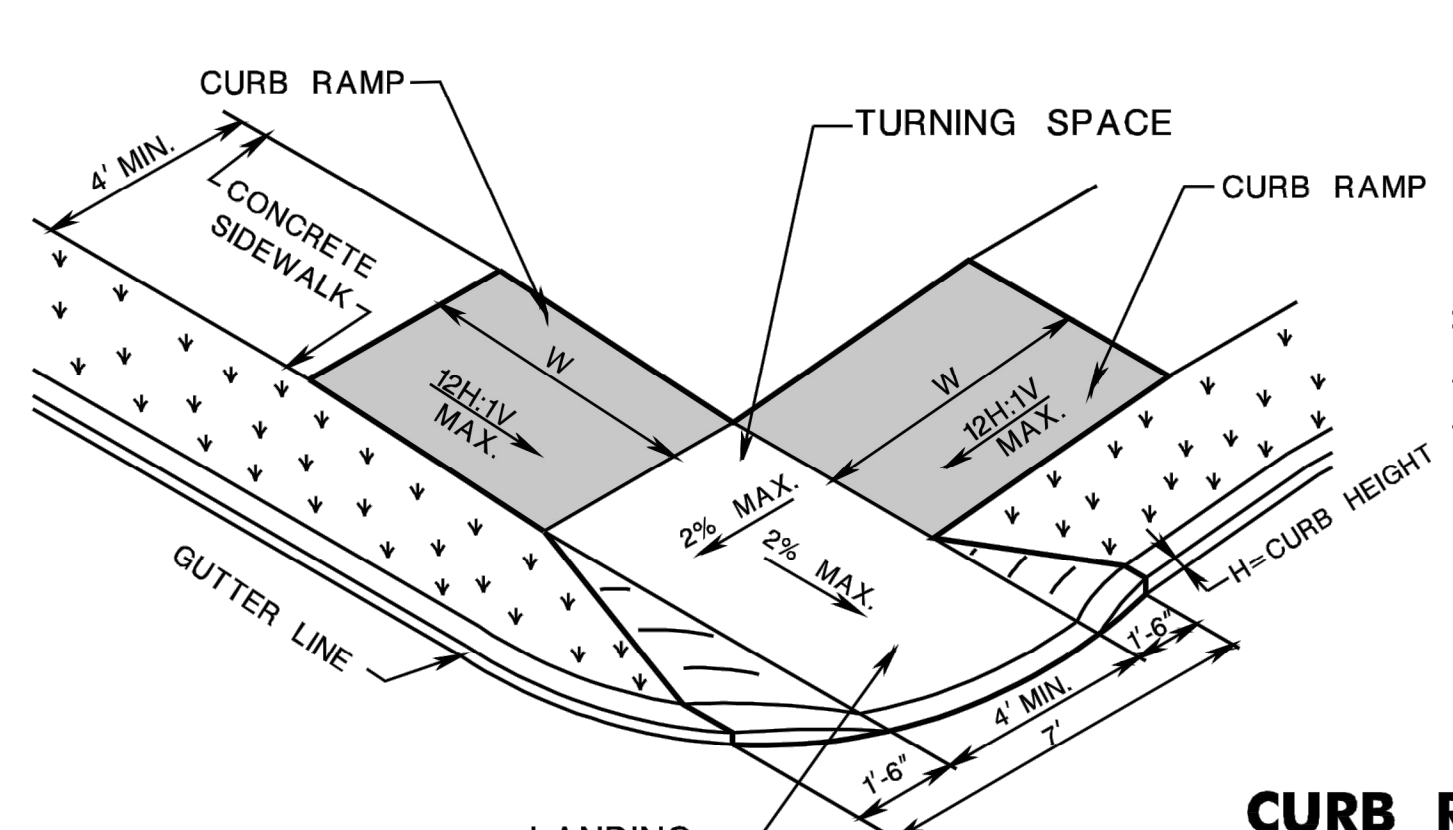
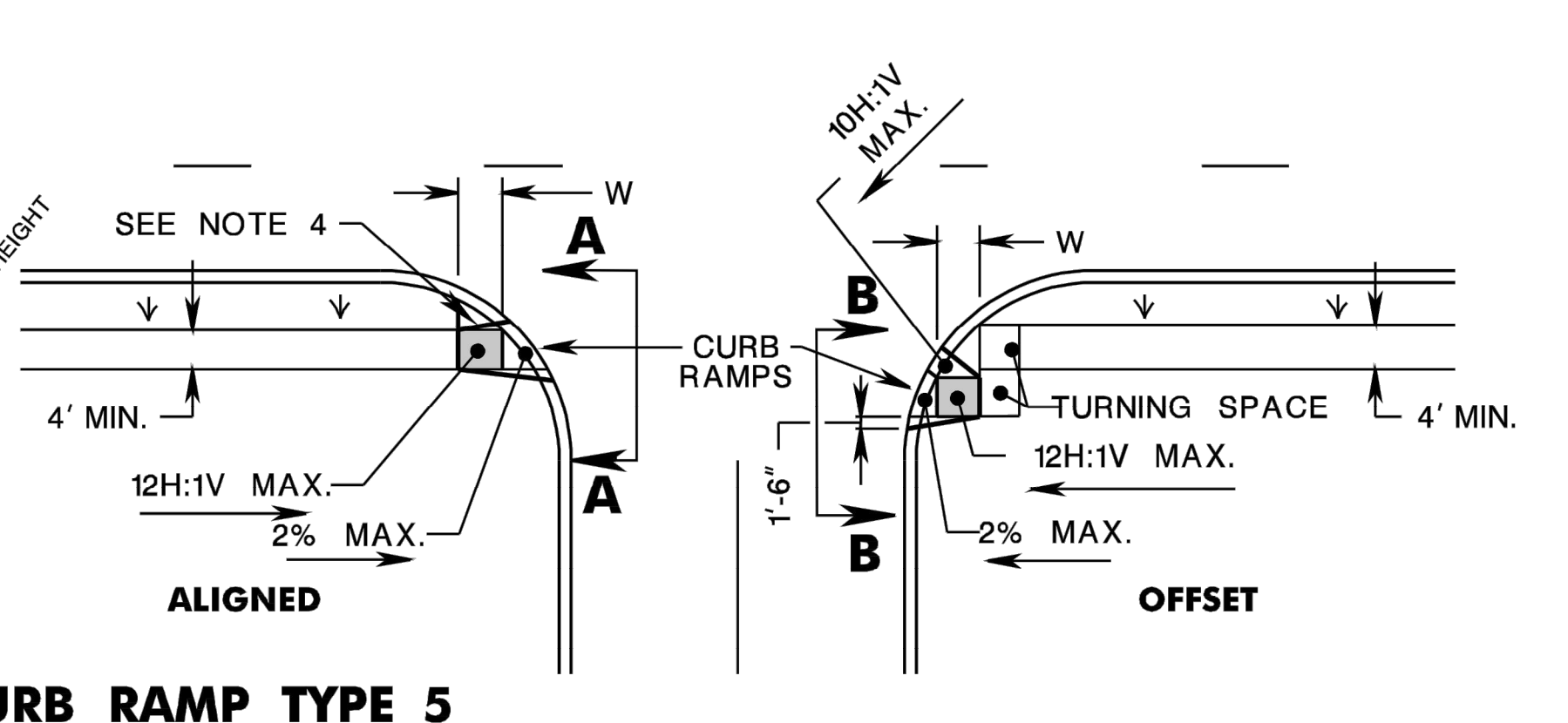
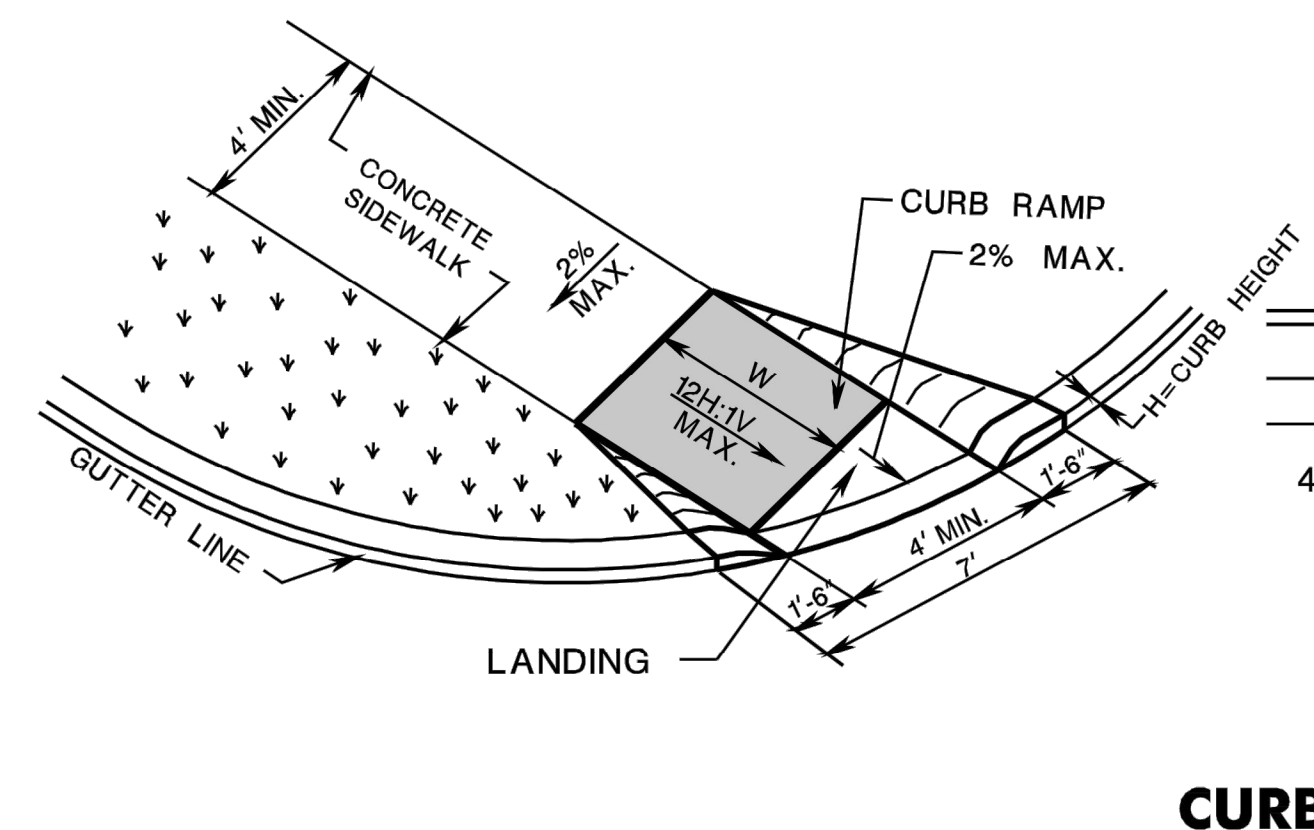
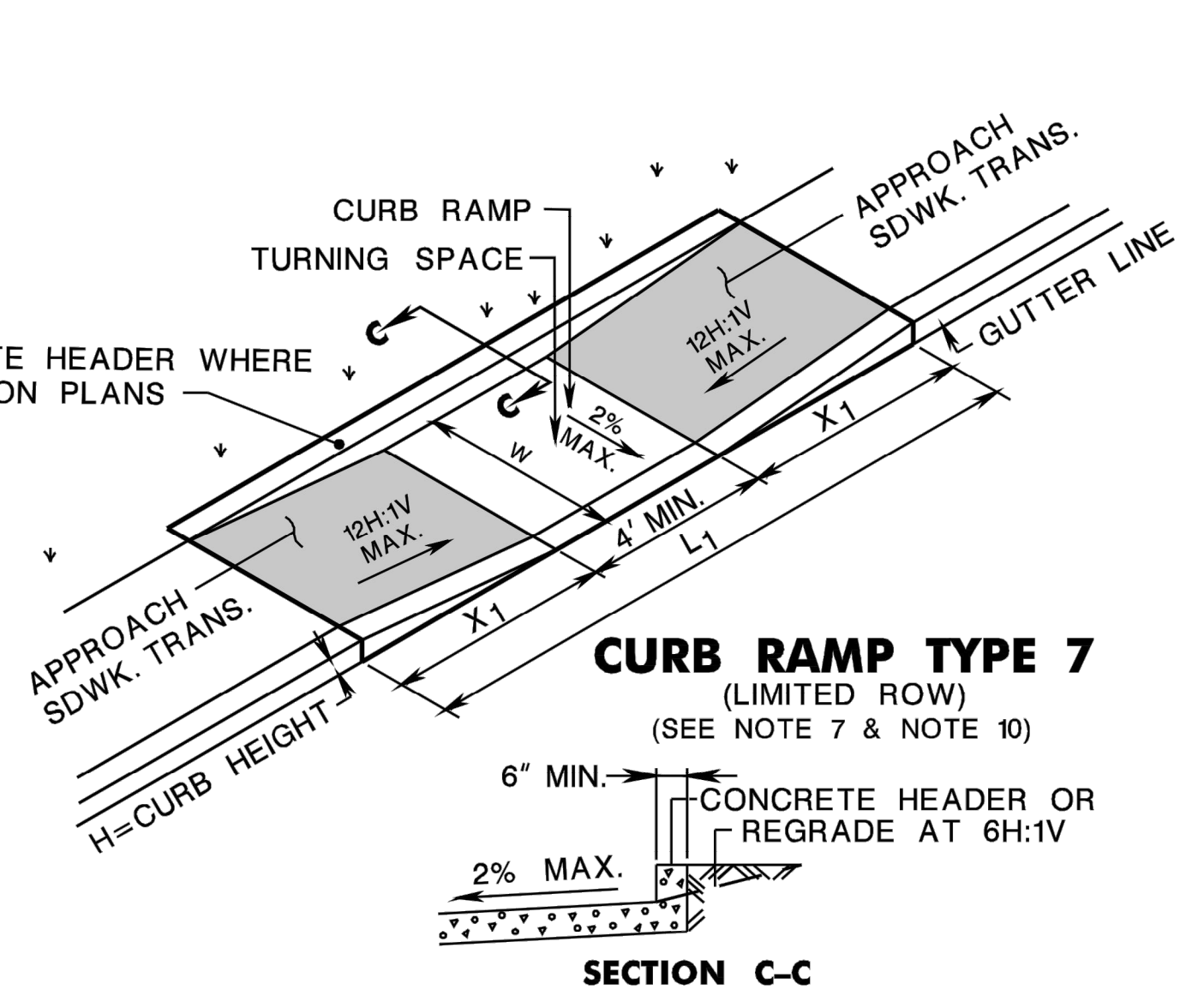
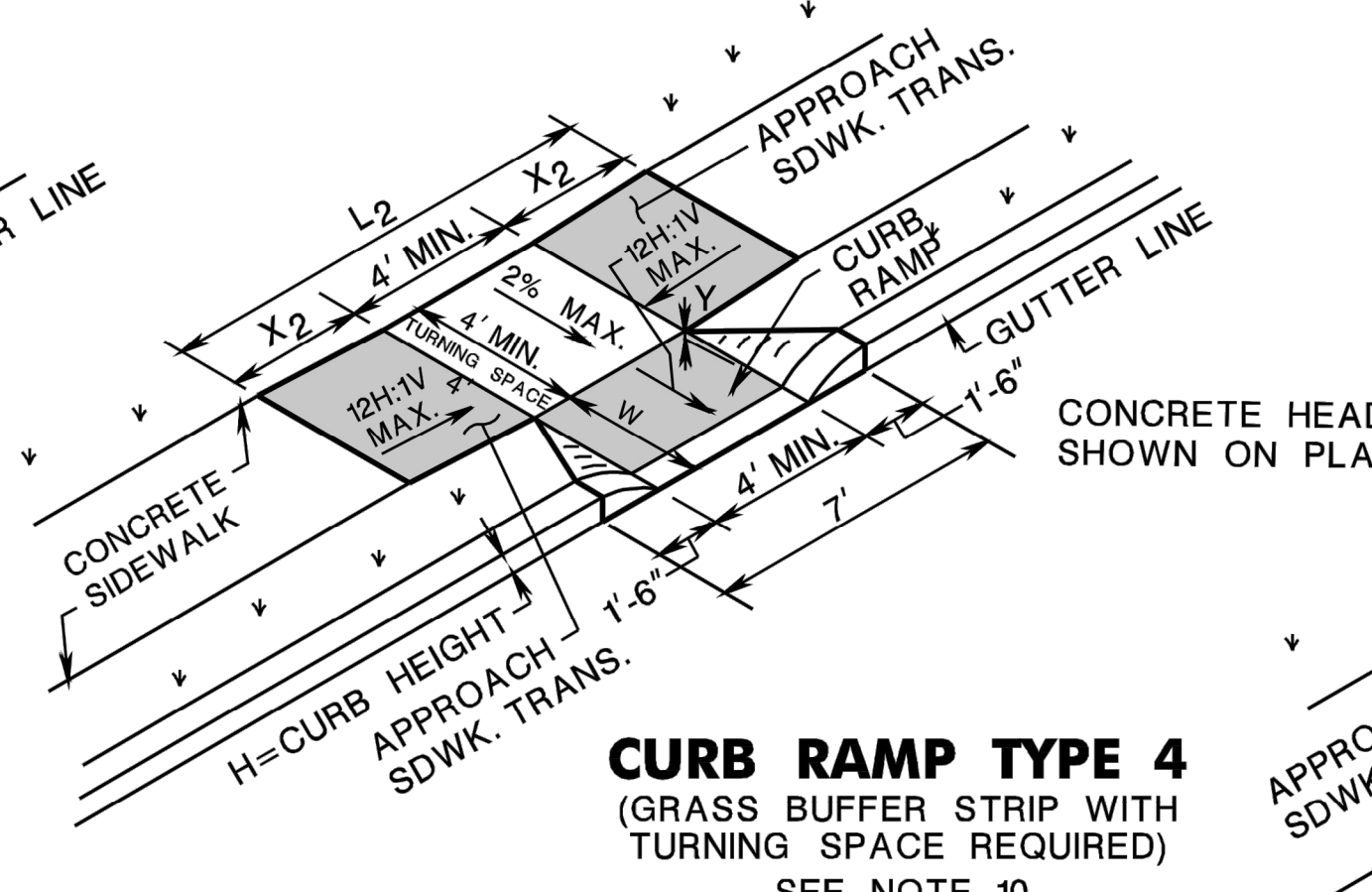
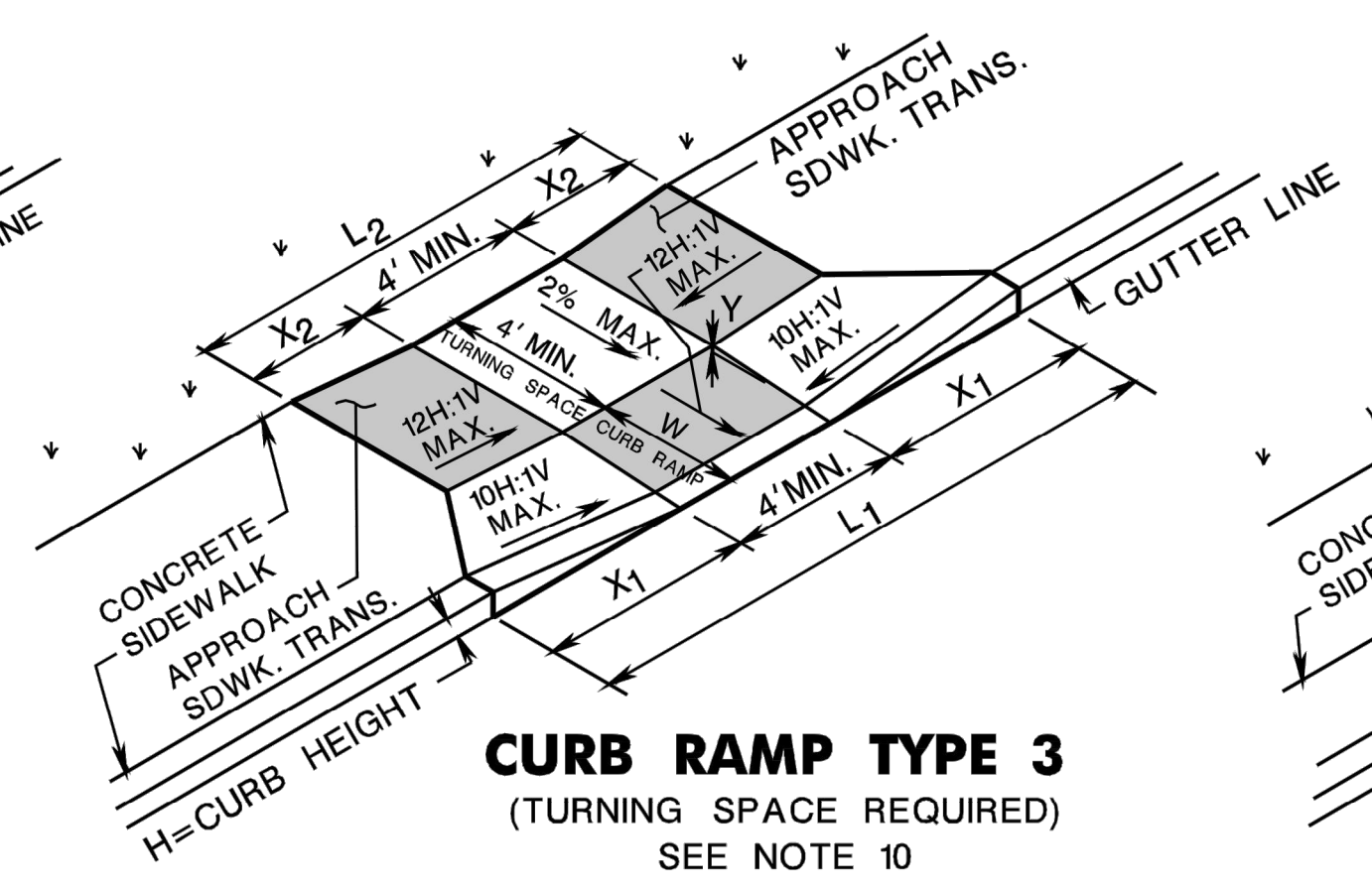
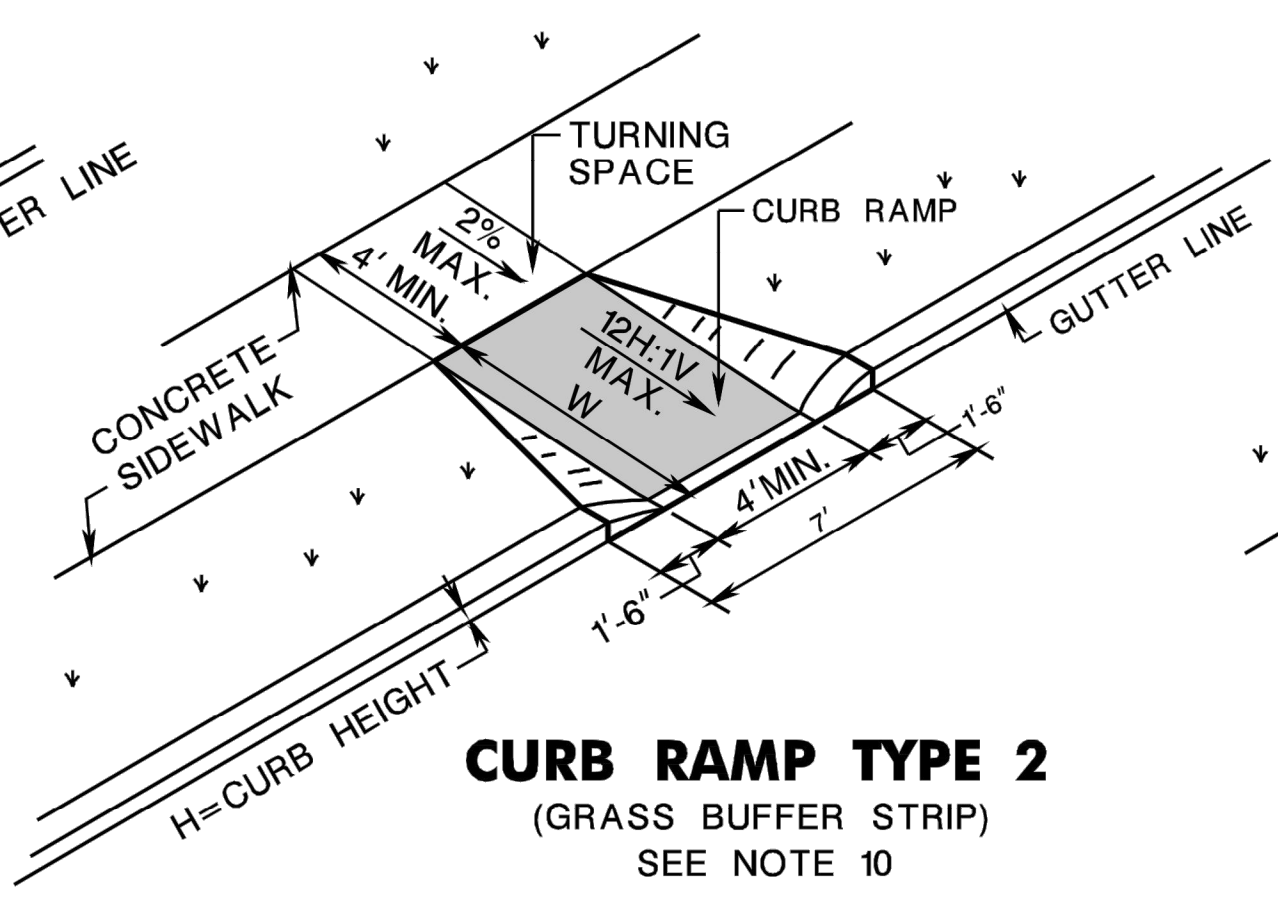
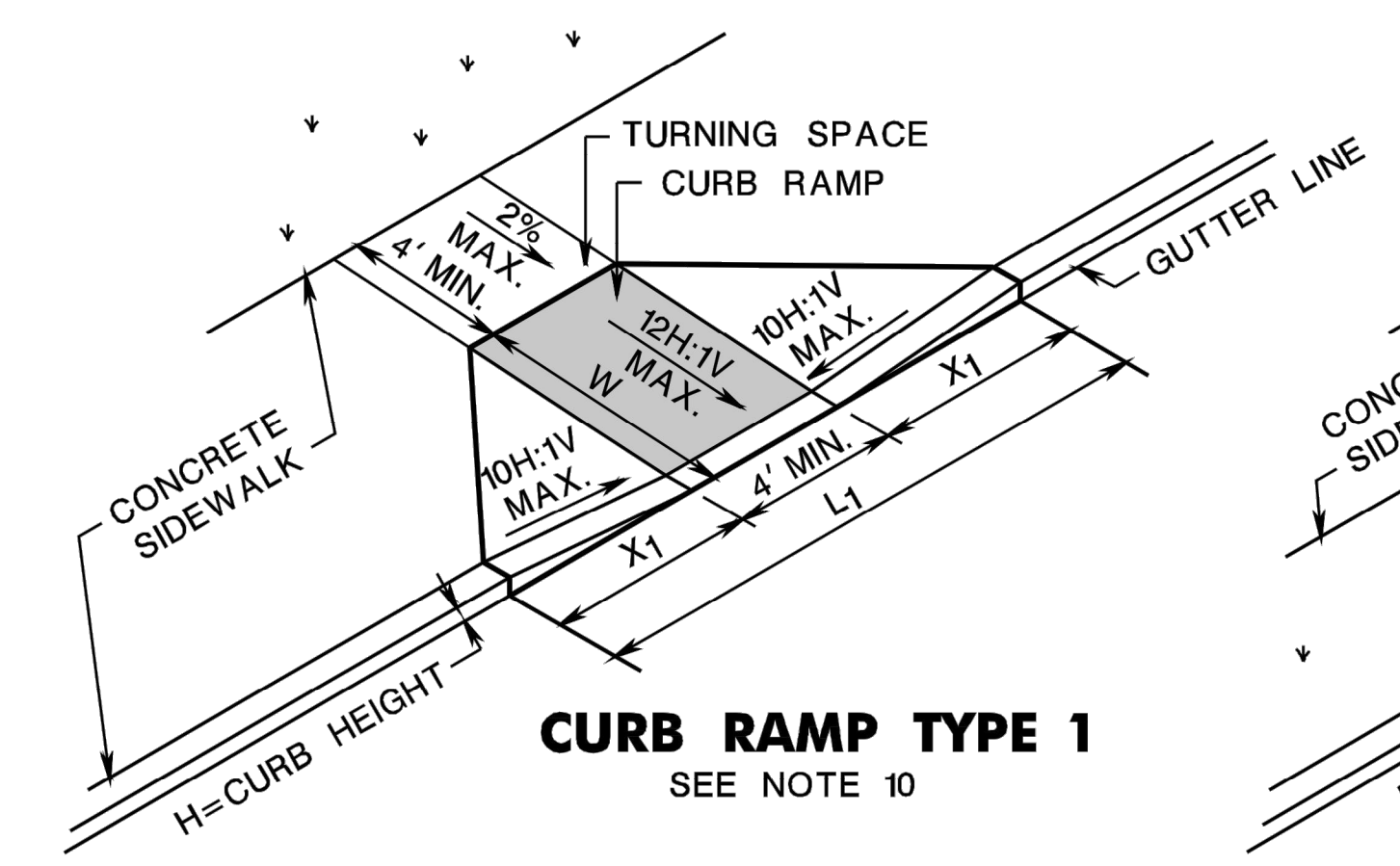

NOTE:
 CURB RAMP OPENING TO BE FLUSH WITH ROADWAY PAVEMENT (CURB RAMP TYPES 5 & 6).

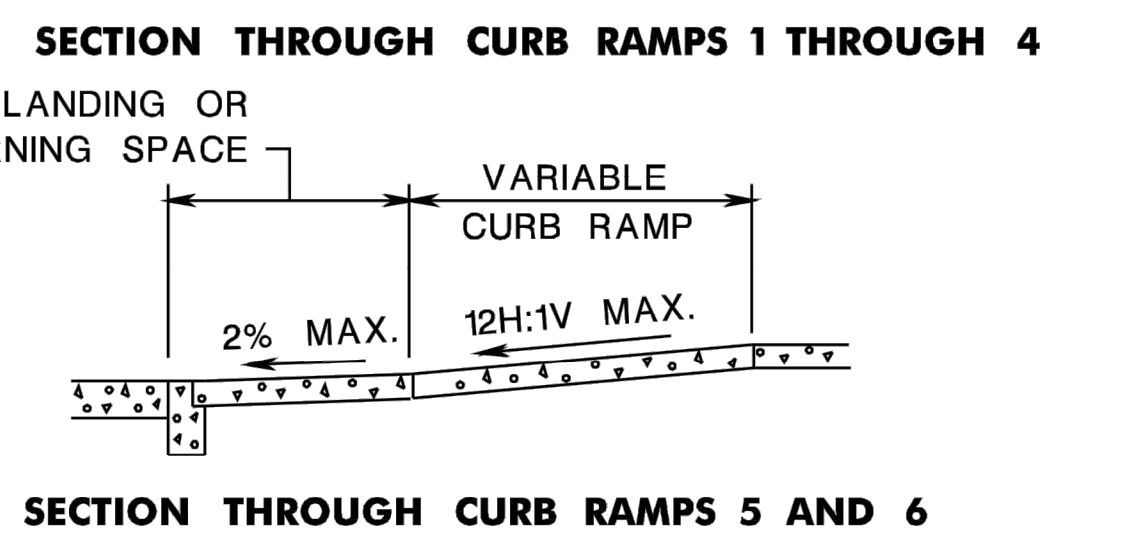
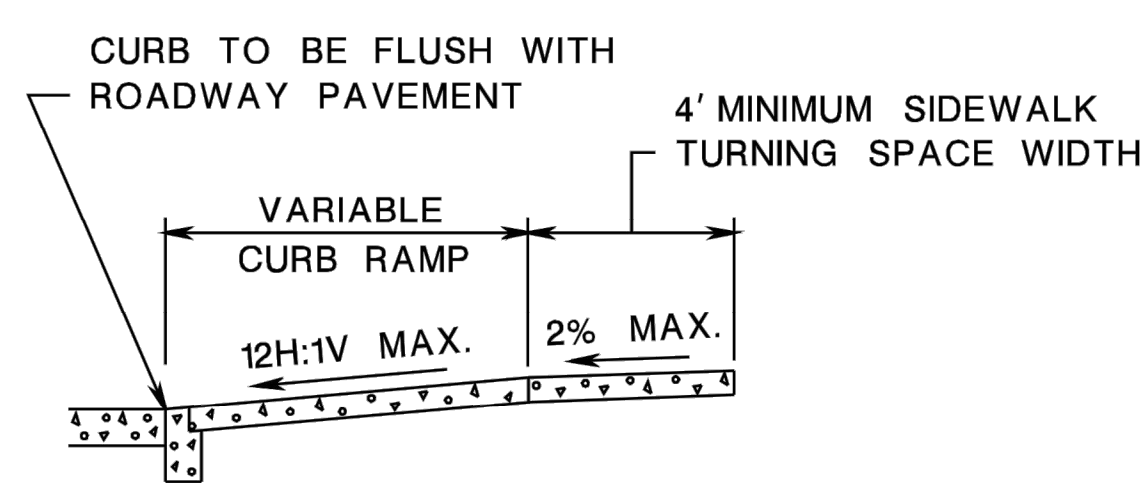

- NOTES:**
- KEEP TURNING SPACE, APPROACH SIDEWALK TRANSITIONS, AND CURB RAMP CLEAR OF OBSTRUCTIONS THAT PROTRUDE ABOVE THE SURFACE.
 - FOR DIMENSIONS SEE CD-606-3 AND CD-606-4
 - CURB (DROPPED CURB) GUTTERLINE TO BE FLUSH WITH ROADWAY PAVEMENT THE ENTIRE WIDTH OF THE RAMP (4 FEET MIN.) AT ALL CURB RAMPS.
 - FOR CURB RAMP TYPES 5 AND 6, IF A GRASS BUFFER DOES NOT EXIST, SLOPE CURB TO EQUAL SLOPE OF ADJACENT CURB RAMP.
 - SIDEWALK AND CURB RAMP WITHIN AREA ENCLOSED BY HEAVY LINES INDICATES THE PAY LIMIT FOR CONCRETE SIDEWALK OF THE APPROPRIATE ADJACENT THICKNESS.
 - CURB AND HEADER WITHIN AREA ENCLOSED BY HEAVY LINES INDICATES THE PAY LIMIT FOR VERTICAL CURB OR SLOPING CURB OF THE APPROPRIATE ADJACENT SIZE AND KIND.
 - WHERE THE DISTANCE FROM THE GUTTER LINE TO THE OUTSIDE EDGE OF SIDEWALK IS 6 FEET OR LESS, USE CURB RAMP TYPE 7, INSTEAD OF CURB RAMP TYPE 1 THROUGH 4.
 - CROSSWALKS AND STOP LINES MAY BE MARKED OR UNMARKED. SEE PLANS.
 - THE 12H:1V MAX SLOPE IS THE RUNNING SLOPE FOR CURB RAMPS, BUT ONLY THE 12H:1V SLOPE MEASURED AS X₂ IS THE RUNNING SLOPE FOR TYPE 3 AND TYPE 4 CURB RAMPS. ENSURE THE RUNNING SLOPE OF CURB RAMPS DOES NOT REQUIRE ITS LENGTH TO EXCEED 15 FEET. THE RUNNING SLOPE MAY EXCEED THE 12H:1V MAX SLOPE SO AS NOT TO EXCEED THE 15 FEET MAXIMUM LENGTH.
 - CURB RAMP TYPE 1 THROUGH 7 ARE NORMALLY PLACED ON THE RADIUS RETURN AT THE INTERSECTION AND ON A TANGENT SECTION AS DRAWN.

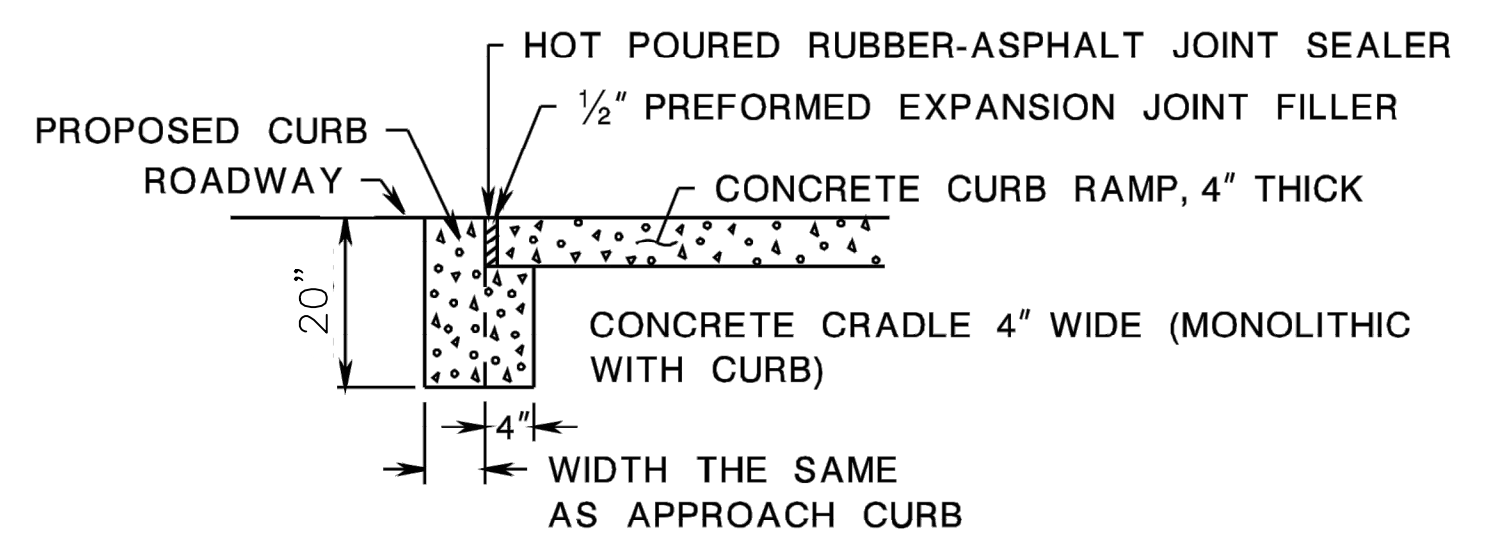

DROPPED CURB AND CRADLE

CONCRETE SIDEWALK
 (PUBLIC SIDEWALK CURB RAMP)
 N.T.S.

NEW JERSEY DEPARTMENT OF TRANSPORTATION

CONSTRUCTION DETAILS

CURB RAMPS

CD-606-1.1

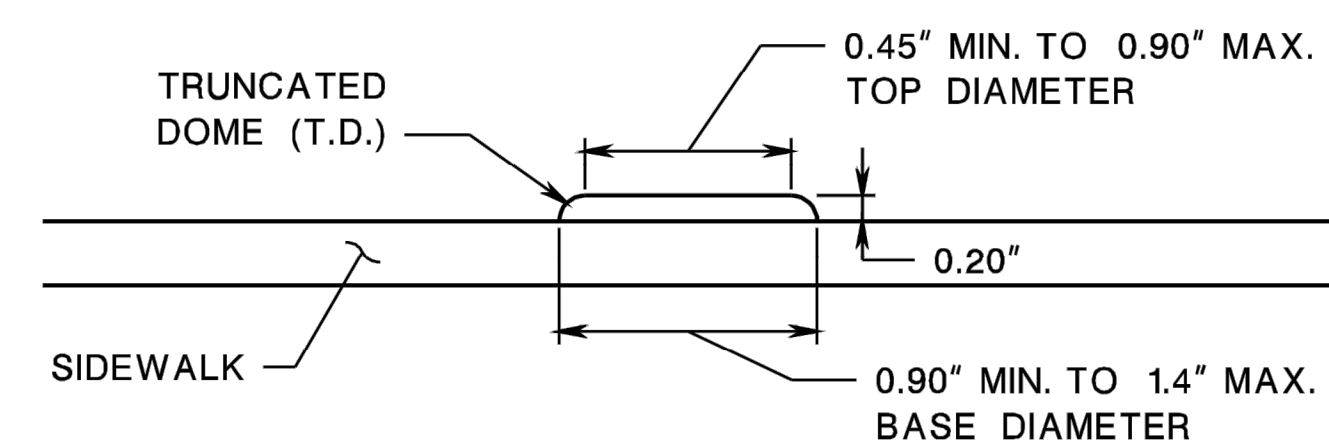
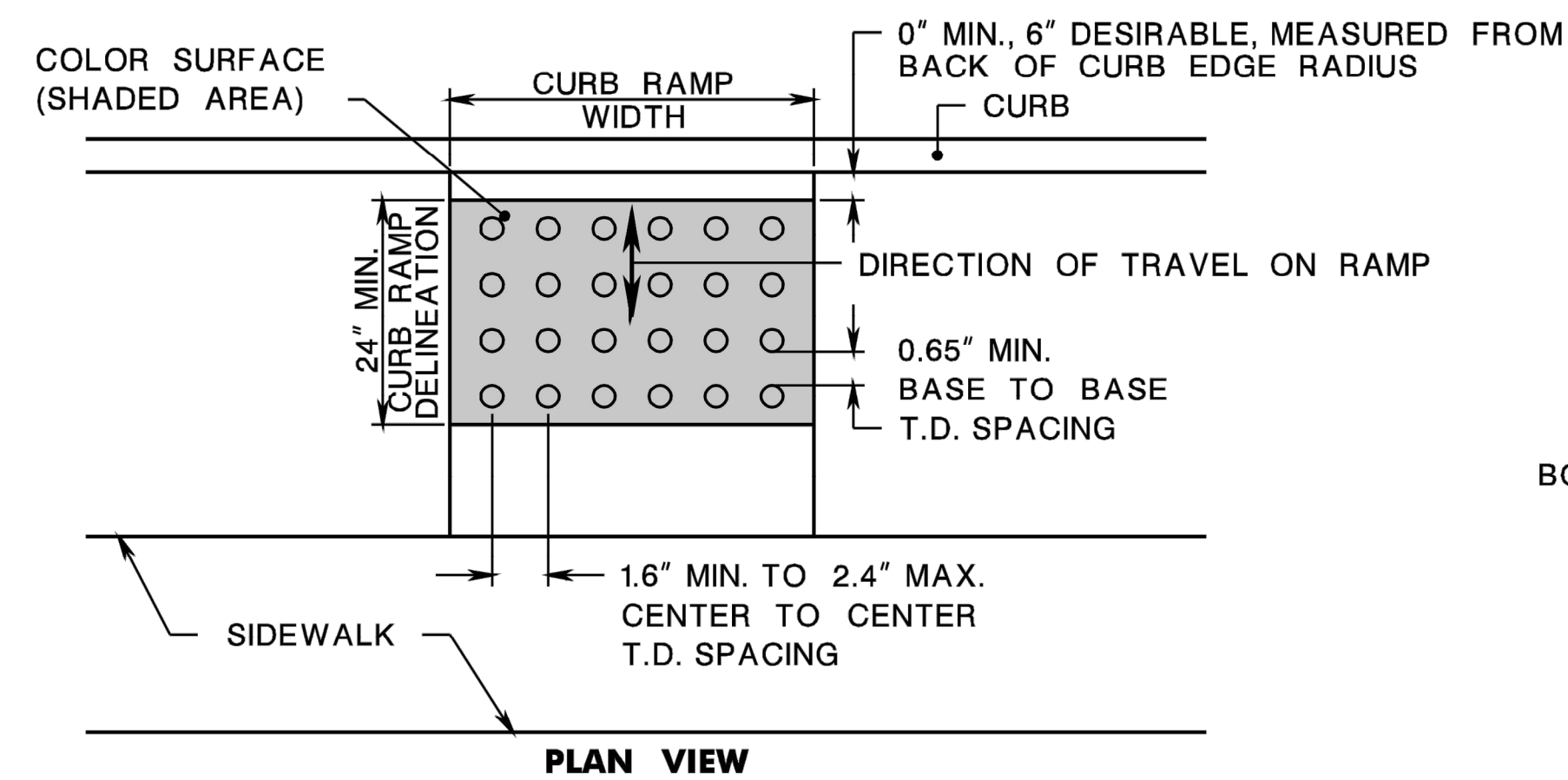

DETECTABLE WARNING SURFACE

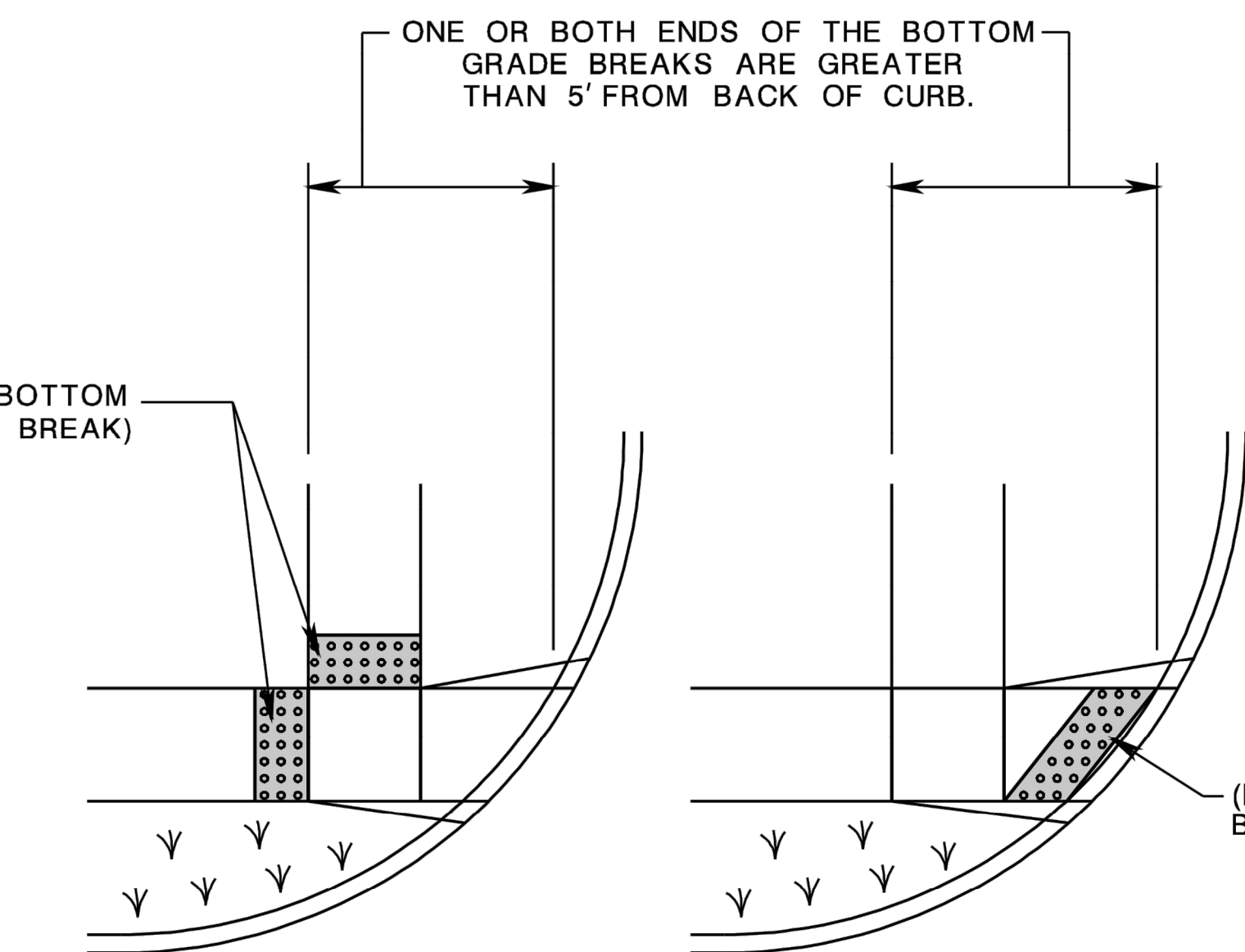
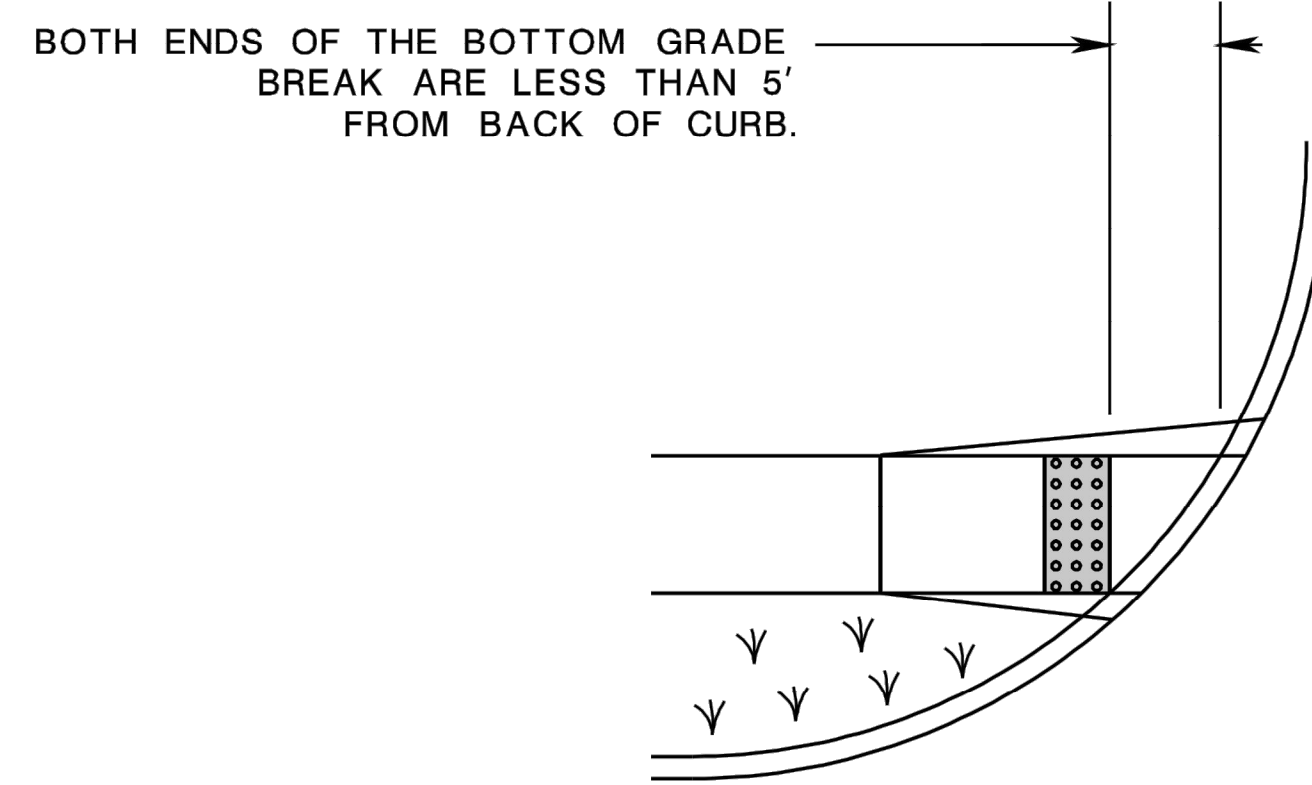

PLACEMENT OF DETECTABLE WARNING SURFACE FOR CURB RAMP TYPE 5 AND 6

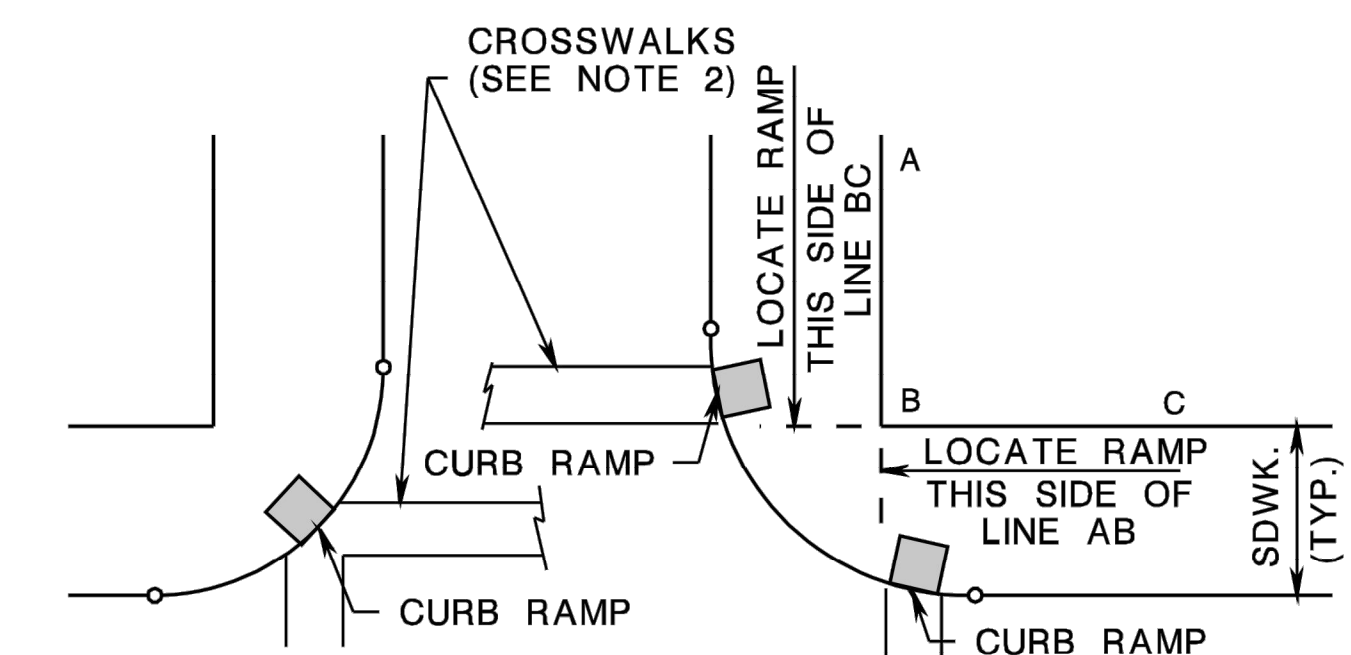

LOCATION OF CURB RAMP TYPES 1, 2, 3, 4, & 7 FOR CROSSING PARALLEL AND PERPENDICULAR TO HIGHWAY

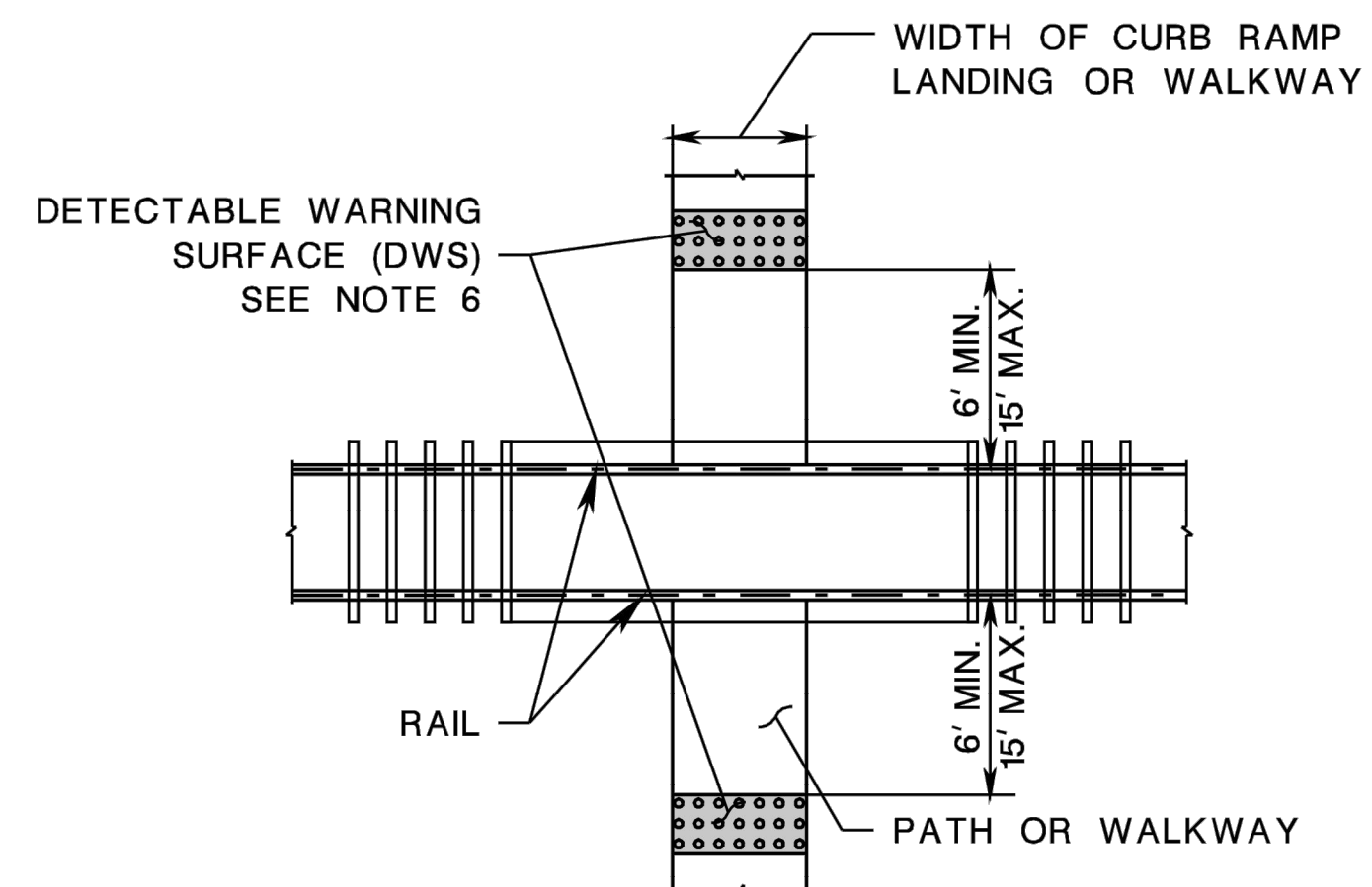

PEDESTRIAN RAILROAD CROSSING

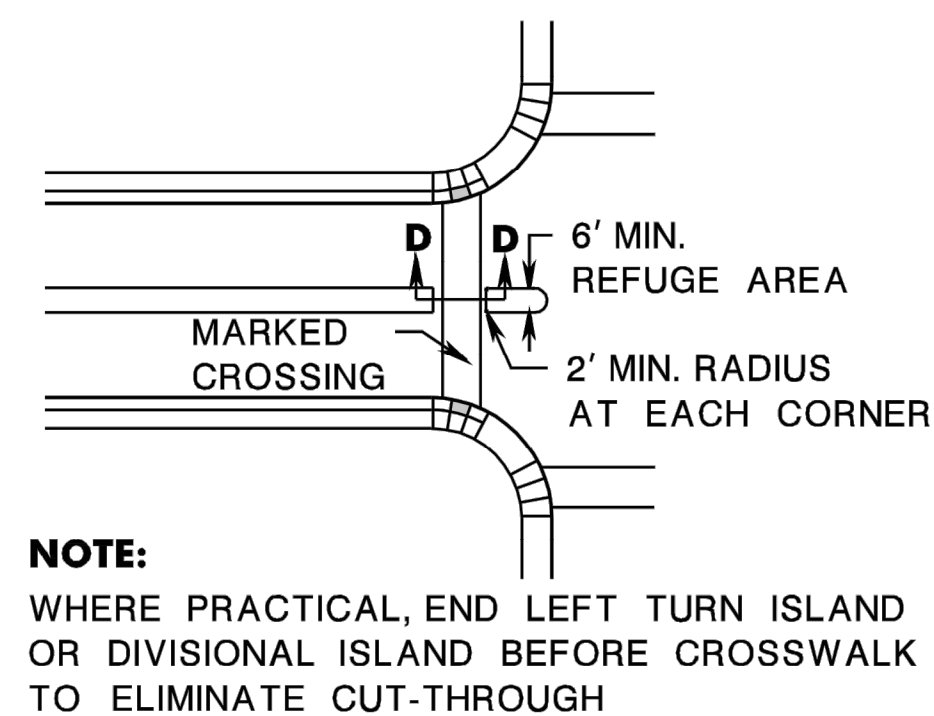

NOTE:
WHERE PRACTICAL, END LEFT TURN ISLAND OR DIVISIONAL ISLAND BEFORE CROSSWALK TO ELIMINATE CUT-THROUGH

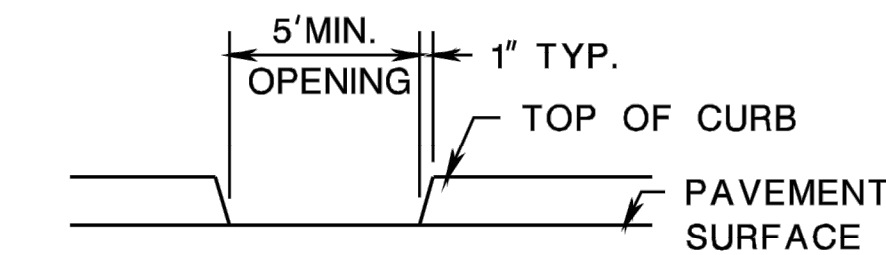

PEDESTRIAN REFUGE ISLAND WALKWAY OPENING AT INTERSECTIONS

NOTE:
5' MIN. WIDE OPENING TO BE FLUSH WITH ROADWAY PAVEMENT

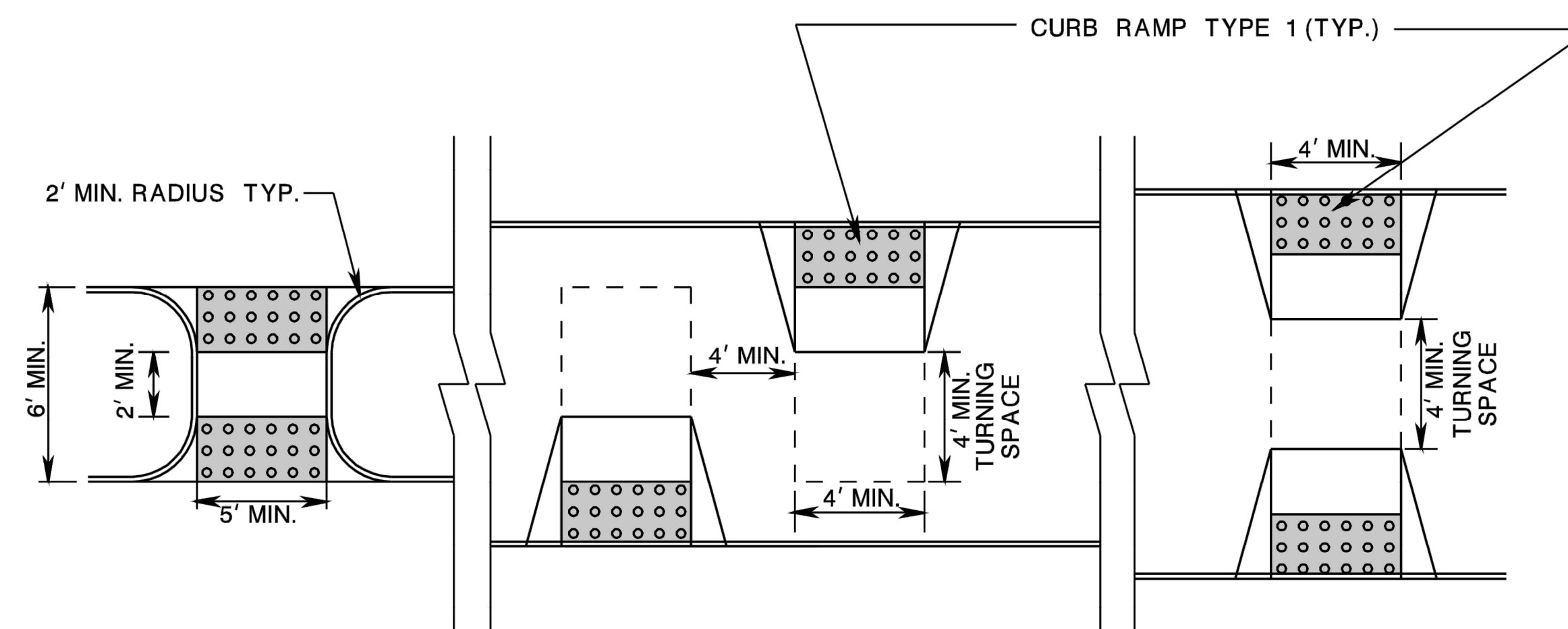

PEDESTRIAN REFUGE ISLAND

DETECTABLE WARNING SURFACE N.T.S.

- NOTES:**
- KEEP TURNING SPACE, APPROACH SIDEWALK TRANSITIONS, AND CURB RAMP CLEAR OF OBSTRUCTIONS THAT PROTRUDE ABOVE THE SURFACE.
 - CROSSWALKS AND STOP LINES MAY BE MARKED OR UNMARKED, SEE PLANS.
 - FOR NARROW ISLAND WIDTH, SEE PEDESTRIAN REFUGE ISLAND WALKWAY OPENING AT INTERSECTIONS DETAIL.
 - FOR MEDIUM AND LARGE ISLAND WIDTH, SEE CURB RAMP TYPE 1 ON CD-606-1.
 - CONSTRUCT CURB RAMP TYPES 1, 2, 3, 4, & 7 PERPENDICULAR TO CURBLINE, AS SHOWN.
 - IF A CURB RAMP IS REQUIRED, THE LOCATION OF THE DETECTABLE WARNING SURFACE MUST BE AT THE BOTTOM OF THE RAMP AND WITHIN THE REQUIRED DISTANCE FROM THE RAIL.
 - A STANDARD DETECTABLE WARNING (DWS) SURFACE IS NOT AVAILABLE TO FIT THIS APPLICATION, AND THEREFORE ONE WILL NEED TO BE CUSTOMIZED. THE DWS SHOULD COVER THE ENTIRE WIDTH OF THE RAMP. THE ROWS OF DOMES ON THE DWS SHOULD FOLLOW THE DIRECTION OF TRAVEL OF THE RAMP, SO PEDESTRIANS WHO USE MOBILE DEVICES CAN TRACK BETWEEN THE DOMES.

NEW JERSEY DEPARTMENT OF TRANSPORTATION

CONSTRUCTION DETAILS

CD-606-2

CD-606-2.1

pen table= \\NJDOTPRWS\Vsystem\NJDOTTWS\Projects\NJDOTEng\plan\TBLA\Roadway\Details_13x17.tbl

scale=63.073306:1.000000

date=28-SEP-2016 11:07

ID=TP2VILL

BDG606-01-ORIGINAL SHEET

file=

CURB RAMP TYPE 1

0.0 % GUTTER LINE PROFILE				
H INCHES	W FEET	X _{1U} FEET	X _{1L} FEET	L ₁ FEET
3	3	2.50	2.50	9.00
4	4	3.33	3.33	10.67
5	5	4.17	4.17	12.33
6	6	5.00	5.00	14.00
7	7	5.83	5.83	15.67
8	8	6.67	6.67	17.33
9	9	7.50	7.50	19.00

1.0 % GUTTER LINE PROFILE				
H INCHES	W FEET	X _{1U} FEET	X _{1L} FEET	L ₁ FEET
3	3	2.78	2.27	9.05
4	4	3.70	3.03	10.73
5	5	4.63	3.79	12.42
6	6	5.56	4.55	14.10
7	7	6.48	5.30	15.78
8	8	7.41	6.06	17.47
9	9	8.33	6.82	19.15

2.0 % GUTTER LINE PROFILE				
H INCHES	W FEET	X _{1U} FEET	X _{1L} FEET	L ₁ FEET
3	3	3.13	2.08	9.21
4	4	4.17	2.78	10.94
5	5	5.21	3.47	12.68
6	6	6.25	4.17	14.42
7	7	7.29	4.86	16.15
8	8	8.33	5.56	17.89
9	9	9.38	6.25	19.63

3.0 % GUTTER LINE PROFILE				
H INCHES	W FEET	X _{1U} FEET	X _{1L} FEET	L ₁ FEET
3	3	3.57	1.92	9.49
4	4	4.76	2.56	11.33
5	5	5.95	3.21	13.16
6	6	7.14	3.85	14.99
7	7	8.33	4.49	16.82
8	8	9.52	5.13	18.65
9	9	10.71	5.77	20.48

4.0 % GUTTER LINE PROFILE				
H INCHES	W FEET	X _{1U} FEET	X _{1L} FEET	L ₁ FEET
3	3	4.17	1.79	9.95
4	4	5.56	2.38	11.94
5	5	6.94	2.98	13.92
6	6	8.33	3.57	15.90
7	7	9.72	4.17	17.89
8	8	11.11	4.76	19.87
9	9	12.50	5.36	21.86

5.0 % GUTTER LINE PROFILE				
H INCHES	W FEET	X _{1U} FEET	X _{1L} FEET	L ₁ FEET
3	3	5.00	1.67	10.67
4	4	6.67	2.22	12.89
5	5	8.33	2.78	15.11
6	6	10.00	3.33	17.33
7	7	11.67	3.89	19.56
8	8	13.33	4.44	21.78
9	9	15.00	5.00	24.00

6.0 % GUTTER LINE PROFILE				
H INCHES	W FEET	X _{1U} FEET	X _{1L} FEET	L ₁ FEET
3	3	6.25	1.56	11.81
4	4	8.33	2.08	14.42
5	5	10.42	2.60	17.02
6	6	12.50	3.13	19.63
7	7	14.58	3.65	22.23
8	8	16.67	4.17	24.84
9	9	18.75	4.69	27.45

7.0 % GUTTER LINE PROFILE				
H INCHES	W FEET	X _{1U} FEET	X _{1L} FEET	L ₁ FEET
3	3	8.33	1.47	13.80
4	4	11.11	1.96	17.07
5	5	13.89	2.45	20.34
6	6	16.67	2.94	23.61
7	7	19.44	3.43	26.88
8	8	22.22	3.92	30.15
9	9	25.00	4.41	33.42

CURB RAMP TYPE 3

0.0 % GUTTER LINE PROFILE								
H INCHES	W FEET	X _{1U} FEET	X _{1L} FEET	L ₁ FEET	Y INCHES	X _{2U} FEET	X _{2L} FEET	L ₂ FEET
3	2.75	2.50	2.50	9.00	2.75	0.91	0.91	5.82
4	2.75	3.33	3.33	10.67	2.75	1.91	1.91	7.82
5	2.75	4.17	4.17	12.33	2.75	2.91	2.91	9.82
6	2.75	5.00	5.00	14.00	2.75	3.91	3.91	11.83
7	2.75	5.83	5.83	15.67	2.75	4.91	4.91	13.83
8	2.75	6.67	6.67	17.33	2.75	5.91	5.91	15.83
9	2.75	7.50	7.50	19.00	2.75	6.91	6.91	17.83

1.0 % GUTTER LINE PROFILE								
H INCHES	W FEET	X _{1U} FEET	X _{1L} FEET	L ₁ FEET	Y INCHES	X _{2U} FEET	X _{2L} FEET	L ₂ FEET
3	3.0	2.78	2.27	9.05	3.0	1.72	1.72	7.44
4	3.0	3.70	3.03	10.73	3.0	2.72	2.72	9.44
5	3.0	4.63	3.79	12.42	3.0	3.72	3.72	11.45
6	3.0	5.56	4.55	14.10	3.0	4.72	4.72	13.45
7	3.0	6.48	5.30	15.78	3.0	5.72	5.72	15.45
8	3.0	7.41	6.06	17.47	3.0	6.72	6.72	17.45
9	3.0	8.33	6.82	19.15	3.0	7.72	7.72	19.45

2.0 % GUTTER LINE PROFILE								
H INCHES	W FEET	X _{1U} FEET	X _{1L} FEET	L ₁ FEET	Y INCHES	X _{2U} FEET	X _{2L} FEET	L ₂ FEET
3	3.5	3.13	2.08	9.21	3.5	1.34	1.34	6.68
4	3.5	4.17	2.78	10.94	3.5	2.34	2.34	8.68
5	3.5	5.21	3.47	12.68	3.5	3.34	3.34	10.69
6	3.5	6.25	4.17	14.42	3.5	4.34	4.34	12.69
7	3.5	7.29	4.86	16.15	3.5	5.34	5.34	14.69
8	3.5	8.33	5.56	17.89	3.5	6.34	6.34	16.69
9	3.5	9.38	6.25	19.63	3.5	7.34	7.34	18.69

3.0 % GUTTER LINE PROFILE								
H INCHES	W FEET	X _{1U} FEET	X _{1L} FEET	L ₁ FEET	Y INCHES	X _{2U} FEET	X _{2L} FEET	L ₂ FEET
3	4.0	3.57	1.92	9.49	4.0	1.96	1.96	7.92
4	4.0	4.76	2.56	11.33	4.0	2.96	2.96	9.93
5	4.0	5.95	3.21	13.16	4.0	3.96	3.96	11.93
6	4.0	7.14	3.85	14.99	4.0	4.96	4.96	13.93
7	4.0	8.33	4.49	16.82	4.0	5.96	5.96	15.93
8	4.0	9.52	5.13	18.65	4.0	6.96	6.96	17.93
9	4.0	10.71	5.77	20.48	4.0	7.96	7.96	19.93

4.0 % GUTTER LINE PROFILE								
H INCHES	W FEET	X _{1U} FEET	X _{1L} FEET	L ₁ FEET	Y INCHES	X _{2U} FEET	X _{2L} FEET	L ₂ FEET
3	4.0	4.17	1.79	9.95	4.0	2.96	2.96	9.93
4	4.0	5.56	2.38	11.94	4.0	3.96	3.96	11.93
5	4.0	6.94	2.98	13.92	4.0	4.96	4.96	13.93
6	4.0	8.33	3.57	15.90	4.0	5.96	5.96	15.93
7	4.0	9.72	4.17	17.89	4.0	6.96	6.96	17.93
8	4.0	11.11	4.76	19.87	4.0	7.96	7.96	19.93
9	4.0	12.50	5.36	21.86	4.0	8.96	8.96	21.93

5.0 % GUTTER LINE PROFILE								
H INCHES	W FEET	X _{1U} FEET	X _{1L} FEET	L ₁ FEET	Y INCHES	X _{2U} FEET	X _{2L} FEET	L ₂ FEET
3	4.0	5.00	1.67	10.67	4.0	3.96	3.96	11.93
4	4.0	6.67	2.22	12.89	4.0	4.96	4.96	13.93
5	4.0	8.33	2.78	15.11	4.0	5.96	5.96	15.93
6	4.0	10.00	3.33	17.33	4.0	6.96	6.96	17.93
7	4.0	11.67	3.89	19.56	4.0	7.96	7.96	19.93
8	4.0	13.33	4.44	21.78	4.0	8.96	8.96	21.93
9	4.0	15.00	5.00	24.00	4.0	9.96	9.96	24.00

6.0 % GUTTER LINE PROFILE								
H INCHES	W FEET	X _{1U} FEET	X _{1L} FEET	L ₁ FEET	Y INCHES	X _{2U} FEET	X _{2L} FEET	L ₂ FEET
3	4.0	6.25	1.56	11.81	4.0	4.96	4.96	13.93
4	4.0	8.33	2.08	14.42	4.0	5.96	5.96	15.93
5	4.0	10.42	2.60	17.02	4.0	6.96	6.96	17.93
6	4.0	12.50	3.13	19.63	4.0	7.96	7.96	19.93
7	4.0	14.58	3.65	22.23	4.0	8.96	8.96	21.93
8	4.0	16.67	4.17	24.84	4.0	9.96	9.96	24.00
9	4.0	18.75	4.69	27.45	4.0	10.96	10.96	27.00

7.0 % GUTTER LINE PROFILE								
H INCHES	W FEET	X _{1U} FEET	X _{1L} FEET	L ₁ FEET	Y INCHES	X _{2U} FEET	X _{2L} FEET	L ₂ FEET
3	4.0	8.33	1.47	13.80	4.0	11.96	11.96	24.00
4	4.0	11.11	1.96	17.07	4.0	12.96	12.96	26.00
5	4.0	13.89	2.45	20.34	4.0	13.96	13.96	28.00
6	4.0	16.67	2.94	23.61	4.0	14.96	14.96	30.00
7	4.0	19.44	3.43	26.88	4.0	15.96	15.96	32.00
8	4.0	22.22	3.92	30.15	4.0	16.96	16.96	34.00
9	4.0	25.00	4.41	33.42	4.0	17.96	17.96	36.00

1.0 % GUTTER LINE PROFILE								
H INCHES	W FEET	X _{1U} FEET	X _{1L} FEET	L ₁ FEET	Y INCHES	X _{2U} FEET	X _{2L} FEET	L ₂ FEET
3	2.75	2.78	2.27	9.05	2.75	1.04	0.81	5.85
4	2.75	3.70	3.03	10.73	2.75	2.17	1.71	7.88
5	2.75	4.63	3.79	12.42	2.75	3.31	2.60	9.91
6	2.75	5.56	4.55	14.10	2.75	4.45	3.49	11.94
7	2.75	6.48	5.30	15.78	2.75	5.58	4.39	13.97
8	2.75	7.41	6.06	17.47	2.75	6.72	5.28	16.00
9	2.75	8.33	6.82	19.15	2.75	7.86	6.17	18.03

2.0 % GUTTER LINE PROFILE								
H INCHES	W FEET	X _{1U} FEET	X _{1L} FEET	L ₁ FEET	Y INCHES	X _{2U} FEET	X _{2L} FEET	L ₂ FEET
3	3.0	3.13	2.08	9.21	3.0	0.82	0.64	5.46
4	3.0	4.17	2.78	10.94	3.0	1.96	1.54	7.49
5	3.0	5.21	3.47	12.68	3.0	3.09	2.43	9.52
6	3.0	6.25	4.17	14.42	3.0	4.23	3.32	11.55
7	3.0	7.29	4.86	16.15	3.0	5.37	4.22	13.58
8	3.0	8.33	5.56	17.89	3.0	6.50	5.11	15.61
9	3.0	9.38	6.25	19.63	3.0	7.64	6.00	17.64

3.0 % GUTTER LINE PROFILE								
H INCHES	W FEET	X _{1U} FEET	X _{1L} FEET	L ₁ FEET	Y INCHES	X _{2U} FEET	X _{2L} FEET	L ₂ FEET
3	3.5	3.57	1.92	9.49	3.5	0.39	0.30	4.69
4	3.5	4.76	2.56	11.33	3.5	1.53	1.20	6.72
5	3.5	5.95	3.21	13.16	3.5	2.66	2.09	8.75
6	3.5	7.14	3.85	14.99	3.5	3.80	2.98	10.78
7	3.5	8.33	4.49	16.82	3.5	4.94	3.88	12.81

CURB RAMP TYPE 4

0.0 % GUTTER LINE PROFILE					
H INCHES	W FEET	Y INCHES	X _{2U} FEET	X _{2L} FEET	L ₂ FEET
3			0.91	0.91	5.82
4			1.91	1.91	7.82
5			2.91	2.91	9.82
6	2.75	2.75	3.91	3.91	11.82
7			4.91	4.91	13.83
8			5.91	5.91	15.83
9			6.91	6.91	17.83
3			**	**	**
4			1.72	1.72	7.44
5			2.72	2.72	9.44
6	3.0	3.0	3.72	3.72	11.45
7			4.72	4.72	13.45
8			5.72	5.72	15.45
9			6.72	6.72	17.45
3			**	**	**
4			1.34	1.34	6.68
5			2.34	2.34	8.68
6	3.5	3.5	3.34	3.34	10.69
7			4.34	4.34	12.69
8			5.34	5.34	14.69
9			6.34	6.34	16.69
3			**	**	**
4			**	**	**
5			1.96	1.96	7.92
6	4.0	4.0	2.96	2.96	9.93
7			3.96	3.96	11.93
8			4.96	4.96	13.93
9			5.96	5.96	15.93

1.0 % GUTTER LINE PROFILE					
H INCHES	W FEET	Y INCHES	X _{2U} FEET	X _{2L} FEET	L ₂ FEET
3			1.04	0.81	5.85
4			2.17	1.71	7.88
5			3.31	2.60	9.91
6	2.75	2.75	4.45	3.49	11.94
7			5.58	4.39	13.97
8			6.72	5.28	16.00
9			7.86	6.17	18.03
3			0.82	0.64	5.46
4			1.96	1.54	7.49
5			3.09	2.43	9.52
6	3.0	3.0	4.23	3.32	11.55
7			5.37	4.22	13.58
8			6.50	5.11	15.61
9			7.64	6.00	17.64
3			0.39	0.30	4.69
4			1.53	1.20	6.72
5			2.66	2.09	8.75
6	3.5	3.5	3.80	2.98	10.78
7			4.94	3.88	12.81
8			6.07	4.77	14.84
9			7.21	5.66	16.87
3			**	**	**
4			1.09	0.86	5.95
5			2.23	1.75	7.98
6	4.0	4.0	3.37	2.65	10.01
7			4.50	3.54	12.04
8			5.64	4.43	14.07
9			6.78	5.32	16.10

2.0 % GUTTER LINE PROFILE					
H INCHES	W FEET	Y INCHES	X _{2U} FEET	X _{2L} FEET	L ₂ FEET
3			1.20	0.73	5.93
4			2.52	1.54	8.06
5			3.83	2.35	10.18
6	2.75	2.75	5.15	3.16	12.30
7			6.47	3.96	14.43
8			7.78	4.77	16.55
9			9.10	5.58	18.67
3			0.95	0.58	5.53
4			2.27	1.39	7.65
5			3.58	2.20	9.78
6	3.0	3.0	4.90	3.00	11.90
7			6.22	3.81	14.02
8			7.53	4.62	16.15
9			8.85	5.42	18.27
3			0.45	0.28	4.72
4			1.77	1.08	6.85
5			3.08	1.89	8.97
6	3.5	3.5	4.40	2.70	11.09
7			5.72	3.50	13.22
8			7.03	4.31	15.34
9			8.35	5.12	17.46
3			**	**	**
4			1.27	0.78	6.04
5			2.58	1.58	8.16
6	4.0	4.0	3.90	2.39	10.29
7			5.22	3.20	12.41
8			6.53	4.00	14.53
9			7.85	4.81	16.66

3.0 % GUTTER LINE PROFILE					
H INCHES	W FEET	Y INCHES	X _{2U} FEET	X _{2L} FEET	L ₂ FEET
3			1.42	0.67	6.09
4			2.99	1.41	8.39
5			4.55	2.14	10.69
6	2.75	2.75	6.11	2.88	12.99
7			7.68	3.61	15.29
8			9.24	4.35	17.59
9			10.81	5.08	19.89
3			1.13	0.53	5.66
4			2.69	1.27	7.96
5			4.25	2.00	10.26
6	3.0	3.0	5.82	2.74	12.55
7			7.38	3.47	14.85
8			8.94	4.21	17.15
9			10.51	4.94	19.45
3			0.53	0.25	4.78
4			2.10	0.99	7.08
5			3.66	1.72	9.38
6	3.5	3.5	5.22	2.46	11.68
7			6.79	3.19	13.98
8			8.35	3.93	16.28
9			9.91	4.66	18.58
3			**	**	**
4			1.50	0.71	6.21
5			3.07	1.44	8.51
6	4.0	4.0	4.63	2.18	10.81
7			6.19	2.91	13.11
8			7.76	3.65	15.41
9			9.32	4.38	17.71

CURB RAMP TYPE 7

0.0 % GUTTER LINE PROFILE				
H INCHES	W FEET	X _{1U} FEET	X _{1L} FEET	L ₁ FEET
3		3.00	3.00	10.00
4		4.00	4.00	12.00
5	4' MIN.	5.00	5.00	14.00
6	7' MAX.	6.00	6.00	16.00
7		7.00	7.00	18.01
8		8.00	8.00	20.01
9		9.00	9.00	22.01

4.0 % GUTTER LINE PROFILE				
H INCHES	W FEET	X _{1U} FEET	X _{1L} FEET	L ₁ FEET
3		5.77	2.03	11.80
4		7.70	2.70	14.40
5	4' MIN.	9.62	3.38	17.00
6	7' MAX.	11.55	4.06	19.60
7		13.47	4.73	22.20
8		15.40	5.41	24.80
9		17.32	6.08	27.40

1.0 % GUTTER LINE PROFILE				
H INCHES	W FEET	X _{1U} FEET	X _{1L} FEET	L ₁ FEET
3		3.41	2.68	10.09
4		4.55	3.57	12.12
5	4' MIN.	5.68	4.47	14.15
6	7' MAX.	6.82	5.36	16.18
7		7.96	6.25	18.21
8		9.10	7.15	20.24
9		10.23	8.04	22.27

5.0 % GUTTER LINE PROFILE				
H INCHES	W FEET	X _{1U} FEET	X _{1L} FEET	L ₁ FEET
3		7.51	1.88	13.38
4		10.01	2.50	16.51
5	4' MIN.	12.51	3.13	19.64
6	7' MAX.	15.00	3.75	22.75
7		15.00	4.38	23.38
8		15.00	5.00	24.00
9		15.00	5.63	24.63

2.0 % GUTTER LINE PROFILE				
H INCHES	W FEET	X _{1U} FEET	X _{1L} FEET	L ₁ FEET
3		3.95	2.42	10.37
4		5.27	3.23	12.49
5	4' MIN.	6.58	4.03	14.62
6	7' MAX.	7.90	4.84	16.74
7		9.22	5.65	18.86
8		10.53	6.45	20.99
9		11.85	7.26	23.11

6.0 % GUTTER LINE PROFILE				
H INCHES	W FEET	X _{1U} FEET	X _{1L} FEET	L ₁ FEET
3		10.73	1.74	16.47
4		14.31	2.33	20.63
5	4' MIN.	15.00	2.91	21.91
6	7' MAX.	15.00	3.49	22.49
7		15.00	4.07	23.07
8		15.00	4.65	23.65
9		15.00	5.23	24.23

4.0 % GUTTER LINE PROFILE					
H INCHES	W FEET	Y INCHES	X _{2U} FEET	X _{2L} FEET	L ₂ FEET
3			1.75	0.62	6.37
4			3.68	1.29	8.97
5			5.60	1.97	11.57
6	2.75	2.75	7.53	2.64	14.17
7			9.45	3.32	16.77
8			11.38	4.00	19.37
9			13.30	4.67	21.97
3			1.39	0.49	5.88
4			3.31	1.16	8.48
5			5.24	1.84	11.08
6	3.0	3.0	7.16	2.52	13.68
7			9.09	3.19	16.28
8			11.01	3.87	18.88
9			12.94	4.54	21.48
3			0.66	0.23	4.89
4			2.58	0.91	7.49
5			4.51	1.58	10.09
6	3.5	3.5	6.43	2.26	12.69
7			8.36	2.93	15.29
8			10.28	3.61	17.89
9			12.20	4.29	20.49
3			**	**	**
4			1.85	0.65	6.50
5			3.78	1.33	9.10
6	4.0	4.0	5.70	2.00	11.70
7			7.62	2.68	14.30
8			9.55	3.35	16.90
9			11.47	4.03	19.50

5.0 % GUTTER LINE PROFILE					
H INCHES	W FEET	Y INCHES	X _{2U} FEET	X _{2L} FEET	L ₂ FEET
3			2.28	0.57	6.85
4			4.78	1.19	9.98
5			7.29	1.82	13.10
6	2.75	2.75	9.79	2.45	16.23
7			12.29	3.07	19.36
8			14.79	3.70	22.49
9			17.29	4.32	25.62
3			1.80	0.45	6.26
4			4.31	1.08	9.38
5			6.81	1.70	12.51
6	3.0	3.0	9.31	2.33	15.64
7			11.81	2.95	18.77
8			14.32	3.58	21.89
9			16.82	4.20	25.02
3			0.85	0.21	5.07
4			3.36	0.84	8.20
5			5.86	1.46	11.32
6	3.5	3.5	8.36	2.09	14.45
7			10.86	2.71	17.58
8			13.37	3.34	20.71
9			15.87	3.96	23.84
3			**	**	**
4			2.41	0.60	7.01
5			4.91	1.23	10.14
6	4.0	4.0	7.41	1.85	13.26
7			9.91	2.48	16.39
8			12.42	3.10	19.52
9			14.92	3.73	22.65

6.0 % GUTTER LINE PROFILE					
H INCHES	W FEET	Y INCHES	X _{2U} FEET	X _{2L} FEET	L ₂ FEET
3			3.26	0.53	7.79
4			6.84	1.11	11.95
5			10.41	1.69	16.10
6	2.75	2.75	13.99	2.27	20.26
7			17.57	2.86	24.43
8			21.15	3.44	28.59
9			24.73	4.02	32.75
3			2.58	0.42	7.00
4			6.16	1.00	

THE LOUIS BERGER GROUP - Feb. 10, 2014 - 12:39pm - CAD FILE: L:\TRANS\CP-2011\CCC 1283 Elizabeth Signs\CAD\DWGS\08-Construction Details\08.dwg

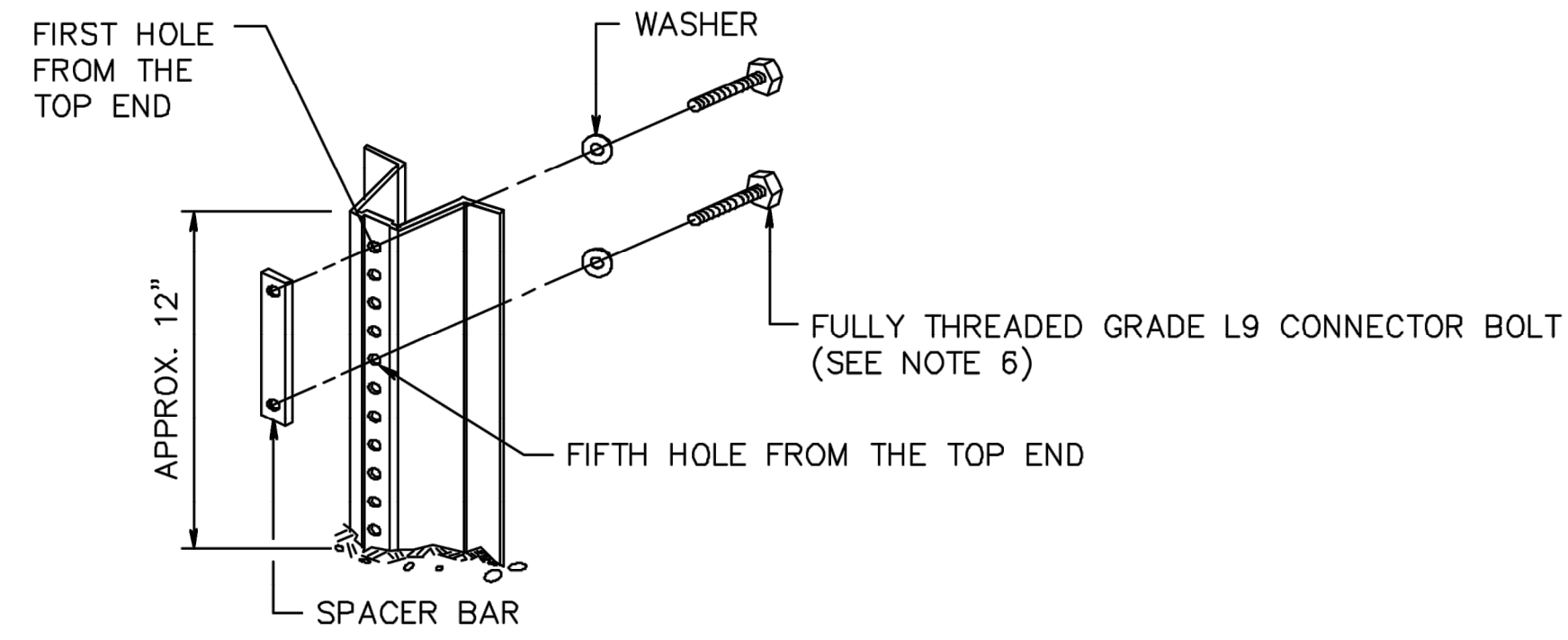

NOTES:

1. DRIVE ANCHOR POST ASSEMBLY TO WITHIN APPROXIMATELY 12 INCHES ABOVE GROUND LEVEL. PLACE BOLT AND WASHER IN FIRST AND FIFTH HOLES FROM THE TOP END, AND SECURE BOLTS ONTO SPACER BAR.
2. DRIVE ANCHOR POST ASSEMBLY TO WITHIN A MAXIMUM OF 4 INCHES ABOVE GROUND LEVEL.
3. DIG OUT AROUND BACK OF ANCHOR POST ASSEMBLY TO ALLOW ROOM FOR TOP POST TO BE ATTACHED.
4. NEST TOP POST ASSEMBLY ONTO PROTRUDING ANCHOR POST ASSEMBLY BOLTS, THROUGH THE FIRST AND FIFTH HOLES FROM THE BOTTOM OF THE TOP POST.
5. PLACE AND TIGHTEN A SELF-LOCKING FLANGE NUT ON EACH BOLT. WHEN INSTALLATION IS COMPLETE, TOP OF GROUND POST SHALL NOT EXCEED 4 INCHES ABOVE GROUND LEVEL.
6. SIZE OF CONNECTOR BOLT FOR TYPE 1, $\frac{5}{16}$ " x $1\frac{1}{2}$ "
SIZE OF CONNECTOR BOLT FOR TYPE 2, $\frac{3}{16}$ " x 2"
7. THE CONNECTOR BOLTS SHALL BE FULLY THREADED. EACH CONNECTOR BOLT AND NUT SHALL BE CLEARLY STAMPED WITH MANUFACTURER'S IDENTIFYING MARK.

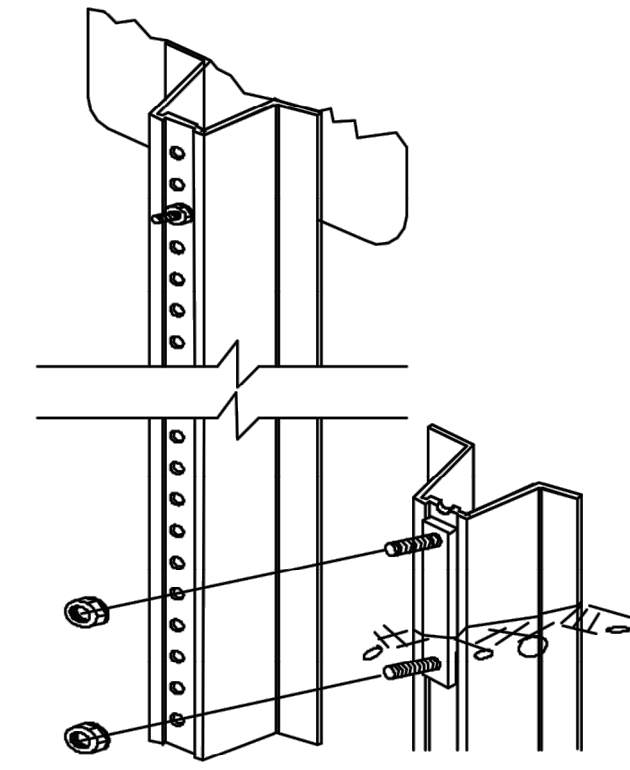
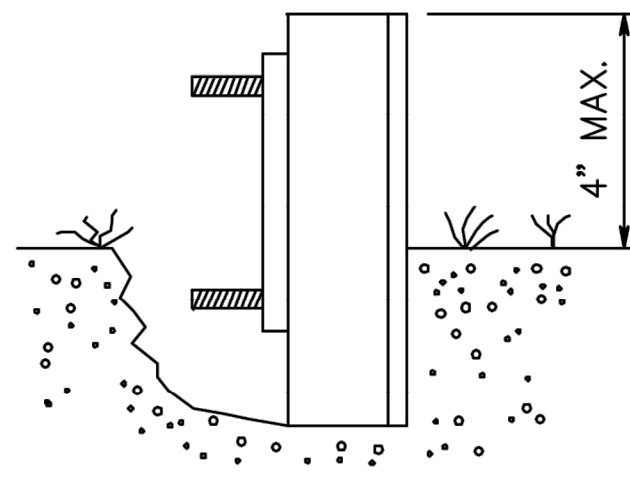

**ANCHOR POST ASSEMBLY
SIGN SUPPORTS**

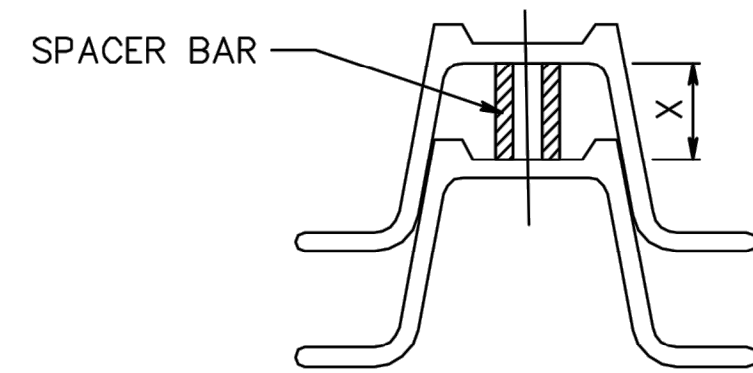
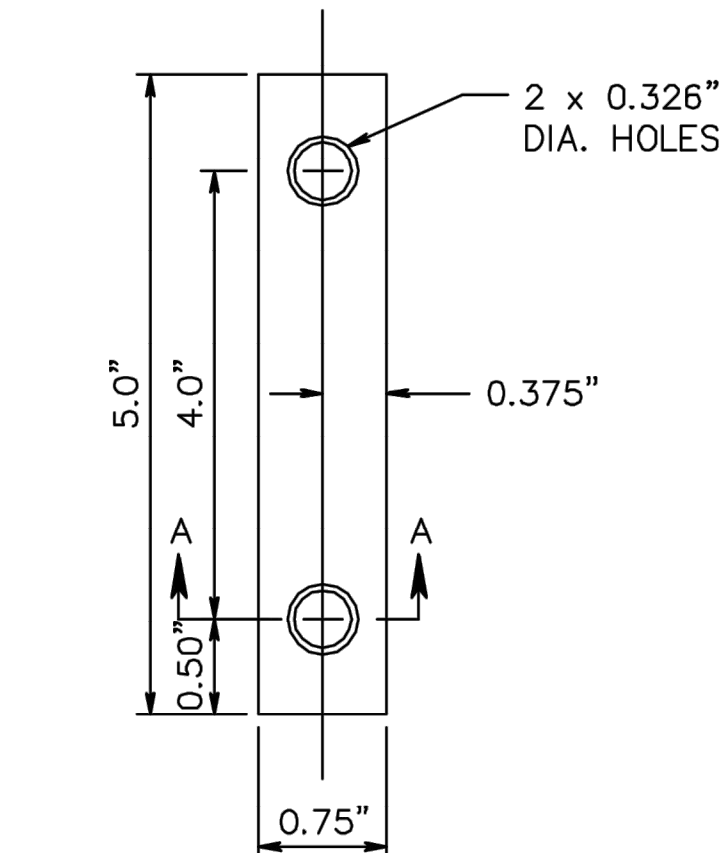

WHEN X IS GREATER THAN 0.75", USE TYPE 1 SPACER BAR
WHEN X IS 0.75" OR LESS, USE TYPE 2 SPACER BAR

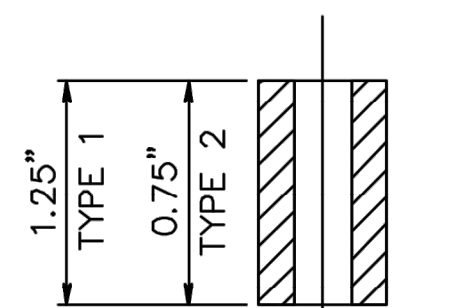

SECTION A-A

SPACER BAR

WEIGHT * LBS. / FT.	DIMENSIONS (IN)				AREA IN. 2	X-X AXIS **		Y-Y AXIS	
	"A"	"B"	"C"	"D"		I(IN. 4)	S(IN. 3)	I(IN. 4)	S(IN. 3)
2.50	1.516	3.062	1.278	0.669	0.760	0.228	0.313	0.539	0.352
4.00	1.968	3.500	1.336	0.834	1.187	0.611	0.707	1.161	0.664

* ± 5%
** GOVERNING SECTION

TYPE 1 STEEL U-POST PROPERTIES

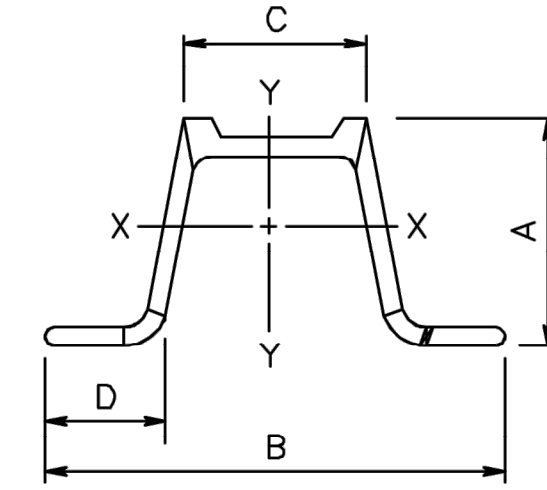

**TYPE 1 STEEL
U-POST**

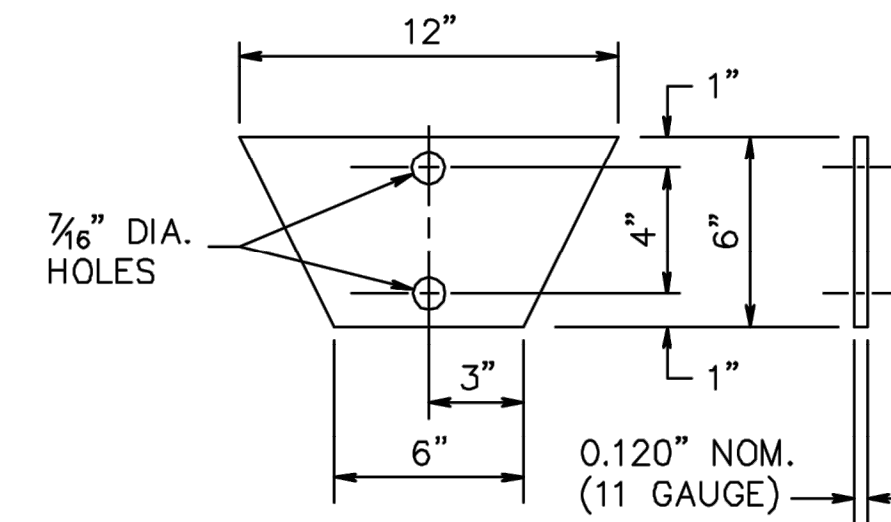

**TYPE 1
SOIL ANCHOR PLATE**

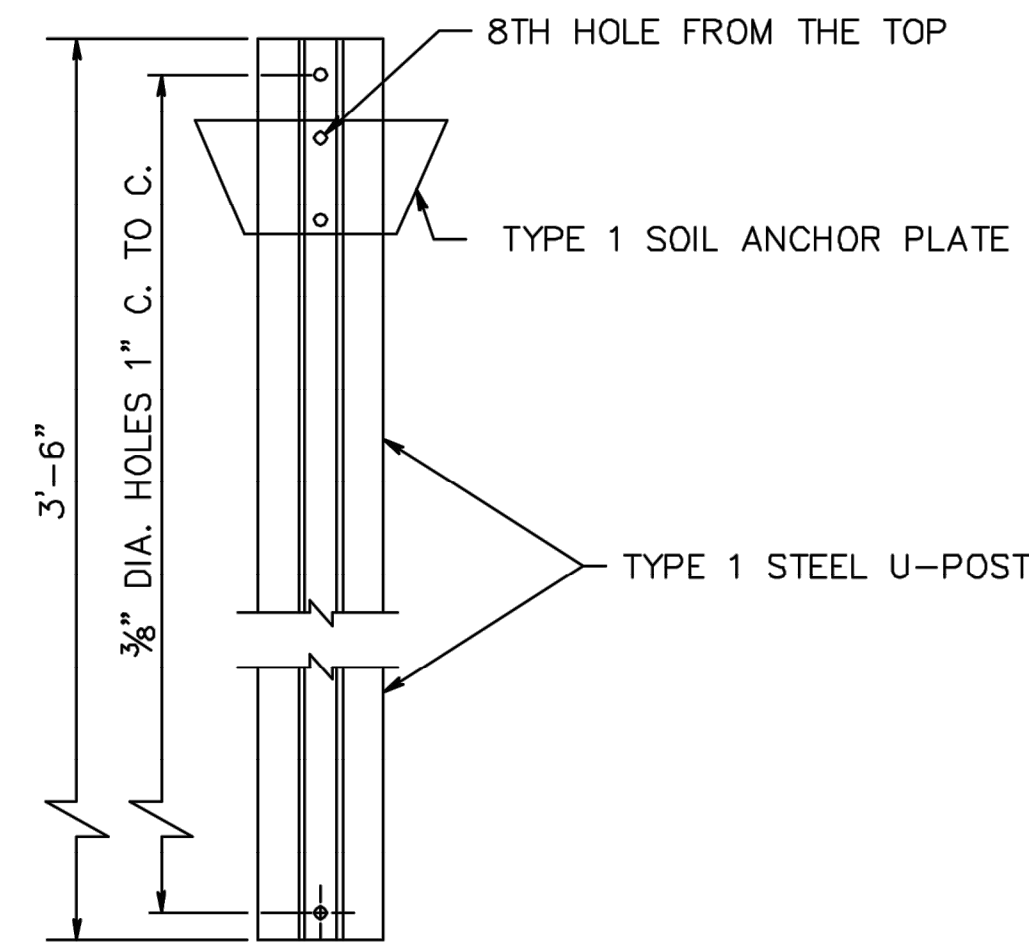

**TYPE 1
ANCHOR POST
ASSEMBLY**

WEIGHT * LBS. / FT.	DIMENSIONS (IN)				AREA IN. 2	X-X AXIS **		Y-Y AXIS	
	"A"	"B"	"C"	"D"		I(IN. 4)	S(IN. 3)	I(IN. 4)	S(IN. 3)
2.50	1.549	3.125	1.250	0.625	0.748	0.233	0.289	0.551	0.353
4.00	1.845	3.500	1.625	0.718	1.190	0.500	0.560	1.190	0.690

* ± 5%
** GOVERNING SECTION

TYPE 2 STEEL U-POST PROPERTIES

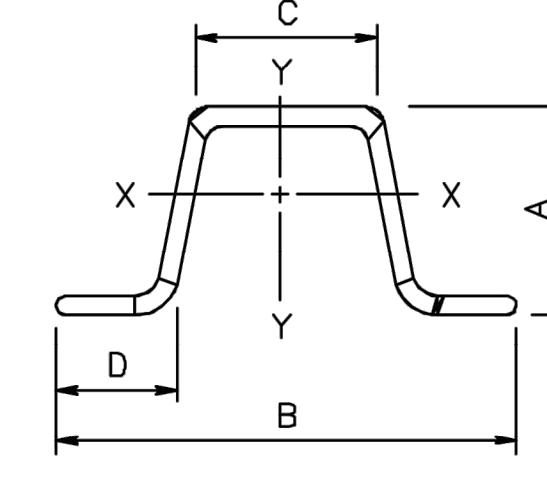

**TYPE 2 STEEL
U-POST**

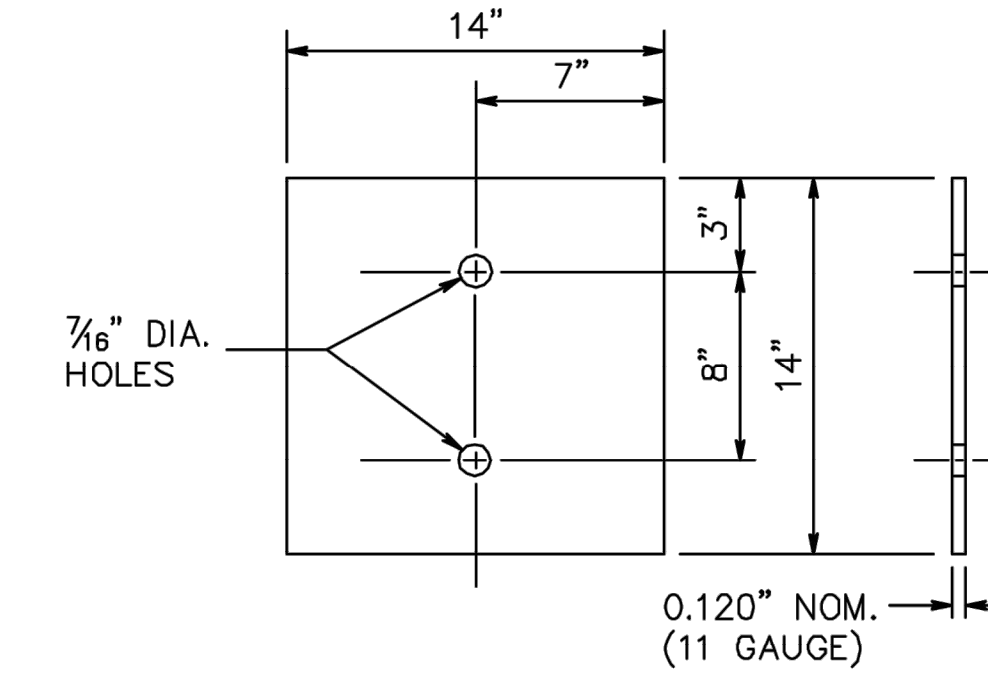

**TYPE 2
SOIL ANCHOR PLATE**

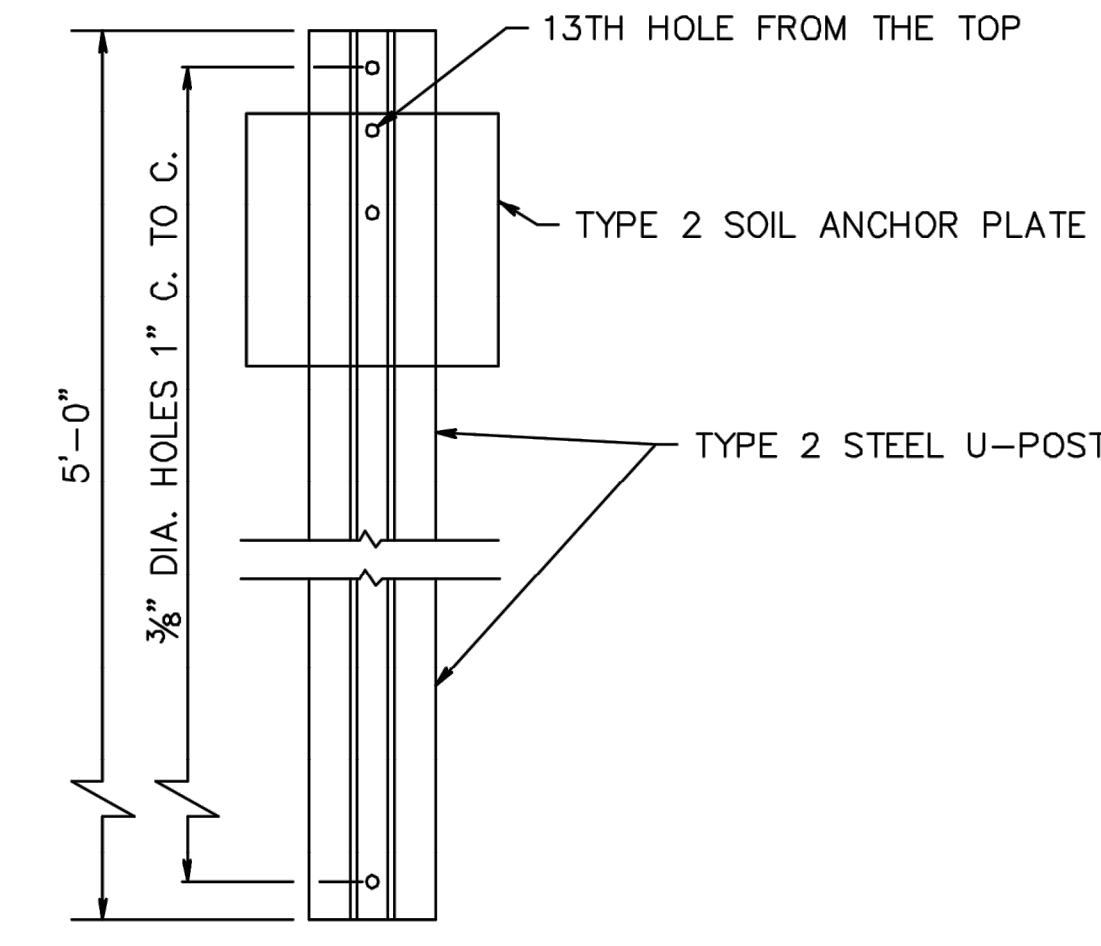

**TYPE 2
ANCHOR POST
ASSEMBLY**

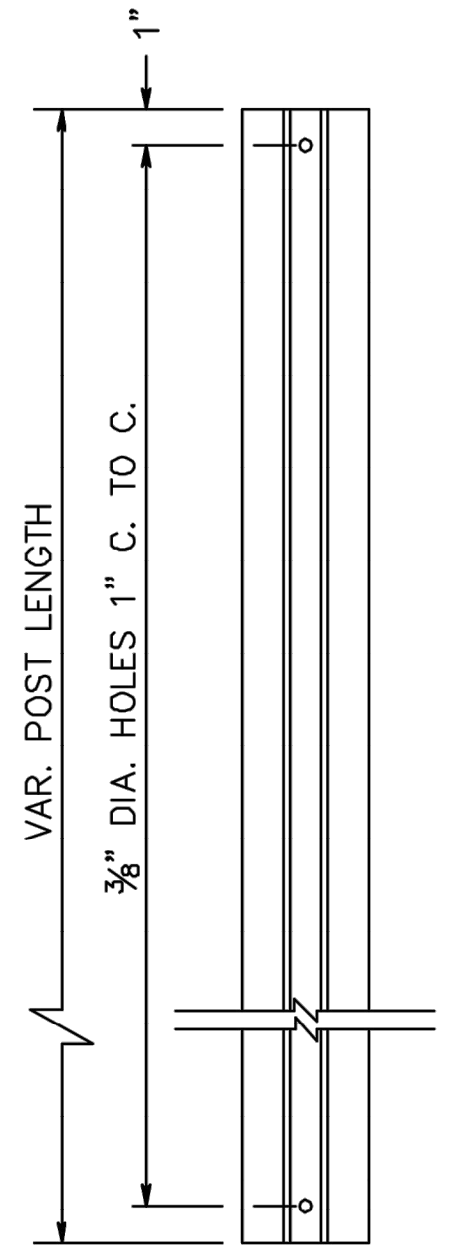

**TOP POST
U-POST**

**STEEL POSTS, POST CLIPS, SPACING,
ETC.
AND TWO PIECE STEEL U-POSTS.**

NOTES:

1. ANCHOR POST AND TOP POST SHALL BE OF EQUAL WEIGHT/FEET.
2. SOIL ANCHOR PLATE SHALL BE ATTACHED TO ALL ANCHOR POSTS.
3. THE MATERIAL FOR THE SOIL ANCHOR PLATES SHALL BE CARBON SHEET STEEL.
4. THE STEEL "U" POST SHALL BE GRADE 60.

REVISION	BY C'K'D	DATE
UNION COUNTY, DIVISION OF ENGINEERING		
CONSTRUCTION DETAILS POST DETAILS		
COUNTY OF UNION 2325 SOUTH AVENUE SCOTCH PLAINS, NJ 07076	SHEET NO. 17 OF 31	

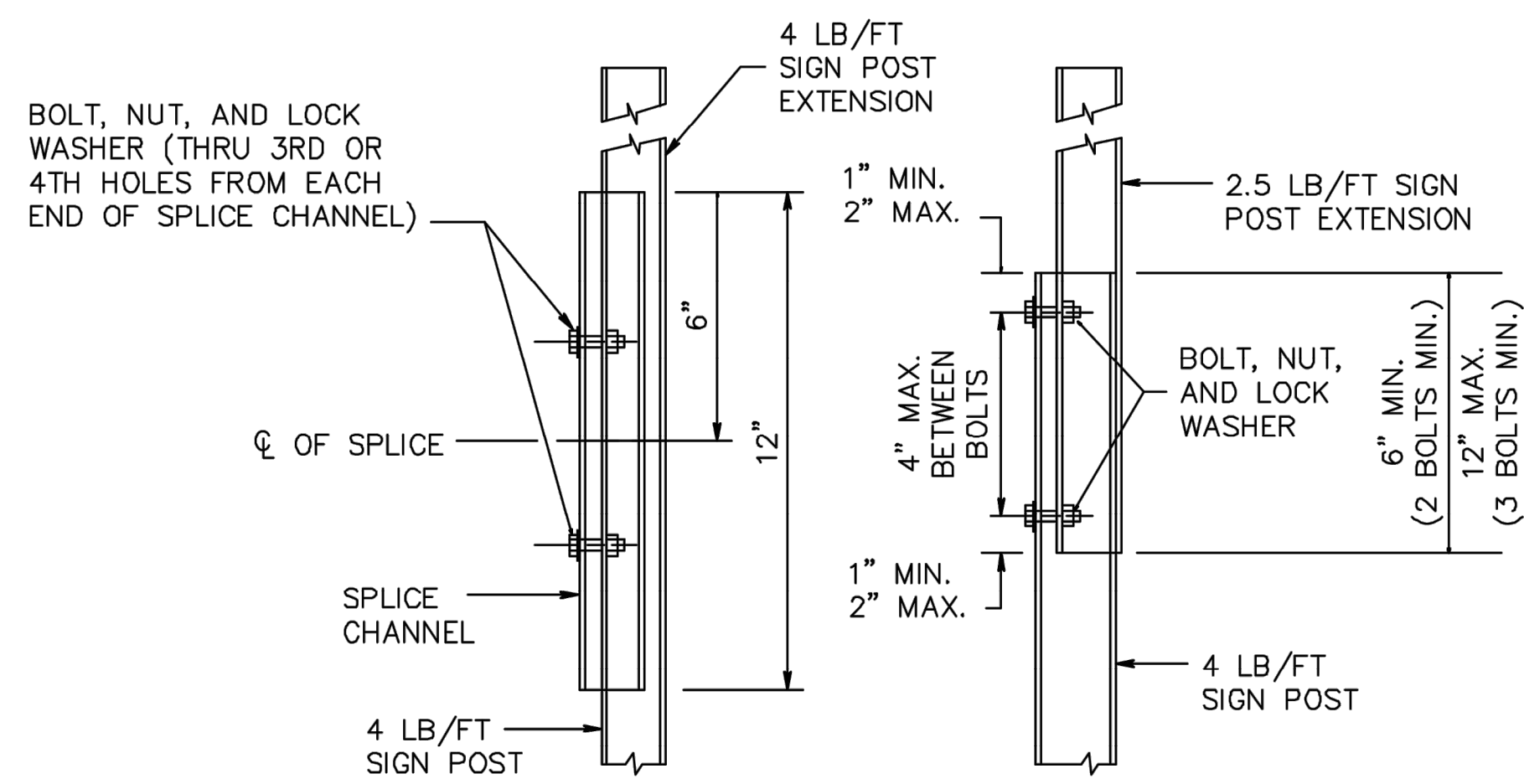

**SIGN POST EXTENSION
SPLICE DETAILS**

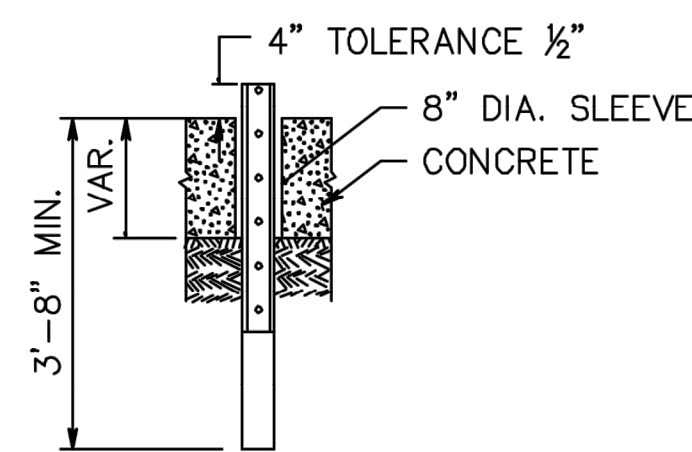

**CONCRETE
INSTALLATION**

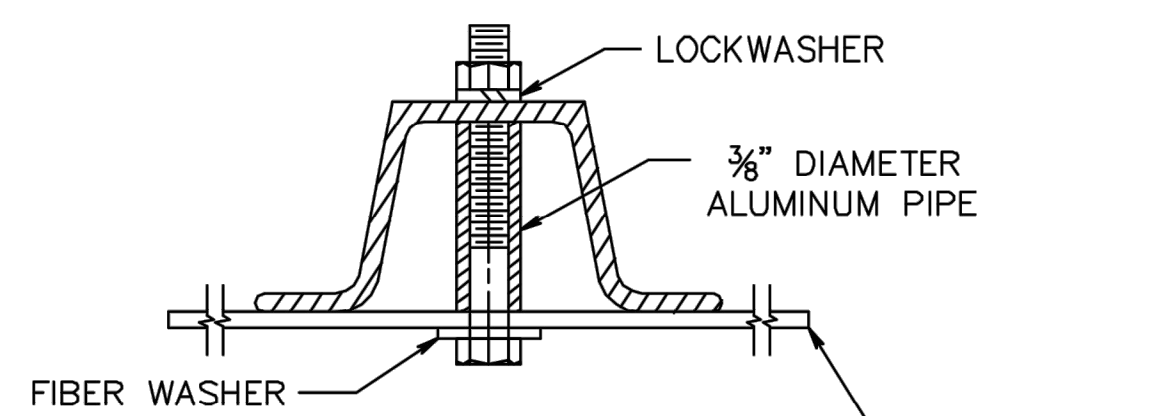

FRONT MOUNT BRACKET

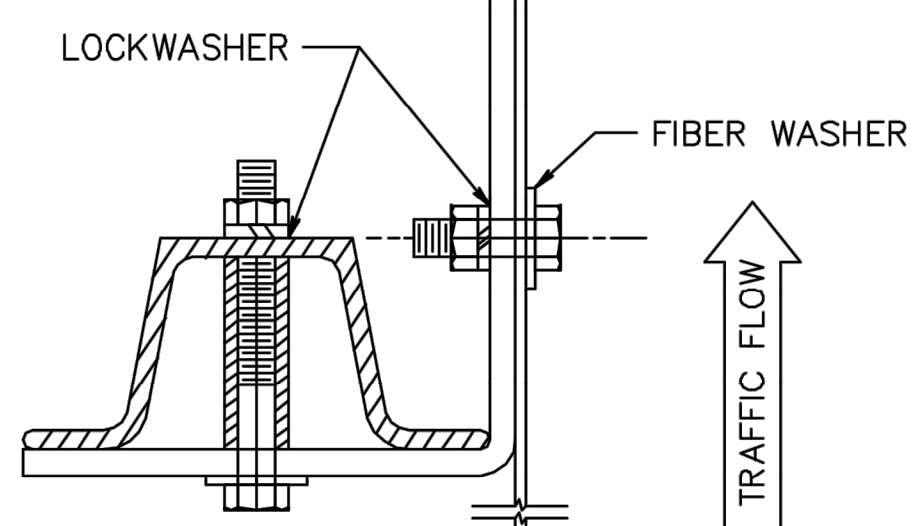

SIDE MOUNT BRACKET

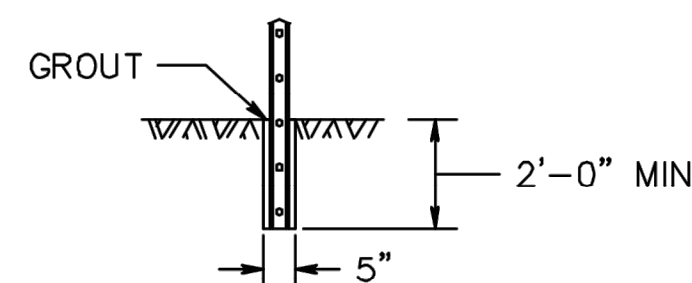

**ROCK
INSTALLATION**

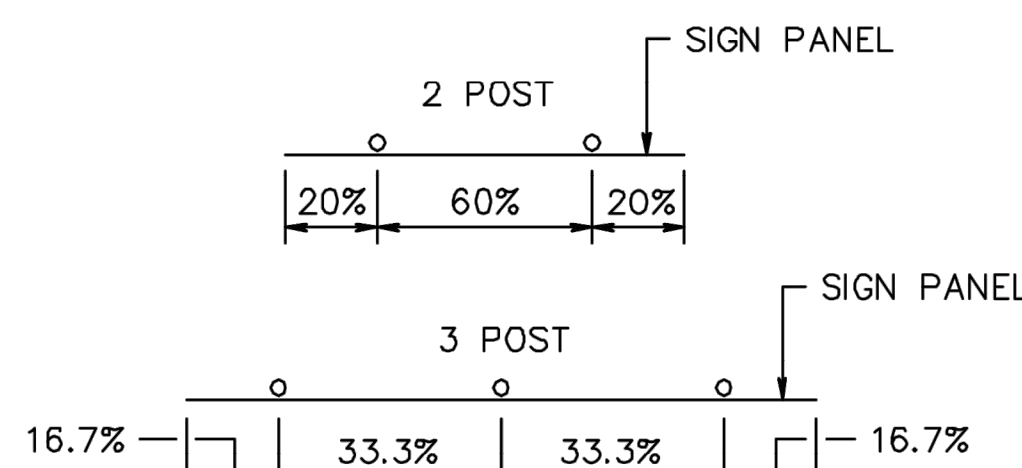

STEEL U-POST SPACING

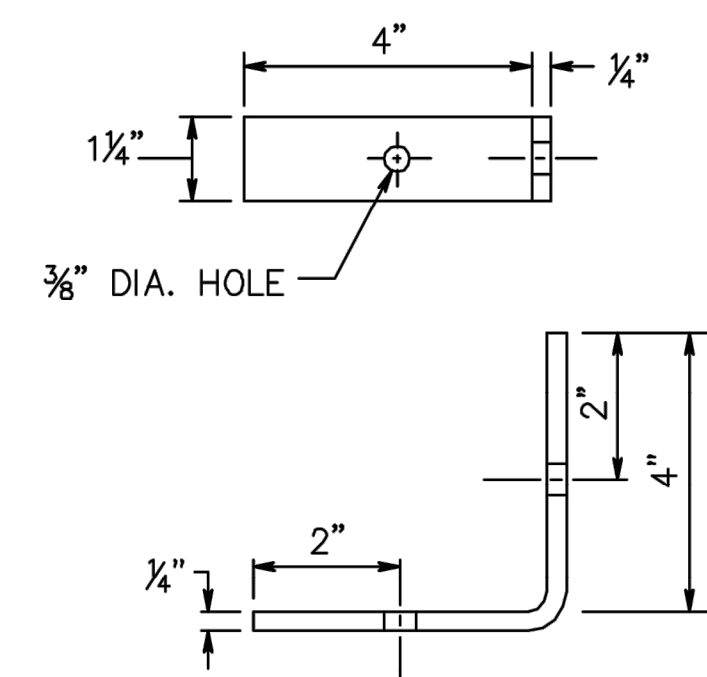

**DETAIL OF BRACKET
FOR SIDE MOUNTED SIGNS**

PANEL SIZE (W x H)	# OF POSTS	POST SIZE (LB/ FT)
18" x 18"	1	2.5
18" x 24"	1	2.5
24" x 24"	1	2.5
24" x 30"	1	2.5
24" x 36"	1	2.5
30" x 24"	1	2.5
30" x 30"	1	2.5
36" x 12"	2	2.5
36" x 36" x 36"	2	2.5
30" x 36"	1	4.0

PANEL SIZE (W x H)	# OF POSTS	POST SIZE (LB/ FT)
36" x 36"	2	2.5
36" x 48"	2	2.5
45" x 36"	2	2.5
48" x 24"	2	2.5
48" x 36"	2	2.5
48" x 48"	2	4.0
48" x 64" x 64"	2	2.5
60" x 36"	2	4.0
48" x 60"	2	4.0
60" x 30"	2	4.0

**U-POST SELECTION TABLE
BREAKAWAY SIGN SUPPORT**

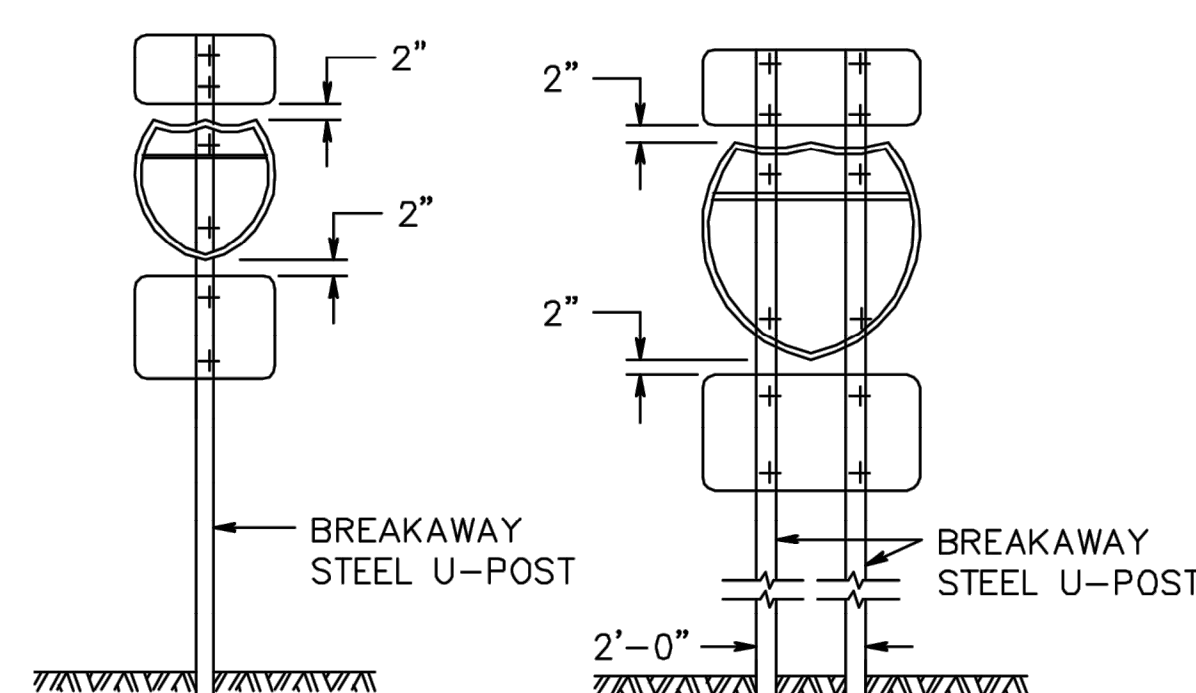

**24" x 24"
SHIELD**

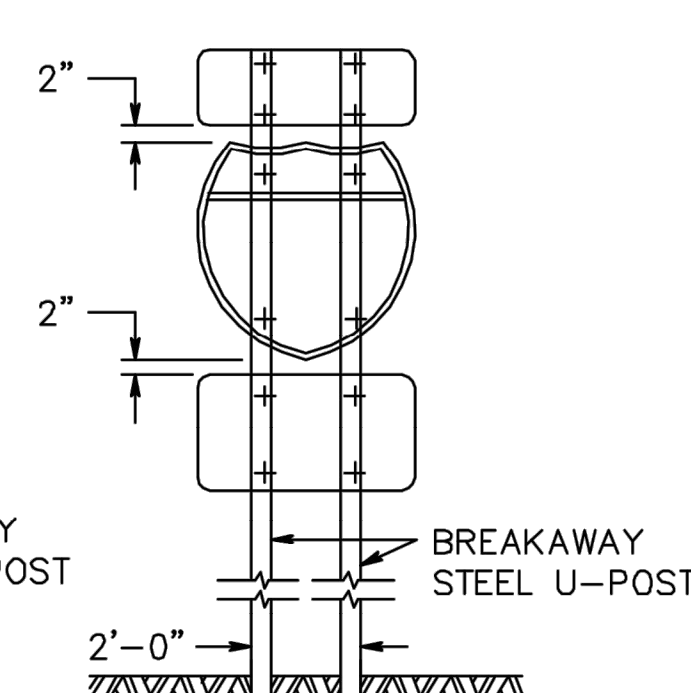

**36" x 36"
SHIELD**

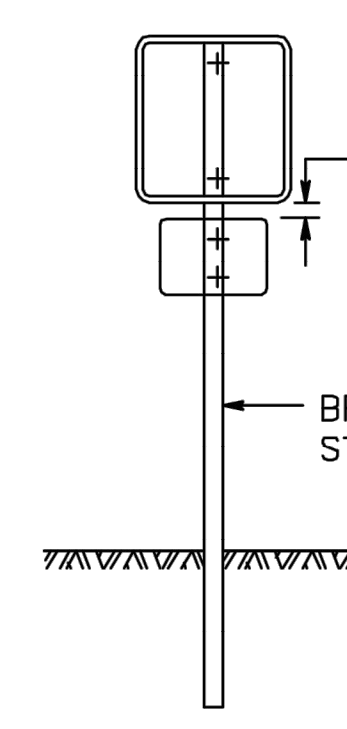

**30" x 30"
OR
SMALLER**

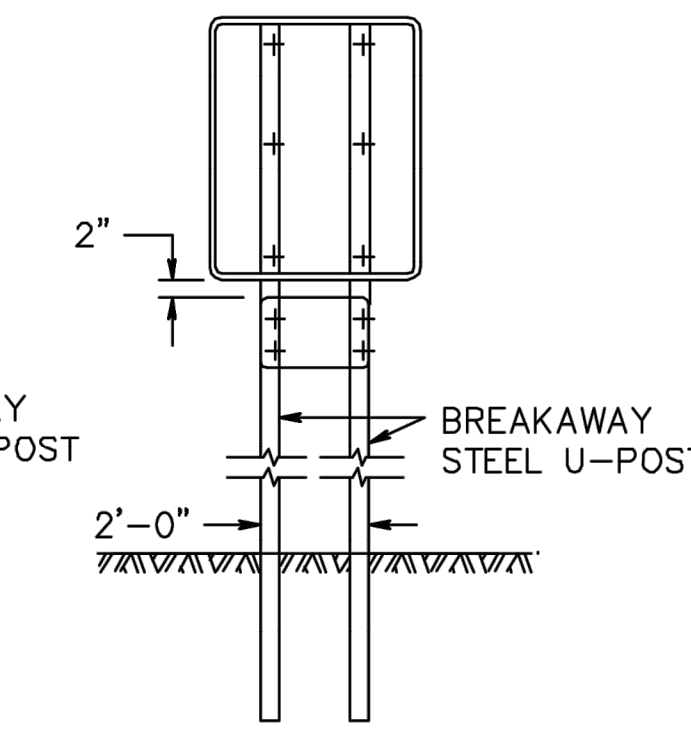

**36" x 36"
OR
LARGER**

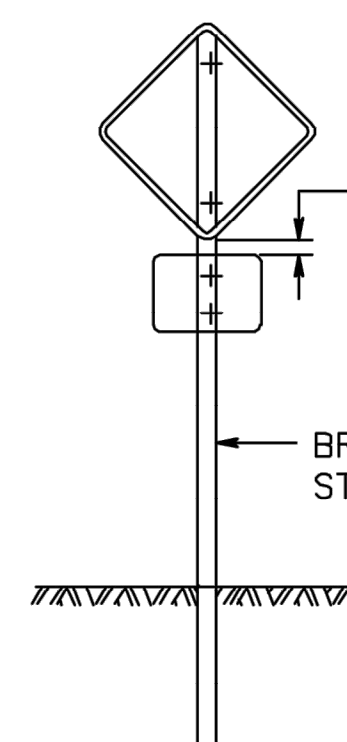

**30" x 30"
OR
SMALLER**

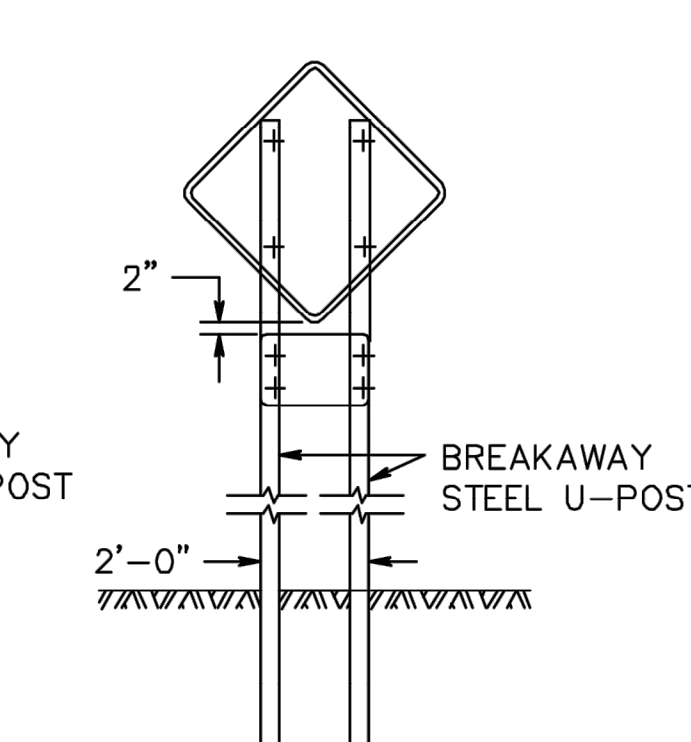

**36" x 36"
OR
LARGER**

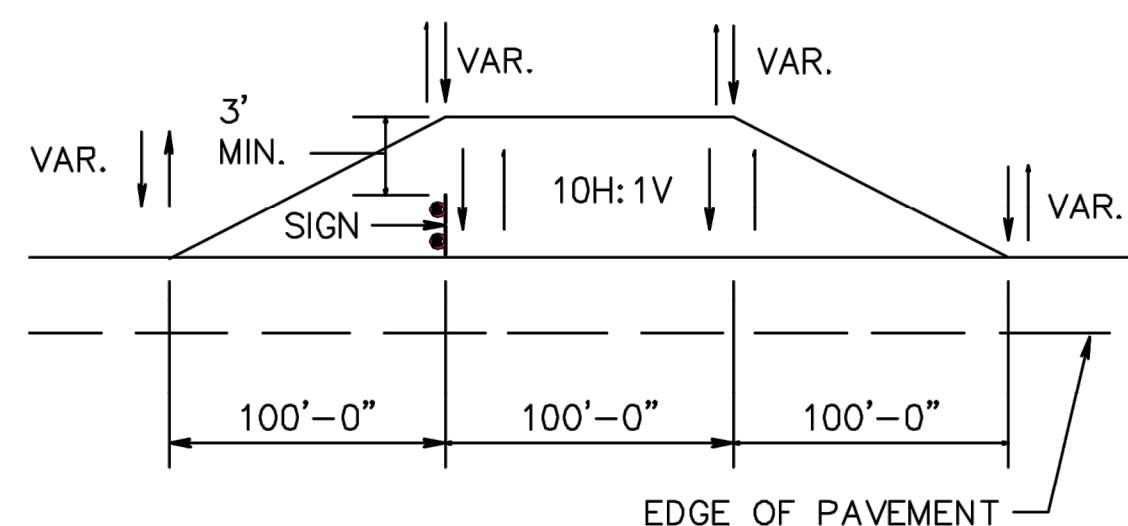

STEEL U-POST GRADING DETAIL

GENERAL NOTES:

1. ALL POSTS SHALL BE OF ADEQUATE LENGTH TO MEET THE REQUIREMENTS FOR ERECTION AS STATED IN THE CURRENT "MANUAL ON UNIFORM TRAFFIC CONTROL DEVICES FOR STREETS AND HIGHWAYS" AND AS INDICATED BELOW.
2. ALL SMALL SIGN SUPPORTS SHALL BE OF THE BREAKAWAY TYPE WITH EXCEPTION OF THOSE INSTALLED BEHIND GUIDE RAIL OR OTHER ROADSIDE BARRIER.
3. ALL STEEL POSTS AND BRACKETS SHALL BE CUT, BENT, AND HOLES PUNCHED AND DRILLED BEFORE GALVANIZING. GALVANIZING SHALL BE IN CONFORMANCE WITH ASTM A123.
4. ALL STEEL U-POST SIGN SUPPORTS MUST BE INSTALLED FACING THE PREDOMINANT TRAFFIC FLOW. A MOUNTING BRACKET SHOULD BE USED ON SIDE MOUNTED SIGNS SUCH AS "ONE WAY" SIGNS INSTALLED IN MEDIANS.
5. SIGN PANEL SIZES SHALL DETERMINE POST TYPE AND NUMBER AS SHOWN ON THIS DETAIL.
6. BOLTS SHALL NOT PROTRUDE MORE THAN 3/4" BEYOND THE NUT WHEN TIGHT, BUT SHALL ENGAGE ALL THREADS IN THE NUT.
7. WHEN SIGNS ARE INSTALLED ON SLOPES 10H:1V OR FLATTER, THE MINIMUM VERTICAL CLEARANCE REQUIREMENTS FOR SIGNS ARE:

FOR SINGLE POST INSTALLATIONS - THE MINIMUM DISTANCE BETWEEN THE EDGE OF THE PAVEMENT AND THE BOTTOM OF ANY PANEL MUST BE 7 FEET, AND THE MINIMUM DISTANCE FROM EDGE OF PAVEMENT TO THE TOP OF ANY SIGN PANEL MUST BE 9 FEET.

FOR MULTI-POST INSTALLATIONS - THE MINIMUM DISTANCE BETWEEN THE EDGE OF THE PAVEMENT AND THE BOTTOM OF A MAJOR SIGN PANEL MUST BE 7 FEET.

SECONDARY SIGN PANELS (LAND SERVICE HIGHWAYS) - THE MINIMUM DISTANCE BETWEEN THE EDGE OF PAVEMENT AND THE BOTTOM OF A SECONDARY SIGN PANEL IS 6 FEET.

SECONDARY SIGN PANELS (INTERSTATE AND FREEWAYS) - THE BOTTOM OF THE MAJOR SIGN SHALL BE A MINIMUM OF 8 FEET AND THE SECONDARY SIGN PANEL A MINIMUM OF 5 FEET ABOVE THE EDGE OF PAVEMENT.

WHERE GRADING OF 10H:1V OR FLATTER CANNOT BE OBTAINED, OR WHERE CURB OR BERM IS GREATER THAN 4 INCHES, THE MINIMUM VERTICAL CLEARANCE WILL BE MEASURED FROM THE GROUND LINE TO THE BOTTOM OF THE SIGN.

8. PERMANENT SIGN SUPPORTS SHOULD NOT BE INSTALLED ON SLOPES GREATER THAN 10H:1V, EXCEPT WHERE GRADING OF 10H:1V CANNOT BE OBTAINED OR THE SIGN SUPPORTS WILL BE BEHIND A TRAFFIC BARRIER. THE SLOPE SHALL EXTEND A MINIMUM OF 3 FEET BEYOND THE OUTSIDE EDGE OF SIGN (SEE GRADING DETAIL FOR SLOPE TREATMENT).
9. EXTRUDED ALUMINUM SIGN PANELS ARE NOT PERMITTED FOR USE WITH STEEL U-POST SIGN SUPPORTS.
10. STEEL U-POST SIGN SUPPORTS SHALL NOT BE PLACED IN FRONT OF GUIDE RAIL AND THE POSTS MUST NOT STRADDLE GUIDE RAIL.
11. TO EXTEND THE HEIGHT OF A SIGN POST, A MAXIMUM OF ONE SPLICE MAY BE MADE AND MUST BE A MINIMUM OF 9 FEET FROM THE GROUNDLINE TO CENTER LINE OF SPLICE.

REVISION	BY	DATE
UNION COUNTY, DIVISION OF ENGINEERING		

**CONSTRUCTION DETAILS
SIGNING AND SIGN POSTS**

DRUMS SHALL BE MADE OF ORANGE PLASTIC WITH A MINIMUM OF FOUR ALTERNATE FLUORESCENT ORANGE AND WHITE RETROREFLECTIVE STRIPES. IF THERE ARE NON-REFLECTORIZED SPACES BETWEEN THE STRIPES, THEY SHALL BE NO MORE THAN 2" WIDE. RETROREFLECTIVE SHEETING FOR STRIPES SHALL CONFORM WITH ASTM D 4956 TYPE VII OR VIII WITH S2 REQUIREMENTS. THE TOP OF THE DRUM SHALL NOT BE OPEN. DRUMS SHALL BE CONSTRUCTED TO INHIBIT ROLLING IF KNOCKED OVER. THE REFLECTORIZED AREA OF DRUMS SHALL BE ROUND EXCEPT THAT OTHER SHAPES, WHICH PROVIDE THE SAME VISIBILITY AS AN 18 INCH DIAMETER ROUND DRUM REGARDLESS OF ORIENTATION, MAY BE USED.

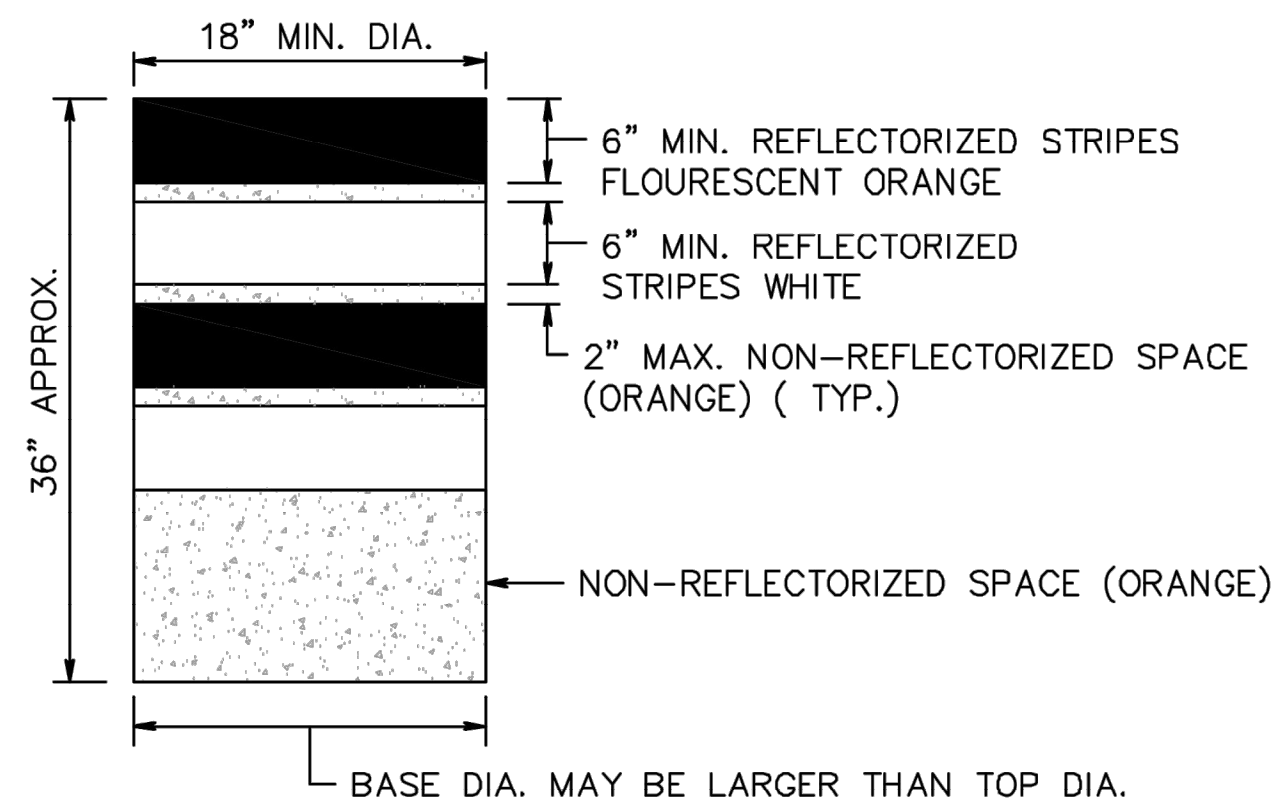

WHEN BALLAST IS REQUIRED BY THE R.E., SAND SHALL BE USED. THE MAXIMUM WEIGHT OF THE BALLAST SHALL BE 50 LBS. AND BE LOCATED APPROXIMATELY AT GROUND LEVEL. ALTERNATE TYPES OF BALLAST SHALL BE APPROVED BY THE R.E..

DRUMS

NOTES:

TRAFFIC CONES SHALL BE PREDOMINATELY ORANGE IN COLOR.

BASES MAY BE OF BREAKAWAY BALLASTED TYPE.

MINOR MANUFACTURER'S VARIATIONS MAY BE ACCEPTABLE UPON APPROVAL OF THE ENGINEER.

TRAFFIC CONES

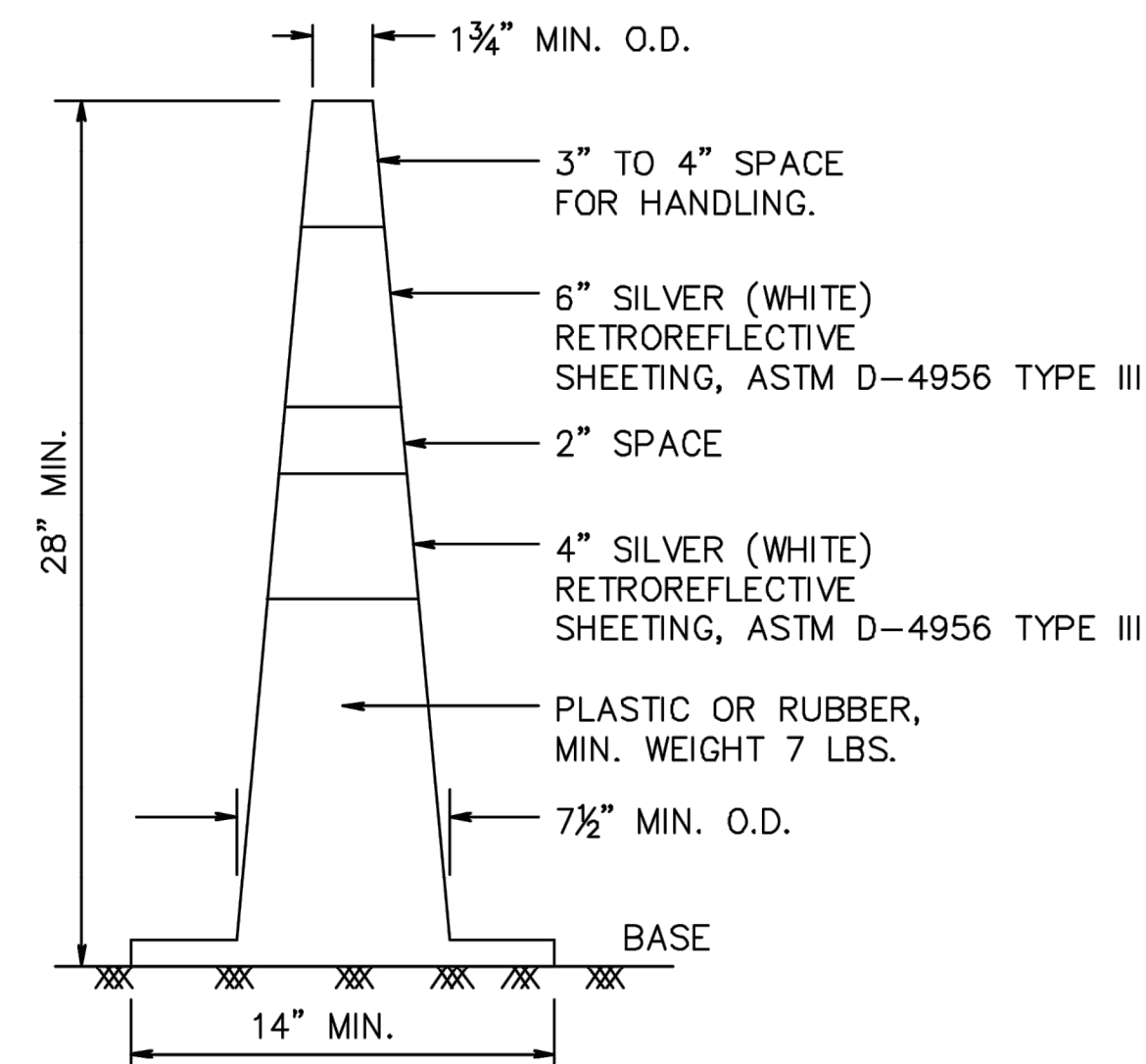

NOTES:

1. THE 9" MIN. x 48", OR 12" MAX. x 48" BARRICADE RAILS SHALL BE FABRICATED FROM 0.125" MAX. PLASTIC SHEETING AND SHALL BE ATTACHED, 4 PER RAIL, WITH 1 INCH NO. 14 PAN HEAD METAL SCREWS OR PLASTIC RIVETS. ALL CORNERS SHALL BE ROUNDED.
2. ORANGE AND SILVER (WHITE) STRIPES SHALL BE RETROREFLECTIVE SHEETING, ASTM D 4956 TYPE III, AS SHOWN FOR CONSTRUCTION SIGNS. ALTERNATE ORANGE AND SILVER (WHITE) STRIPES 6" WIDE SLOPING DOWNWARD AT AN ANGLE OF 45 DEGREES IN THE DIRECTION TRAFFIC IS TO PASS.
3. IF NECESSARY, THE SANDBAGS SHALL BE FABRICATED AND PLACED ACCORDING TO THE MANUFACTURE'S RECOMMENDATION.
4. THE FRAMING FOR BARRICADE PANELS SHALL BE NCHRP-350 CRASHED TESTED AND FHWA APPROVED.

BREAKAWAY BARRICADES

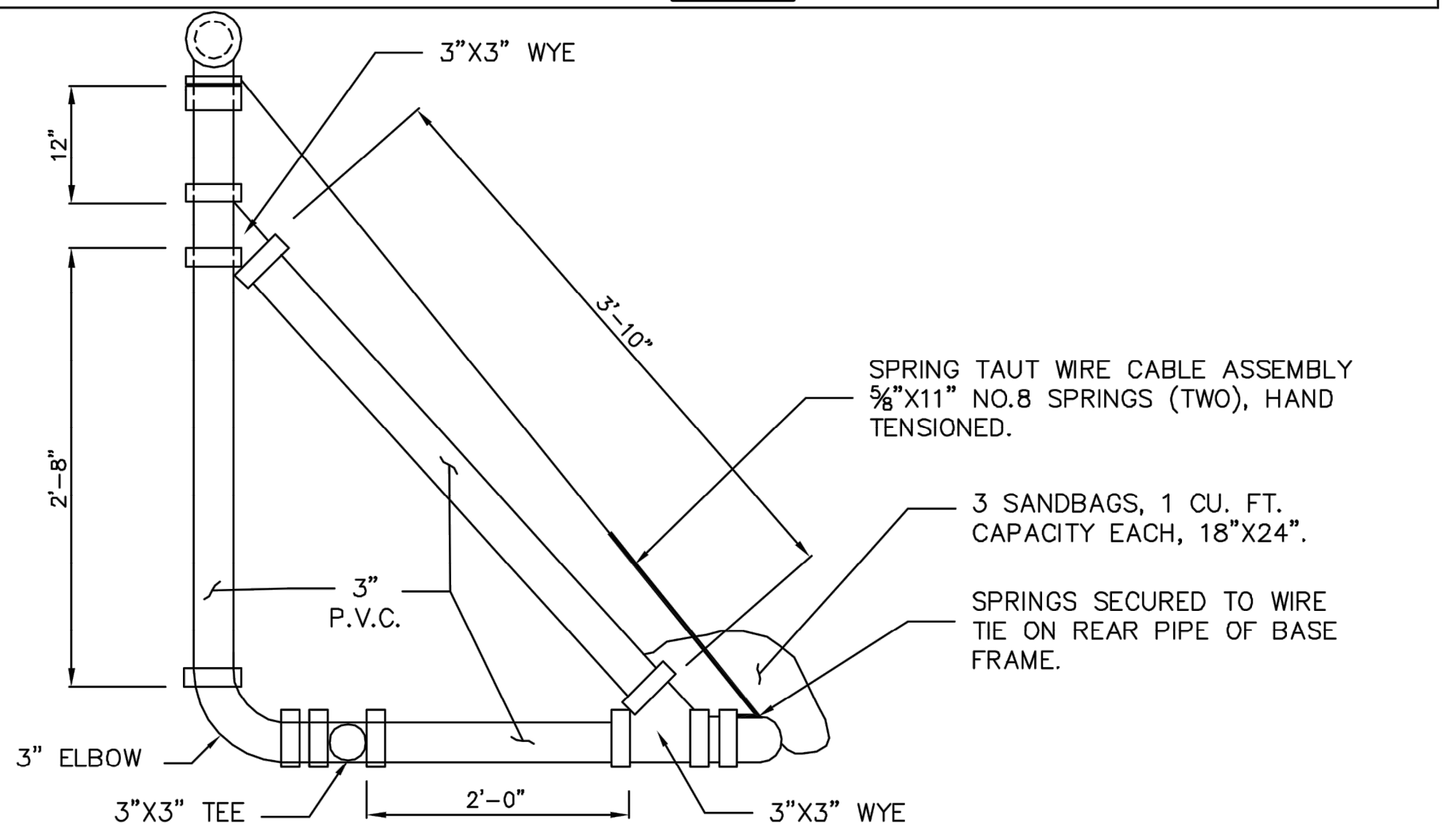

SIDE VIEW

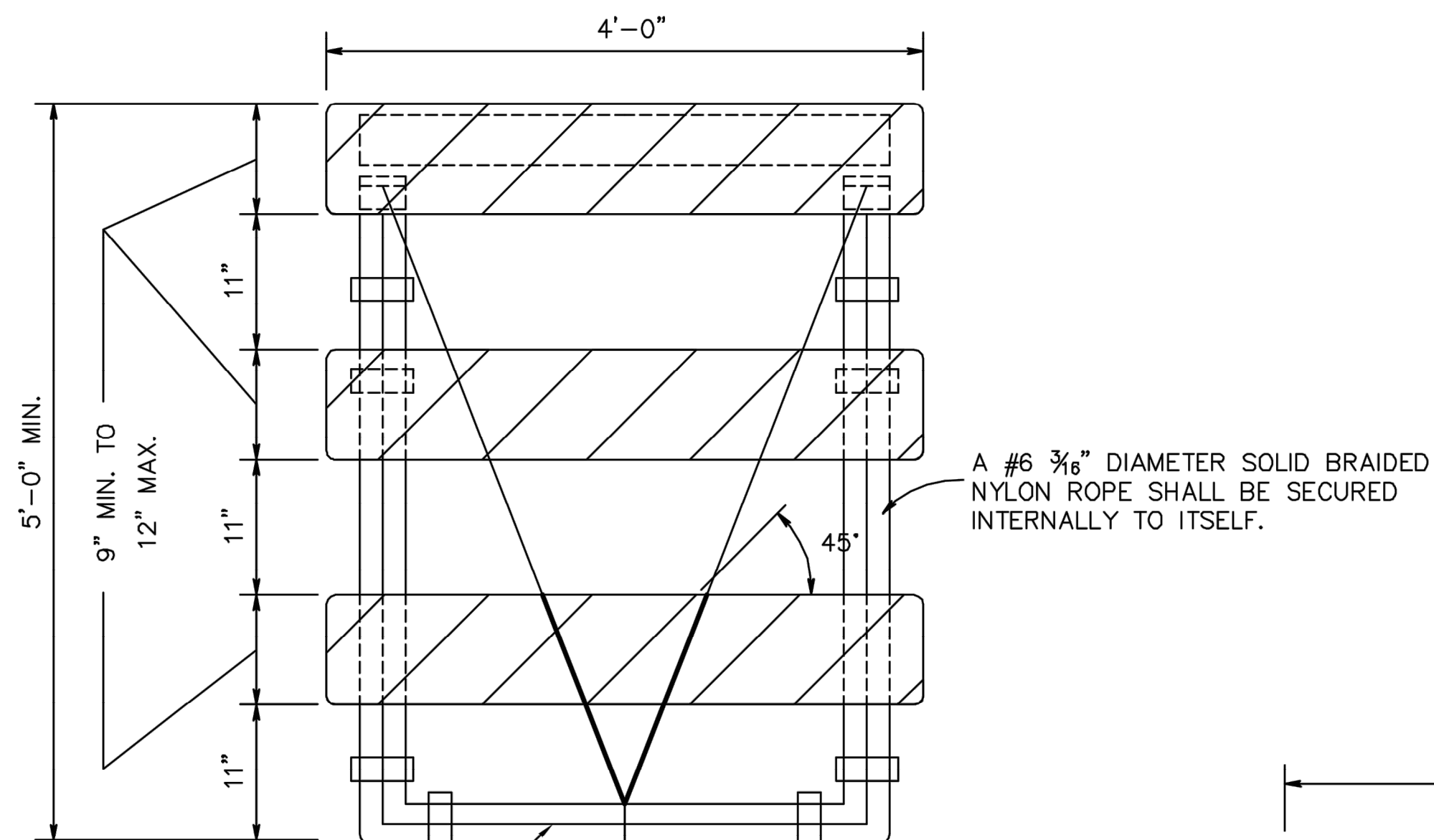

FRONT VIEW

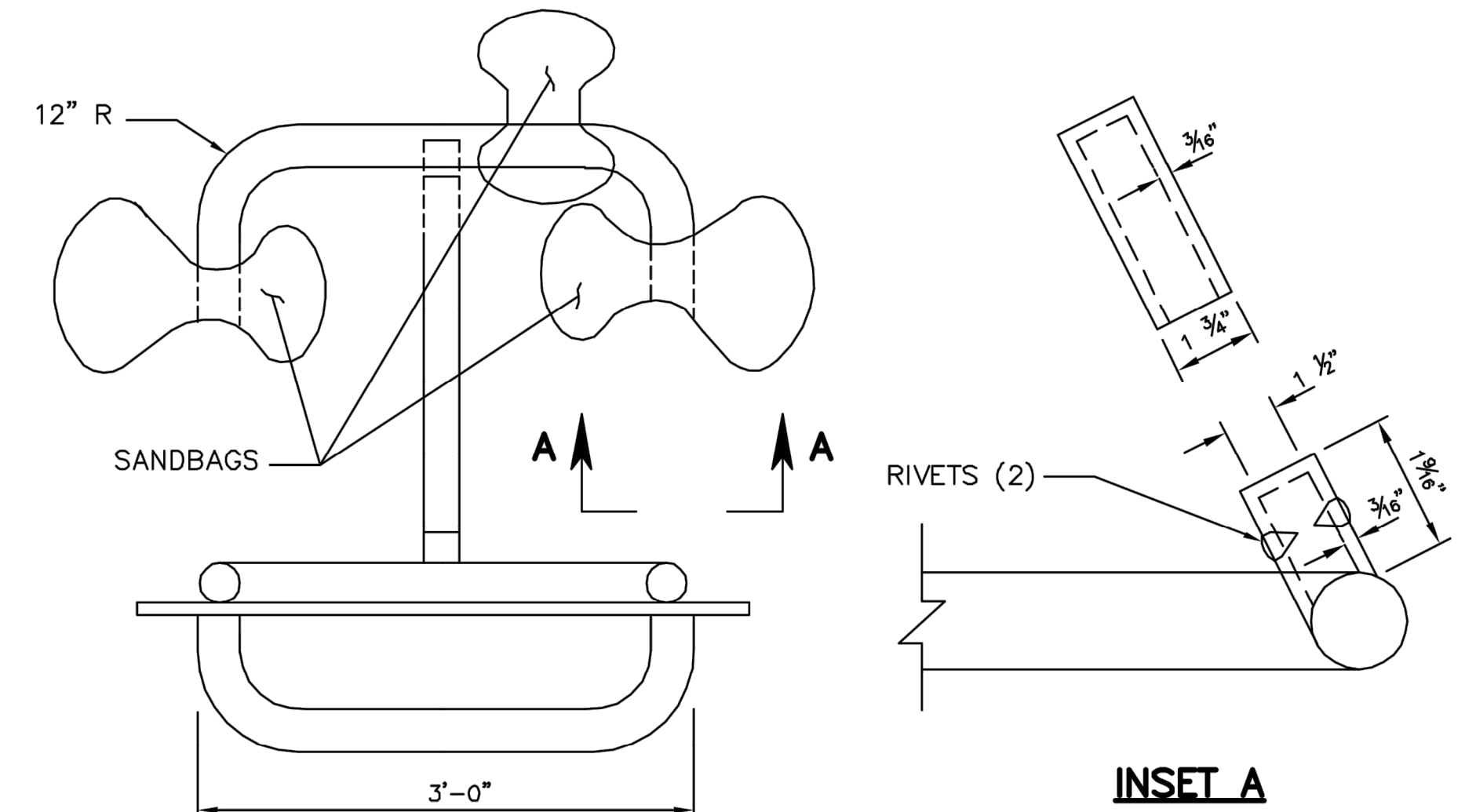

INSET A

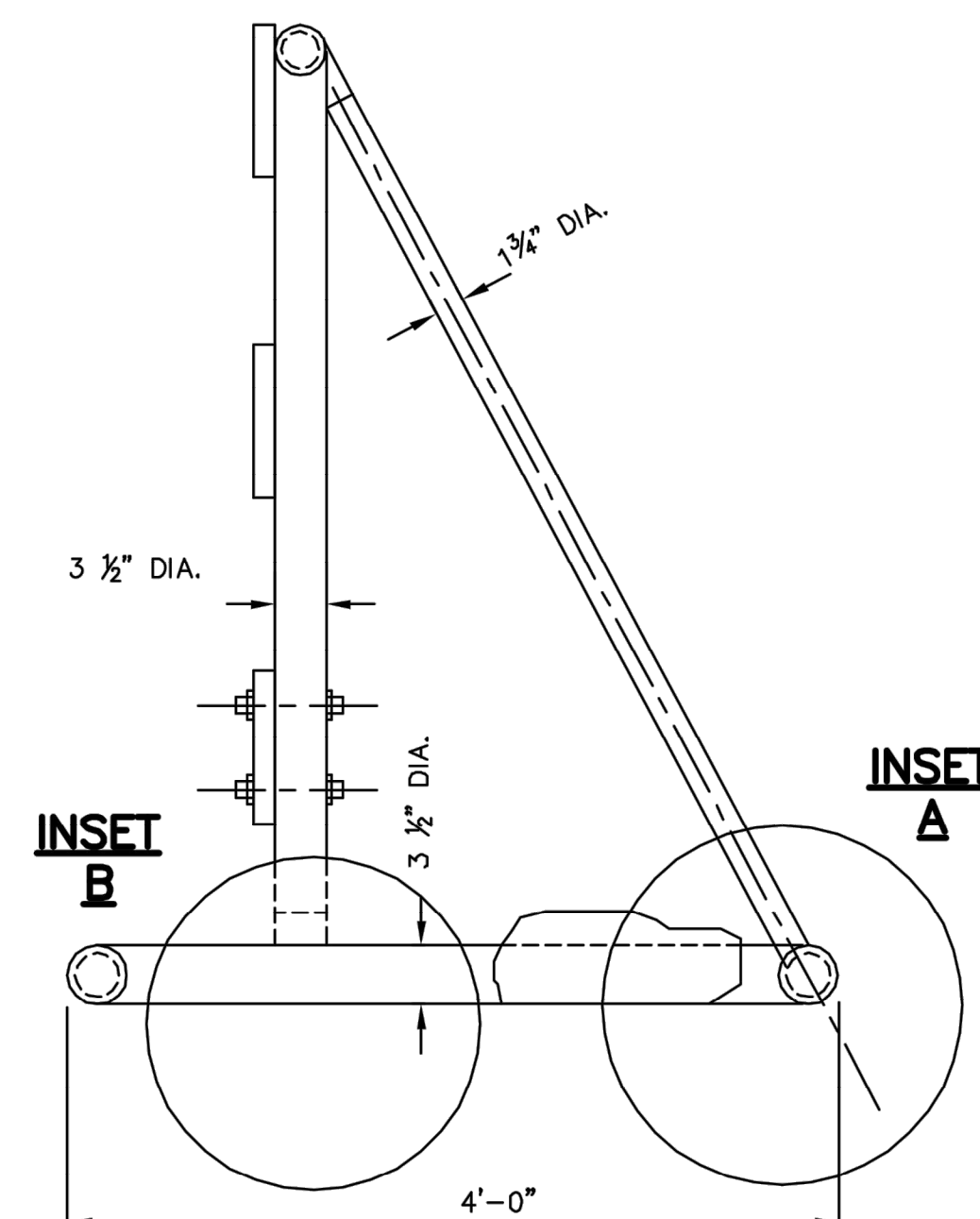
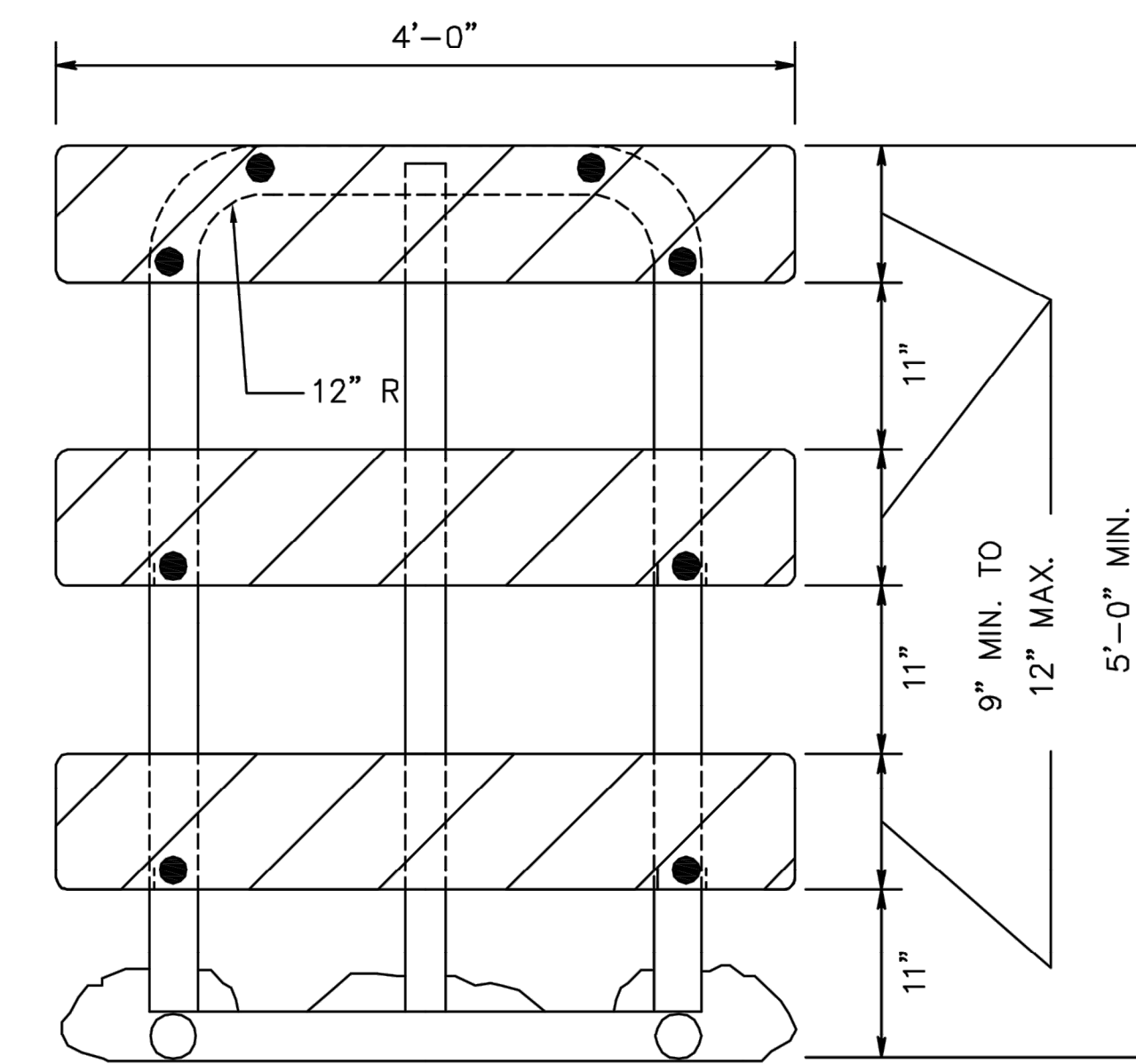

INSET B

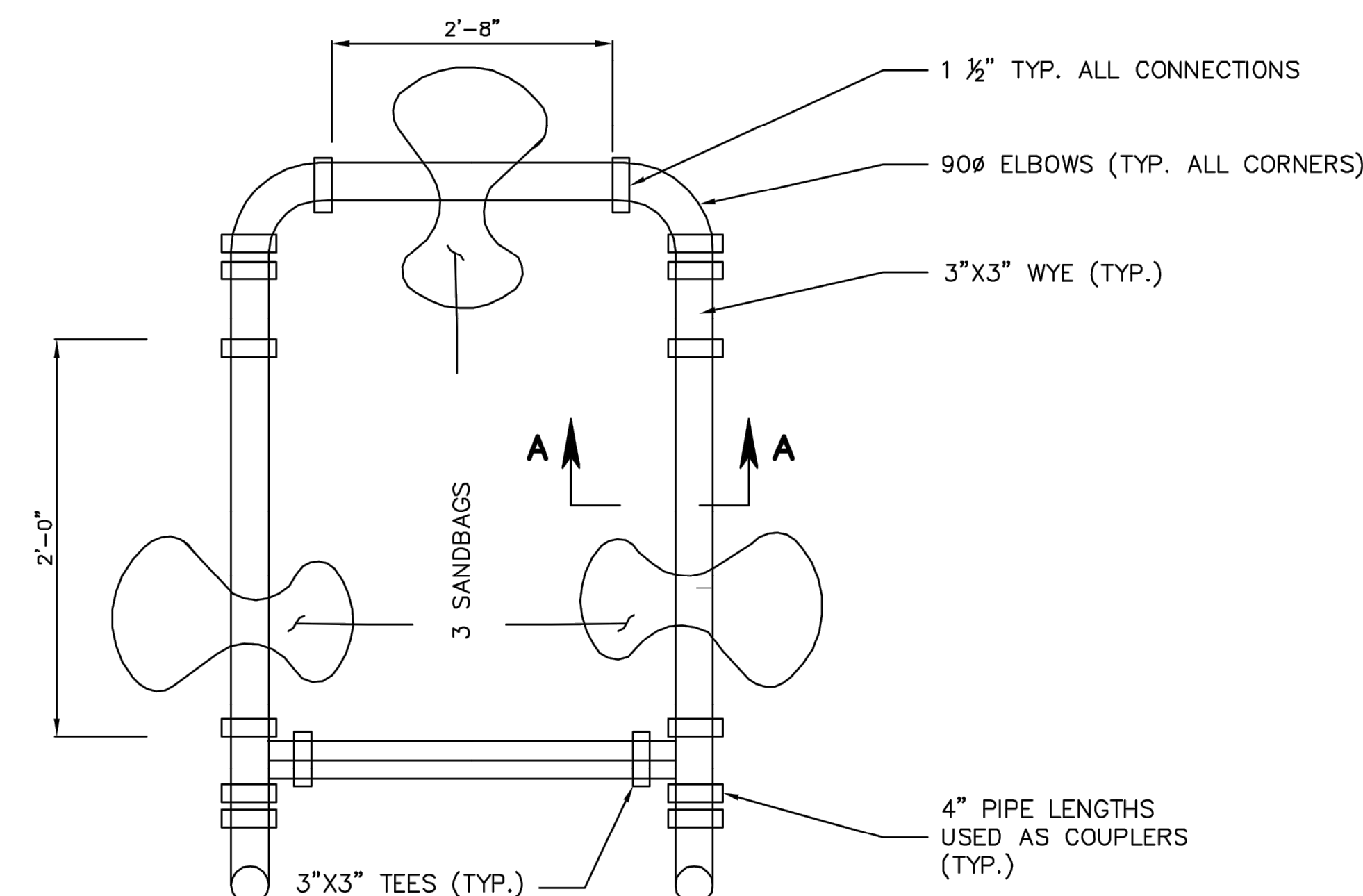

TOP VIEW OF BASE

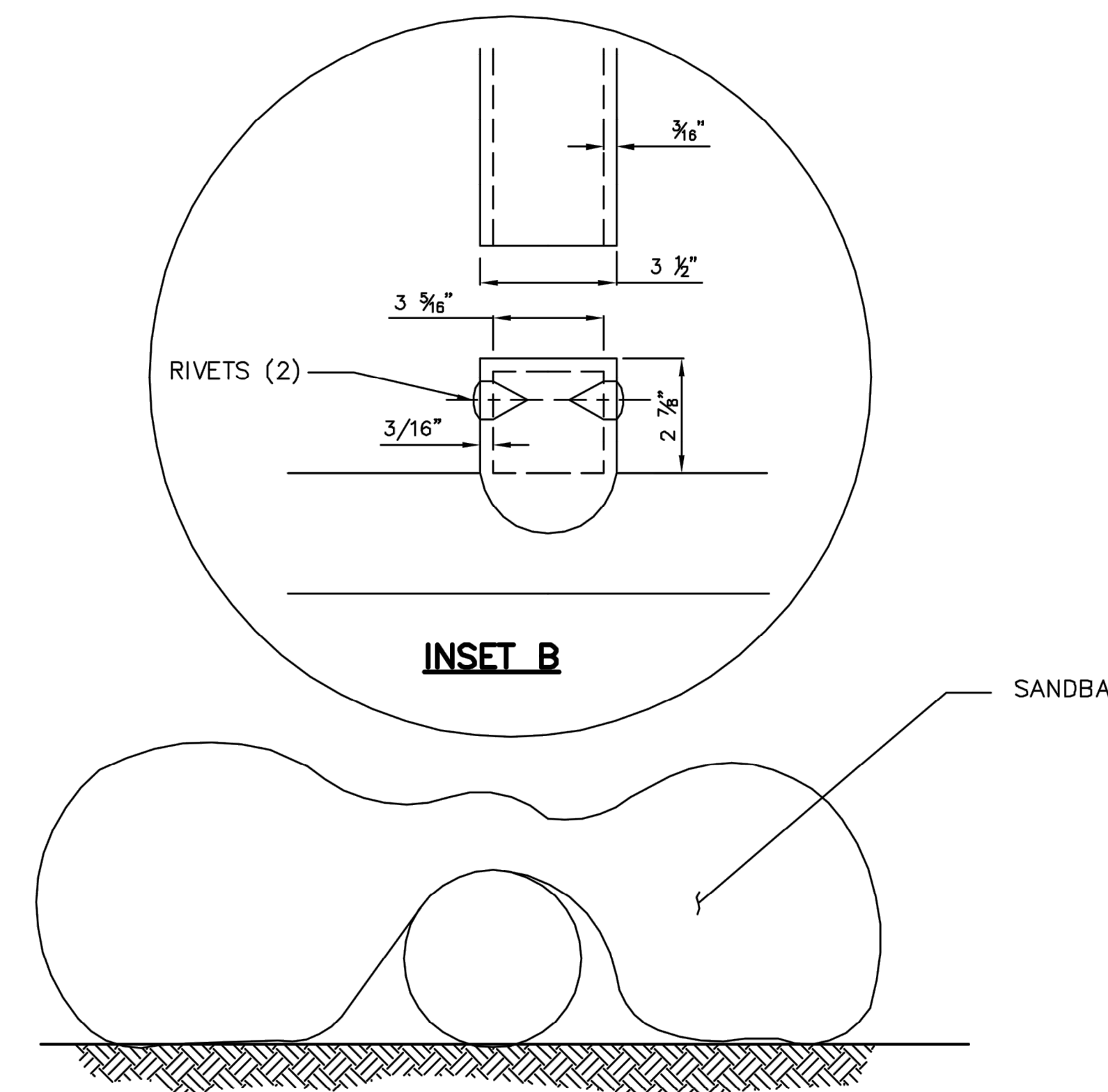

SECTION A-A

THE BASE AND UPRIGHT SHALL BE 3 1/2" DIA. ROTATIONALLY MOLDED POLYETHYLENE PLASTIC CONFORMING TO ASTM D 1248-II A3-A4. THE BRACE SHALL BE 1 3/4" DIA. EXTRUDED POLYETHYLENE PLASTIC CONFORMING TO ASTM D 1248-III A4. POLYETHYLENE PLASTIC SHALL BE WHITE AND SHALL BE ULTRAVIOLET LIGHT STABILIZED ASTM D746.

TYPE III PE

REVISION	BY	DATE
UNION COUNTY, DIVISION OF ENGINEERING		
CONSTRUCTION DETAILS		
TRAFFIC CONTROL DEVICES		
COUNTY OF UNION 2325 SOUTH AVENUE SCOTCH PLAINS, NJ 07076		SHEET NO. 19 OF 31

THE LOUIS BERGER GROUP - Feb. 10, 2014 - 12:43pm - CAD FILE: L:\TRANS\CP-2011\CCC 1263 Elizabeth Signs\CAD\DWGS\08-Construction Details\016.dwg

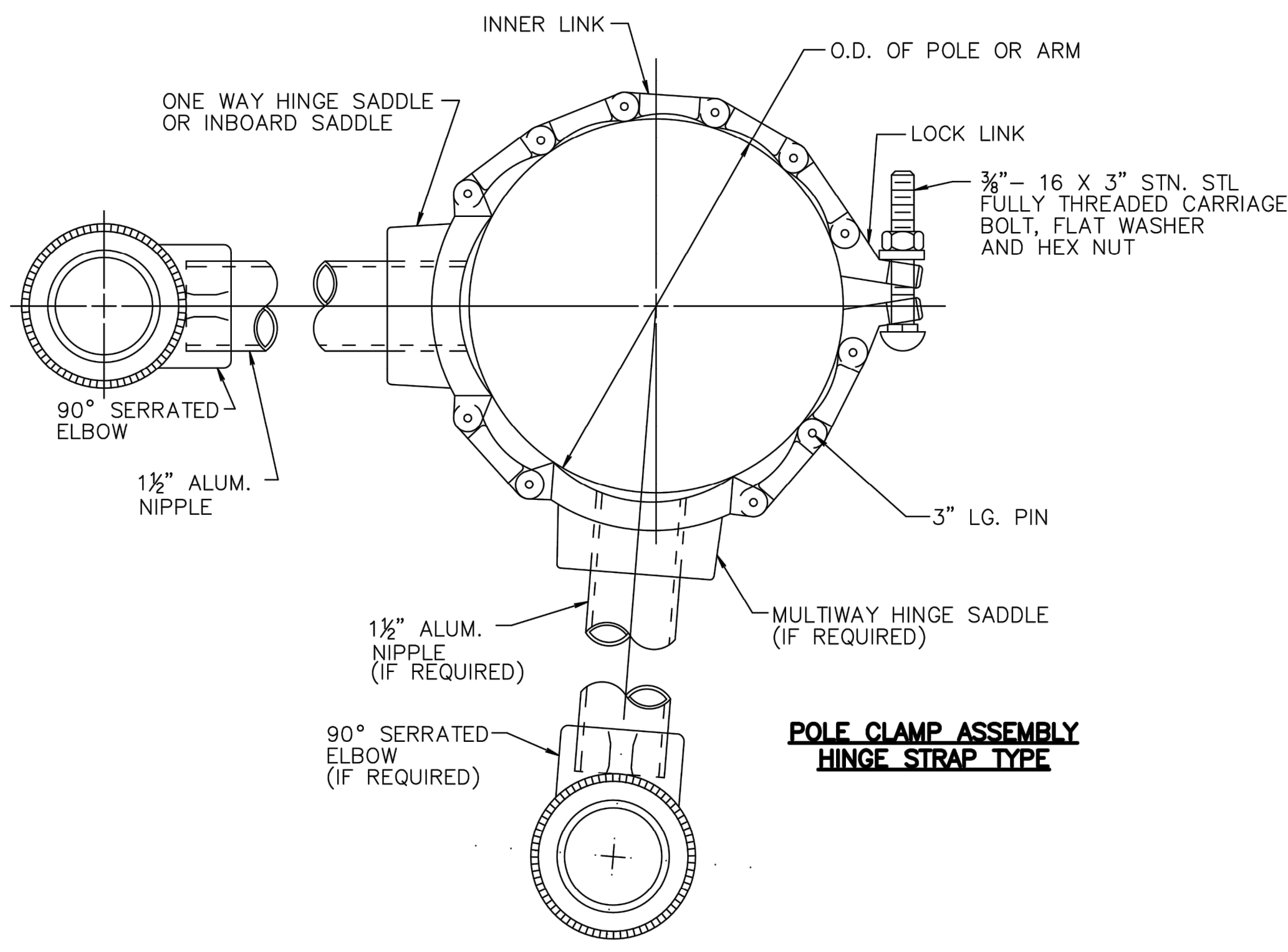

**POLE CLAMP ASSEMBLY
HINGE STRAP TYPE**

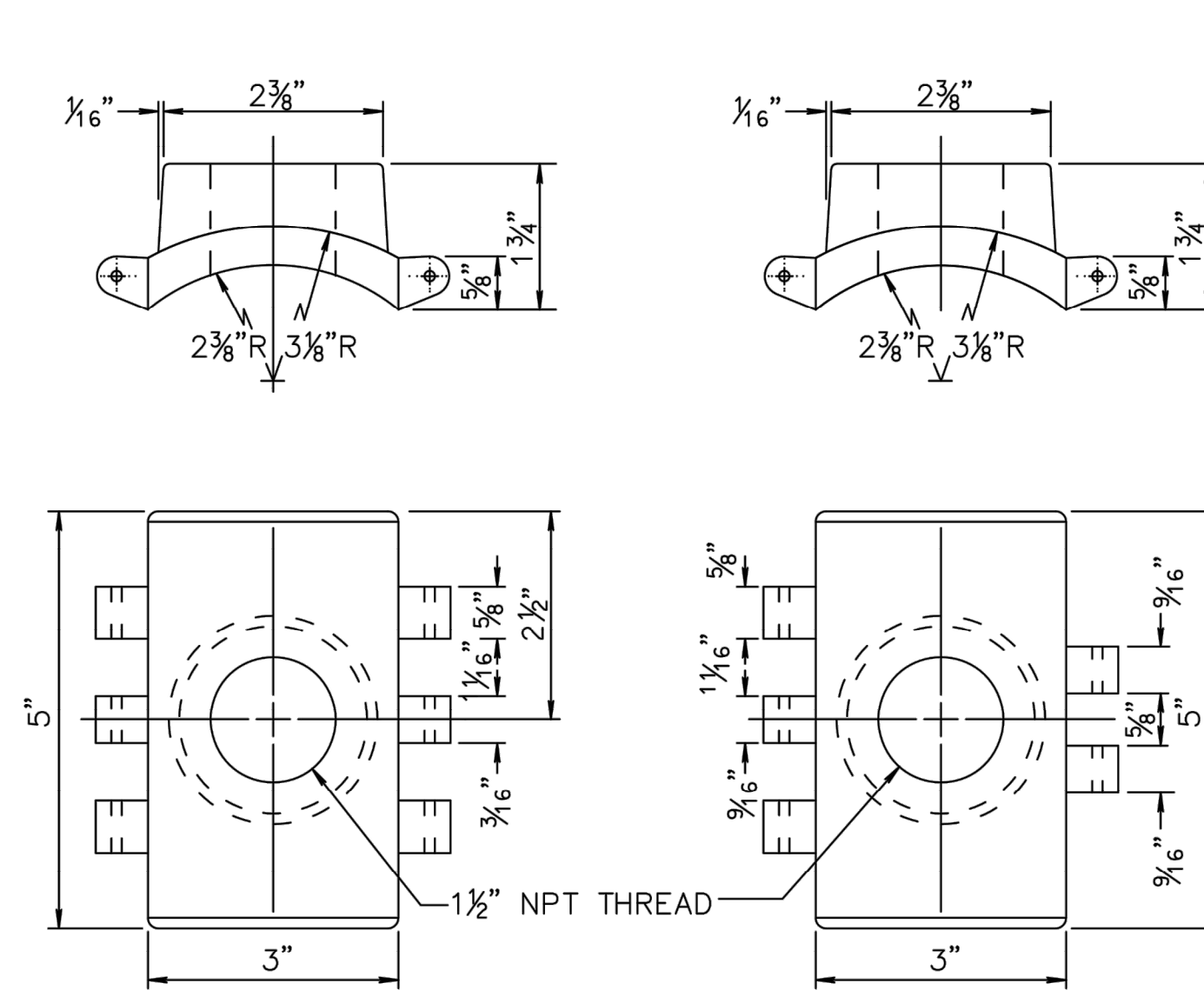

ONE-WAY HINGE SADDLE
MTL: ALUM. CASTING

MULTI-WAY HINGE SADDLE
MTL: ALUM. CASTING

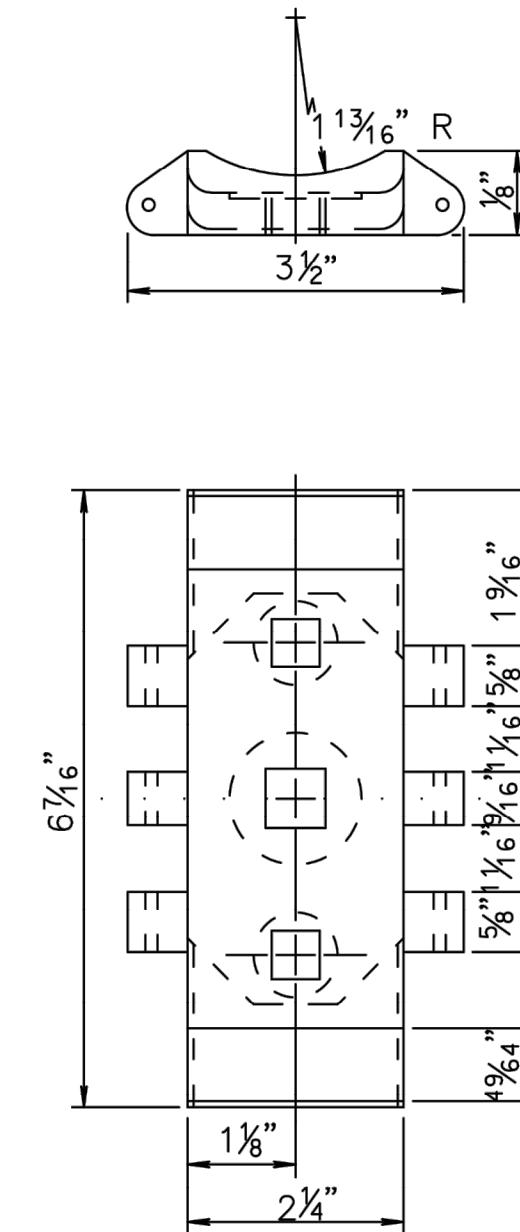

INBOARD SADDLE
MTL: ALUM. CASTING

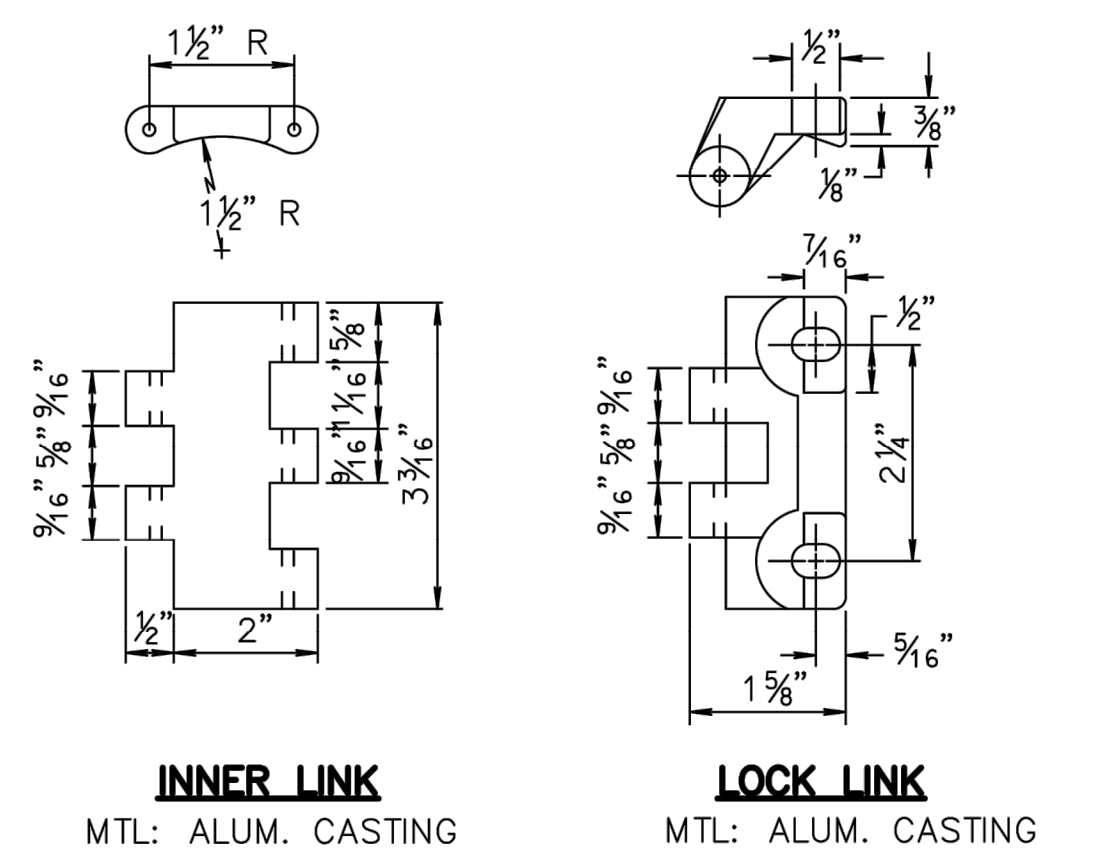

INNER LINK
MTL: ALUM. CASTING

LOCK LINK
MTL: ALUM. CASTING

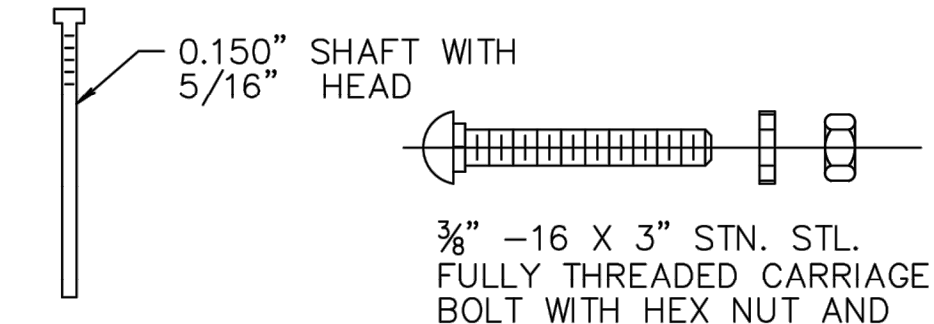

3\"/>

NOTE:
ALL HINGE STRAPS INNER LINK AND LOCK LINK PARTS SHALL BE TUMBLED FOR 18 HOURS MINIMUM USING 3/4\"/>

HINGE STRAP LIST OF MATERIALS		
DESCRIPTION	MATERIAL	NO. REQ'D
HINGE SADDLE	B26-82 CAST ALUM.	2
INNER LINK	B26-82 CAST ALUM.	23*(32)
LOCK LINK	B26-82 CAST ALUM.	4
STD. 1 1/2\"/>		

*() NUMBER REQUIRED WHEN INSTALLED ON "K" POLE

PEDESTRIAN CLAMP LIST OF MATERIALS		
DESCRIPTION	MATERIAL	NO. REQ'D
PLAIN CLAMP	ALUM. ALLOY 443.0	2
OUTLET CLAMP	ALUM. ALLOY 443.0	2
BOLT, HEX HD. 1/2\"/>		

NOTE:
HARDWARE SHALL BE TIGHTENED AS PER TORQUE RATING AS RECOMMENDED BY THE MANUFACTURER.

PEDESTRIAN CLAMP DIMENSIONS			
A	B	C	BOLT LGTH.
6"-8"	1.25"	2.5"	6.0"
8"-10"	1.25"	2.5"	7.5"
10"-12"	1.50"	2.875"	9.0"

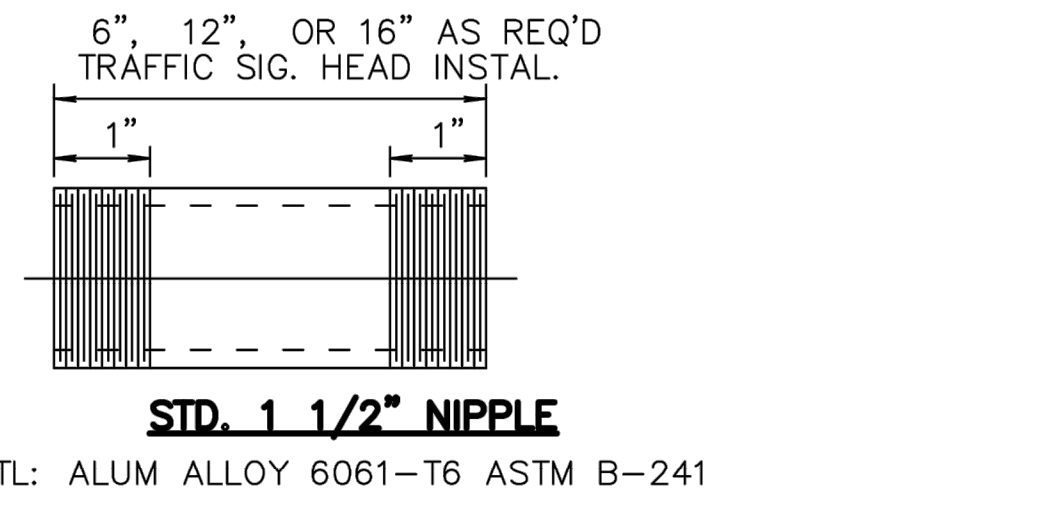

STD. 1 1/2\"/>

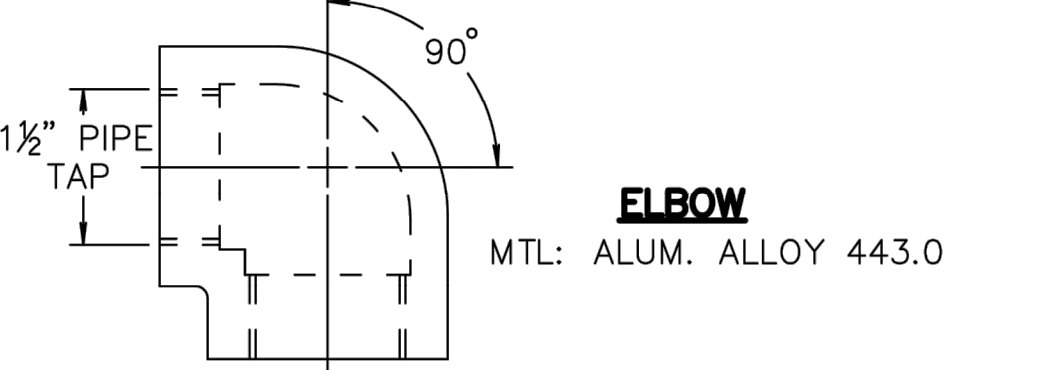

ELBOW
MTL: ALUM. ALLOY 443.0

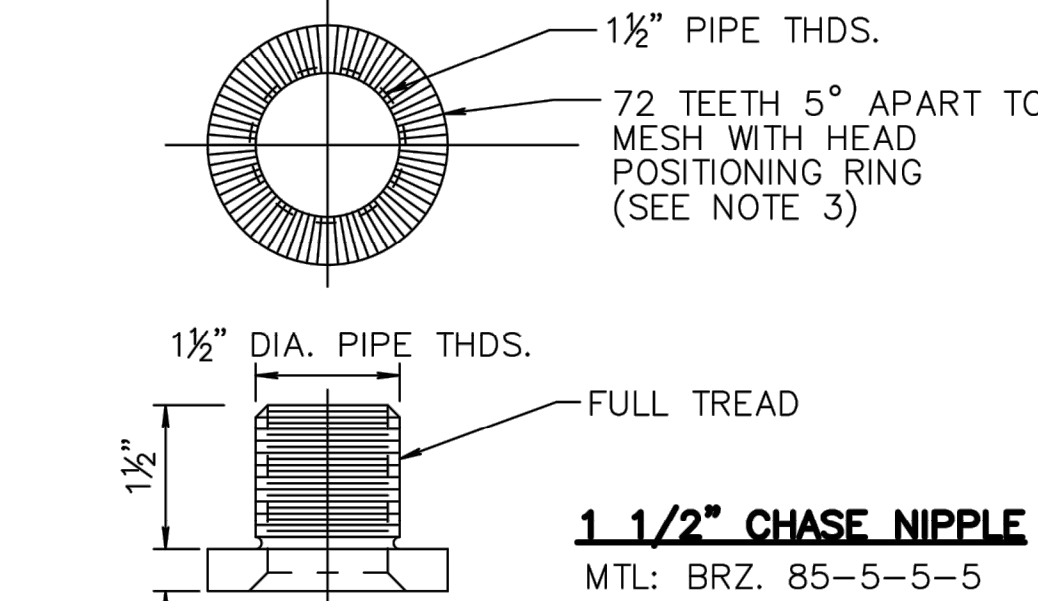

1 1/2\"/>

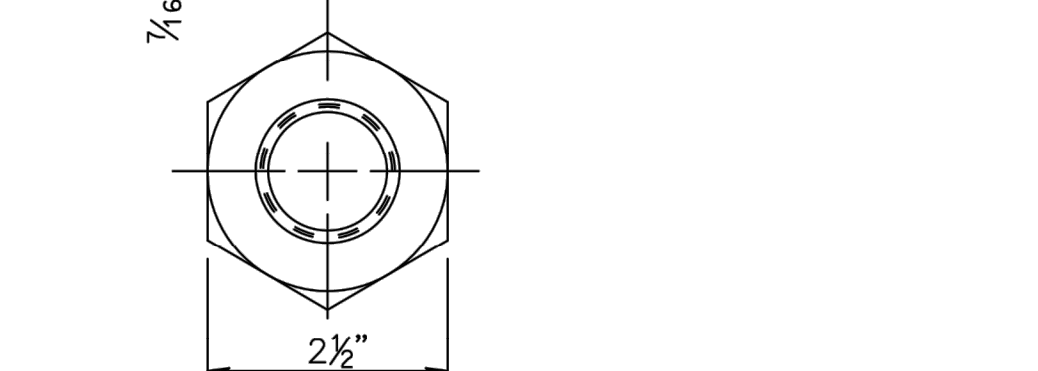

NIPPLE, ELBOW AND/OR CHASE NIPPLE TO BE USED WITH HINGE STRAP OR PEDESTRIAN CLAMP AS REQUIRED.

NOTES:

- PEDESTRIAN CLAMP TYPE CAST ALUMINUM, CLAMP SHOWN MUST MEET THE FOLLOWING TESTS: 6" DIA. CLAMP TEST.
COMPLETE CLAMP SHALL BE SET ON 6" DIA. POLE. COMPLETE CLAMP WITH 6.5" DIA. SET SHALL BE SET ON 8" DIA. POLE. COMPLETE CLAMP AFTER BEING SET FROM 8" DIA. POLE SHALL BE RESET ON 6" DIA. POLE. CLAMPS SHALL NOT SHOW ANY FRACTURES AFTER THE SETTING AND RESETTING PROCEDURE. THIS TEST TO BE CONDUCTED IN THE PRESENCE OF A REPRESENTATIVE OF THE NEW JERSEY DEPARTMENT OF TRANSPORTATION. MANUFACTURER SHALL ALSO SUBMIT DRAWING OF CLAMP TO BE FURNISHED FOR APPROVAL OF THE NEW JERSEY DEPARTMENT OF TRANSPORTATION.
- CAST ALUM. CLAMPS OF LARGER DIA. WILL BE TESTED IN A SIMILAR MANNER.
- PROVIDE SLOTS OR SERRATIONS IN FACE OF ELBOW OR SLOTS & SERRATED POSITIONING RING. SLOTS TO BE 5/32" DP X 3/16" W. SERRATIONS TO MATCH HOUSING AND ALLOW 5" ADJUSTMENT.
- UNITS SHALL BE MANUFACTURED IN ACCORDANCE WITH AASHTO STANDARD SPECIFICATIONS FOR STRUCTURAL SUPPORTS FOR HIGHWAY SIGNS, LUMINAIRES AND TRAFFIC SIGNALS.
- INSTALL 1 1/2" I.D. RUBBER GROMMET IN TRAFFIC SIGNAL STANDARD.
- ALL STN. STL. BOLTS PER ASTM A193 GRADE B8 OR ASTM F593 ALLOY 304.
- ALL ALUM. SAND CASTINGS SHALL BE ASTM B26 ALLOY.
- ALL ALUM. NIPPLES SHALL BE 6061-T6, ASTM B-241 ALLOY; MIL. SPEC. QQA 200/80F.
- HINGE STRAP IS ADAPTABLE TO ANY POLE DIA. BY ADDING OR REMOVING INNER LINKS.
- HINGE STRAP CAN BE INSTALLED ON ROUND, SQUARE, OCTAGONAL OR ANY SHAPE POLE DESIRED.
- ALL TOLERANCES OF CASTINGS SHALL BE ±1/32".
- WHEN PEDESTRIAN CLAMP IS INSTALLED ON A 6" DIA. POLE, CLAMP SHALL BE DESIGNED TO PROVIDE A MINIMUM GAP OF 1/4".

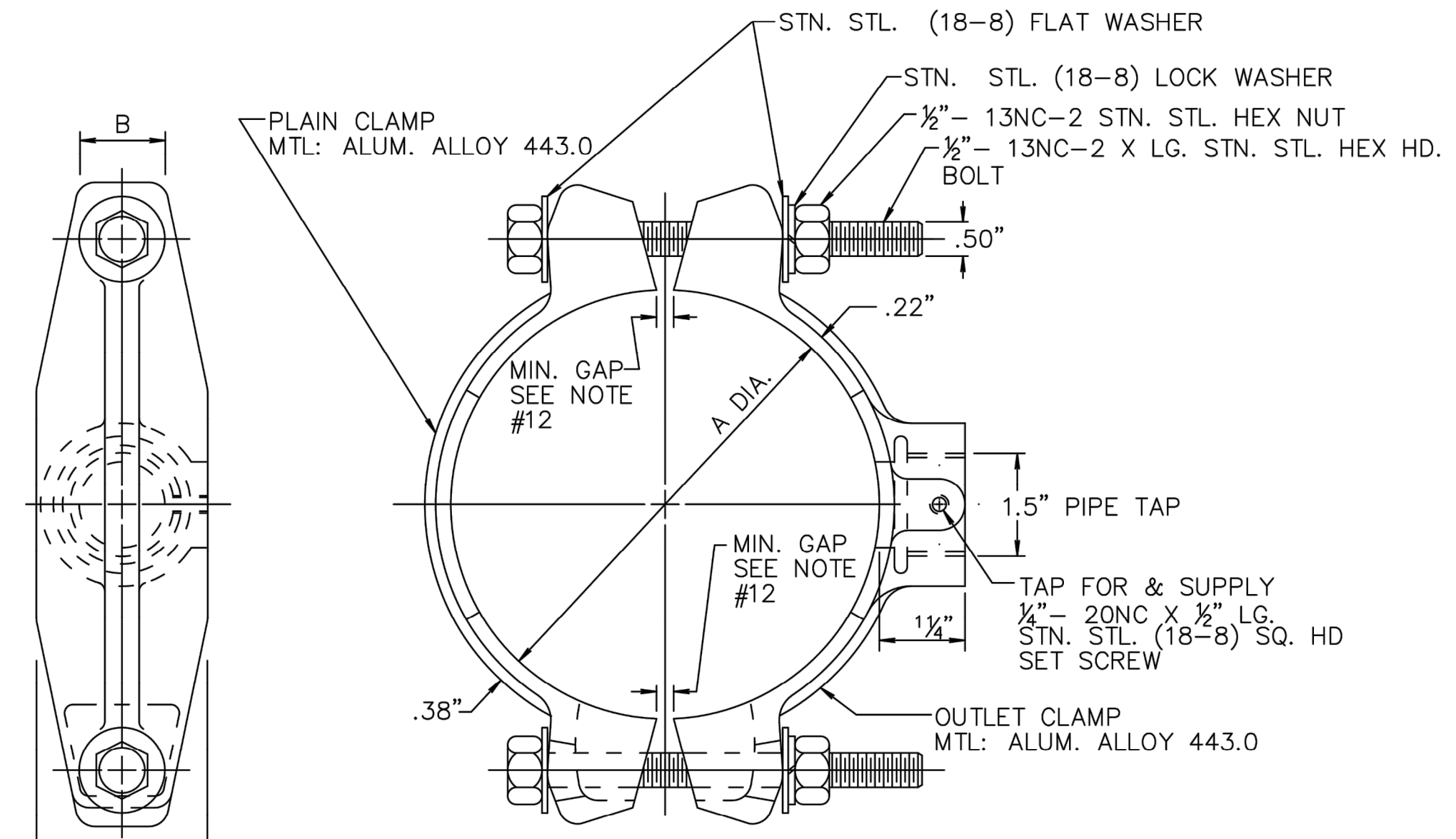

**POLE CLAMP ASSEMBLY
PEDESTRIAN CLAMP TYPE**

THE LOUIS BERGER GROUP - Feb. 10, 2014 - 12:15pm - CAUD FILE: L:\TRANS\CP-2011\CCC 1263 Electrical Signal\CAUD\UNCS\08 - Construction Details\04.dwg

REVISION	BY	C/K/D	DATE
UNION COUNTY, DIVISION OF ENGINEERING			
ELECTRICAL DETAILS			
SIGNAL ASSEMBLY DETAILS			
COUNTY OF UNION 2325 SOUTH AVENUE SCOTCH PLAINS, NJ 07076			SHEET NO. 22 OF 31

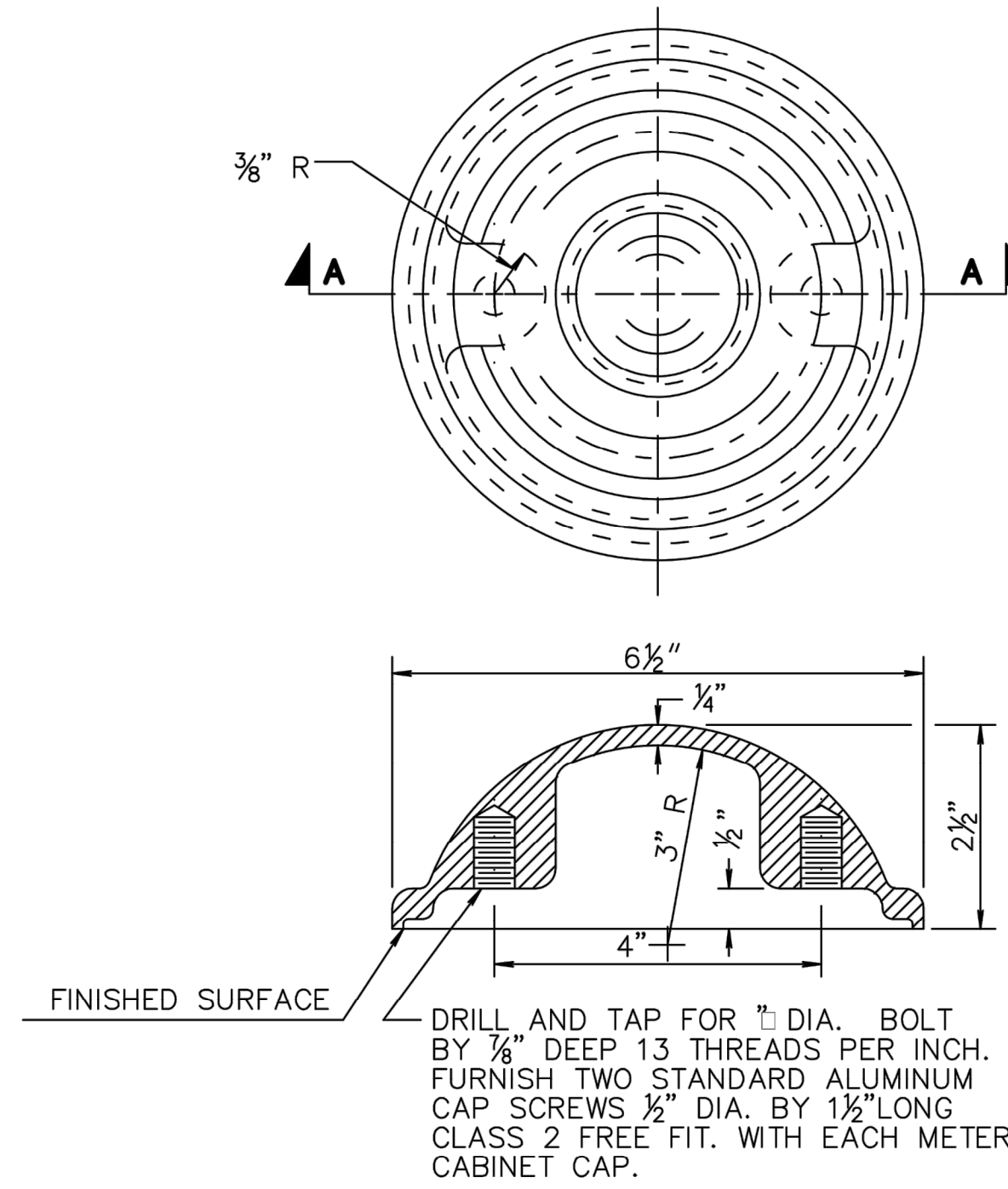
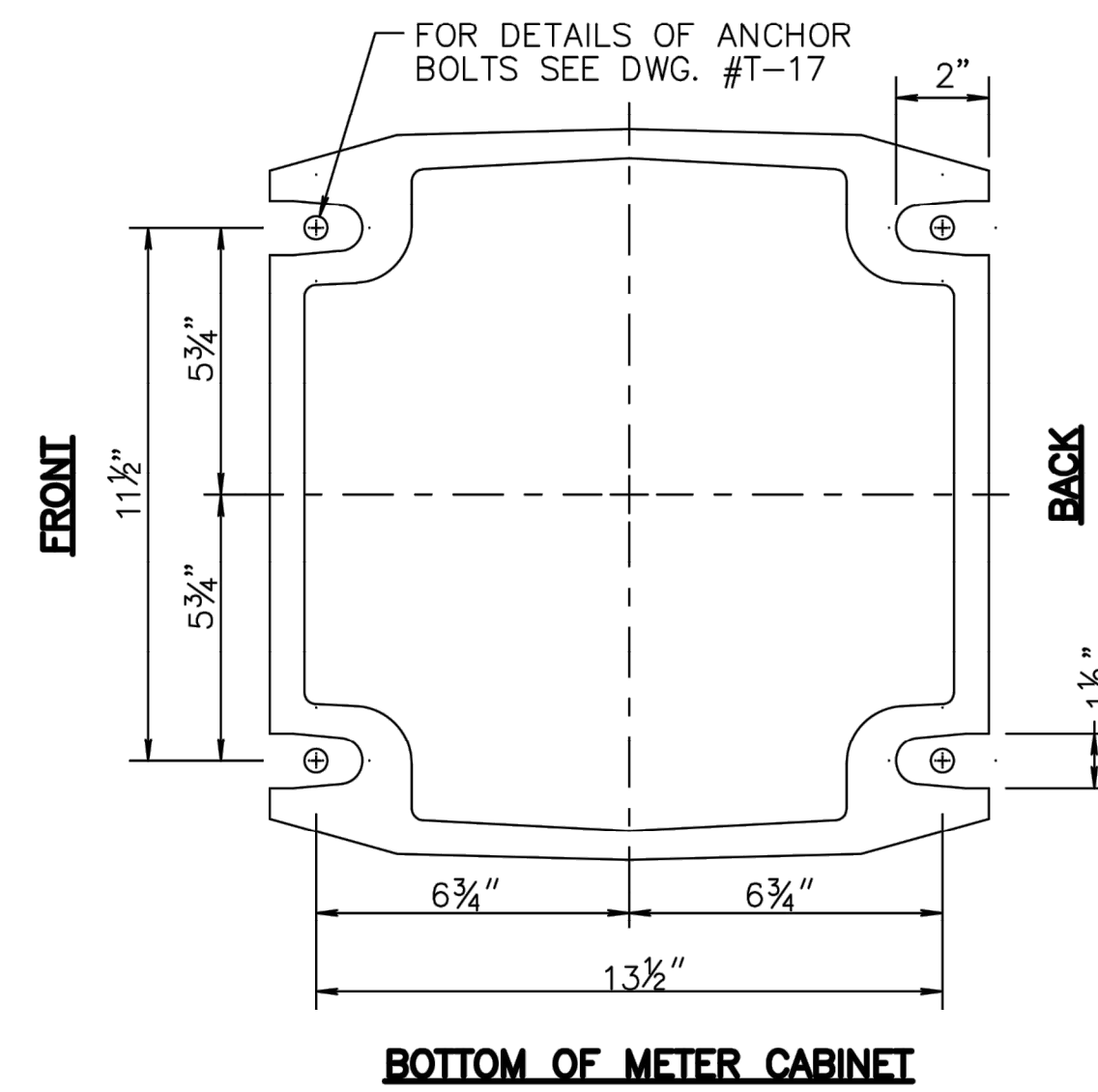
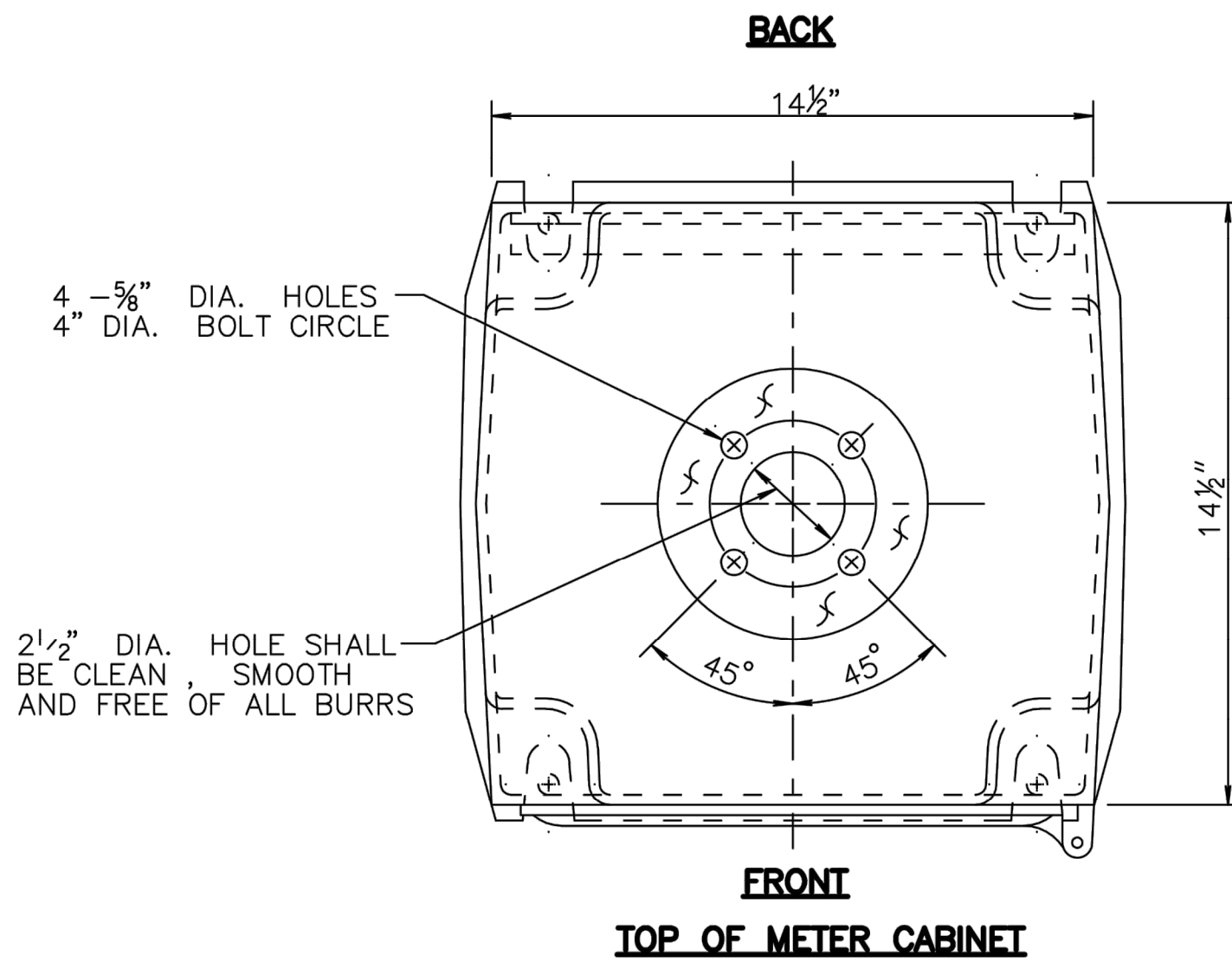

PROVIDE APPROVED WATERTIGHT COVER (SEE DETAIL OF METER CABINET CAP.)

DOOR SHALL BE PROVIDED WITH CONTINUOUS NEOPRENE GASKET SECURED IN DOOR GROOVE TO INSURE DUST TIGHT AND WEATHERPROOF PROTECTION.

CORBIN LOCK NO. 0357 S.G. NO SUBSTITUTE

METER SOCKET AND METER (IF REQUIRED, SEE NOTE 6)

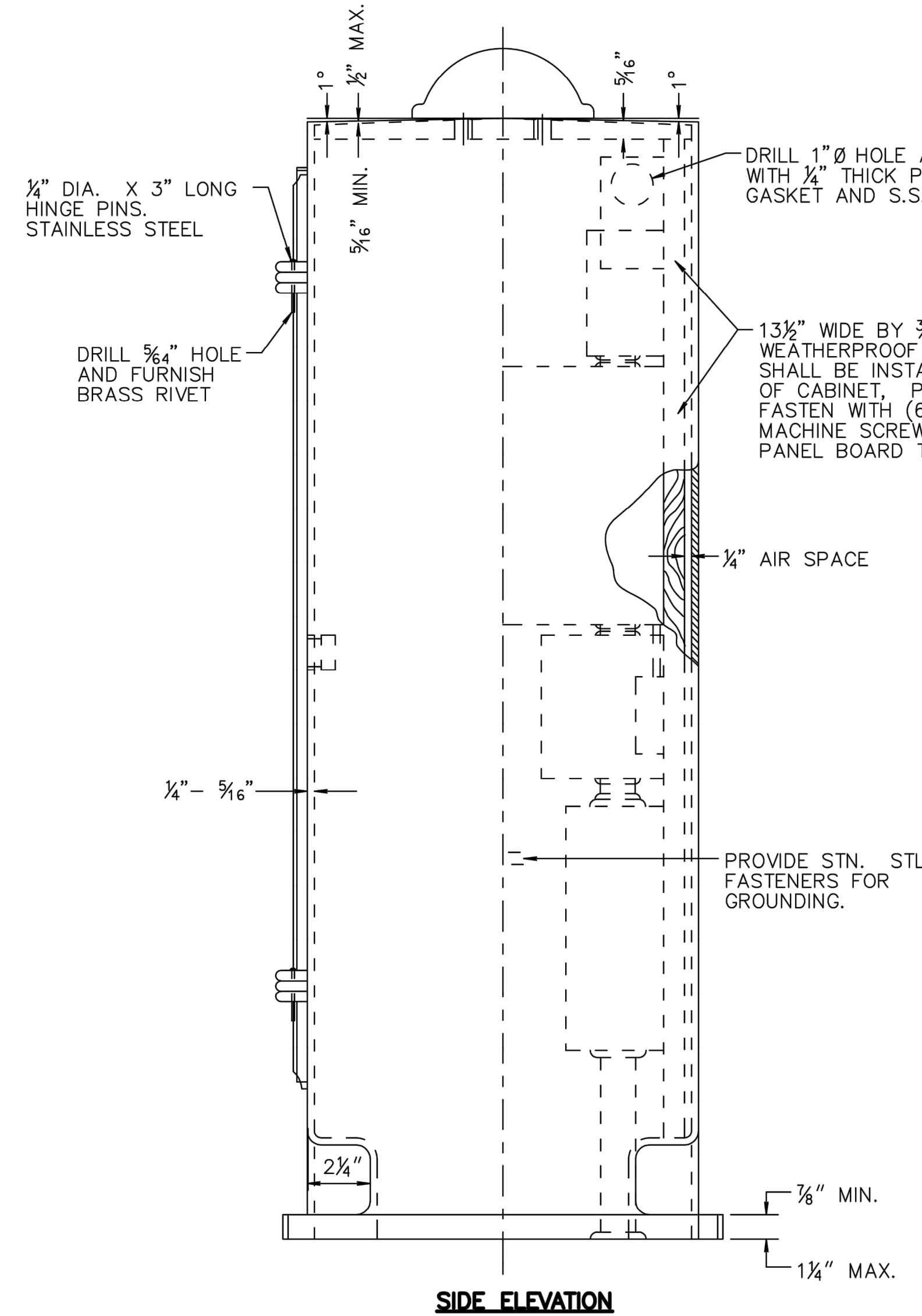
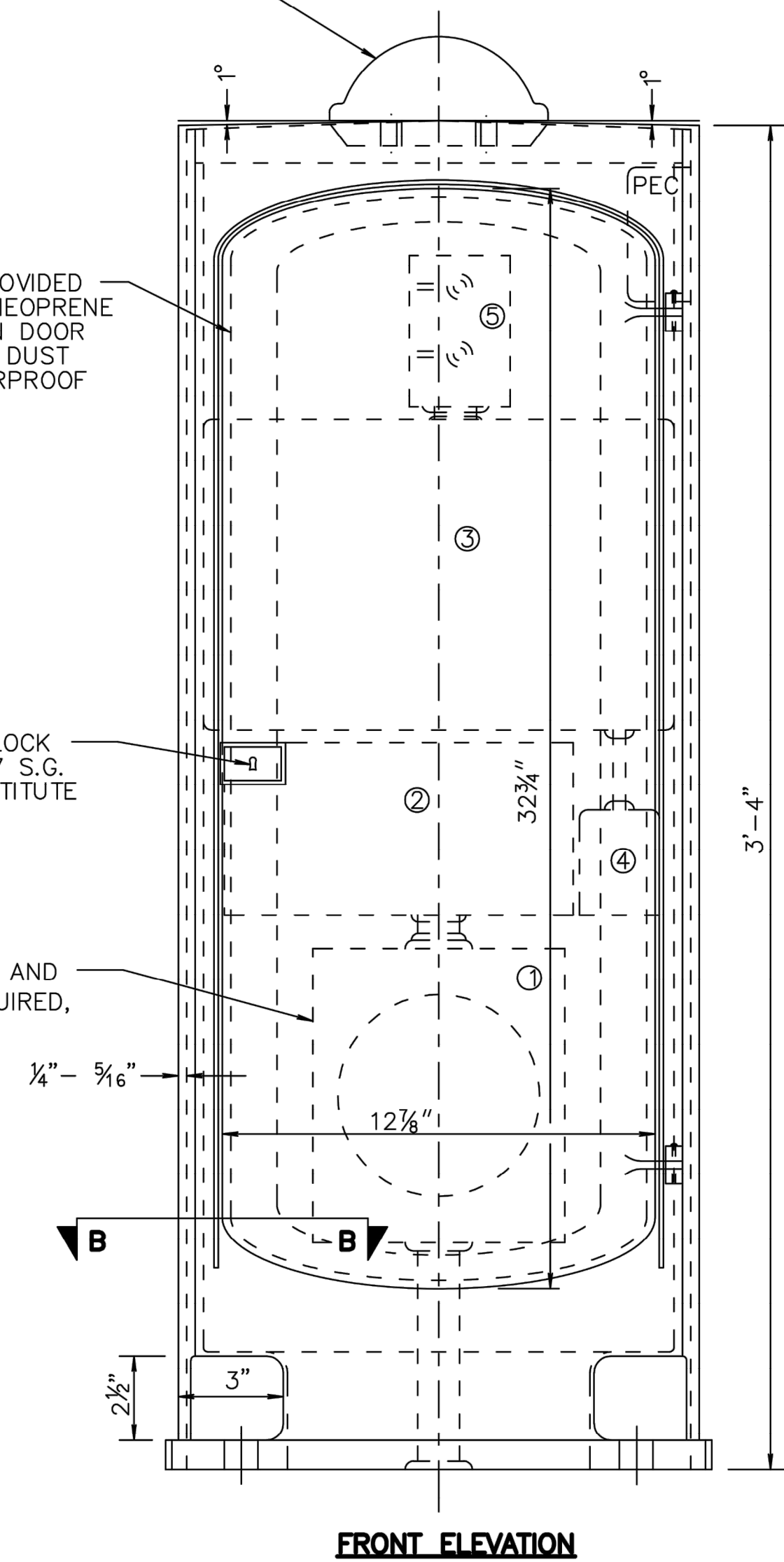

METER CABINET DETAIL

— ALUMINUM ALLOY, COMMERCIAL DESIGNATION 356 A.S.T.M. DESIGNATION B26-56T, ALLOY SG 70A.
 — THE CABINET SHALL BE FREE OF BURRS, SHARP EDGES, DENTS, PINHOLES, AND PARTING LINES AND SHALL HAVE A UNIFORM #30 GRIT FINISH.
 — FOR ALTERNATE FABRICATED METER CABINET SEE DWG. T-35

METER CABINET TYPE "T"

METER CABINET TYPE "TL" - SEE NOTE #8

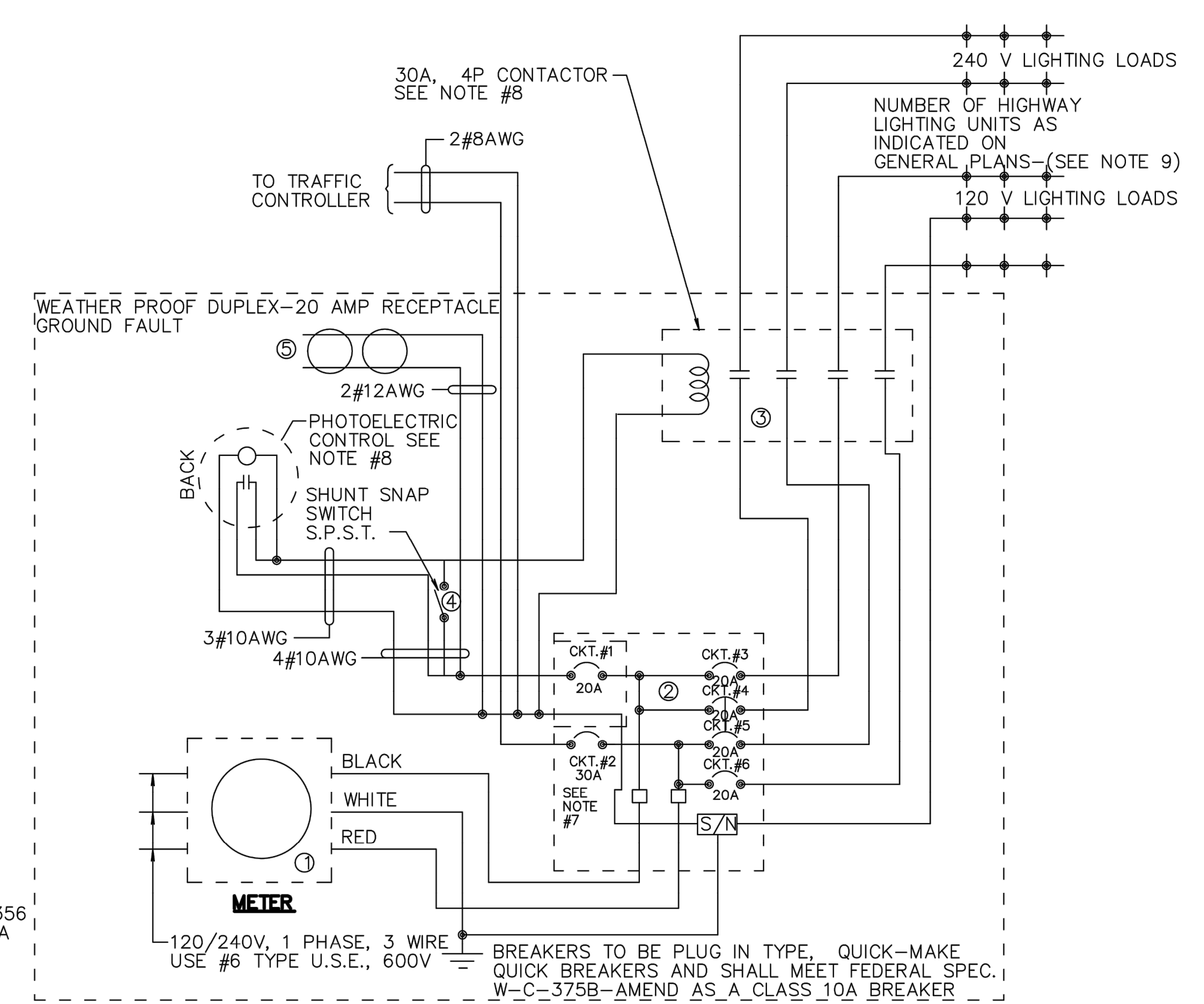

SCHEMATIC WIRING DIAGRAM: 120/240 VOLT

LEGEND

- ① METER SOCKET—INSTALLED BY CONTRACTOR—PROVIDED BY UTILITY COMPANY ON REQUEST. (IN JCP&L CO. AREA METER SOCKET IS TO BE INSTALLED AND FURNISHED BY CONTRACTOR)
- ② 4/8 CIRCUIT LOAD CENTER WITH ENCLOSURE COMPLETE WITH 1-30A & 5-20A CIRCUIT BREAKERS.
- ③ MAGNETIC CONTACTOR, 30 AMP, 120 VOLT COIL NEMA 1 ENCLOSURE.
- ④ PHOTOELECTRIC CONTROL UNIT 15 AMP. SHUNT SWITCH IN 2" X 4" HANDY BOX OR EQUIVALENT.
- ⑤ WEATHERPROOF, 20A DUPLEX RECEPTICAL GROUND FAULT.
- ⑥ IF METER IS NOT REQUIRED, INSTALL 1" I.D. SEALTITE FLEX CONDUIT AND 1" I.D. NIPPLE FROM REDUCER COUPLING TO MAIN BREAKER PANEL.
- ⑦ A 40 AMP BREAKER SHALL BE INSTALLED WITH EIGHT PHASE CONTROLLER ASSEMBLIES.
- ⑧ FOR METER CABINET TYPE "TL", PHOTOELECTRIC CONTROL AND MAGNETIC CONTACTOR SHALL BE FURNISHED AND INSTALLED.
- ⑨ THE TOTAL NUMBER OF CIRCUIT BREAKERS SHALL NOT EXCEED SIX.

REVISION	BY	C'D	DATE
UNION COUNTY, DIVISION OF ENGINEERING			
ELECTRICAL DETAILS			
METER CABINET			
COUNTY OF UNION 2325 SOUTH AVENUE SCOTCH PLAINS, NJ 07076			SHEET NO. 23 OF 31

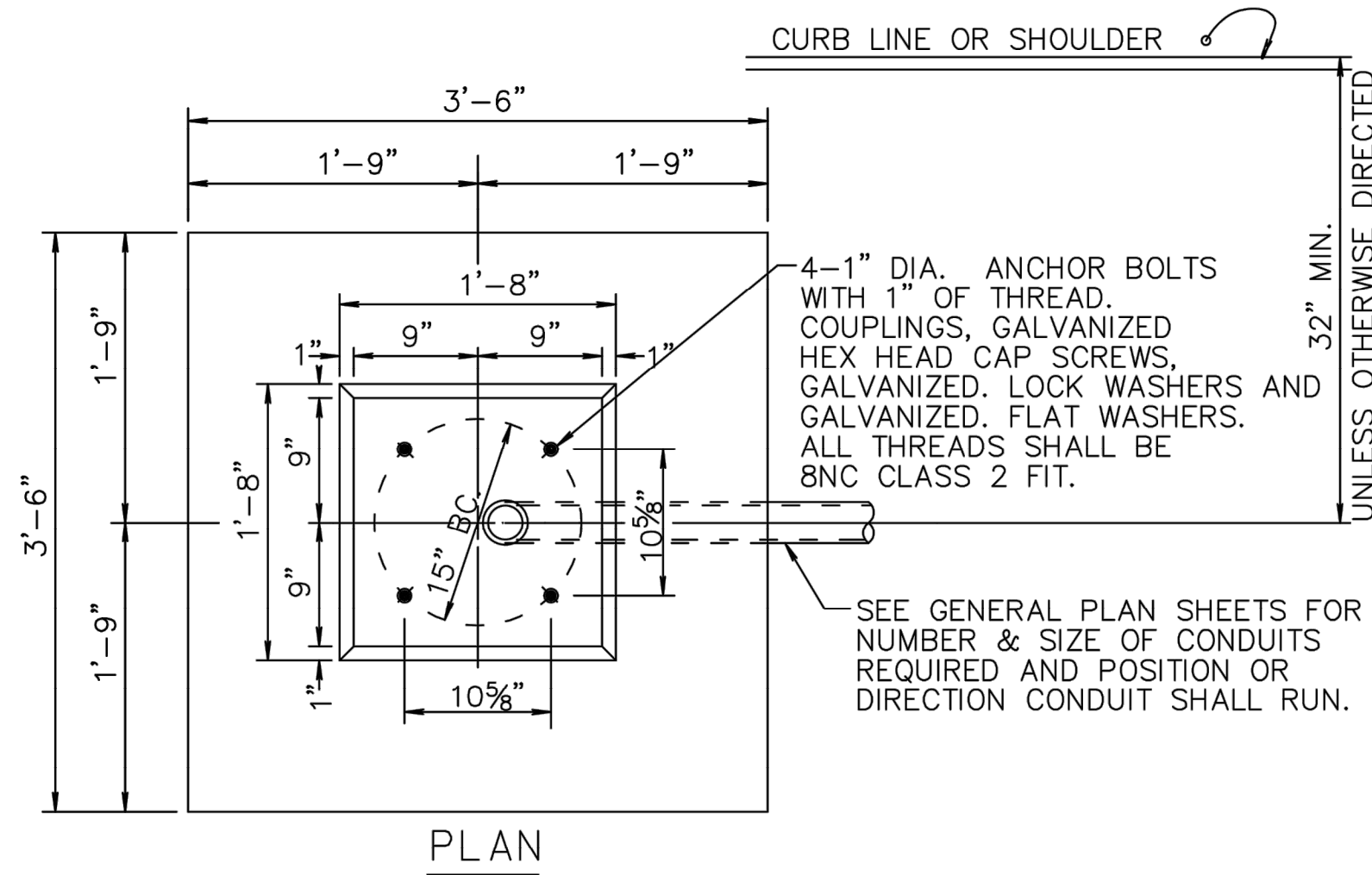

CONCRETE CLASS "C"
1.5 CU. YDS.
FOUNDATION SHALL BE POURED MONOLITHIC

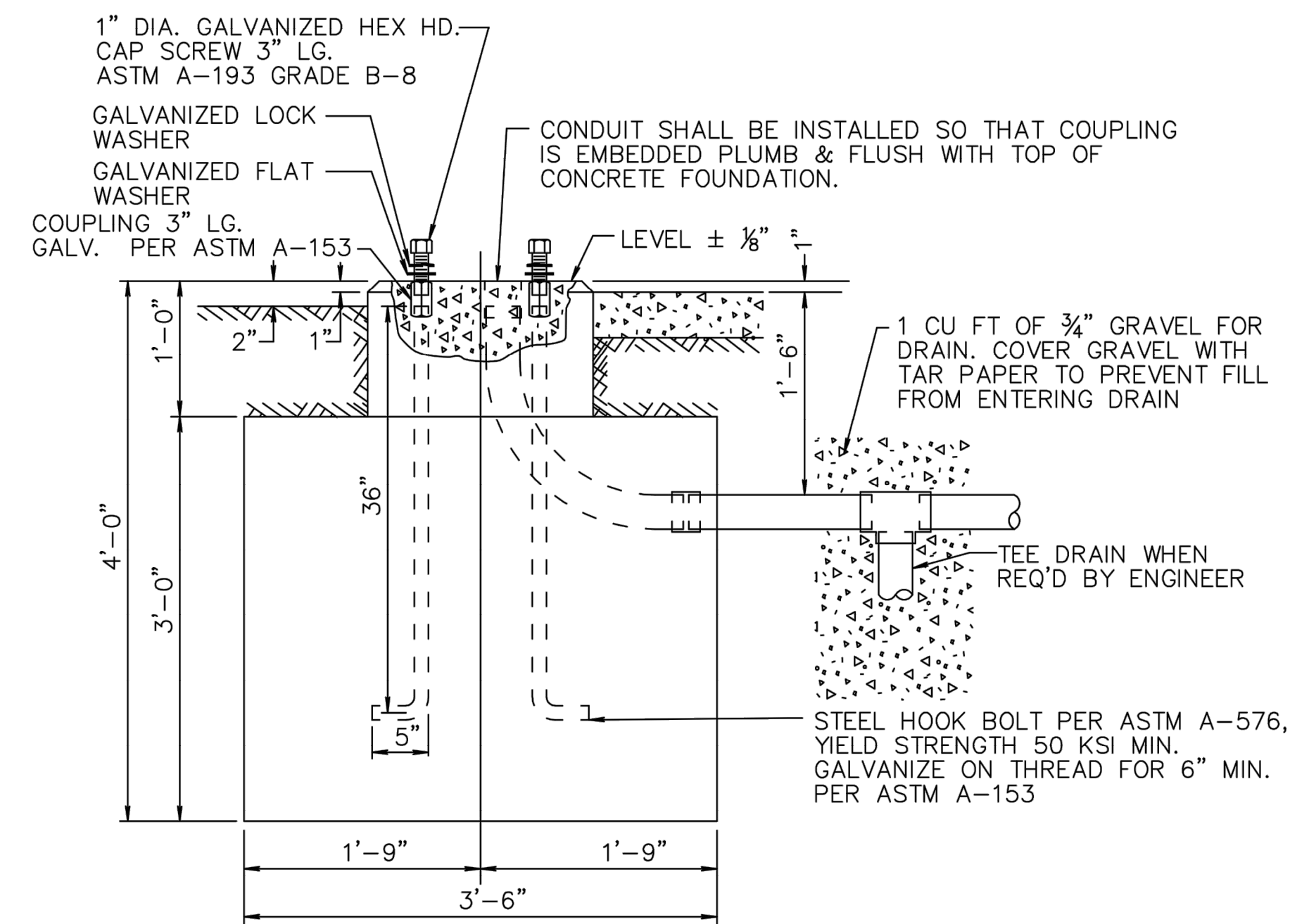

ELEVATION
STANDARD FOUNDATION TYPE "SFT"

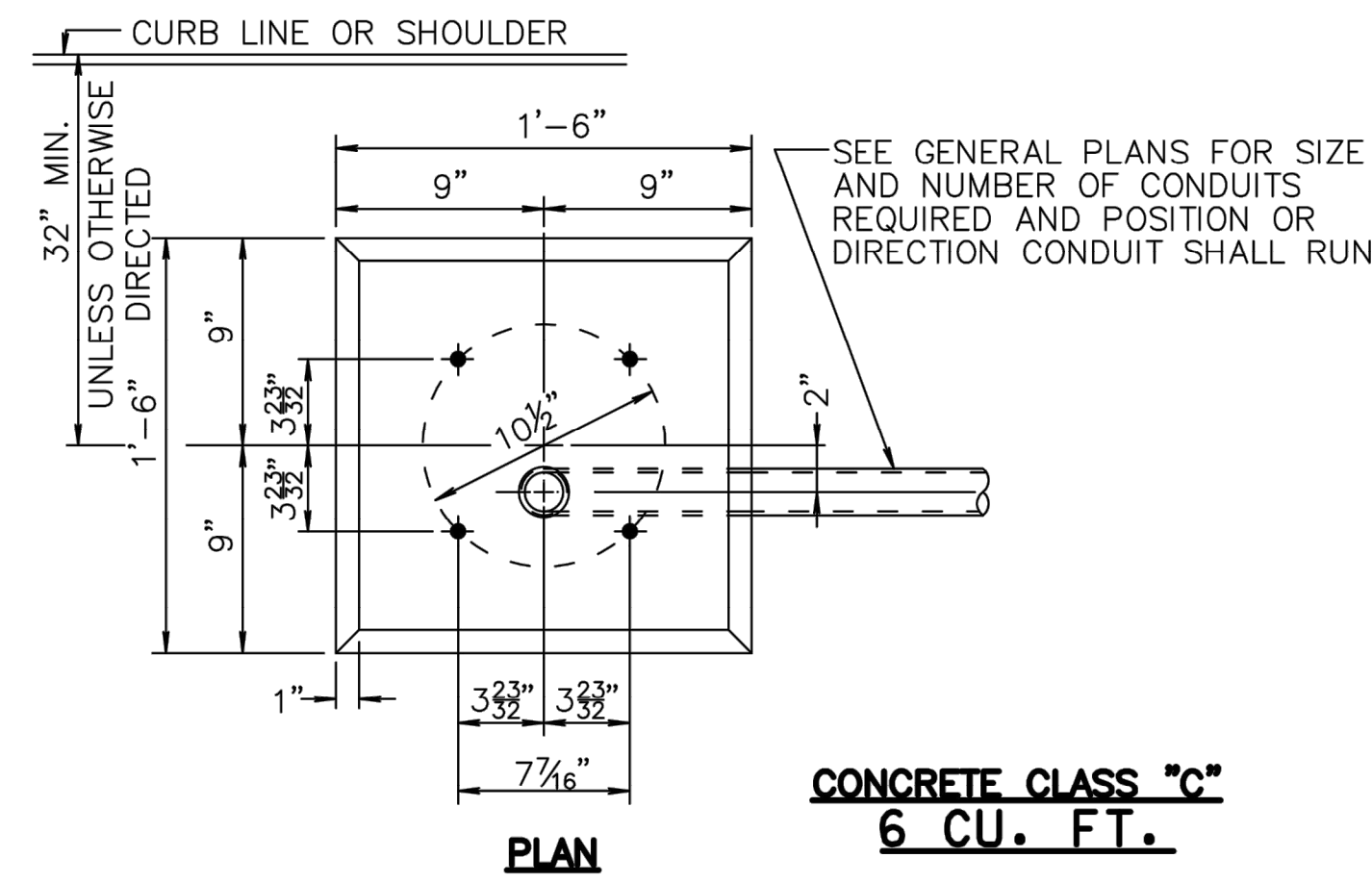

CONCRETE CLASS "C"
6 CU. FT.

4-3/4" DIA ANCHOR BOLTS WITH 1" OF THREAD. COUPLINGS, GALVANIZED HEX HEAD CAP SCREWS 1 1/2" LG. ASTM A193, GRADE B8, GALVANIZED LOCK WASHERS AND GALVANIZED FLAT WASHERS. ALL THREAD SHALL BE 3/4" -10NC CL.

CONDUIT SHALL BE INSTALLED SO THAT COUPLING IS EMBEDDED PLUMB AND FLUSH WITH TOP OF CONCRETE FOUNDATION.

GALVANIZED LOCK WASHER 1 1/8" I.D. X 1 1/2" O.D.

3" LG. GALV. COUPLING

LEVEL ± 1/8"

12" LG. HOOK BOLT WITH 1" OF THD. TOP 6" SHALL BE GALVANIZED PER ASTM A-153

INSTALL TEE DRAINS IN CONDUIT RUN WHEN REQ'D BY ENGINEER.

ELEVATION

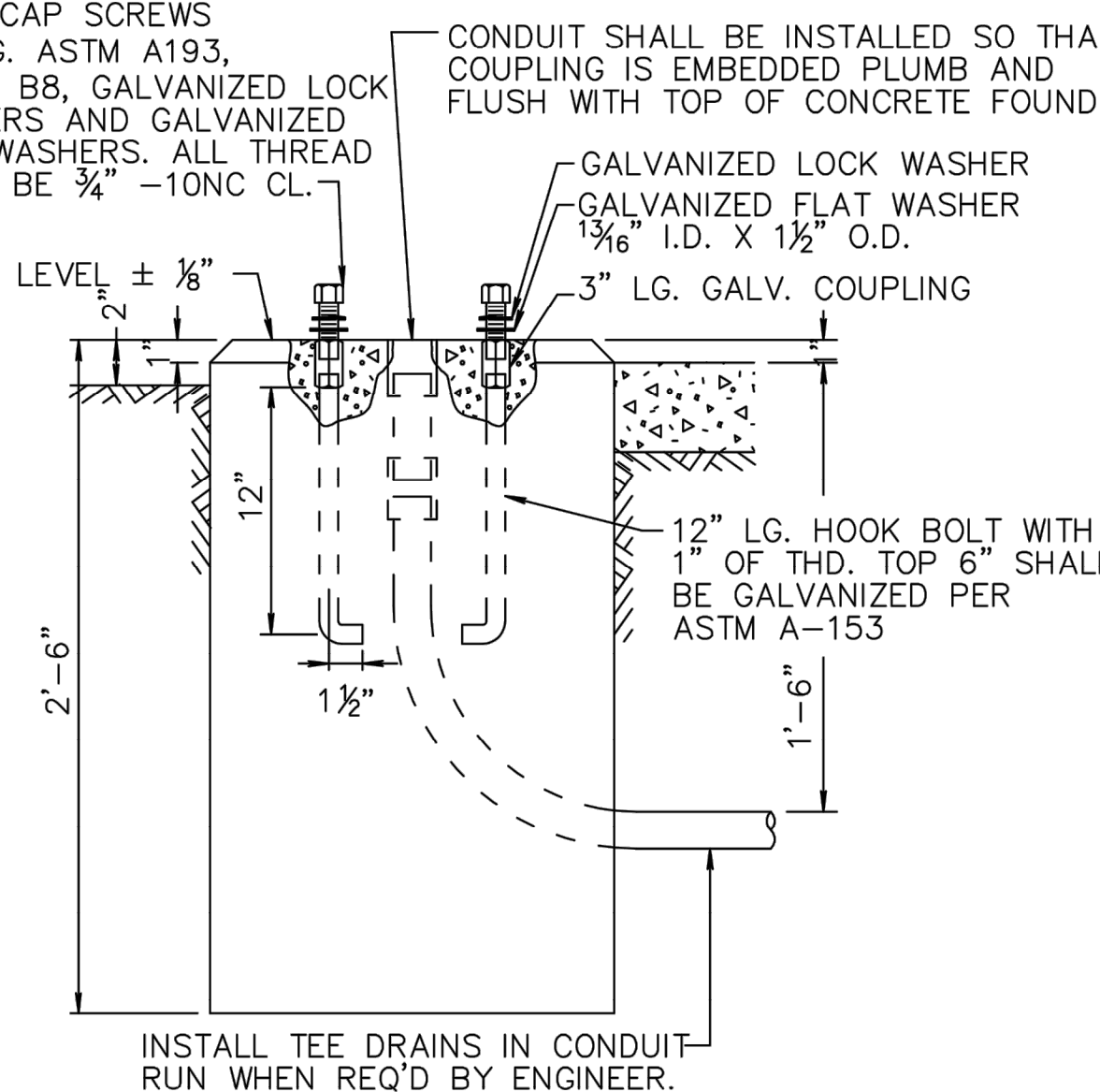

ELEVATION
PEDESTAL FOUNDATION TYPE "SPF"

GALV. PER ASTM A-153
 CONTINUOUS THREADS

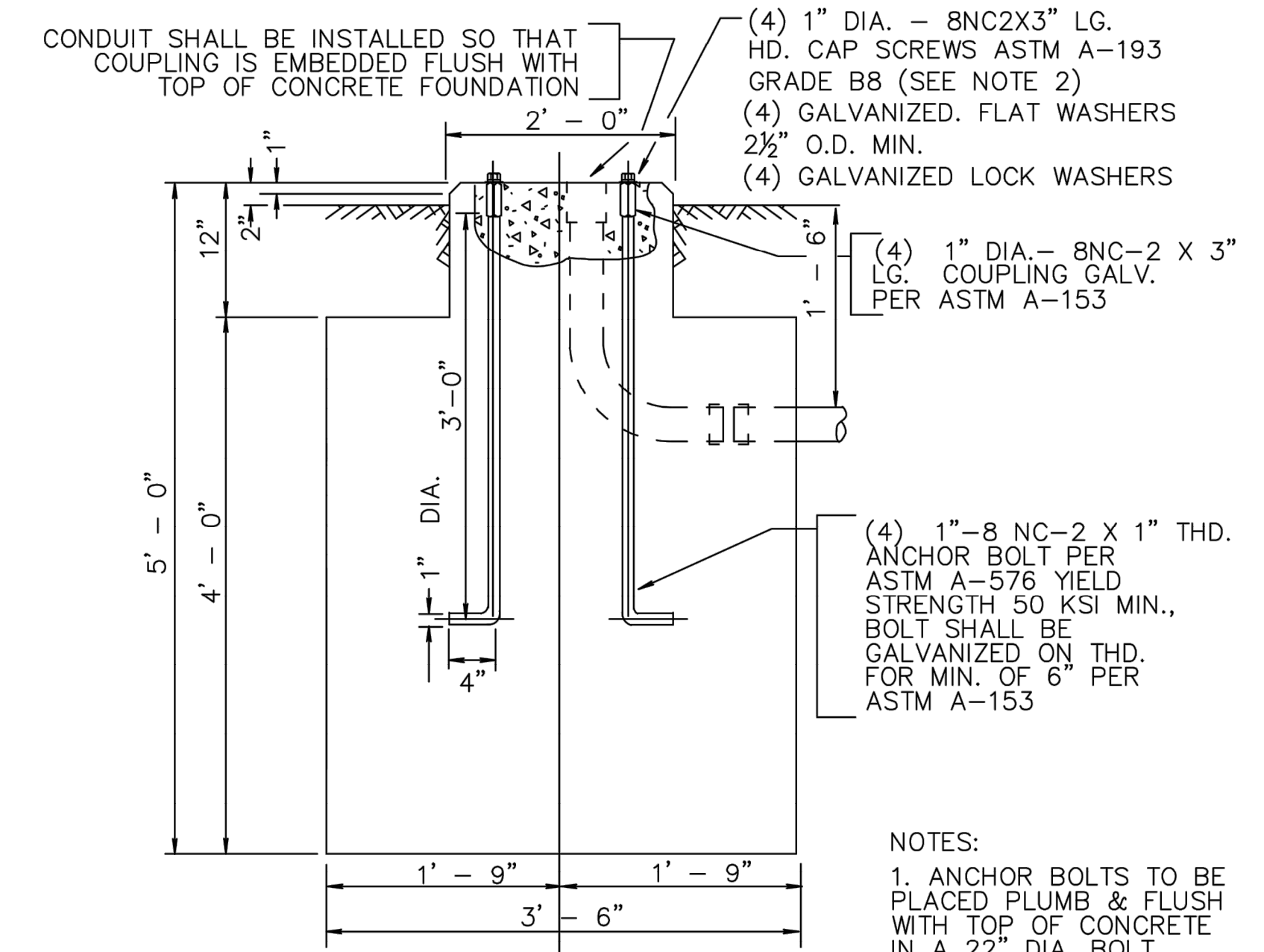
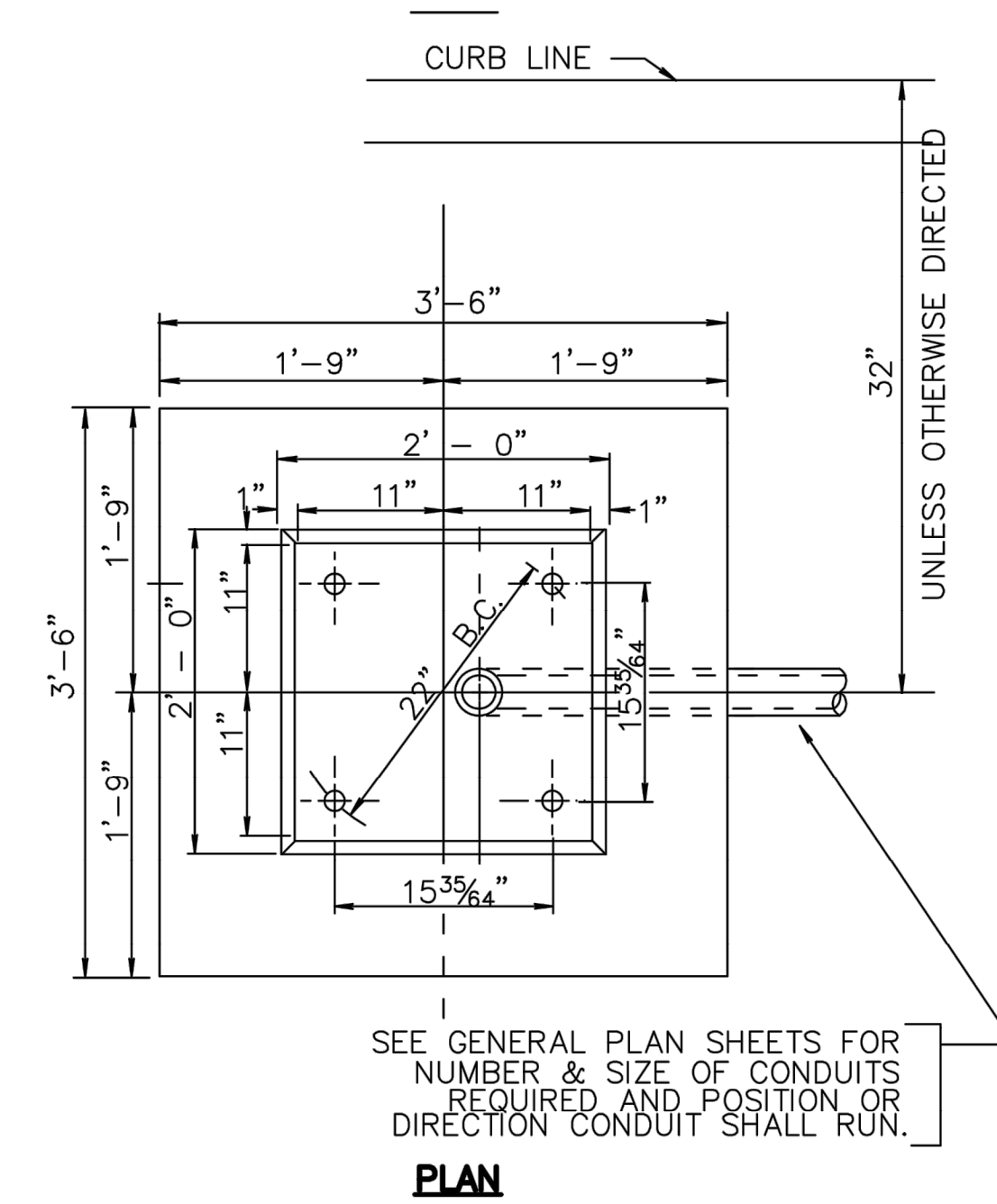

ELEVATION
FOUNDATION TYPE "SFK"

CONCRETE CLASS "C"
2 CU. YDS.
FOUNDATION SHALL BE POURED MONOLITHIC

- NOTES:
- ALL CONDUIT SHALL BE INSTALLED SO THAT COUPLINGS ARE EMBEDDED PLUMB & FLUSH WITH TOP OF CONCRETE FOUNDATION.
 - J-BOLT MUST BE INSERTED 1 1/2" ± 1/8" INTO 3" COUPLING.

REVISION	BY	C'K'D	DATE
UNION COUNTY, DIVISION OF ENGINEERING			
ELECTRICAL DETAILS			
TYPICAL FOUNDATION DETAILS			
COUNTY OF UNION 2325 SOUTH AVENUE SCOTCH PLAINS, NJ 07076			SHEET NO. 24 OF 31

THE LOUIS BERGER GROUP - Feb. 10, 2014 - 12:21pm - CAUD FILE: L:\TRANS\CP-2011\CCC 1263 Electrical\Signoff\CADD\UNCS\08-Construction\Details\08.dwg

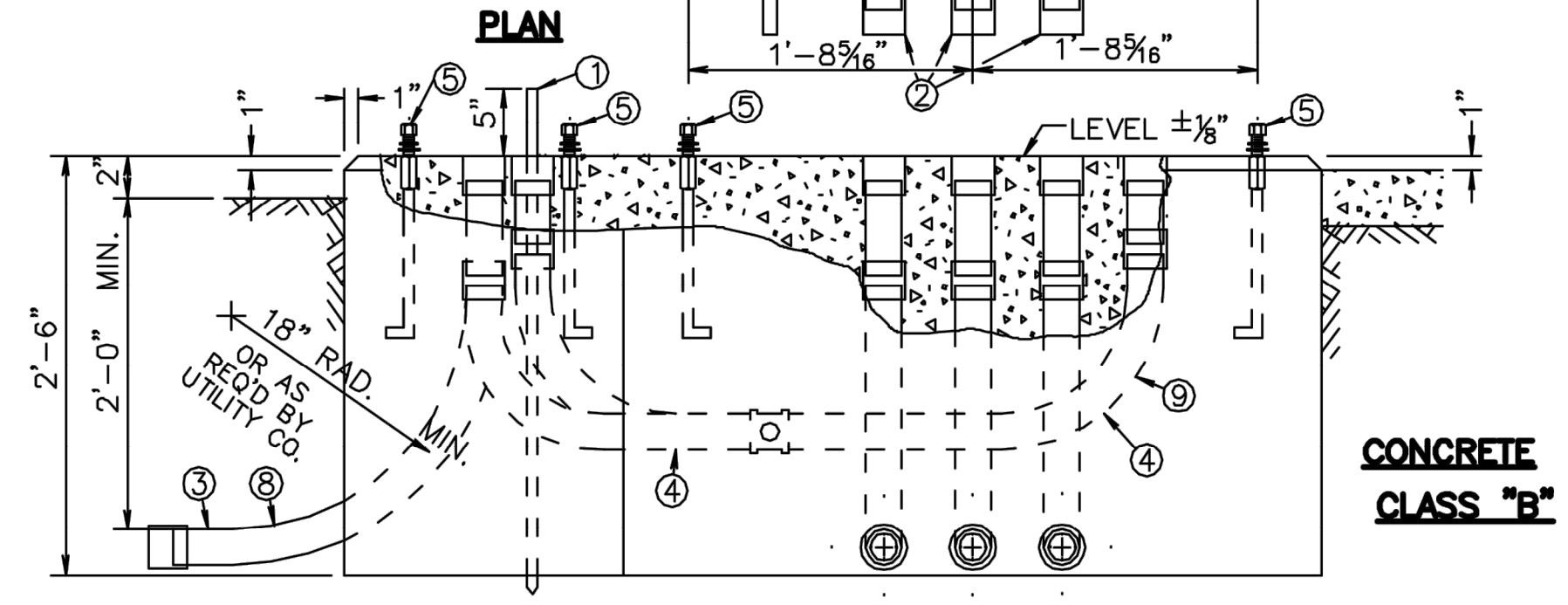
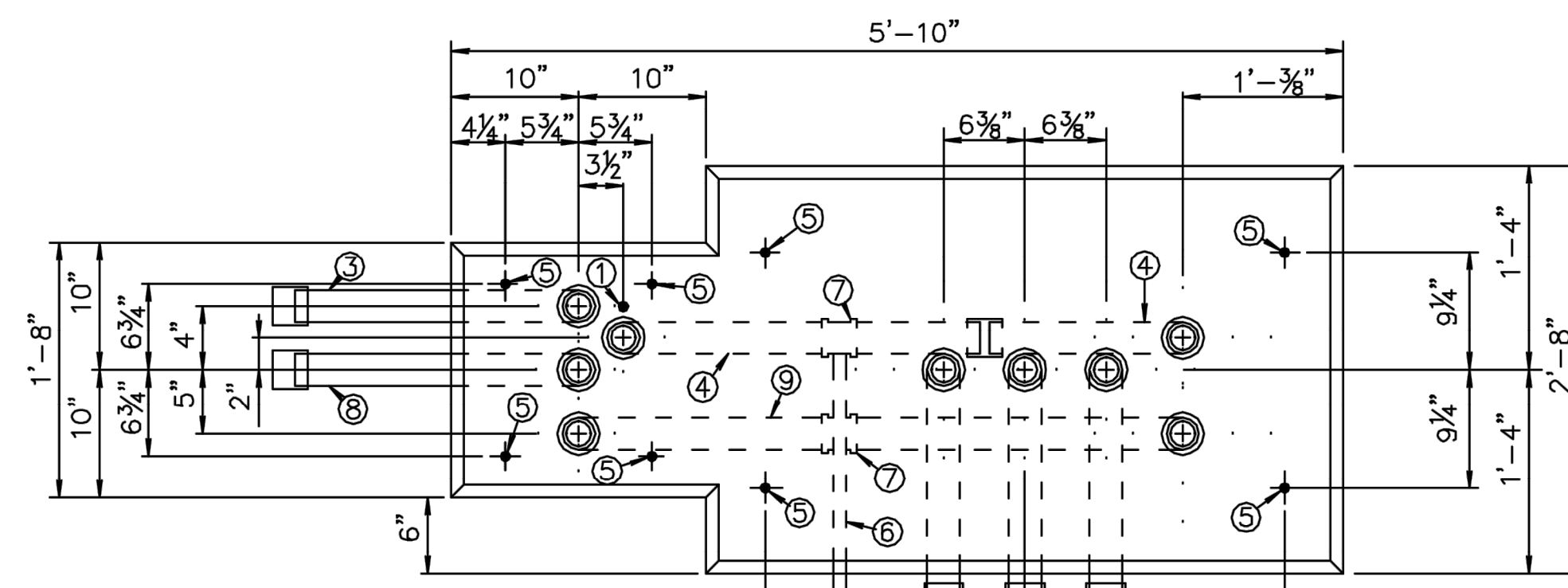

FOUNDATION TYPE "P-MC"

ITEM

- ① 5/8" X 12' LG. GROUND ROD.
- ② 3" DIA. RIGID METALLIC CONDUIT. (ALL SHALL EXTEND TO JUNCTION BOX)
- ③ RIGID METALLIC CONDUIT (SERVICE CONDUIT). SEE GENERAL PLAN FOR DIRECTION AND SIZE
- ④ 2" DIA. RIGID METALLIC CONDUIT (SERVICE CONDUIT)
- ⑤ 3/4" DIA. ANCHOR BOLTS (SEE "SPF" FOUNDATION FOR DETAILS)
- ⑥ DRAIN 1" DIA. RIGID METALLIC CONDUIT (PITCH TO JUNCTION BOX).
- ⑦ 2" X 2" X 1" GALV. TEE FITTING.
- ⑧ RIGID METALLIC CONDUIT (INTERCONNECT CONDUIT). SEE GENERAL PLAN FOR DIRECTION AND SIZE IF NOT SPECIFIED 2" DIA. RMC SHALL BE INSTALLED.
- ⑨ 2" DIA. RIGID METALLIC CONDUIT (INTERCONNECT CONDUIT)

NOTES:

1. ALL CONDUIT SHALL BE INSTALLED SO THAT COUPLINGS ARE EMBEDDED PLUMB AND FLUSH WITH TOP OF CONCRETE FOUNDATION.
2. J-BOLT MUST BE INSERTED 1/2" ± 1/16" INTO 3" COUPLING
3. ALL FOUNDATIONS SHALL BE POURED MONOLITHIC

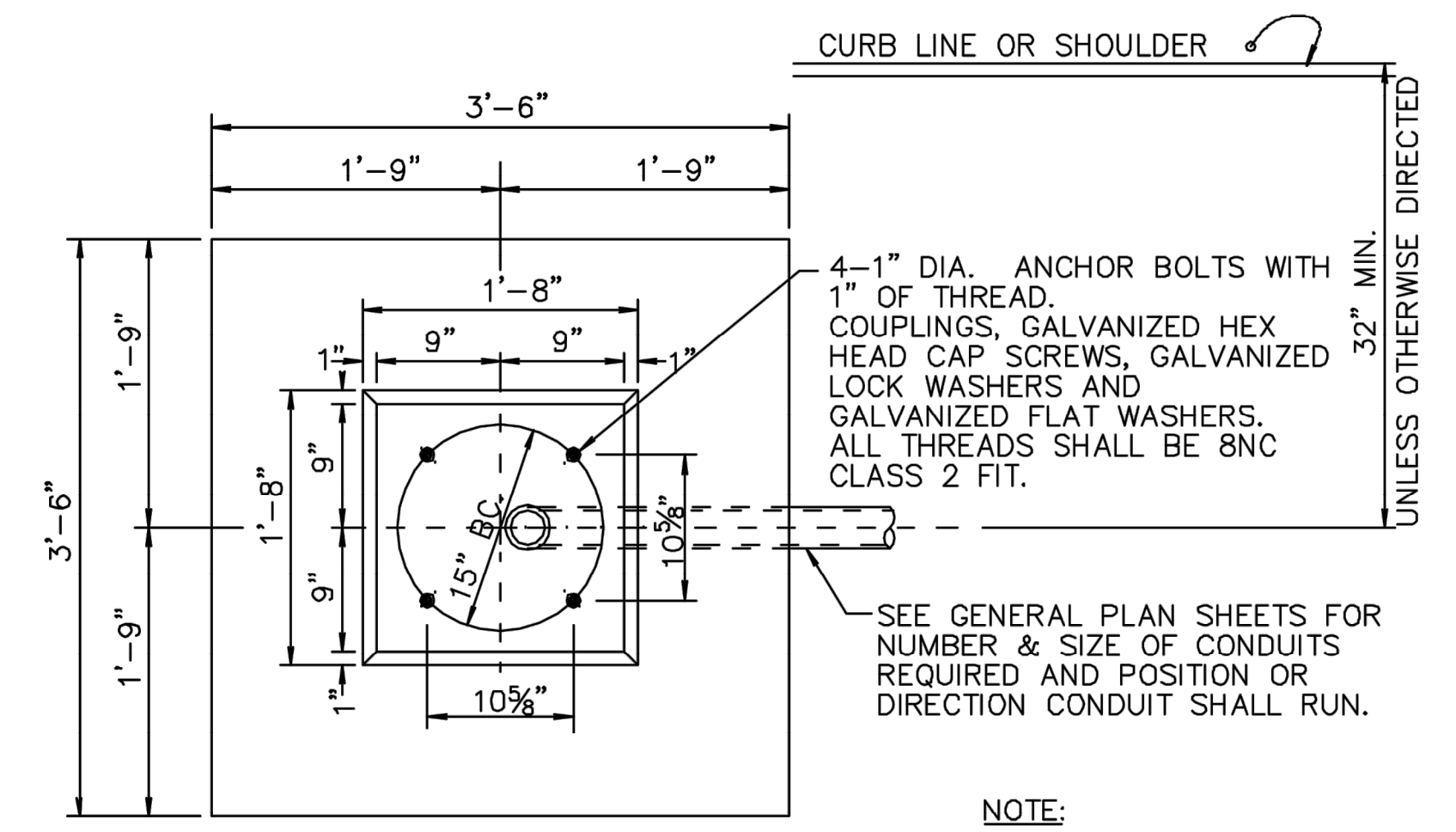

4-1" DIA. ANCHOR BOLTS WITH 1" OF THREAD. COUPLINGS, GALVANIZED HEX HEAD CAP SCREWS, GALVANIZED LOCK WASHERS AND GALVANIZED FLAT WASHERS. ALL THREADS SHALL BE 8NC CLASS 2 FIT.

SEE GENERAL PLAN SHEETS FOR NUMBER & SIZE OF CONDUITS REQUIRED AND POSITION OR DIRECTION CONDUIT SHALL RUN.

NOTE:
CONCRETE CLASS "C" 2 CU. YDS.
FOUNDATION SHALL BE POURED MONOLITHIC

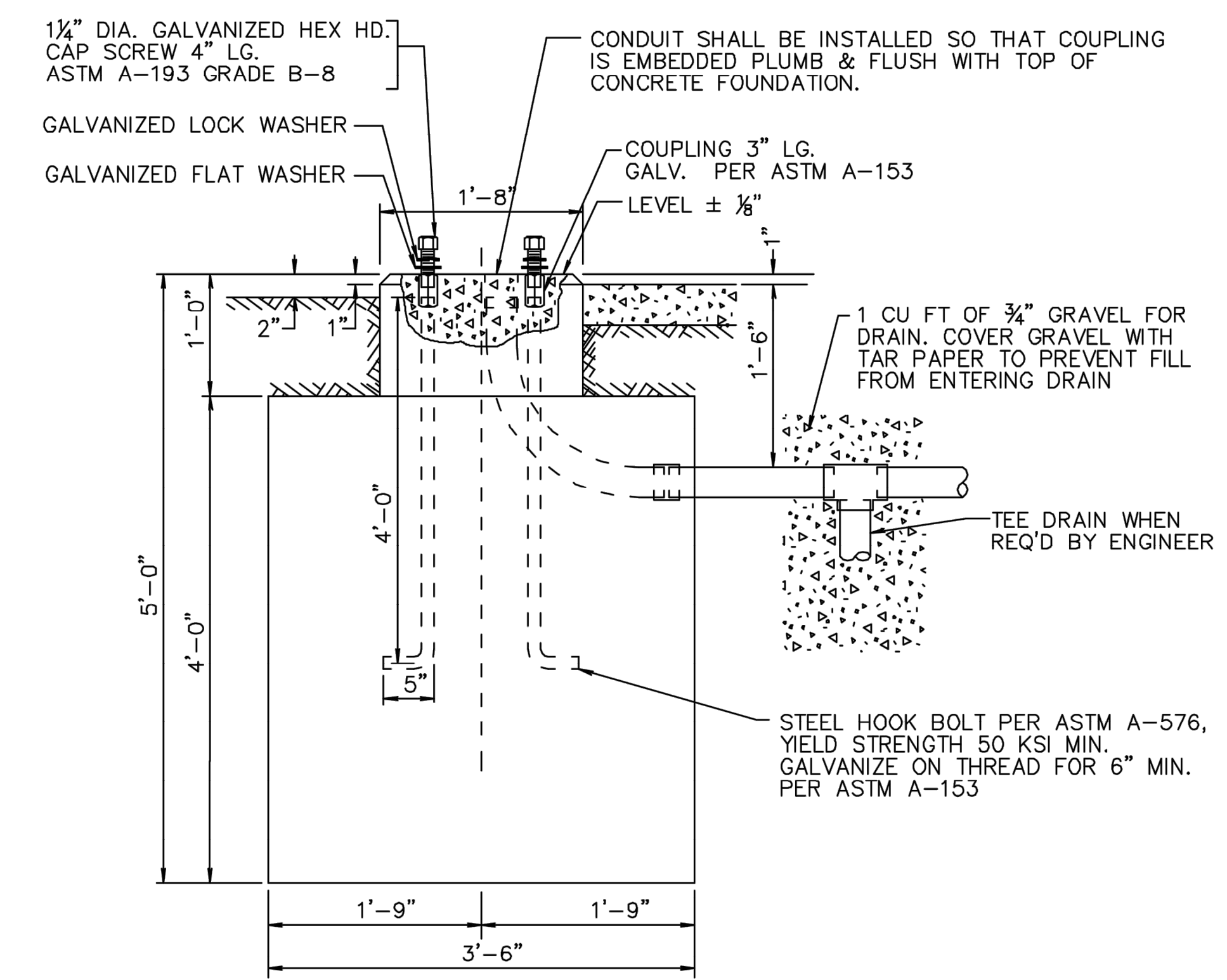

ELEVATION
STANDARD FOUNDATION TYPE SFT-H

THE LOUIS BERGER GROUP - Feb 10, 2014 - 12:28pm - CAD FILE: L:\TRANS\CP-2011\CCC 1263 Elizabeth Signs\CAD\DWG\08- Construction Details\07.dwg

REVISION	BY	C/K'D	DATE
UNION COUNTY, DIVISION OF ENGINEERING			
ELECTRICAL DETAILS			
TYPICAL FOUNDATION DETAILS			
COUNTY OF UNION 2325 SOUTH AVENUE SCOTCH PLAINS, NJ 07076			SHEET NO. 25 OF 31

THE LOUIS BERGER GROUP - Feb 10, 2014 - 12:31pm - CAD FILE: L:\TRANS\CP-2011\CCC 1283 Electrical Symbols\CADD\DWG\08-Construction\Details\09.dwg

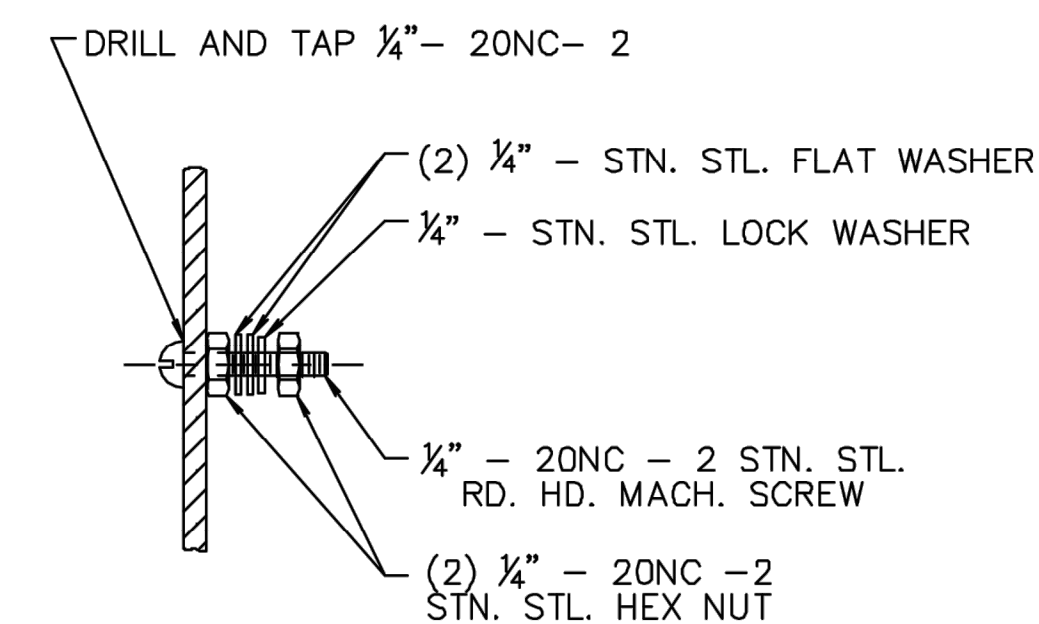
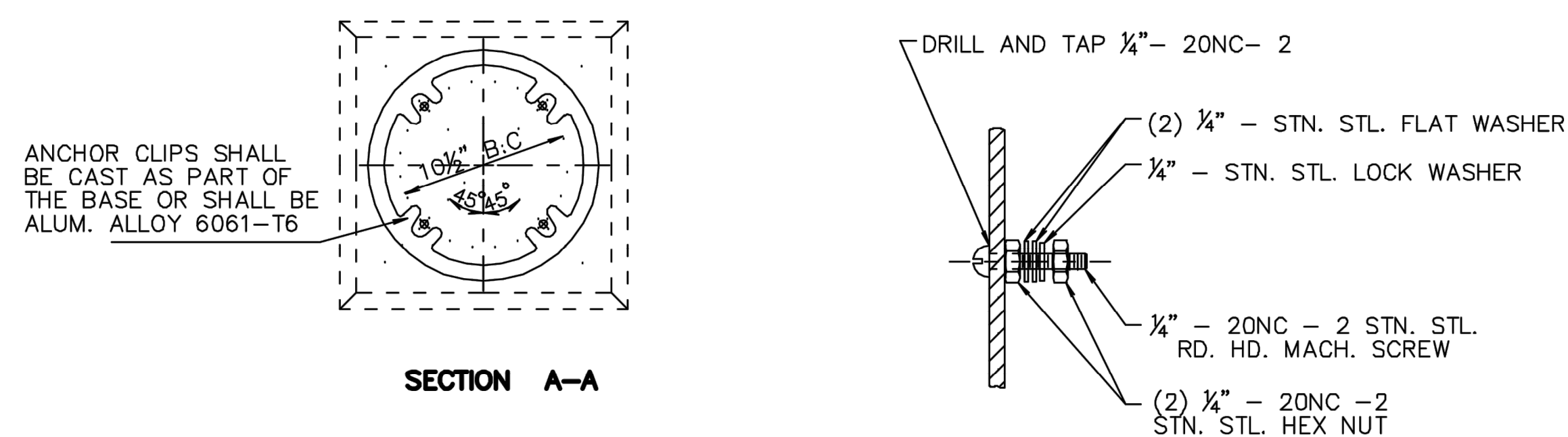

**GROUND STUD DETAIL
OPPOSITE DOOR OPENING**

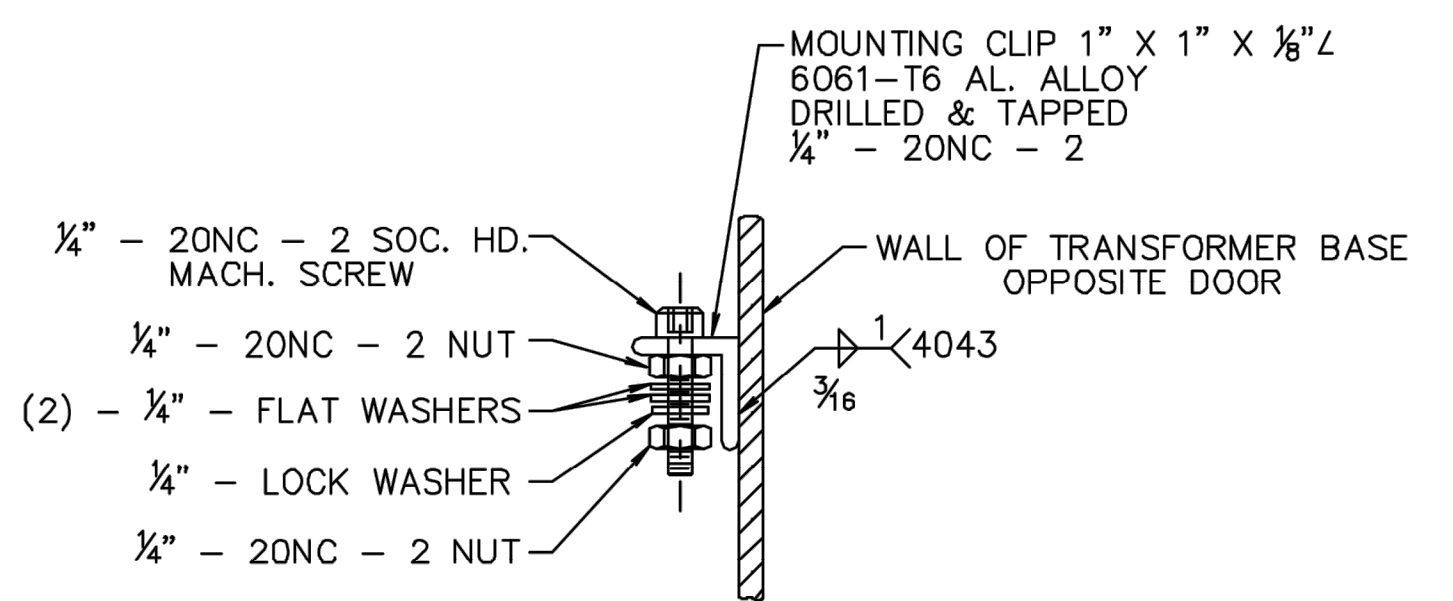

**ALTERNATE DETAIL "B"
GROUND STUD DETAIL
OPPOSITE DOOR OPENING**

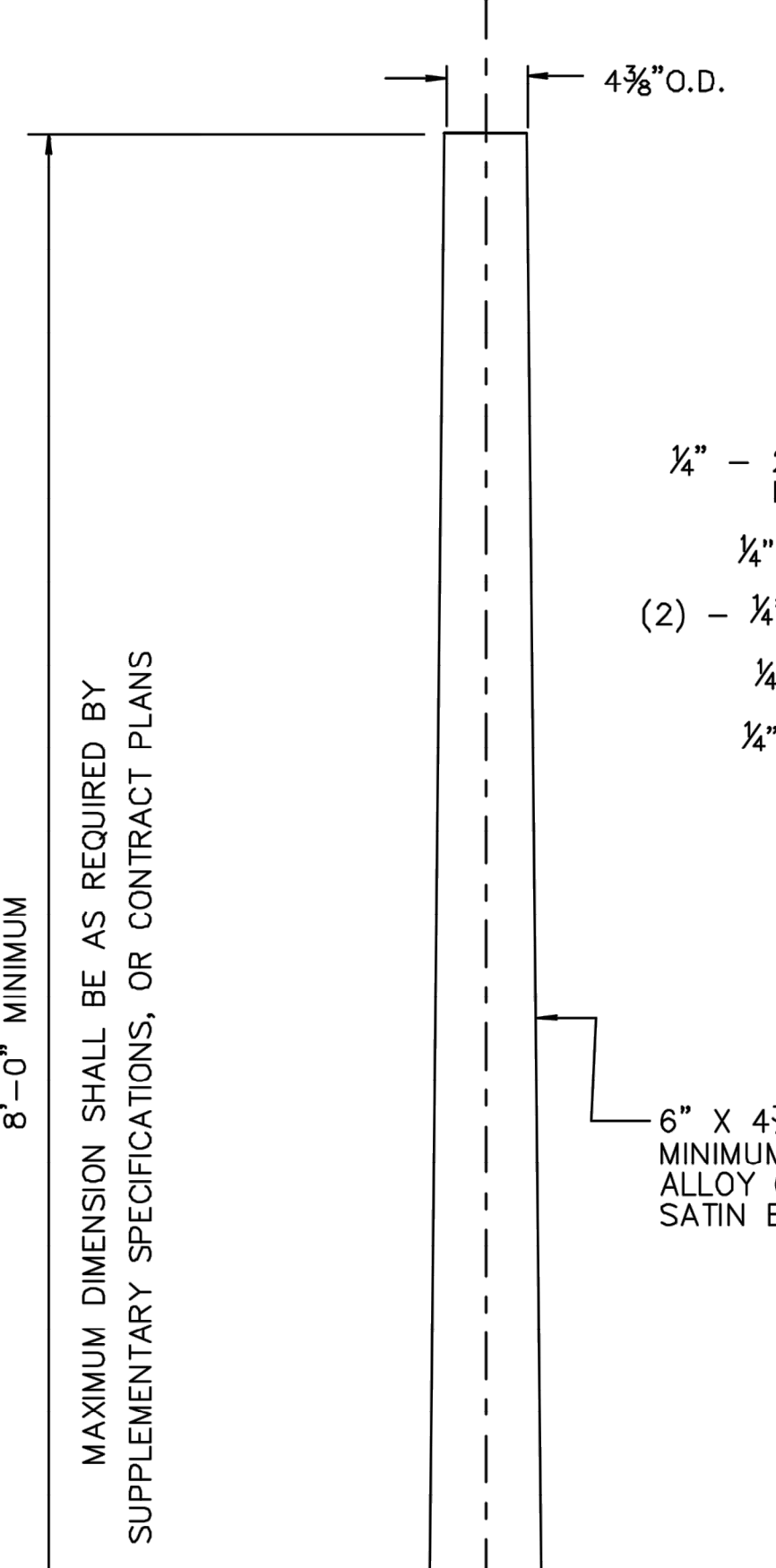

FURNISH WITH EACH PEDESTAL

- 4 - 3/4" STD. HEX. HEAD BOLT } SEE ANCHOR BOLT
- 4 - 3/4" STD. PLAIN WASHER } DETAIL FOR TYPE

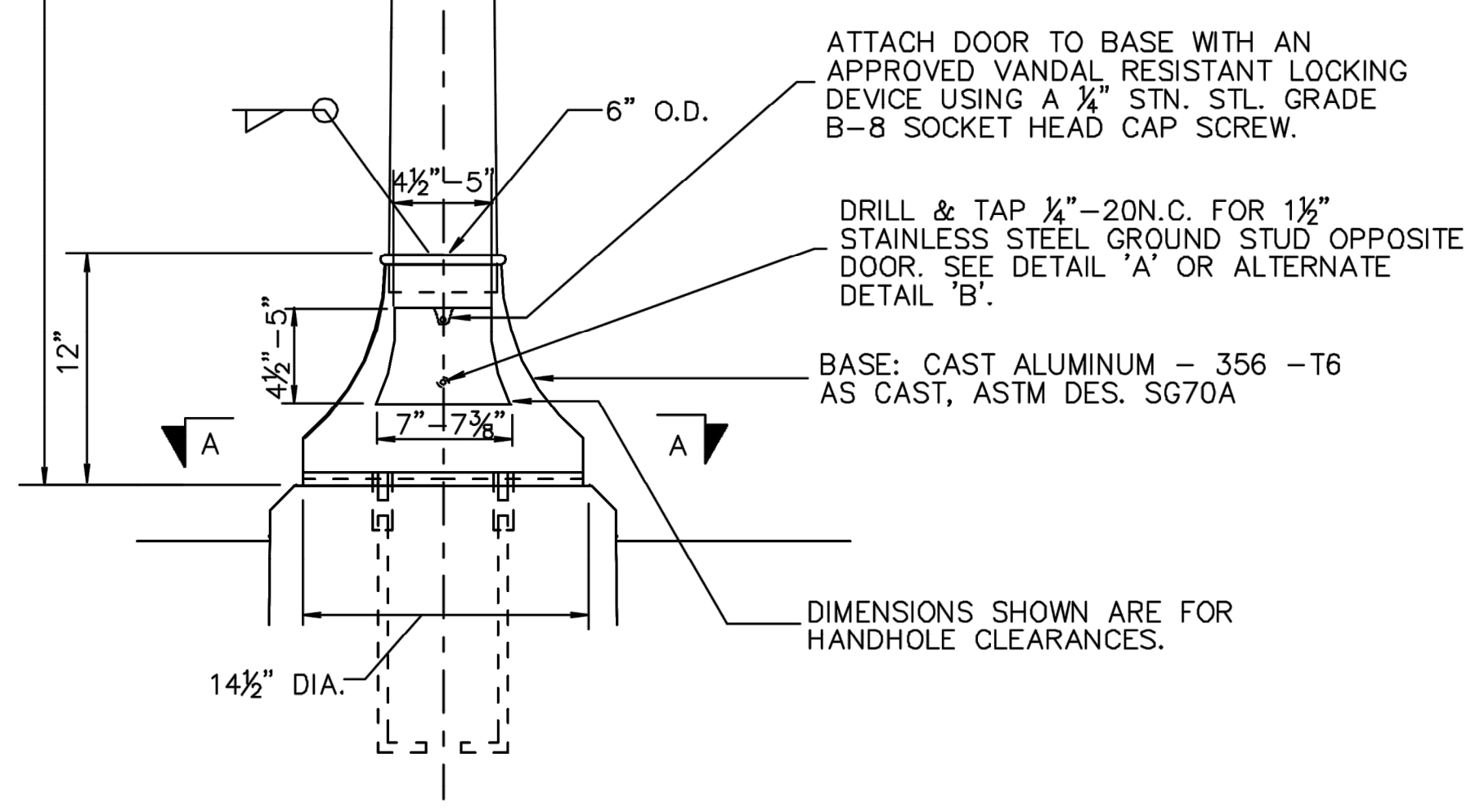

TRAFFIC SIGNAL PEDESTAL

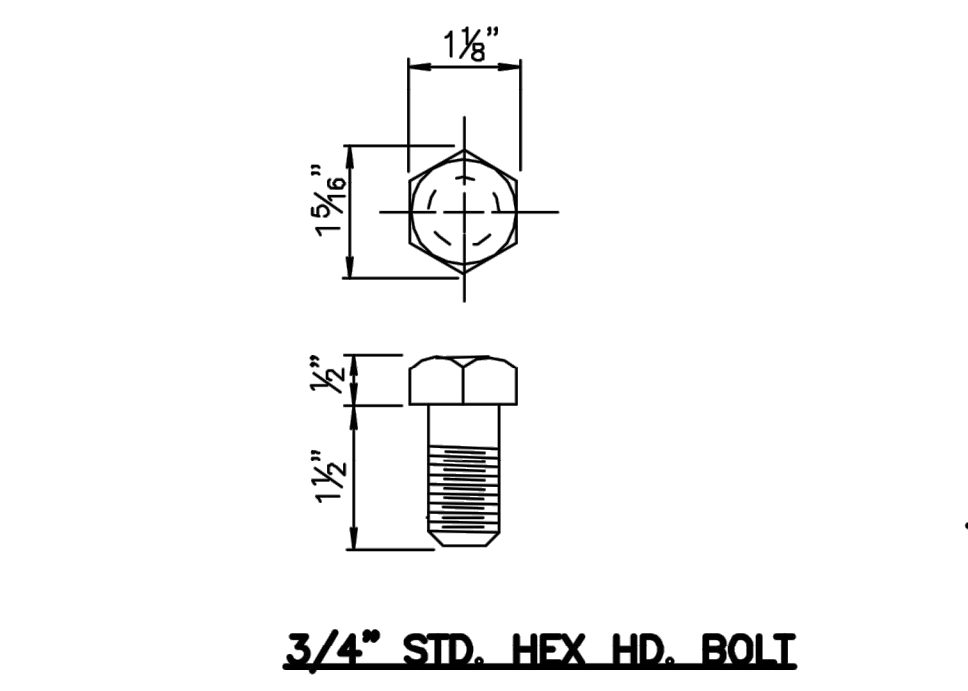

3/4" STD. HEX HD. BOLT
STAINLESS STEEL ASTM A-193 GRADE B8
U.S. STANDARD THREADS 10 PER INCH
4- REQ'D. PER PEDESTAL

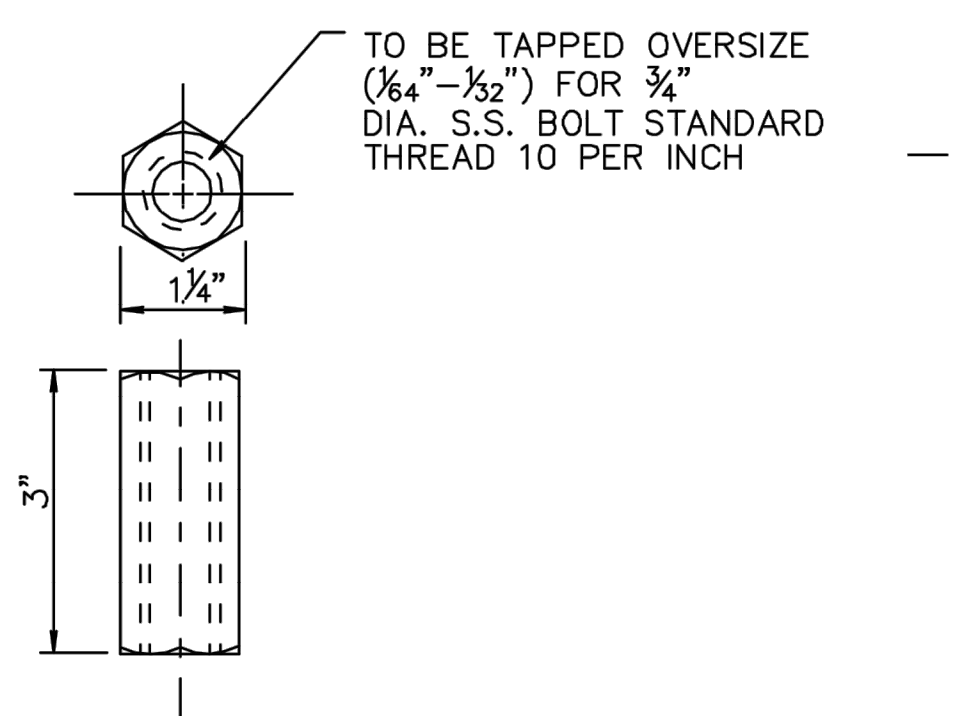

HEX STEEL ROD COUPLING
GALVANIZED PER ASTM A-153
3/4" U.S. STD. THREADS (SEE NOTE ABOVE)
1 1/2" HEX STOCK 4-REQ'D. PER PEDESTAL

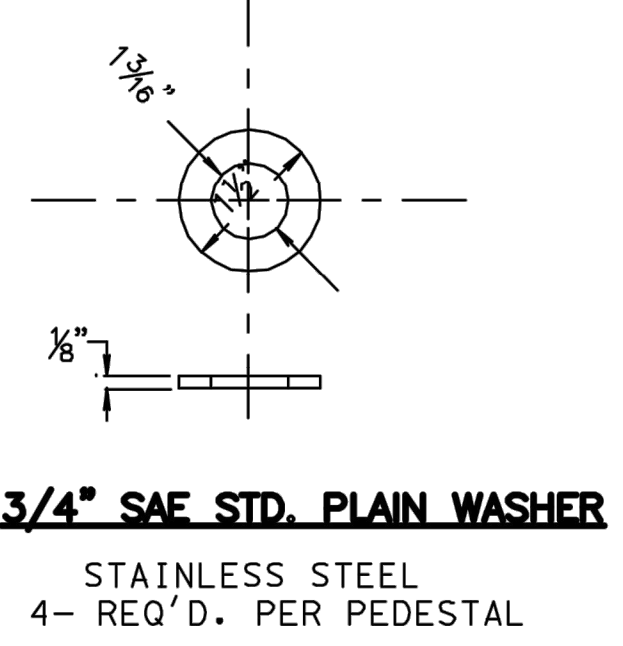

3/4" SAE STD. PLAIN WASHER
STAINLESS STEEL
4- REQ'D. PER PEDESTAL

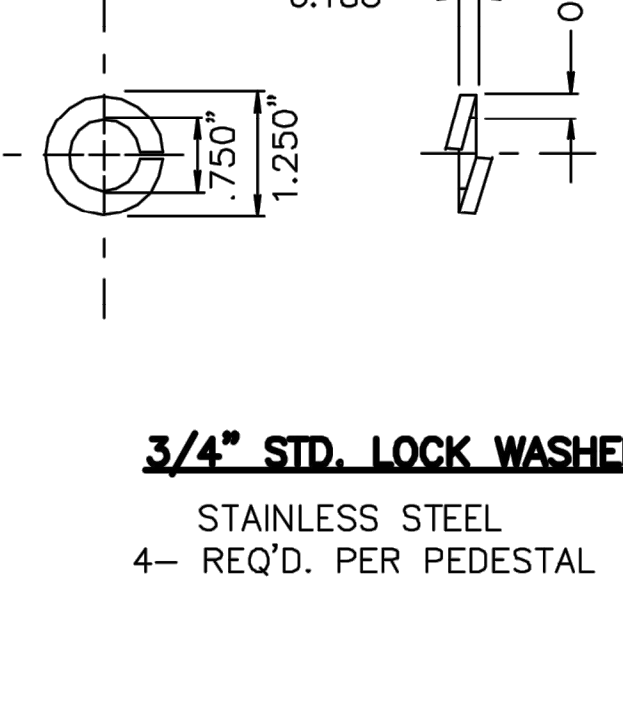

3/4" STD. LOCK WASHER
STAINLESS STEEL
4- REQ'D. PER PEDESTAL

ANCHOR BOLT DETAIL

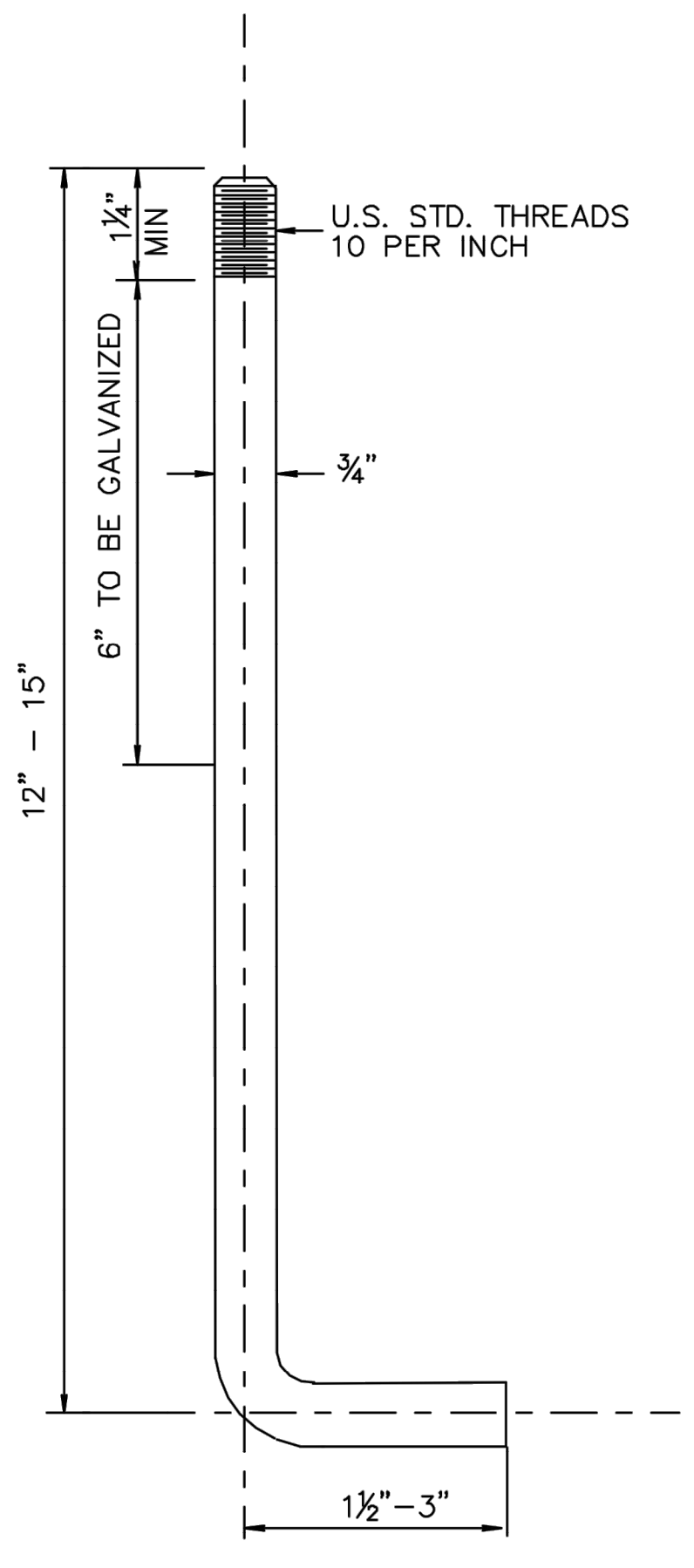

3/4" DIA. ANCHOR BOLT
STEEL PER ASTM A-576
4- REQ'D. PER PEDESTAL
TOP 6" SHALL BE GALVANIZED
PER ASTM A-153

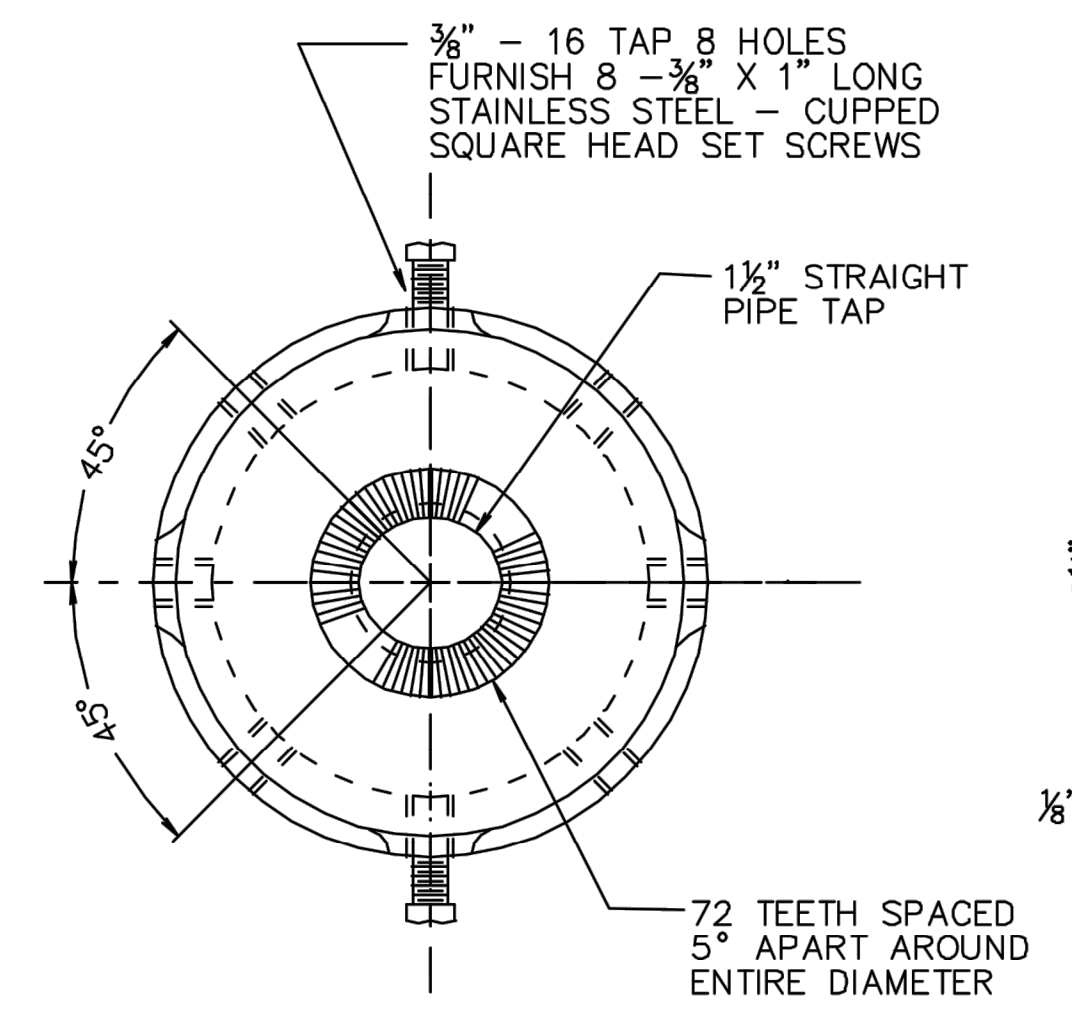

SLIP FITTER DETAIL
MATERIAL: ALUMINUM ALLOY 356

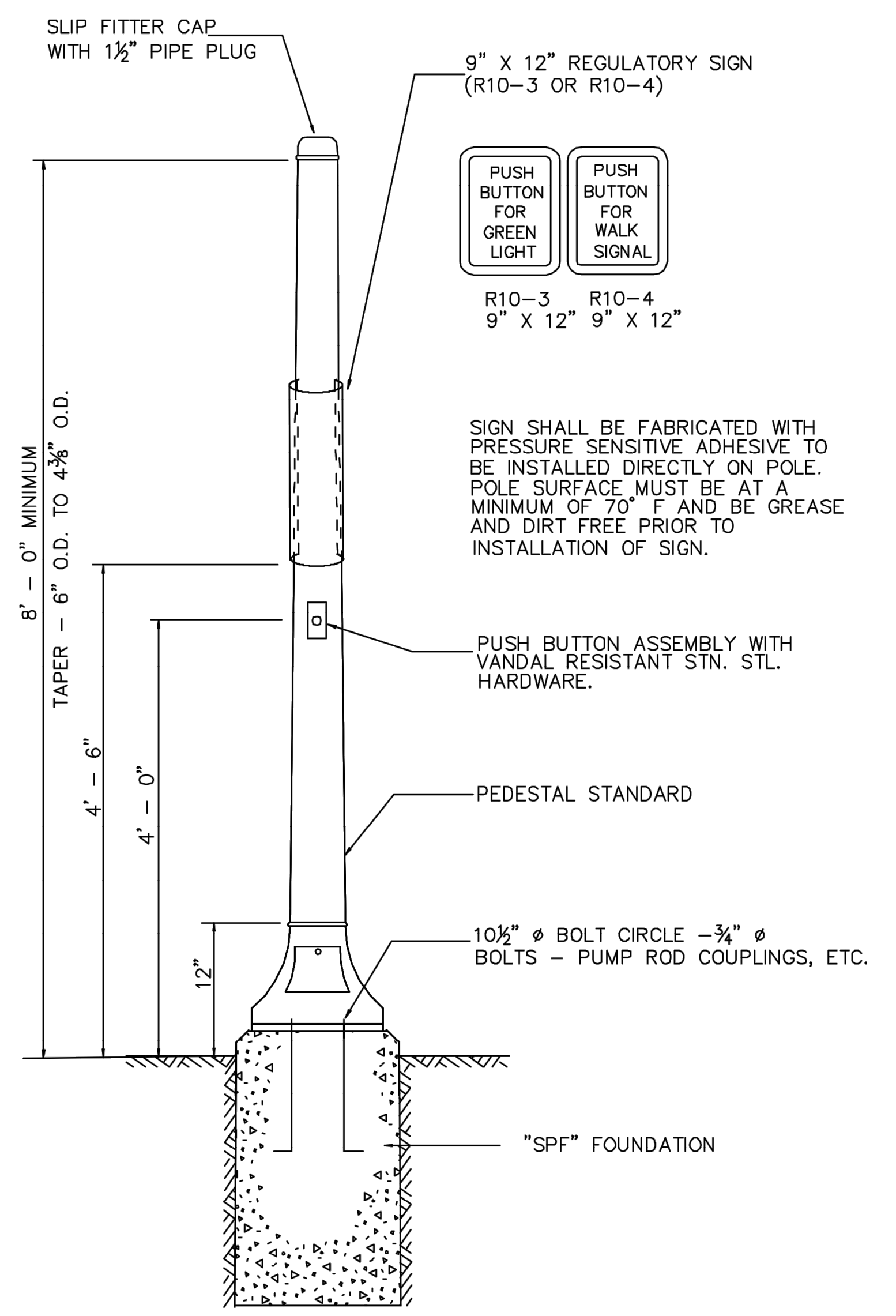
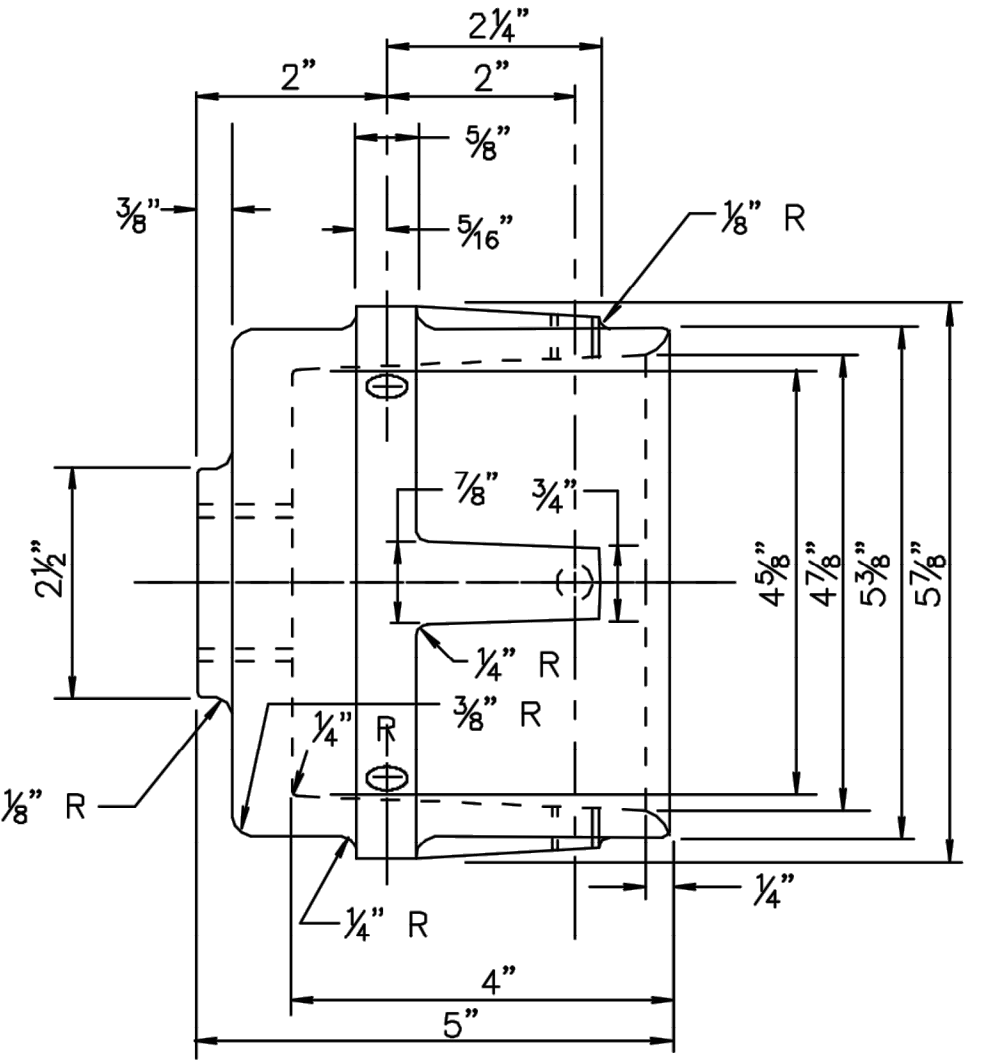

**TYPICAL PUSH BUTTON STANDARD
PUSH BUTTON ASSEMBLY INSTALLED**

- NOTES:**
1. PEDESTAL STANDARDS SHALL BE MANUFACTURED IN ACCORDANCE WITH AASHTO STANDARD SPECIFICATIONS FOR STRUCTURAL SUPPORTS FOR HIGHWAY SIGNS, LUMINAIRES AND TRAFFIC SIGNALS.
 2. ALL TOLERANCES OF CASTINGS SHALL BE ±1/32".

REVISION	BY	C'K'D	DATE
UNION COUNTY, DIVISION OF ENGINEERING			
ELECTRICAL DETAILS			
SIGNAL DETAILS			
COUNTY OF UNION 2325 SOUTH AVENUE SCOTCH PLAINS, NJ 07076			SHEET NO. 26 OF 31

THE LOUIS BERGER GROUP - Feb 10, 2014 - 12:45pm - CAD FILE: L:\TRANS\CP-2011\CCC 1283 Elizabeth Signals\CADD\DWGS\08-Construction\Details\017.dwg

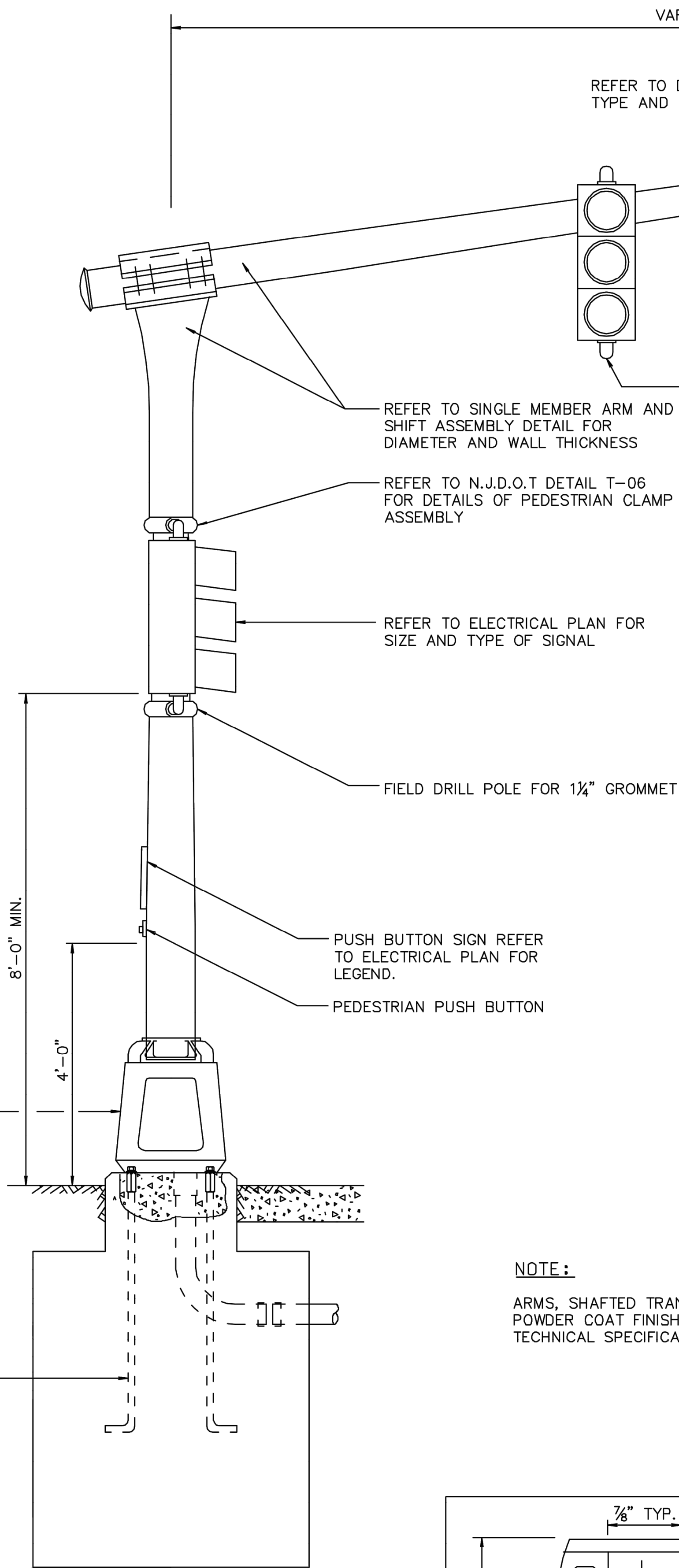

TYPICAL INSTALLATION

ITEM	PELCO PART NO.	DESCRIPTION	COAT	QTY
	AB-0116-L-L	STANDARD ASTRO-BRAC ASSY. FOR 3, 4 OR 5 SECTION SIGNAL*		1
1	AB-3004-L	STD. ASTRO-BRAC CLAMP KIT (-L = BAND LENGTH)	ALO	1
2	AB-2003-L	GUSSET TUBE W/ VINYL INSERT (-L = TUBE LENGTH)	ALO	1
3	AB-4000	STANDARD ARM KIT		1
4	AB-0214	STANDARD UPPER ARM, 9"	ALO	1
5	AB-0205	HARDWARE KIT, STANDARD ARM	ZN2	1
6	AB-0215	STANDARD LOWER ARM, 9"	ALO	1
7	AB-0216	PLASTIC COVER, LOWER ARM	PNC	1

NOTE:
ARMS, SHAFTED TRANSFORMER BASE SHALL HAVE A POWDER COAT FINISH IN CONFORMANCE WITH THE TECHNICAL SPECIFICATIONS.

MATERIAL COATING LEGEND

COATING	CODE
Alodine	ALO
Black Oxide	BOX
Brass	BRS
Chroma	CRM
Galvanized	GLV
No Coating	PNC
Zinc Bright	ZN1
Zinc Yellow	ZN2
Zinc Ultra-Seal	ZN3
Painted	PXX

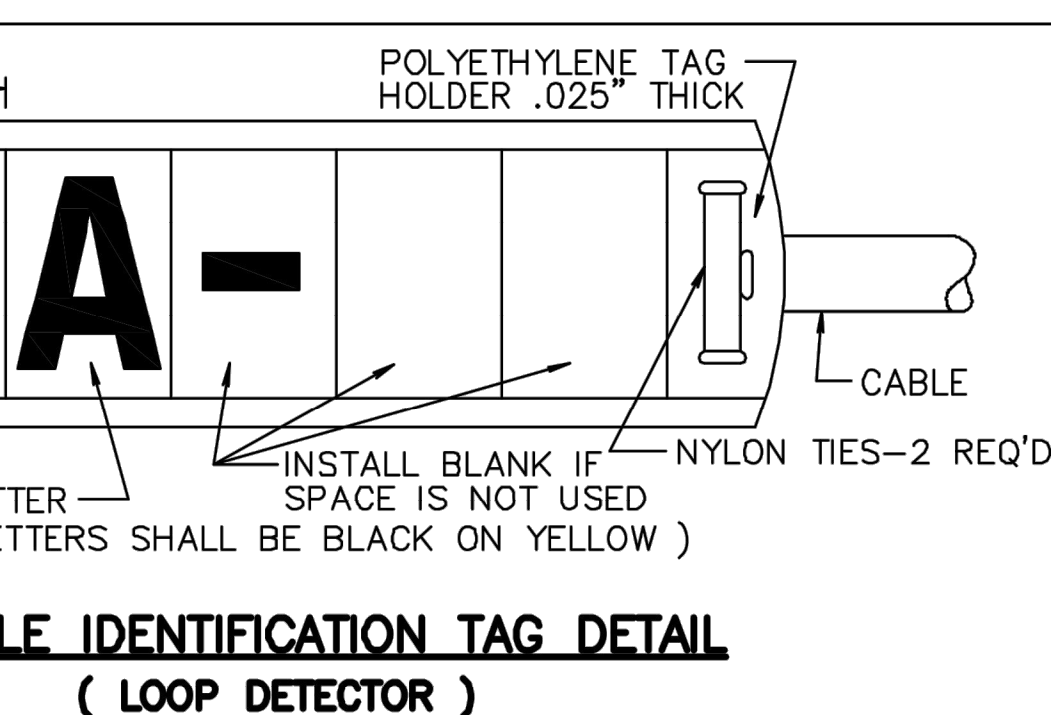

CABLE IDENTIFICATION TAG DETAIL (LOOP DETECTOR)

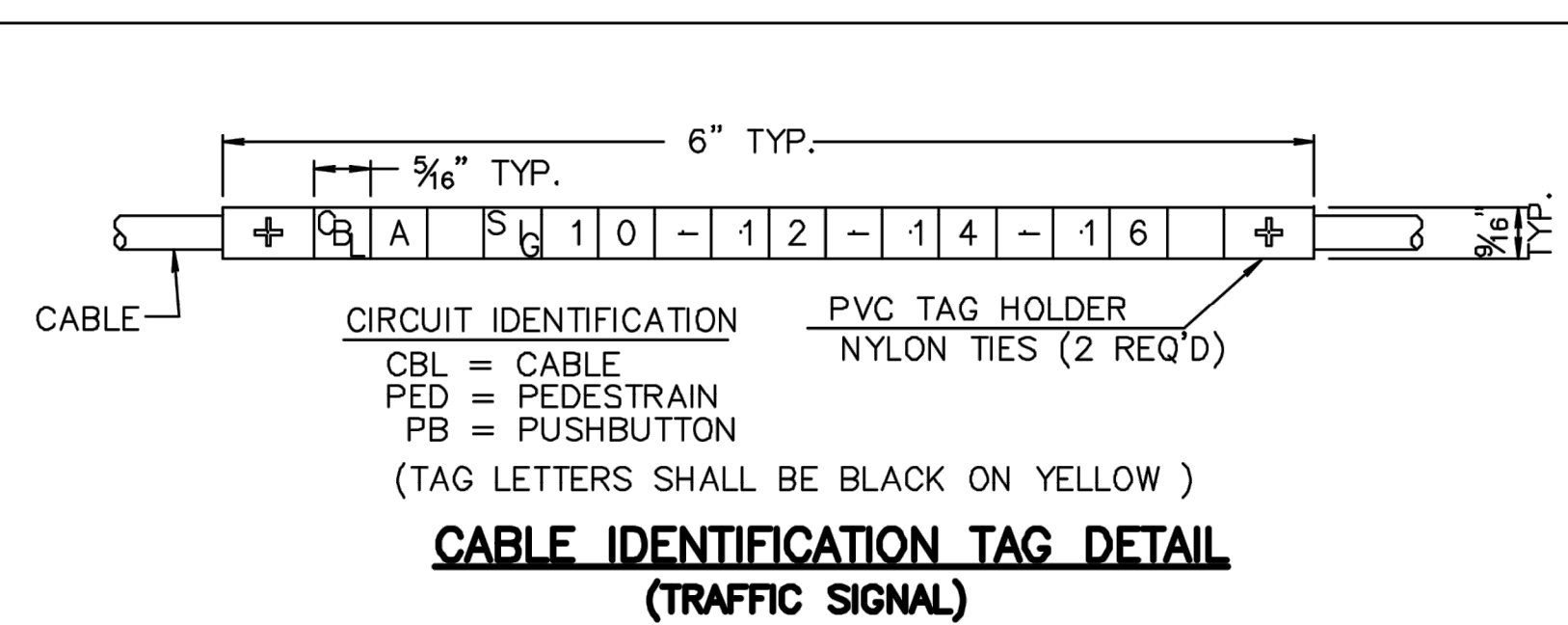

CABLE IDENTIFICATION TAG DETAIL (TRAFFIC SIGNAL)

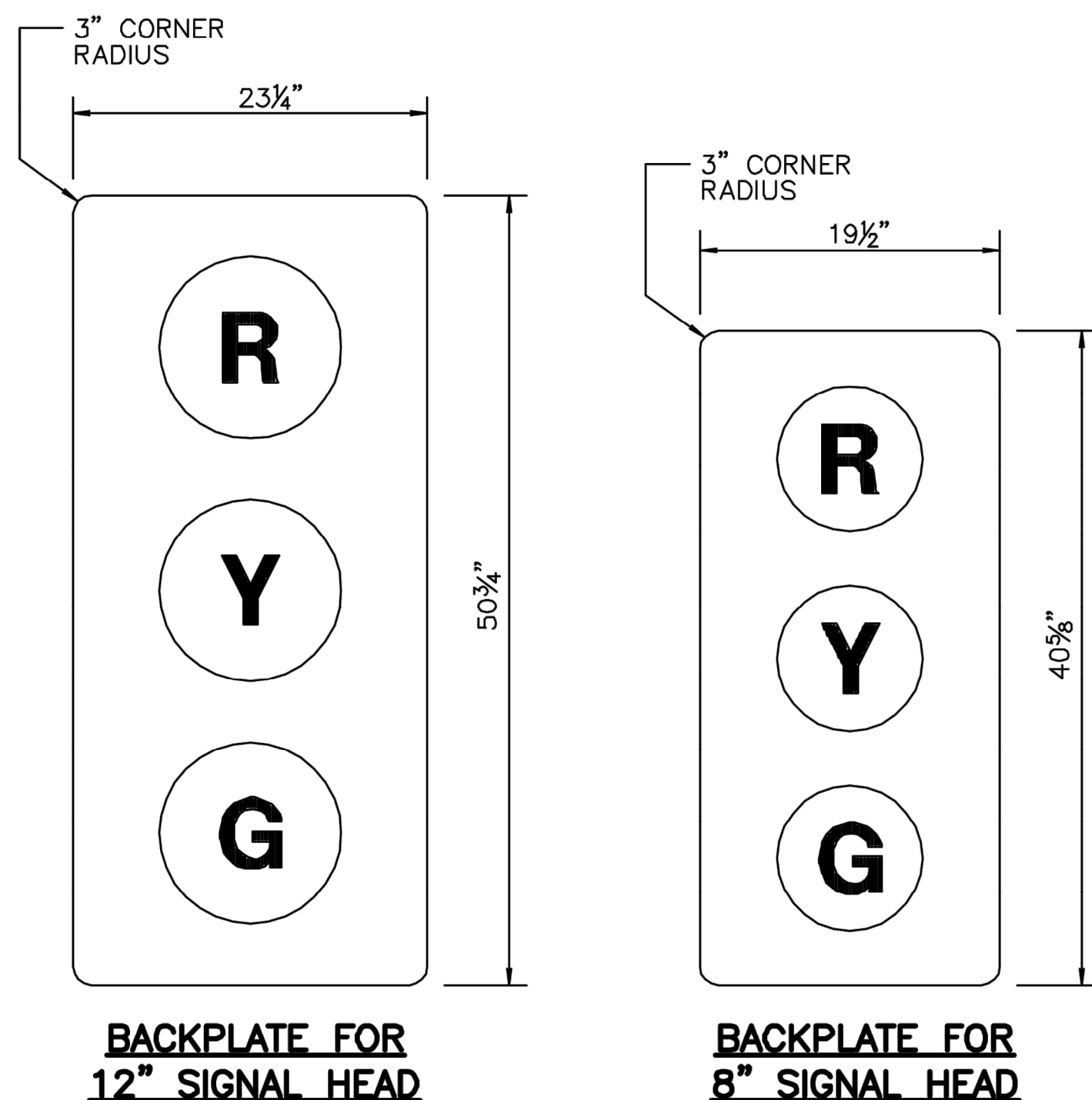

BACKPLATE FOR 12" SIGNAL HEAD and **BACKPLATE FOR 8" SIGNAL HEAD**

NOTES:
- MATERIAL : .125 BLACK ABS WITH HAIRCELL FINISH FRONT SIDE.
- FABRICATION: VACUUM FORMED.
- BACKPLATES SHALL CONFORM TO THE MANUAL ON UNIFORM TRAFFIC CONTROL DEVICES.
- IF A BACKPLATE IS USED, THE CLEARANCE SHALL BE 15'-6" MINIMUM FROM THE BOTTOM OF THE BACKPLATE TO THE FINISHED GRADE OF ROADWAY.

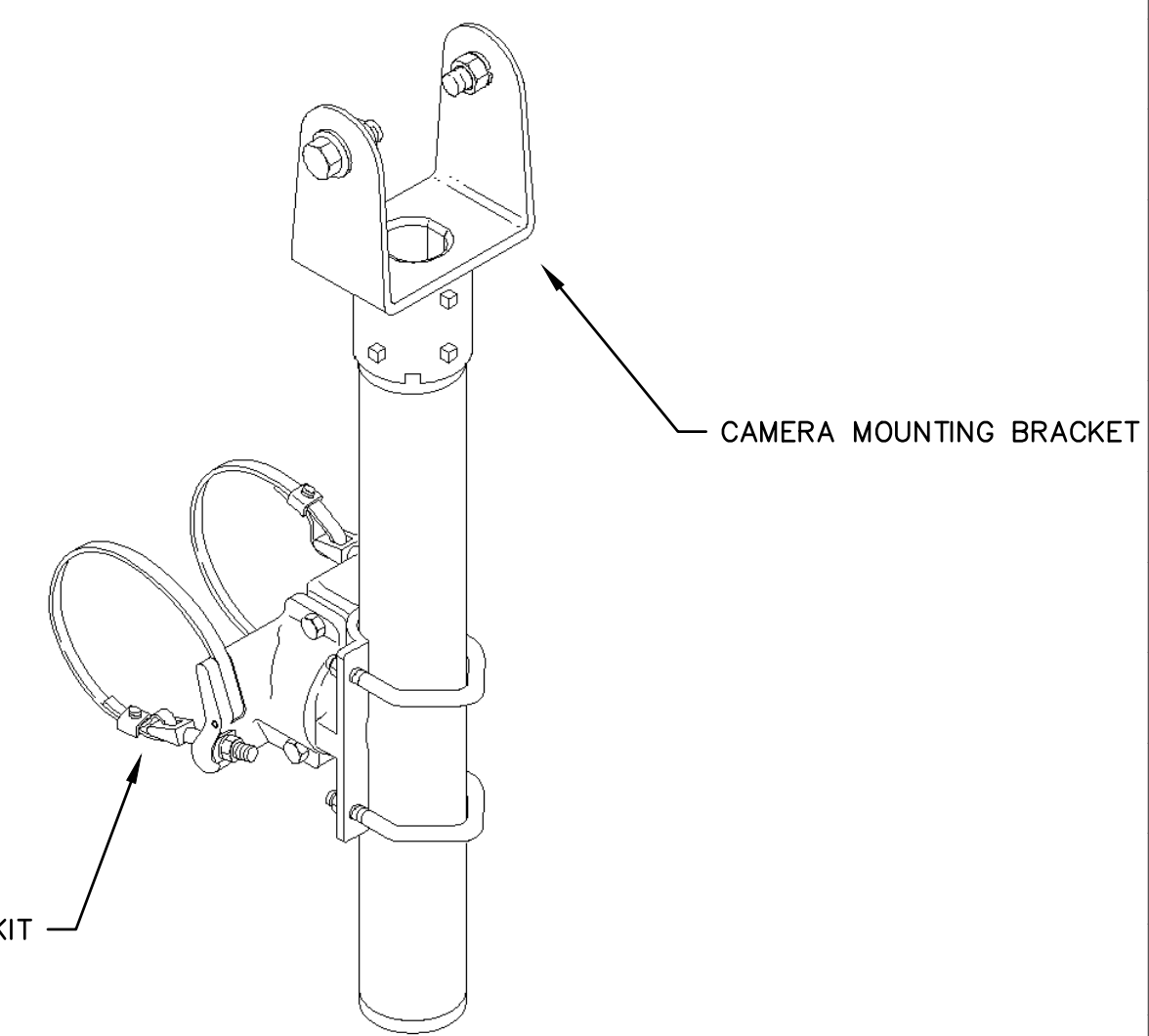

VIDEO DETECTION CAMERA BRACKET OPTIONS
TUBE LENGTH: 23", 37", 46", OR 74"
BAND LENGTH: 29", 36", 42", 48", OR 56"
STAINLESS UPGRADE
PAINT

VIDEO DETECTION CAMERA BRACKET
NOT TO SCALE

REVISION	BY	DATE
	C'K'D	

UNION COUNTY, DIVISION OF ENGINEERING

ELECTRICAL DETAILS

TRAFFIC SIGNAL STANDARD

COUNTY OF UNION
2325 SOUTH AVENUE
SCOTCH PLAINS, NJ 07076

SHEET NO. 27 OF 31

THE LOUIS BERGER GROUP - Feb 10, 2014 - 12:57pm - CAD FILE: L:\TRANS(OP-2011)\CCG 1283 Elizabeth Signs\CAD\DWGS\08-Construction Details\019.dwg

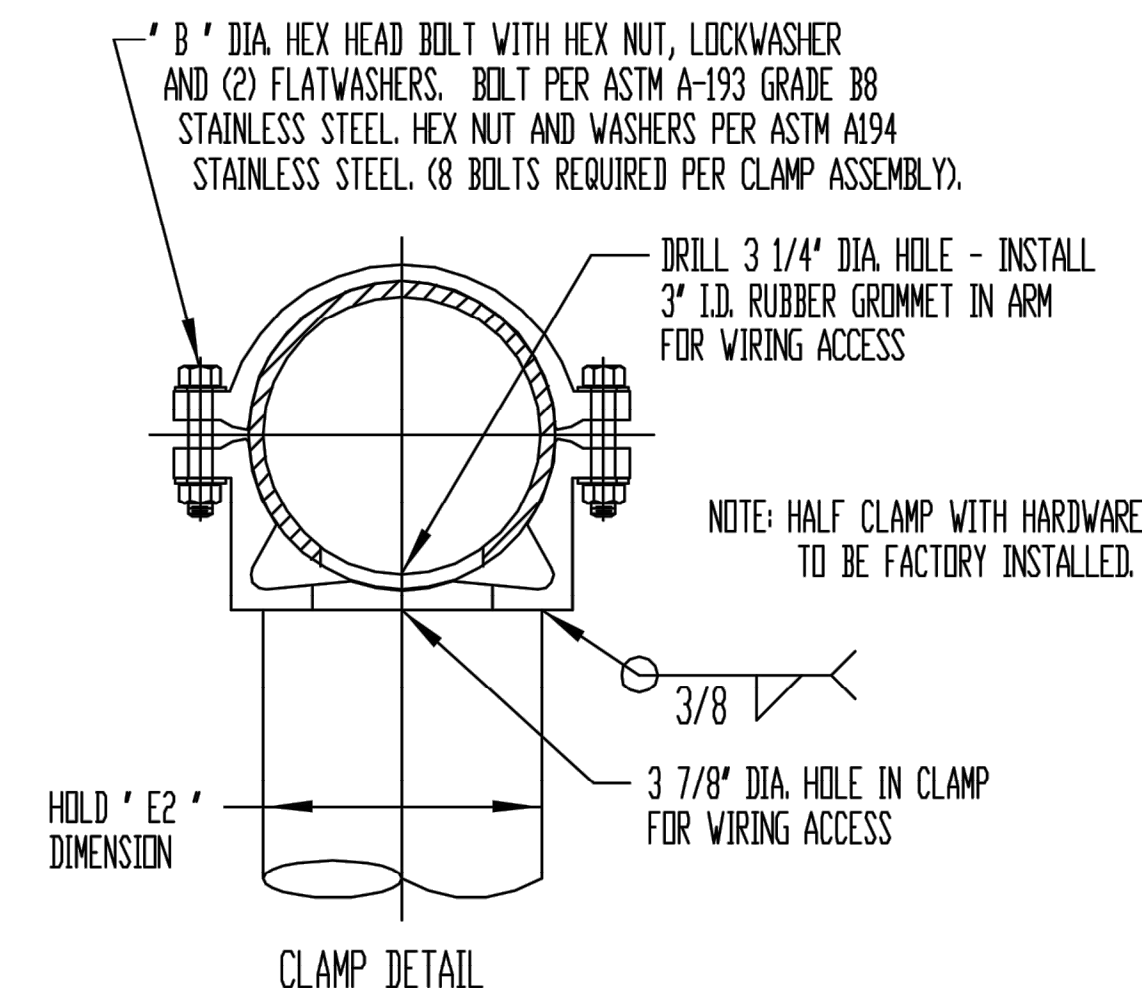
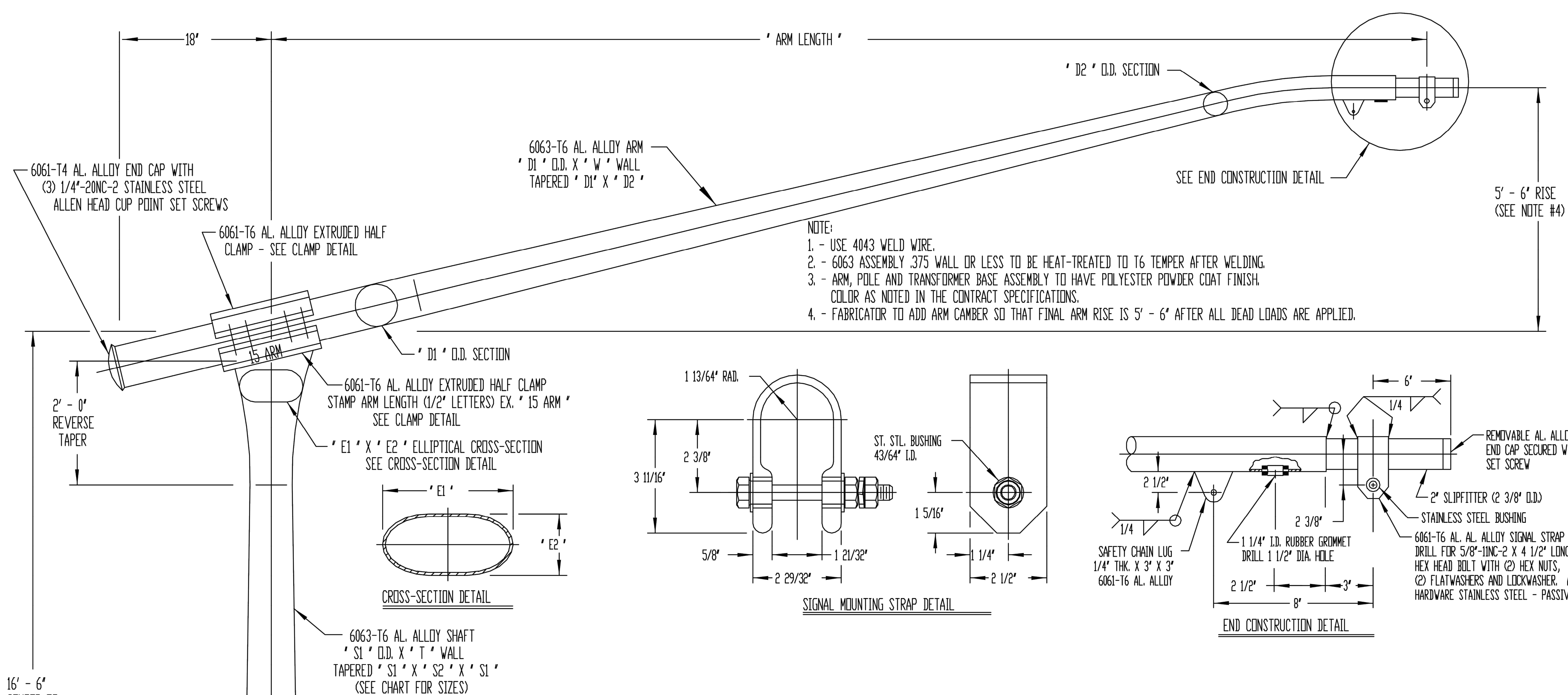

ARM SIZE	'E2'	'B'
6 5/8" O.D. X .156 WALL	5 7/8"	5/8"
8" O.D. X .156 WALL	8"	5/8"
8" O.D. X .188 WALL	8"	5/8"
10" O.D. X .188 WALL	9"	3/4"

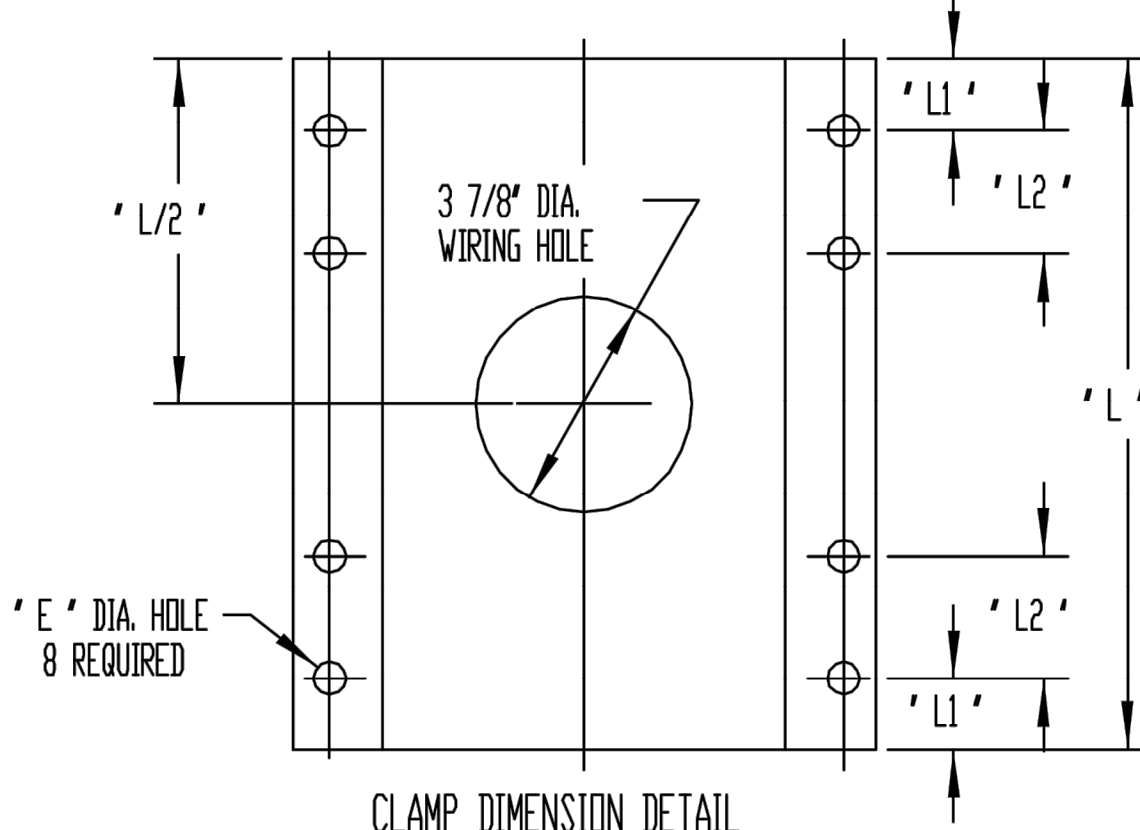
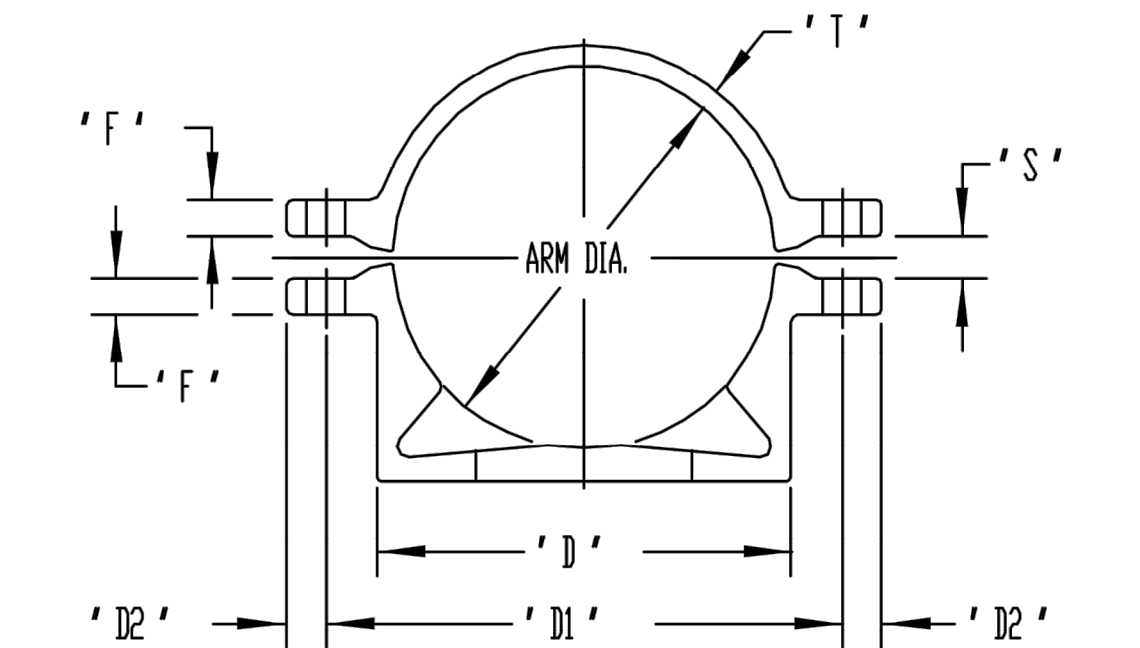

UNION COUNTY CODE NO.	ARM LENGTH	ARM SIZE 'D1' X 'W' WALL	ARM TAPER 'D1' X 'D2'	MATERIAL SIZE SUMMARY TABLE			BASE WELD SIZES	
				TOP CROSS-SECTION 'E1' X 'E2'	SHAFT SIZE 'S1' X 'T' WALL	SHAFT TAPER 'S1' X 'S2' X 'S1'	'W1'	'W2'
UC-SMA15-TB	15' - 0"	6 5/8" X .156 WALL	6 5/8" X 3"	9 1/2" X 5 7/8"	8" X .250 WALL	8" X 5 7/8" X 8"	5/16"	1/4"
UC-SMA20-TB	20' - 0"	8" X .156 WALL	8" X 4"	11" X 8"	10" X .188 WALL	10 X 8" X 10"	1/4"	3/16"
UC-SMA25-TB	25' - 0"	8" X .188 WALL	8" X 4"	11" X 8"	10" X .250 WALL	10" X 8" X 10"	5/16"	1/4"
UC-SMA30-TB	30' - 0"	10" X .156 WALL	10" X 5"	14 5/8" X 9"	12" X .250 WALL	12" X 9" X 12"	5/16"	1/4"
UC-SMA35-TB	35' - 0"	10" X .188 WALL	10" X 5"	14 5/8" X 9"	12" X .250 WALL	12" X 9" X 12"	5/16"	1/4"

ARM DIA.	'D'	'D1'	'D2'	'F'	'S'	'T'	'L'	'L1'	'L2'	'E'
6 5/8"	7 3/16"	8 5/8"	5/8"	5/8"	13/16"	3/8"	12"	1 11/16"	2 1/8"	11/16"
8"	8 7/8"	10 5/8"	5/8"	3/4"	3/4"	11/16"	14"	1 3/16"	1 15/16"	11/16"
10"	10 1/8"	12 1/8"	7/8"	1 1/4"	2"	5/8"	18"	1 1/4"	2 3/4"	13/16"

16' - 6" CENTER OF CLAMPS

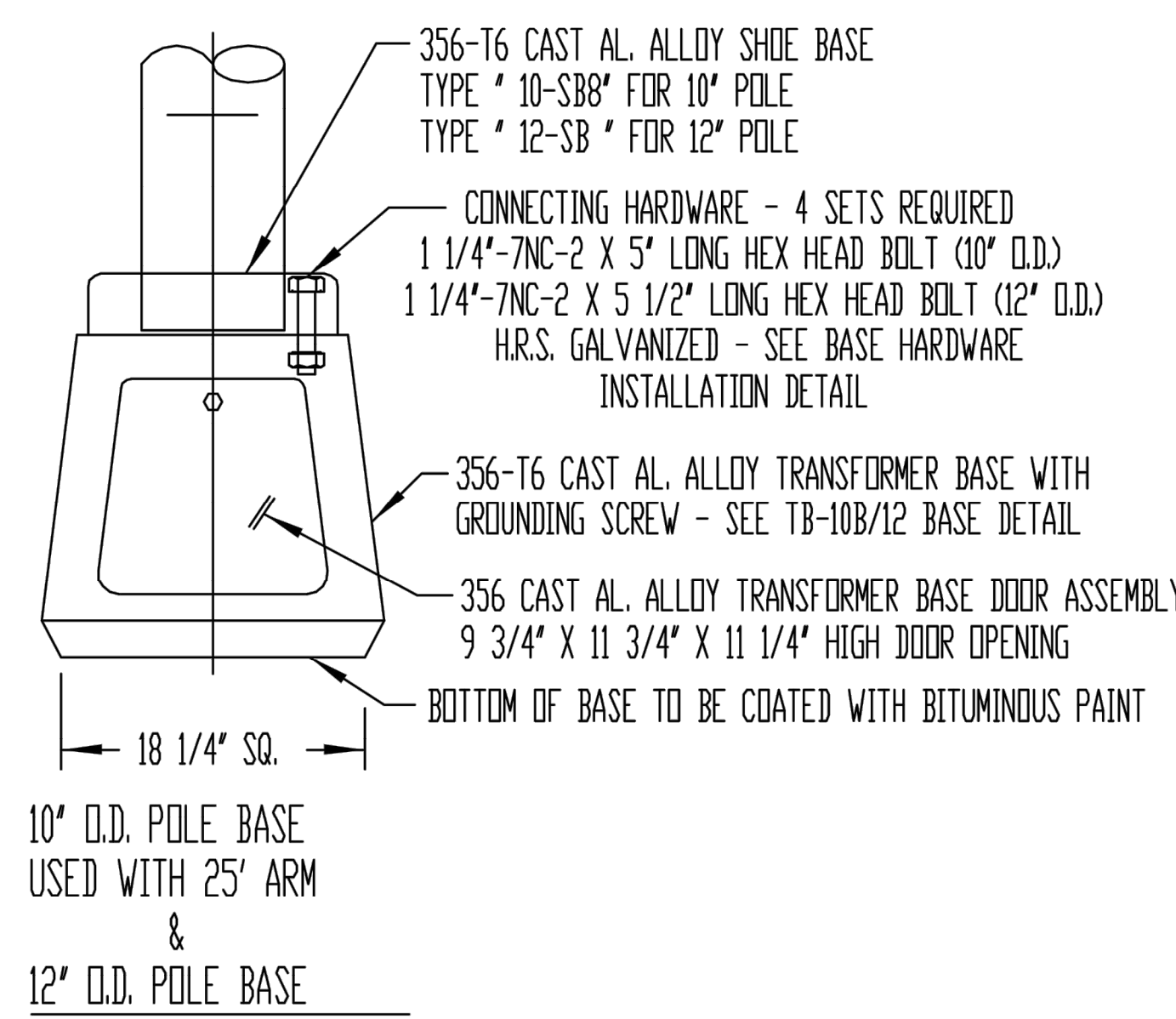
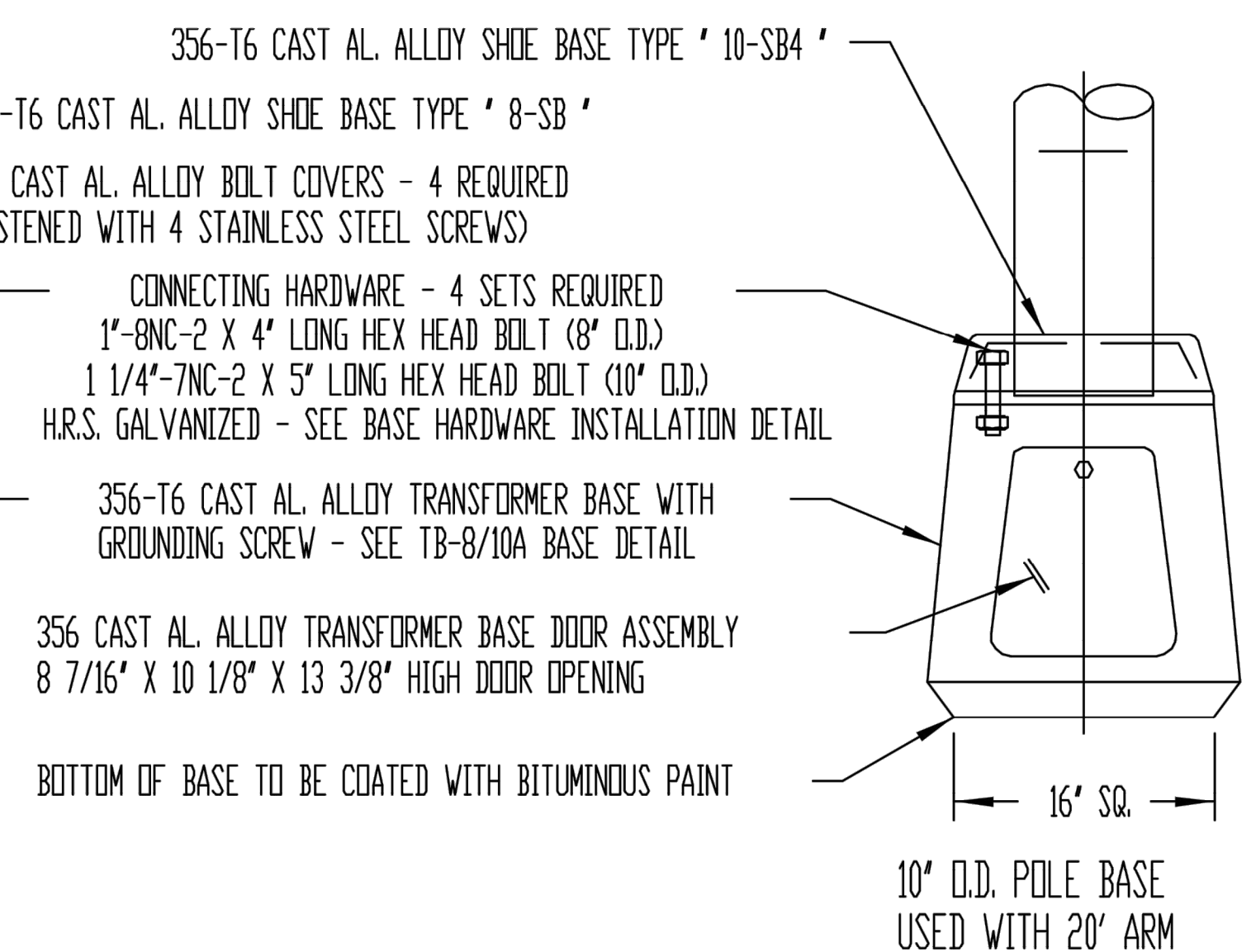
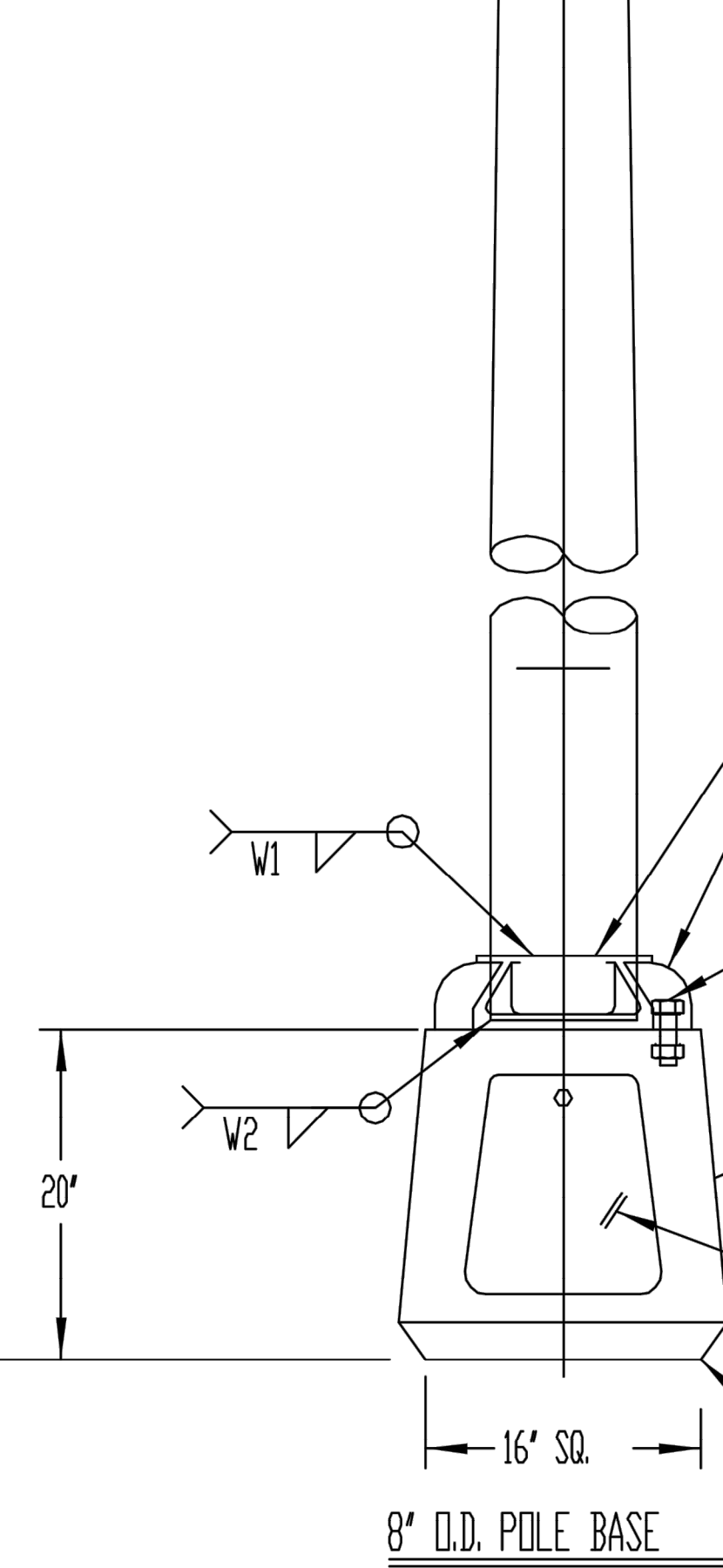

REVISION	BY	DATE
UNION COUNTY, DIVISION OF ENGINEERING		
ELECTRICAL DETAILS		
SINGLE MEMBER TRAFFIC STANDARDS		
COUNTY OF UNION 2325 SOUTH AVENUE SCOTCH PLAINS, NJ 07076		SHEET NO. 28 OF 31

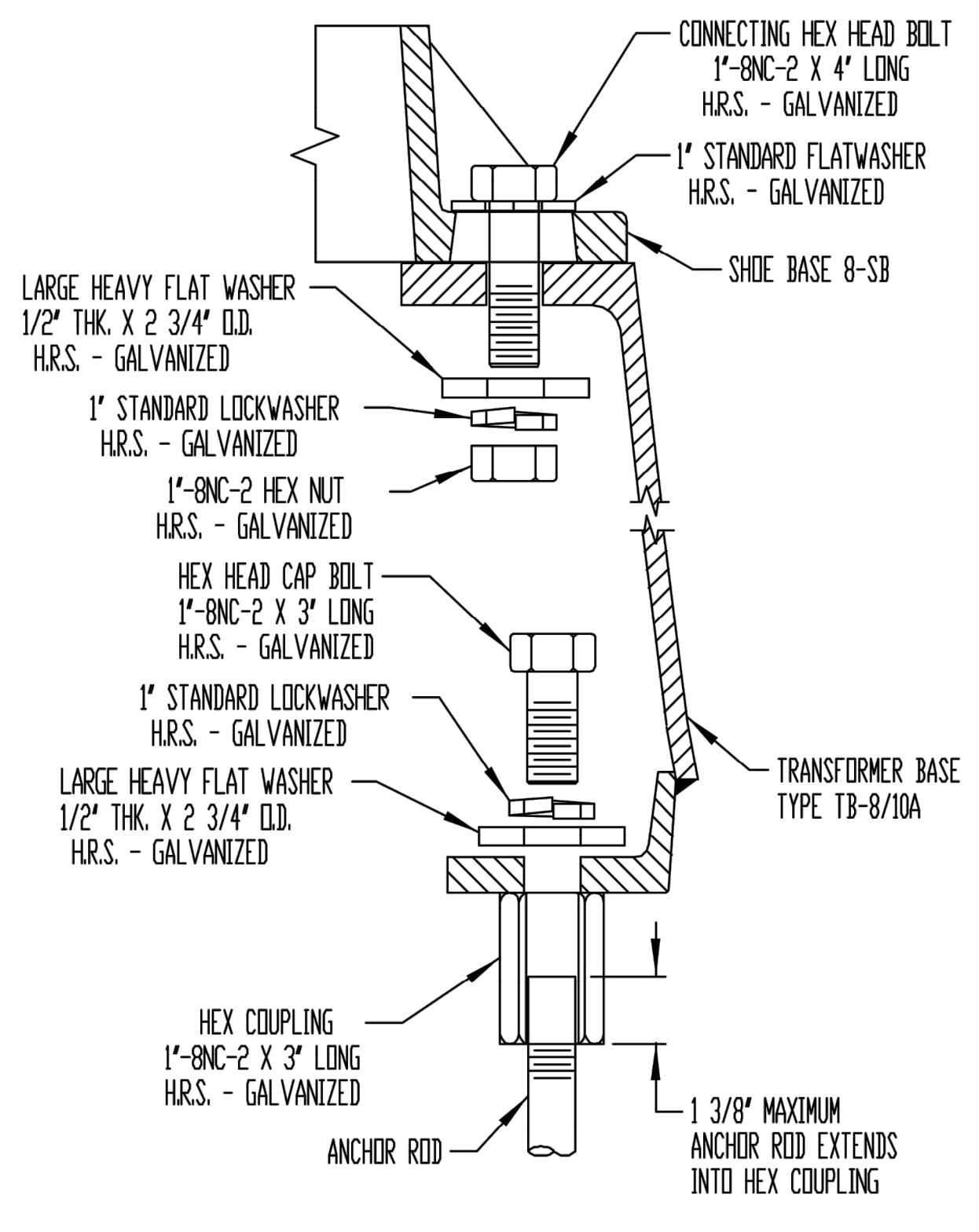
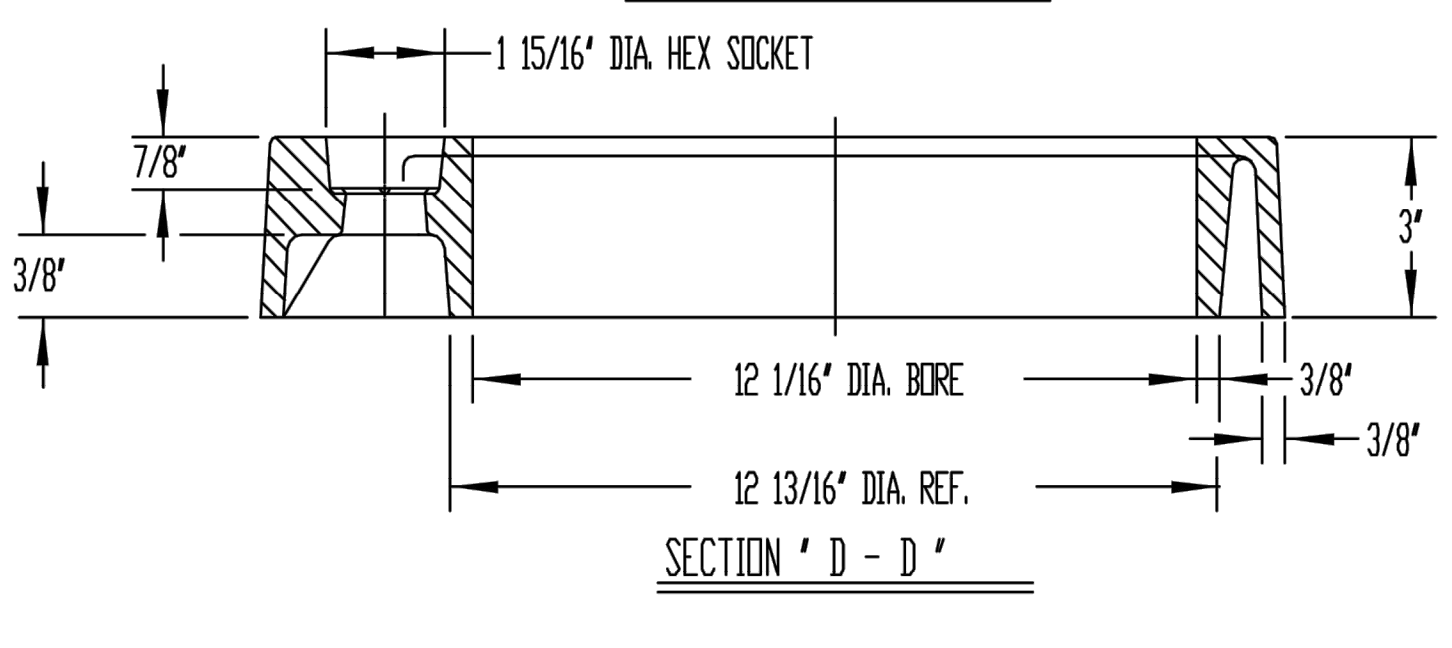
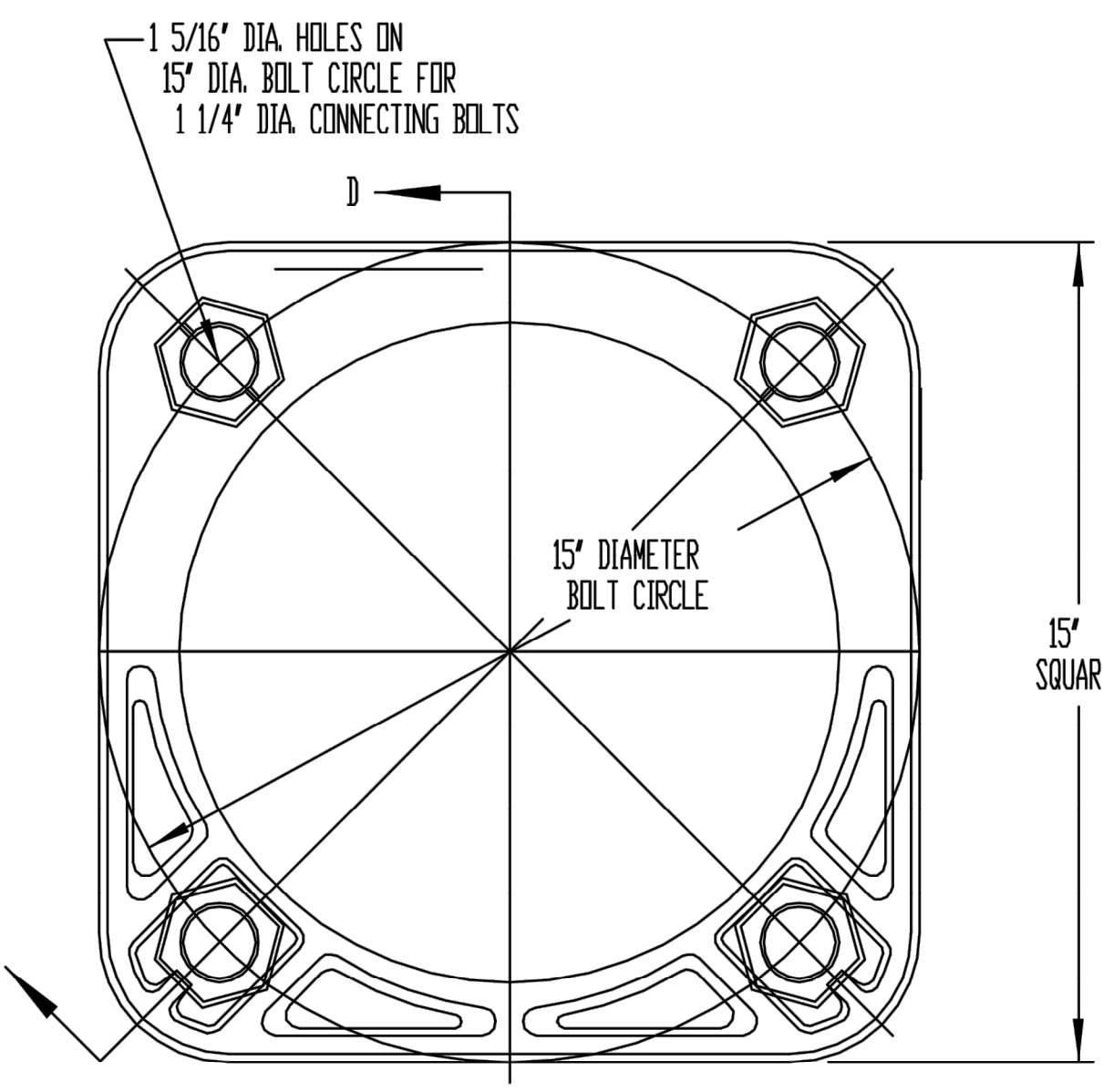
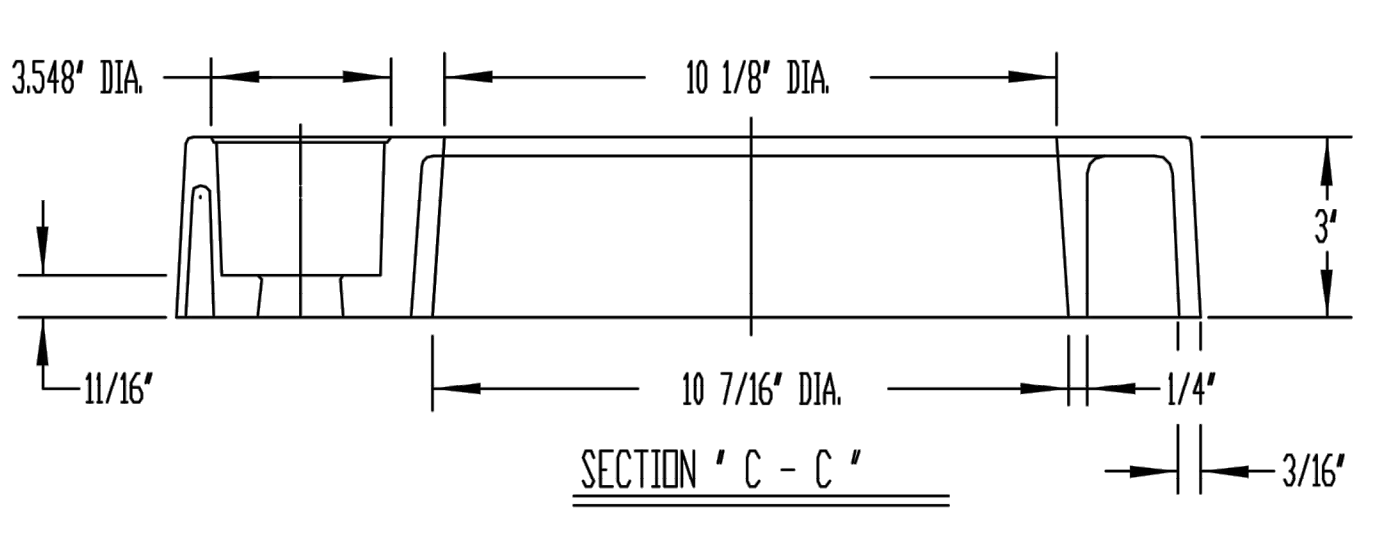
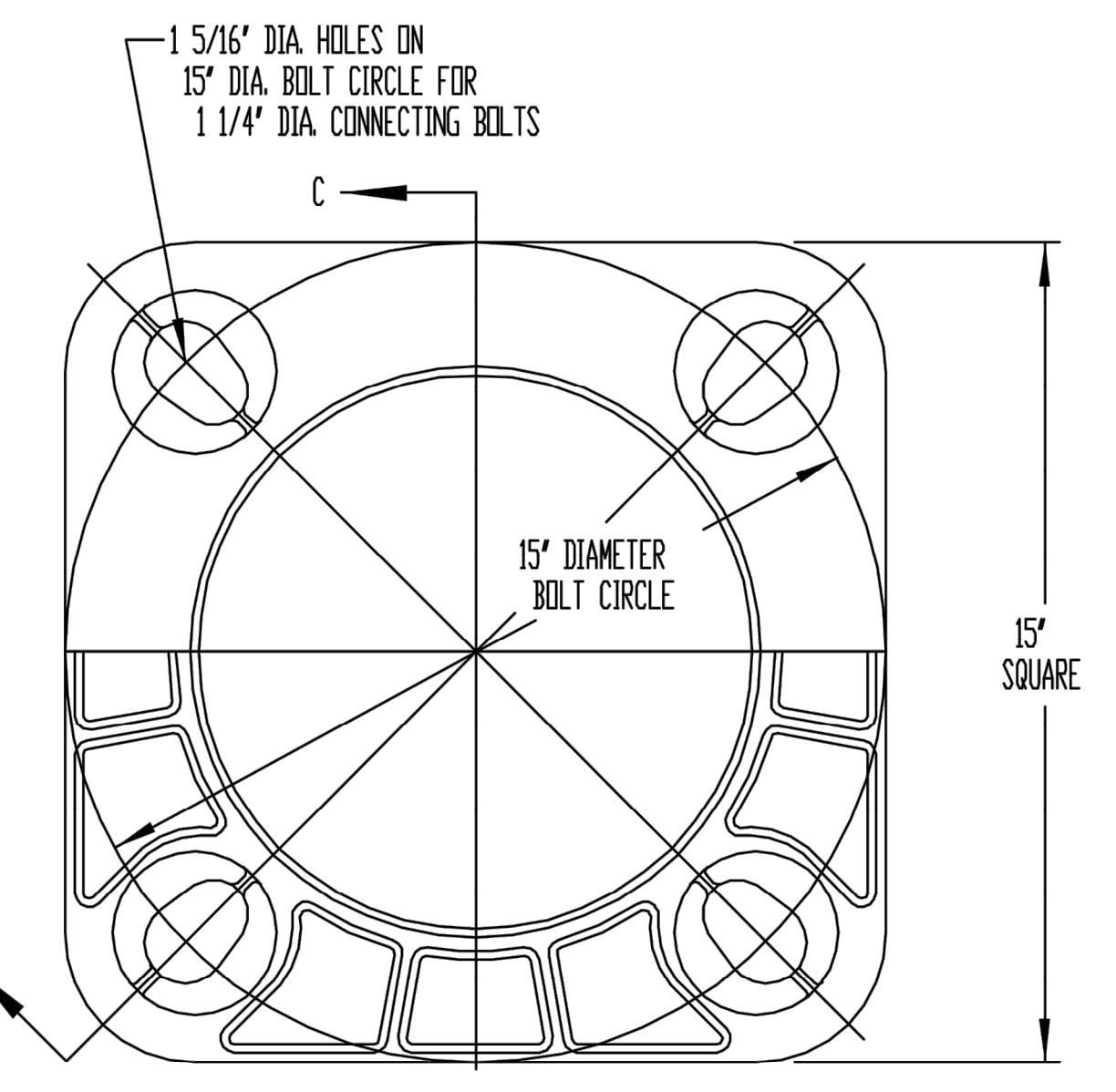
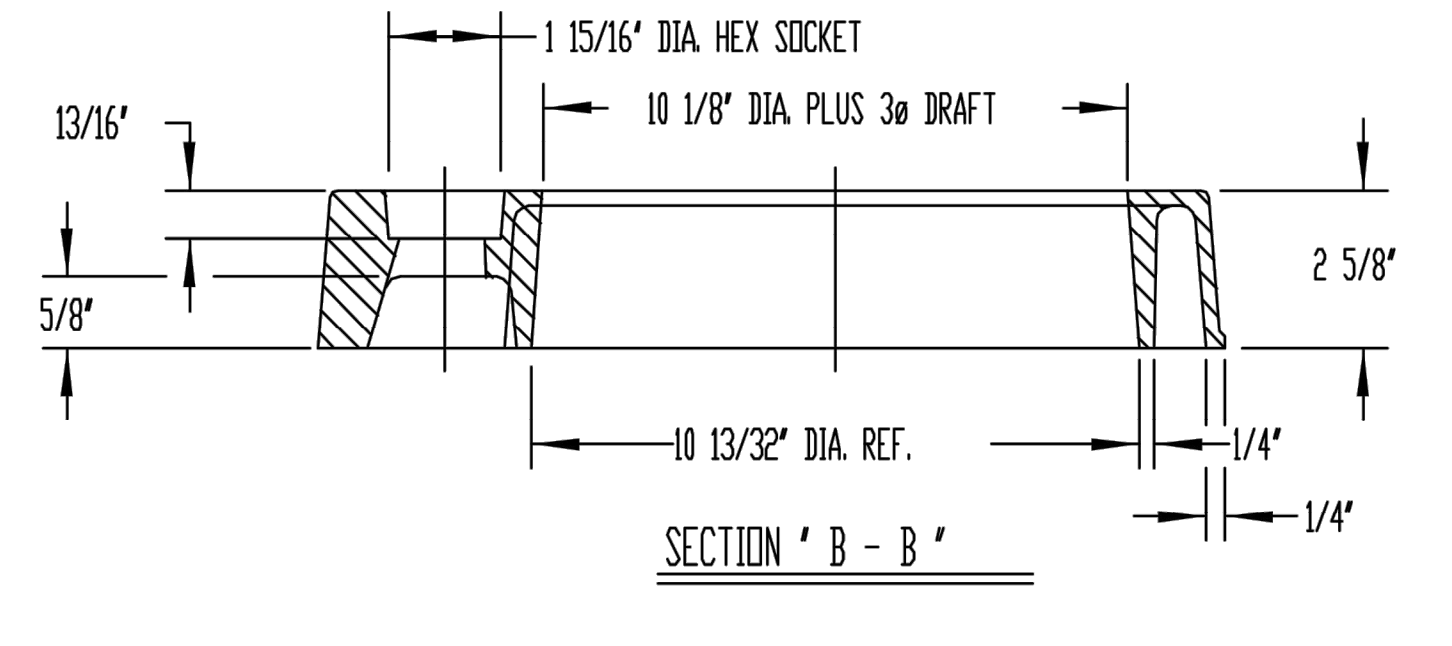
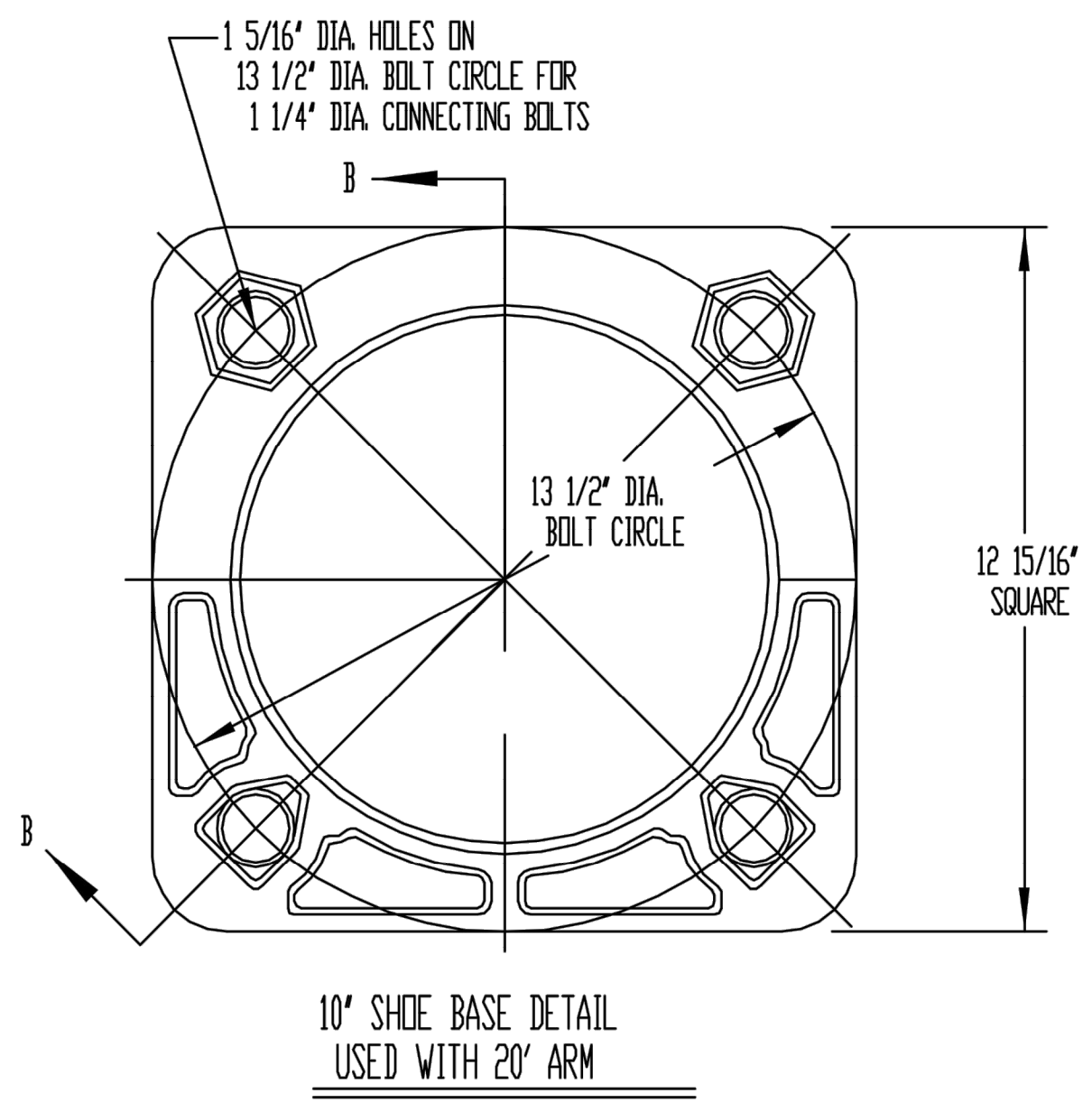
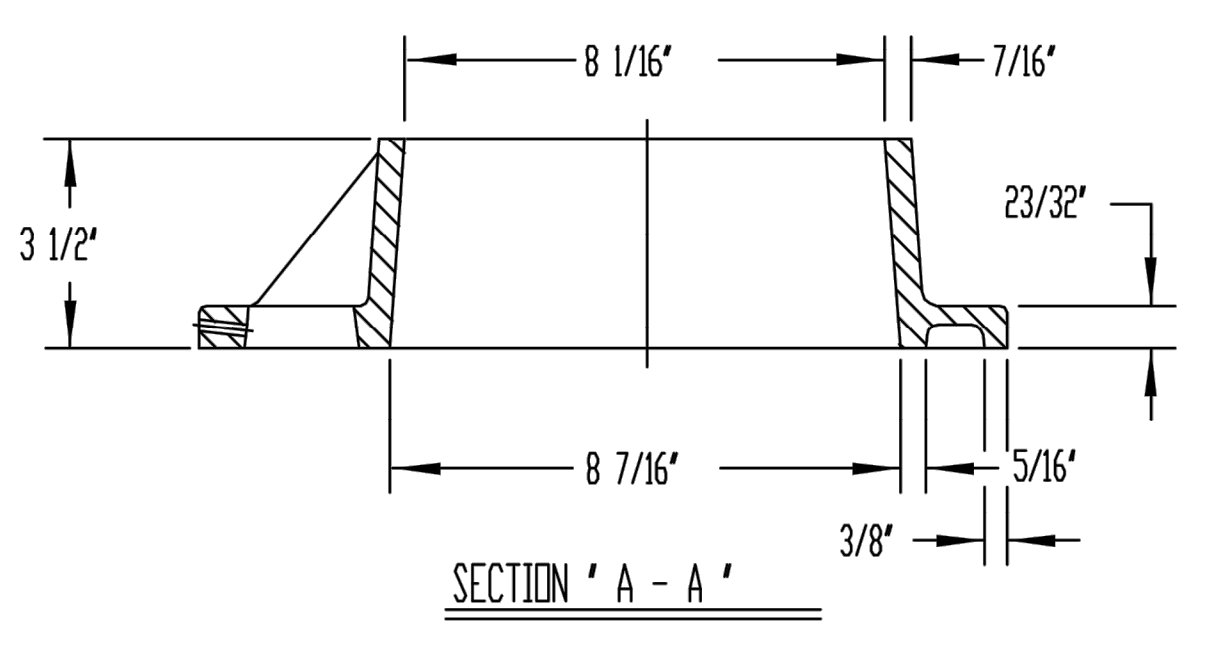
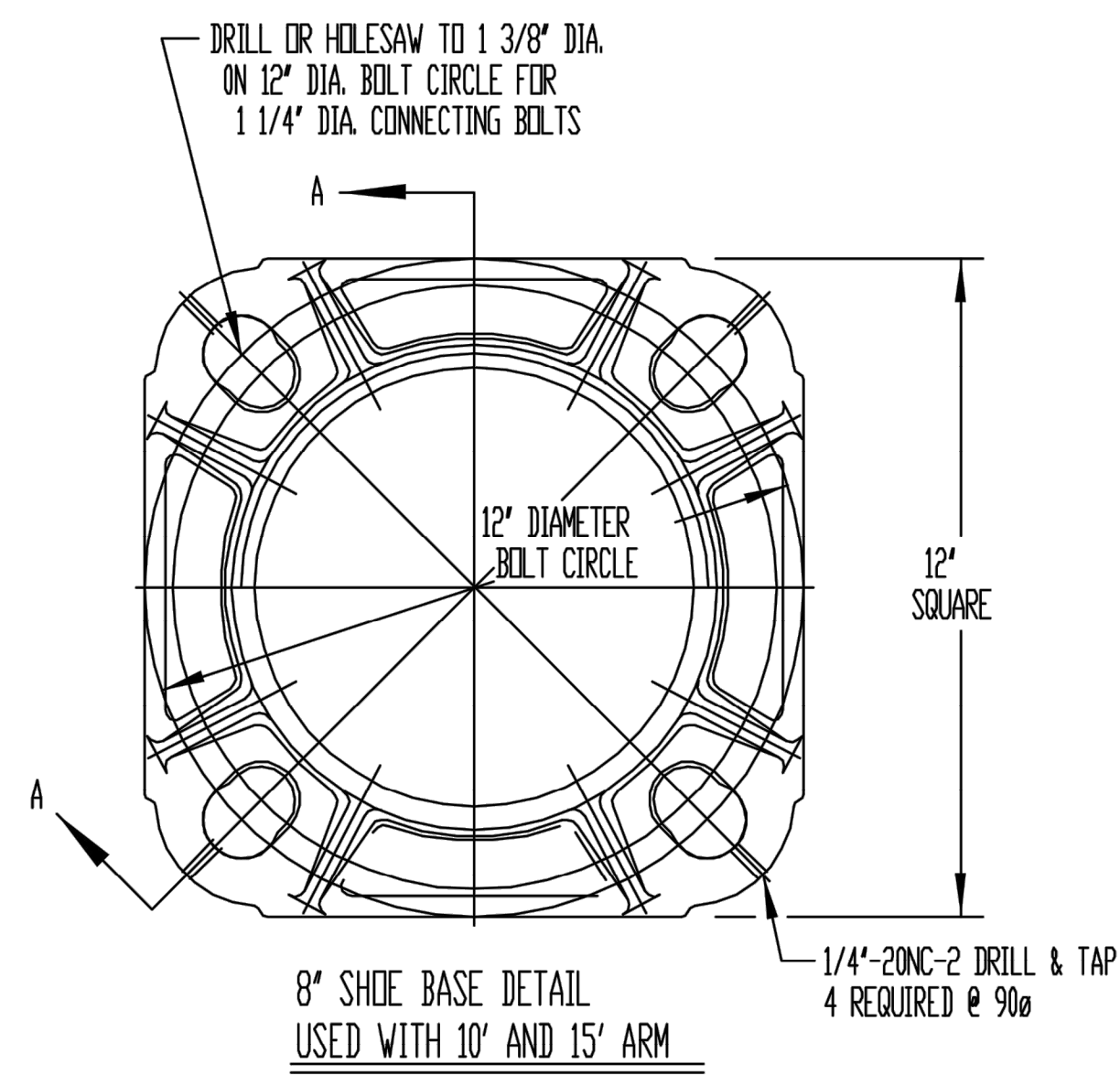

TRANSFORMER BASE HARDWARE INSTALLATION 8" O.D. SIGNAL POLE ASSEMBLY

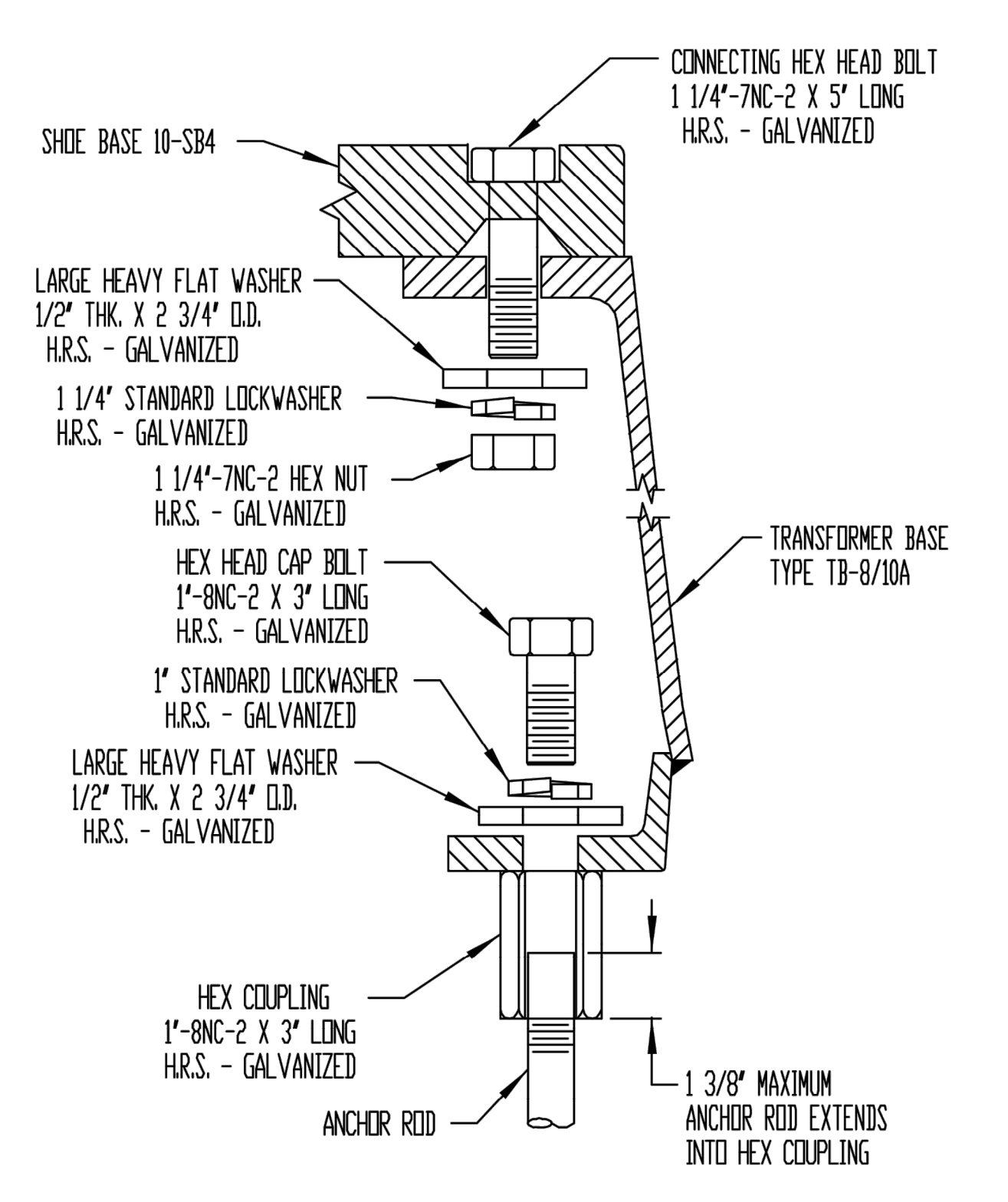

TRANSFORMER BASE HARDWARE INSTALLATION 10" O.D. SIGNAL POLE ASSEMBLY USED WITH 20' ARM

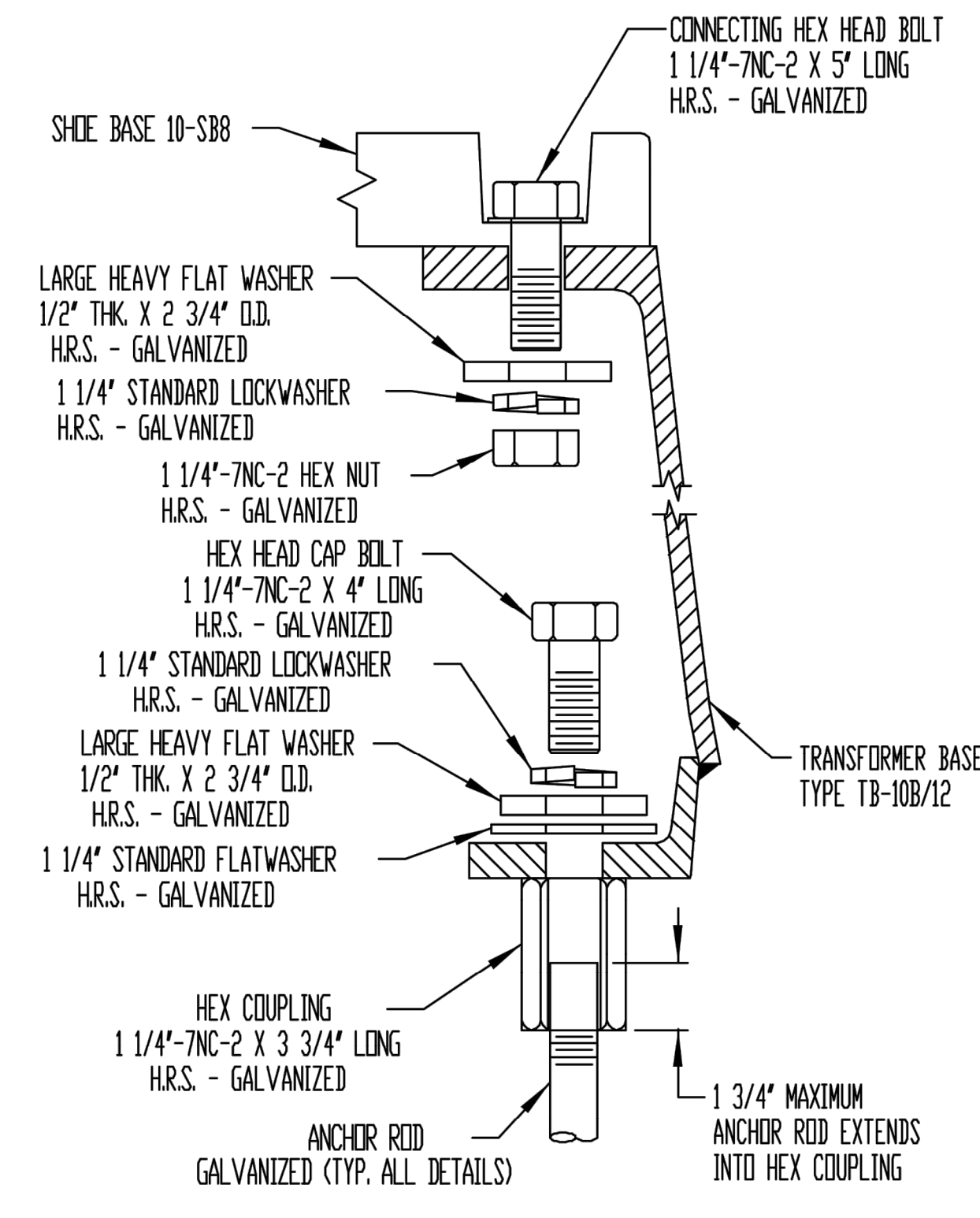

TRANSFORMER BASE HARDWARE INSTALLATION 10" O.D. SIGNAL POLE ASSEMBLY USED WITH 25' ARM

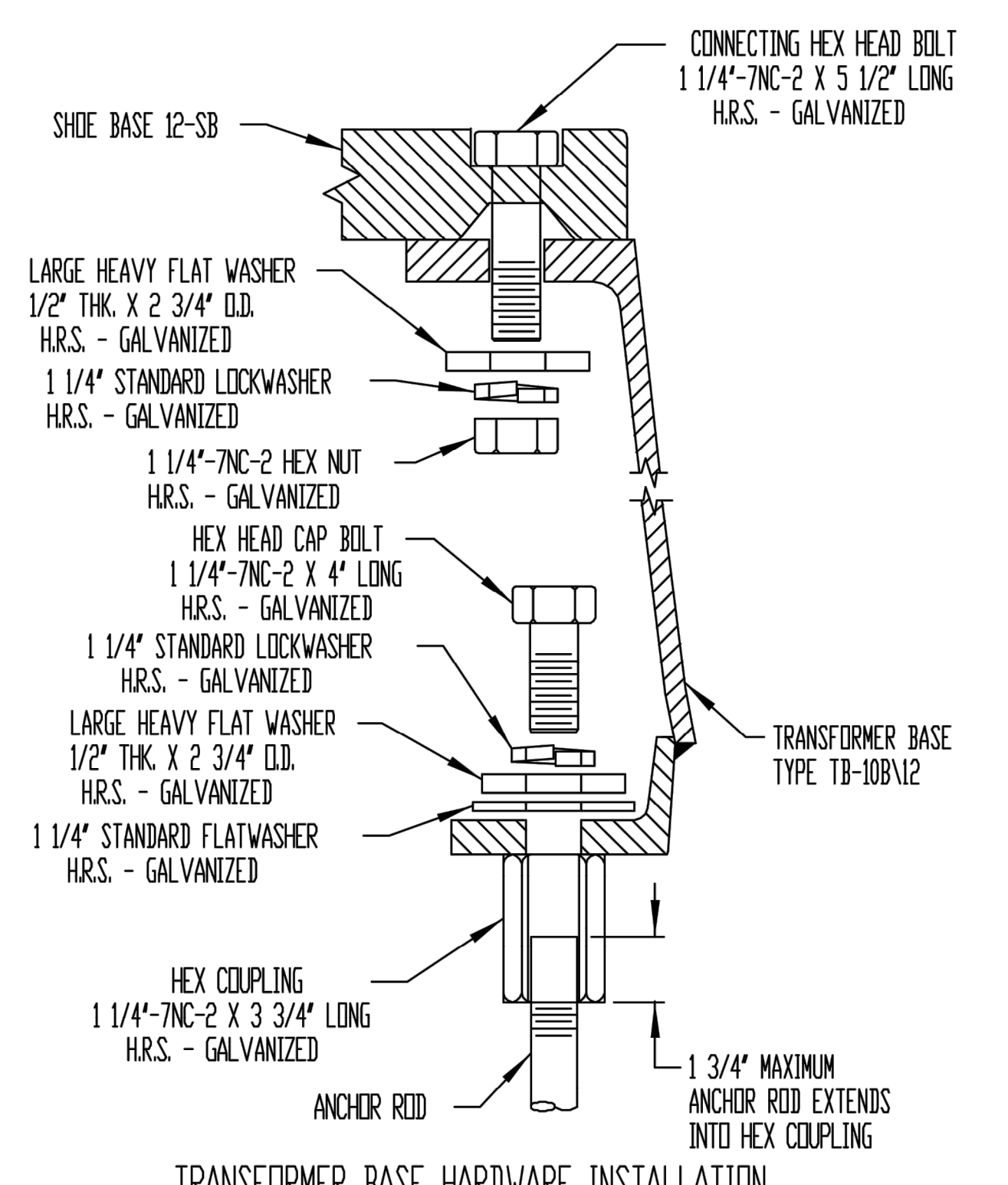

TRANSFORMER BASE HARDWARE INSTALLATION 12" O.D. SIGNAL POLE ASSEMBLY USED WITH 30' AND 35' ARM

THE LOUIS BERGER GROUP - Feb 10, 2014 - 12:58pm - CAD FILE: L:\TRANS\CP-2011\CCC 1283 Elizabeth Signs\CAD\DWGS\08 - Construction Details\020.dwg

REVISION	BY C'K'D	DATE
UNION COUNTY, DIVISION OF ENGINEERING		
ELECTRICAL DETAILS		
SINGLE MEMBER TRAFFIC STANDARDS		
COUNTY OF UNION 2325 SOUTH AVENUE SCOTCH PLAINS, NJ 07076		SHEET NO. 29 OF 31

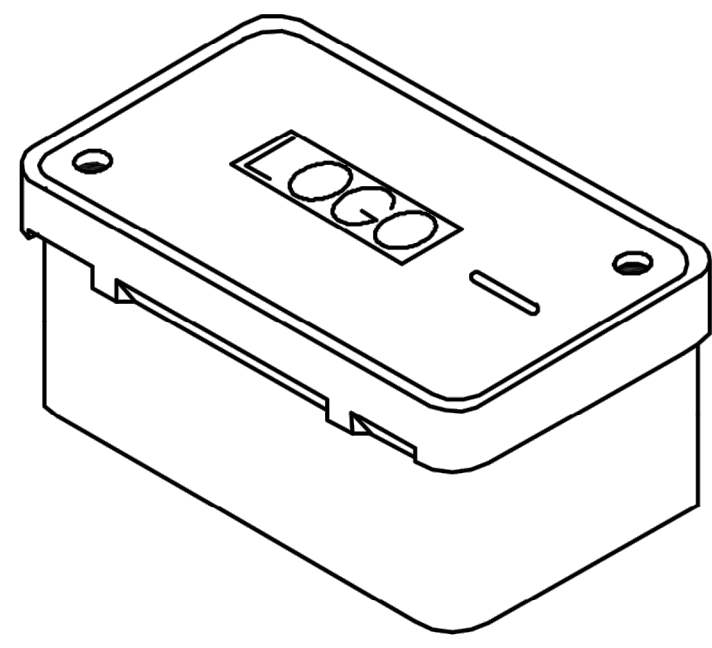

PG STYLE SPLICE BOX
(NO BASE)

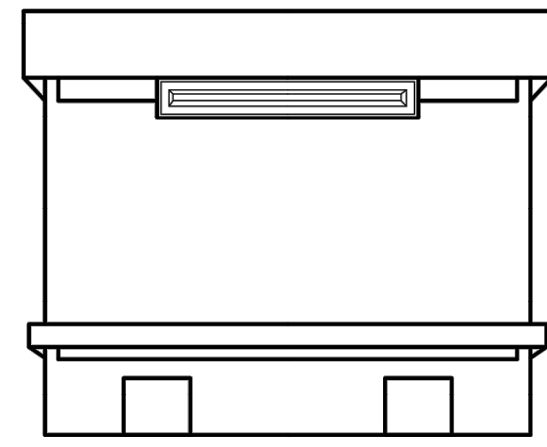

L BOX & EXTENSION SIDE VIEW
(NO BASE)

**PANEL VAULT & BOX
INSTALLATION PROCEDURE**

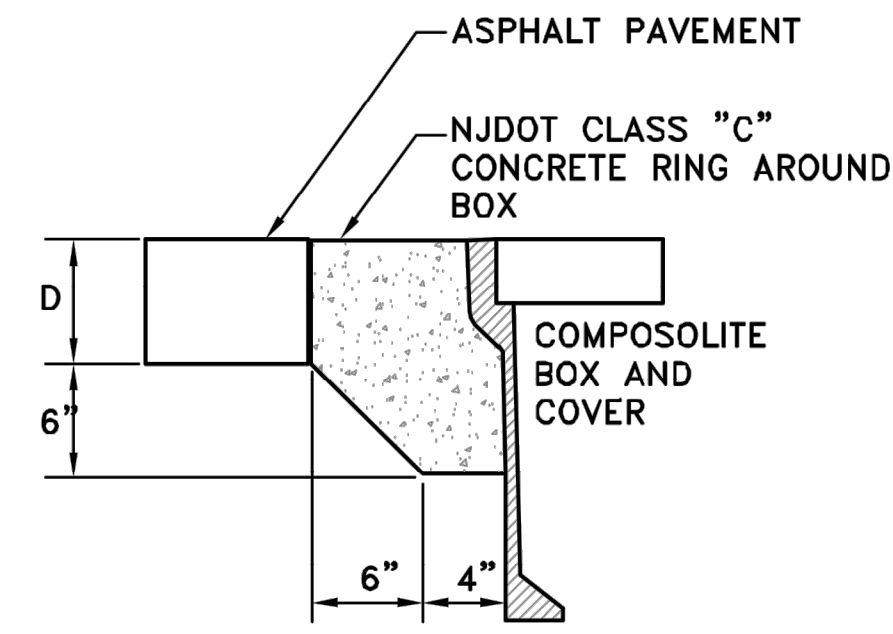

IN ASPHALT PAVEMENTS

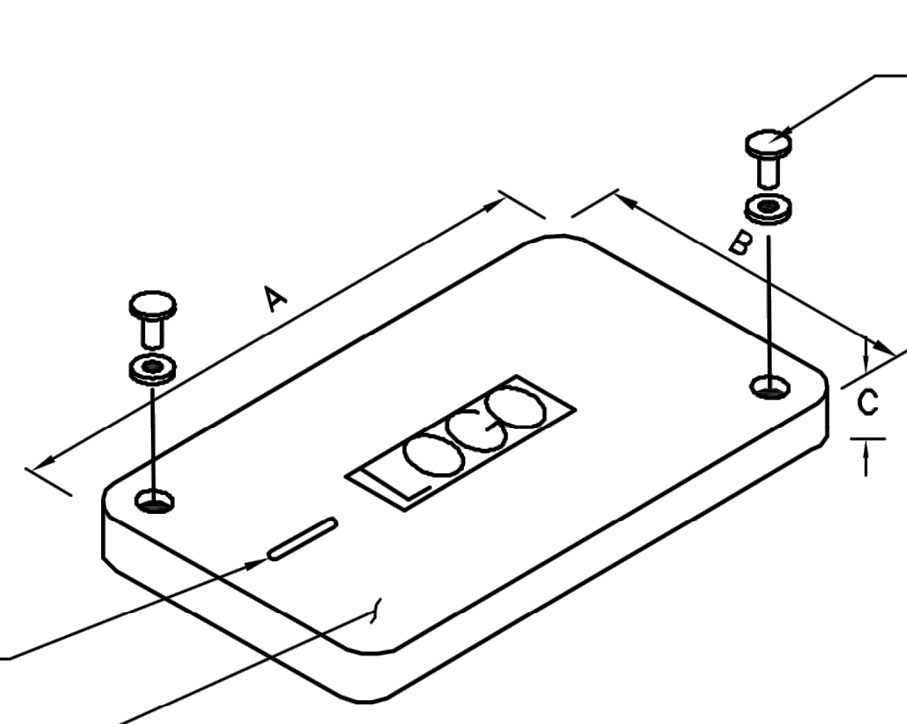

PULL SLOT
SKID RESISTANT SURFACE

COVER

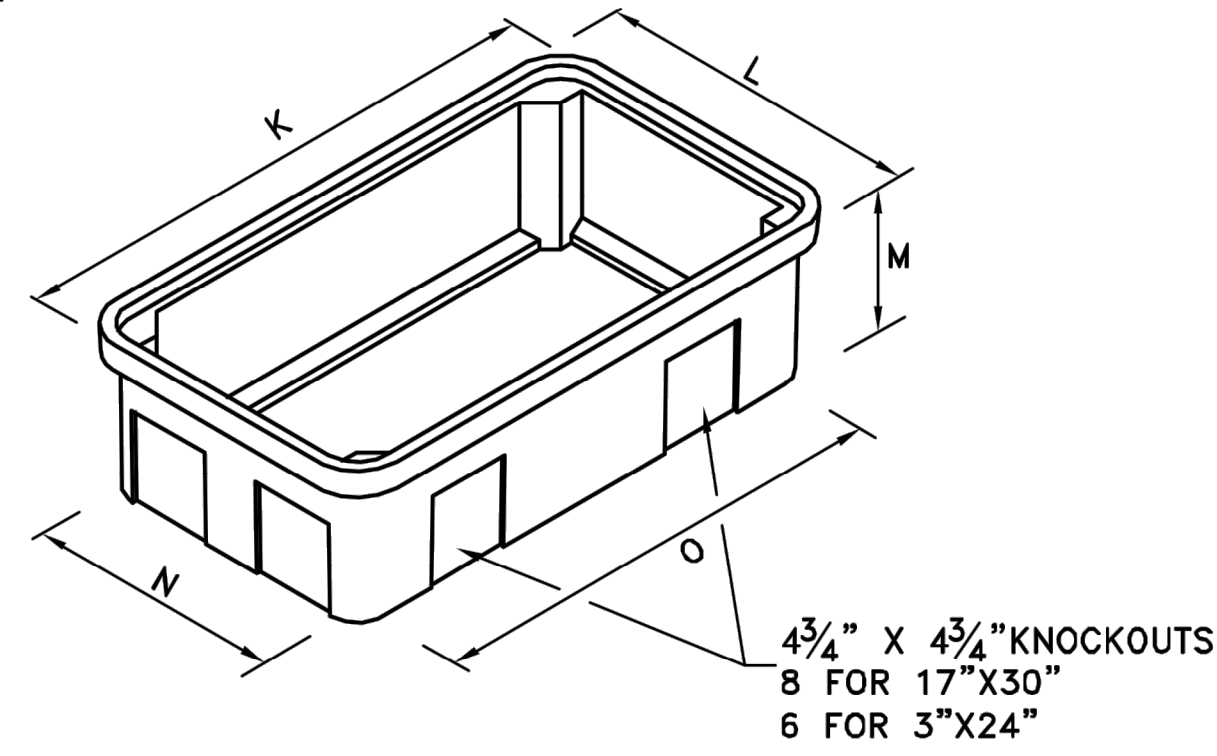

4 3/4" X 4 3/4" KNOCKOUTS
8 FOR 17"X30"
6 FOR 3"X24"

EXTENSION

NOTE: EXTENSION FOR USE UNDER BOX ONLY.

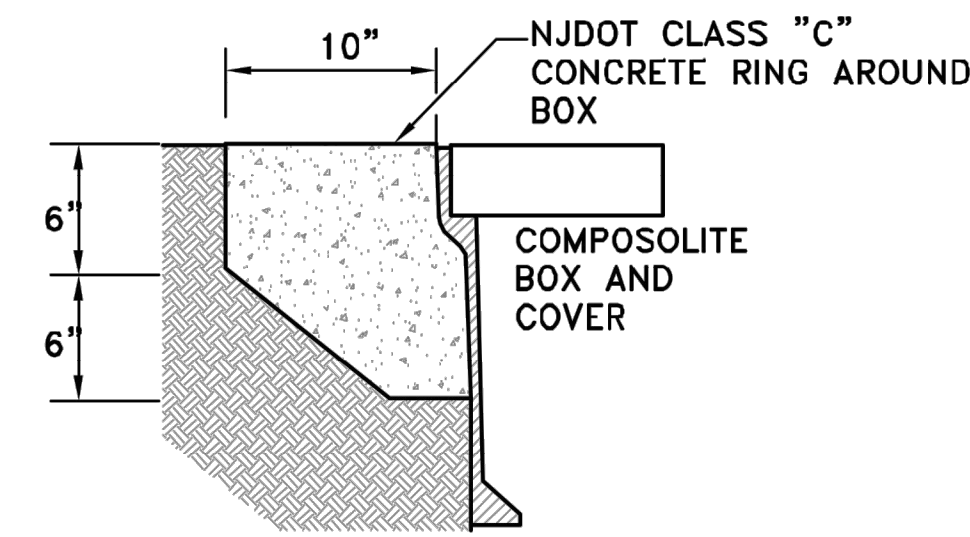

IN COMPACTED EARTH

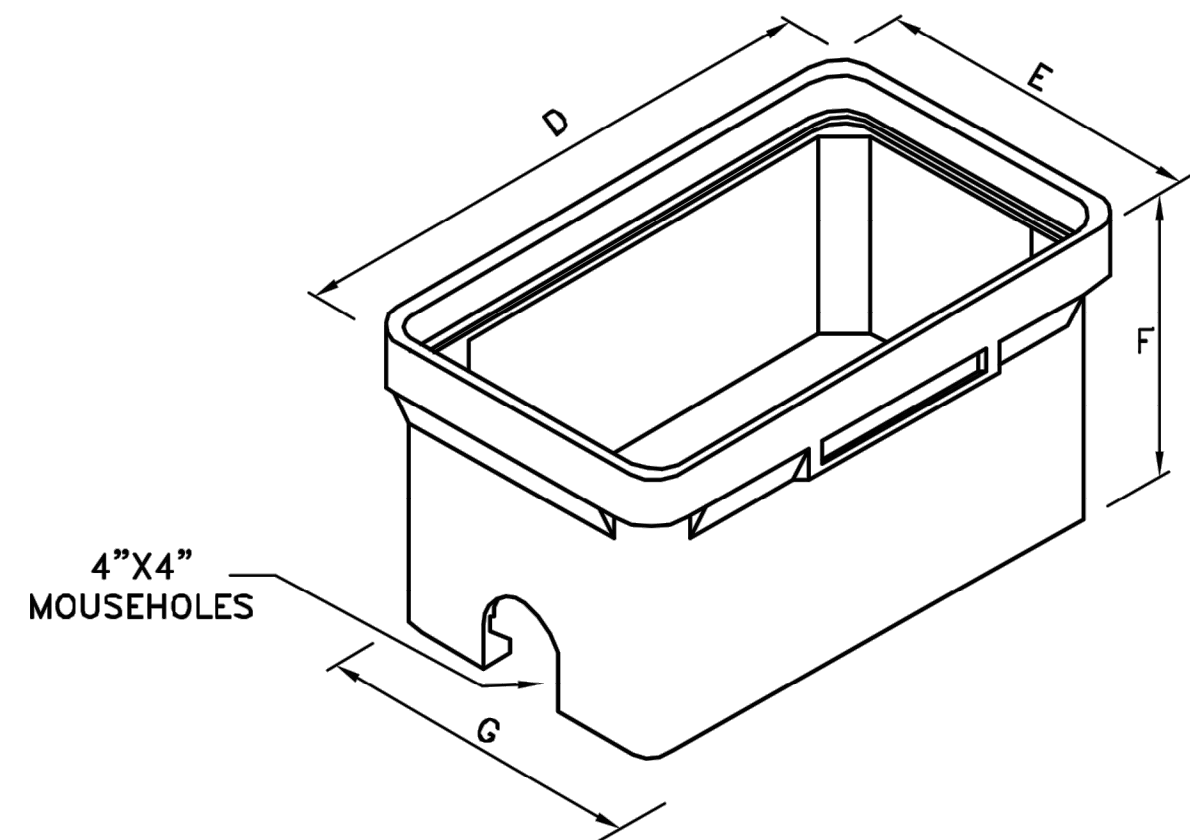

4"X4" MOUSEHOLES

SPLICE BOX DIMENSIONS

LOGO FOR COVER SHALL BE "TRAFFIC SIGNAL"
REFER TO THE PLANS AND SPECIFICATIONS
FOR REQUIRED COVER COLORS.

BOXES (STACKABLE)

SIZE	DIMENSION (IN INCHES)										
	A	B	C	D	E	F	G	H	I	J	
13"X24"	23 1/4"	13 3/4"	2	25	15 1/2"	18	11 3/4"	21 1/4"	1 1/2"	16	
17"X30"	30 1/2"	17 1/2"	2	32 1/4"	19 1/4"	24	15 1/2"	28 1/2"	1 1/4"	22	
24"X36"	35 5/8"	24	3	37 5/8"	26	24	22 1/4"	33 7/8"	2	21	

EXTENSIONS

SIZE	DIMENSION (IN INCHES)							
	K	L	M	N	O	P	Q	
13"X24"	23 3/4"	14 1/4"	8 3/4"	11 3/4"	21 1/4"	8	1	
17"X30"	30 7/8"	17 7/8"	8 3/4"	15 3/8"	28 3/8"	8	1	
24"X36"	37 1/8"	25 1/2"	8 3/4"	21 3/4"	33 1/2"	8	1	

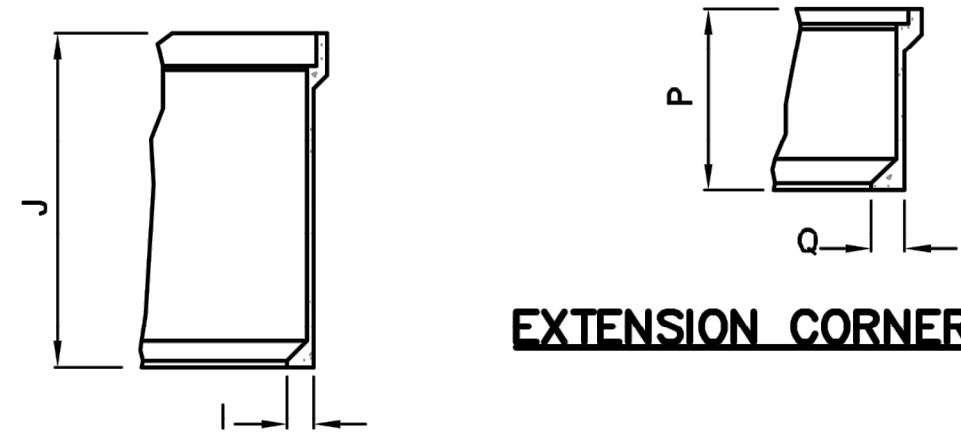

SPLICE BOX CORNER DETAIL

EXTENSION CORNER DETAIL

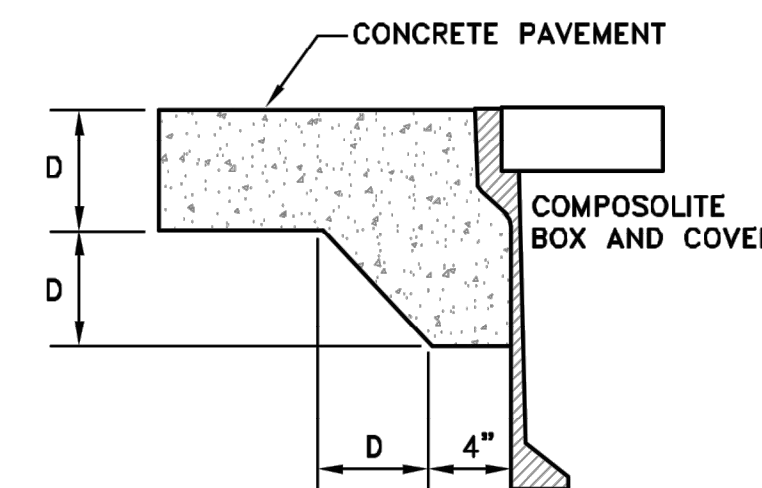

IN CONCRETE PAVEMENTS

ALL BOXES SHALL BE SET FLUSH WITH
SIDEWALK OR GRASS

NOTES:

1. CONCRETE ENCASEMENT TO BE NJDOT CLASS "C" OR BETTER.
2. CONCRETE ENCASEMENT RING DIMENSION, D, TO BE EQUAL TO DESIGN PAVEMENT DEPTH.
3. PAVEMENT AND SUBGRADE TO BE AS SHOWN ON THE ENGINEERING PLANS.
4. QUAZNE DOES NOT RECOMMEND THE USE OF CONCRETE OR POLYMER CONCRETE BOXES IN HIGH VOLUME TRAFFIC APPLICATIONS.
5. 3/4" GRAVEL OR OTHER SUITABLE MATERIAL TO BE PLACED AT THE BOTTOM OF BOX.
6. ALL COVERS SHALL BE HEAVY DUTY (15 KIPS OVER A 10 IN. SQ. MIN. TEST LOAD).
7. HOLES MADE IN THE SPLICE BOX OR EXTENSION WALLS TO ACCOMMODATE THE VARIOUS SIZE CONDUITS SHALL BE MADE USING A 68 KNOCKOUT PUNCH DRIVER OR MASONRY HOLE SAW. CABLE RACKS AND HOOKS SHALL BE PROVIDED FOR 17"X30" AND 24"X36" SPLICE BOXES (4 REQUIRED).

REVISION	BY	CHECKED	DATE
UNION COUNTY, DIVISION OF ENGINEERING			
ELECTRICAL DETAILS SPLICE BOX			
COUNTY OF UNION 2325 SOUTH AVENUE SCOTCH PLAINS, NJ 07076			SHEET NO. 30 OF 31

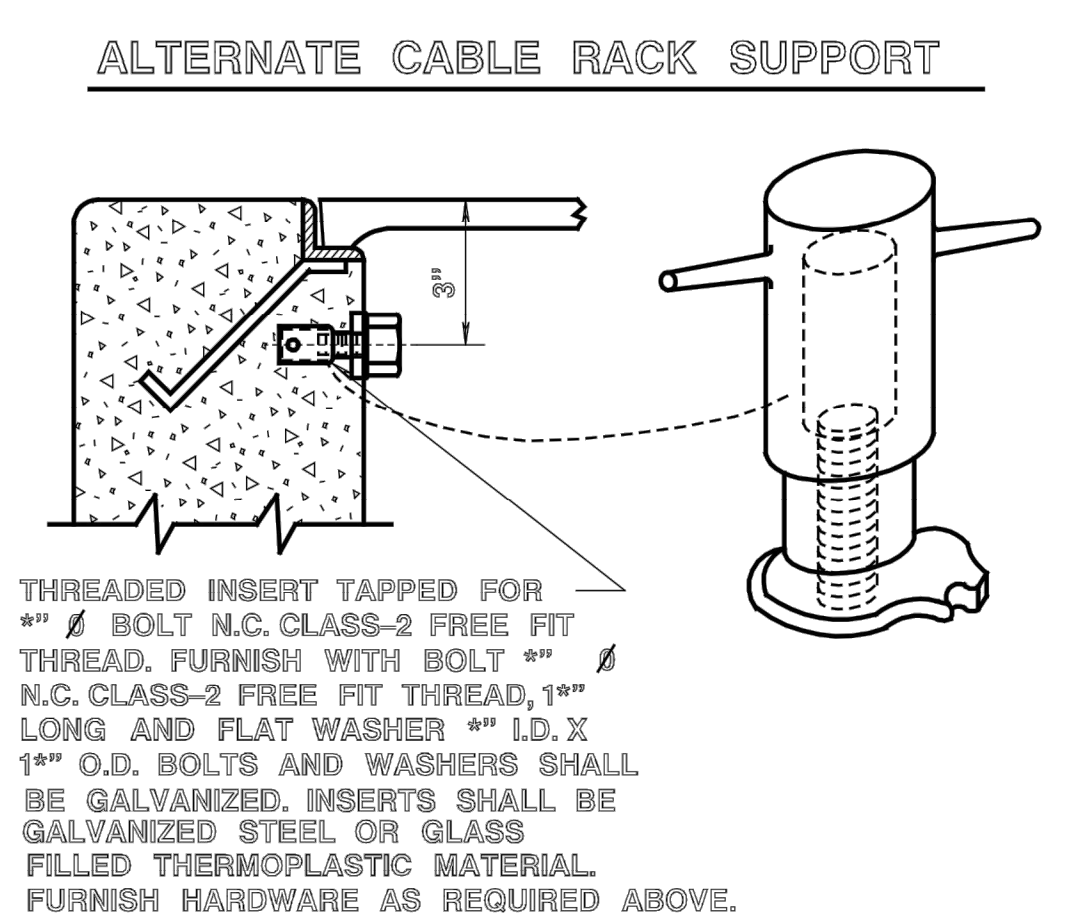
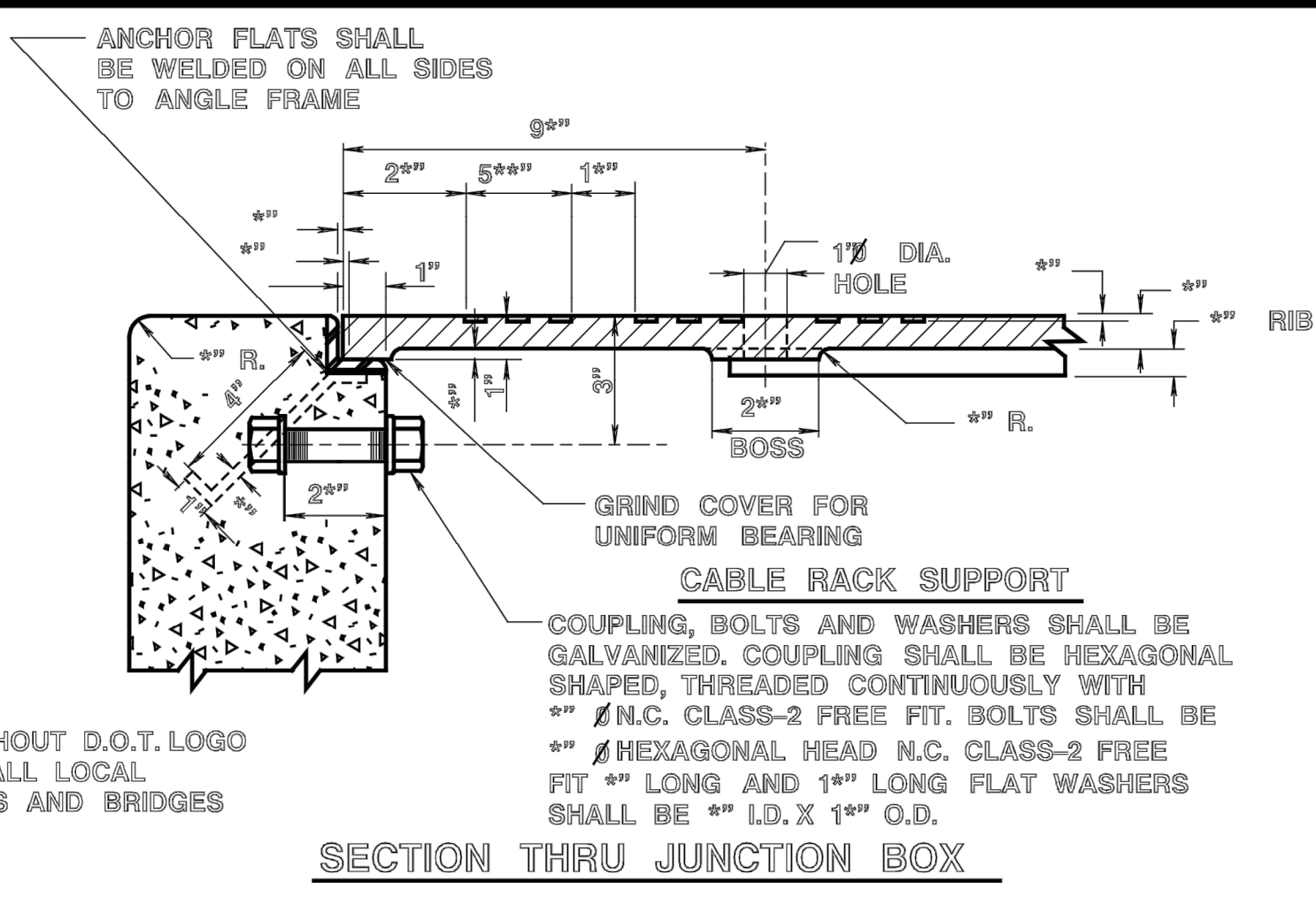
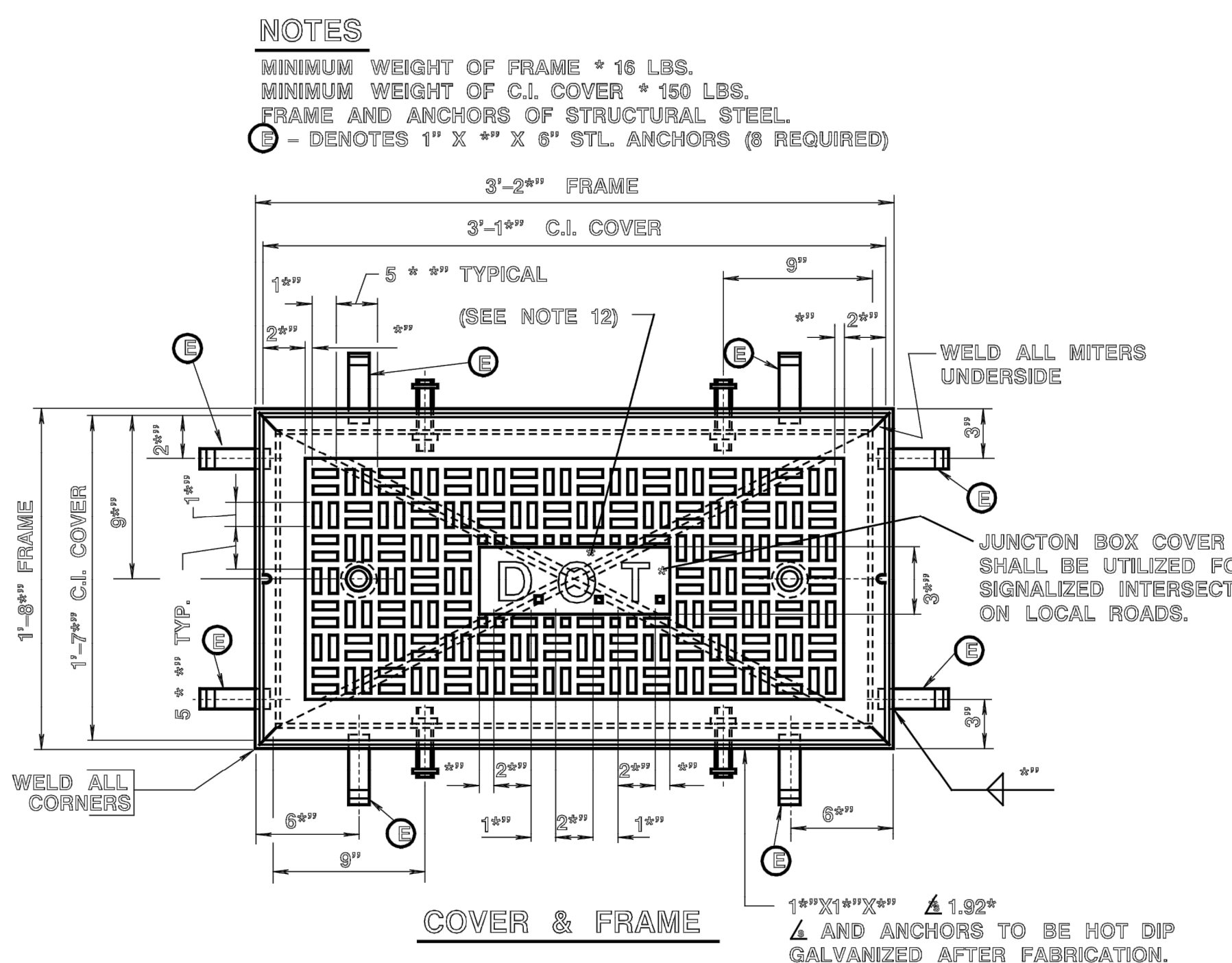
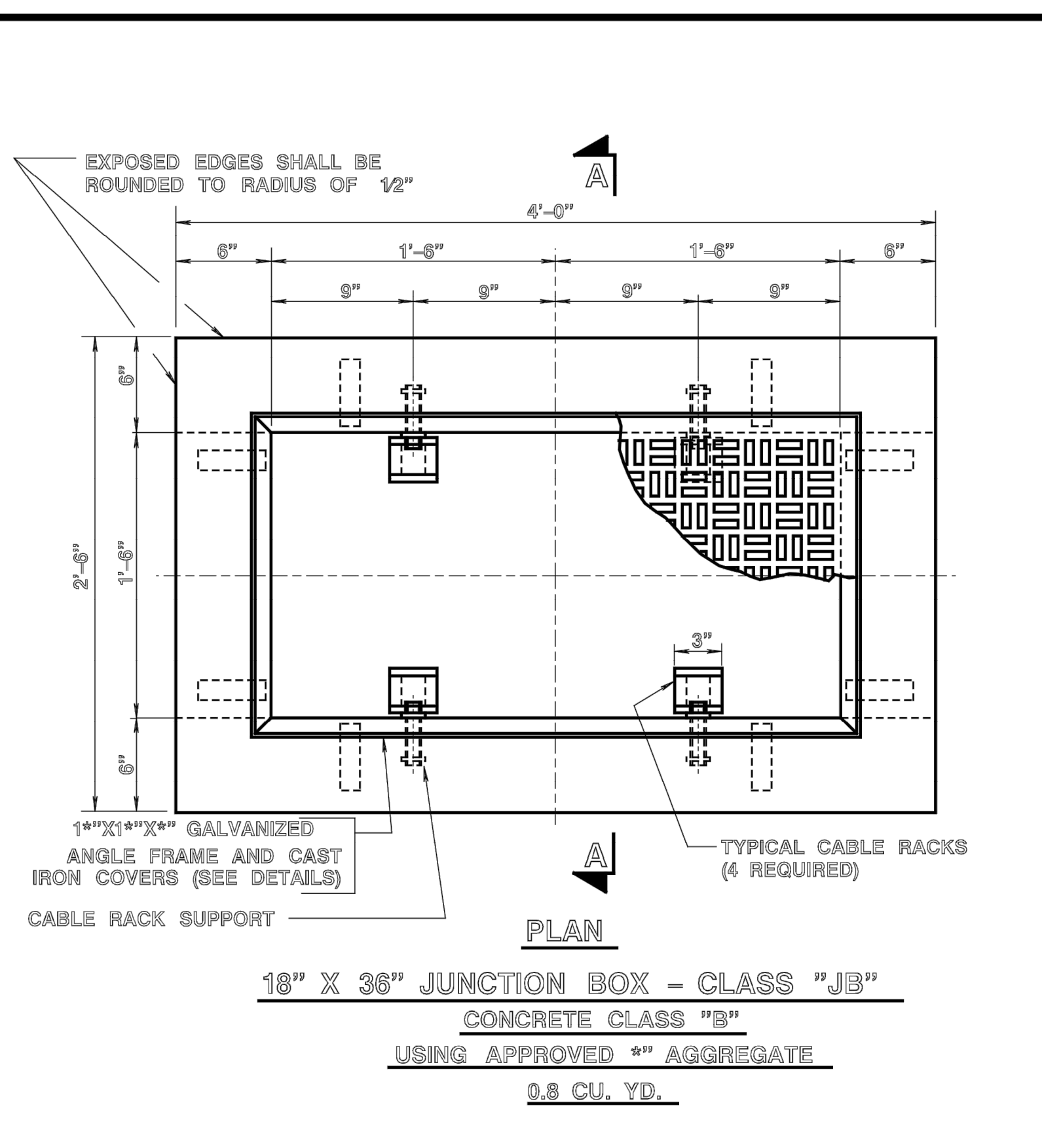

NOTE: JUNCTION BOX LOGO SHALL BE "TRAFFIC SIGNAL".

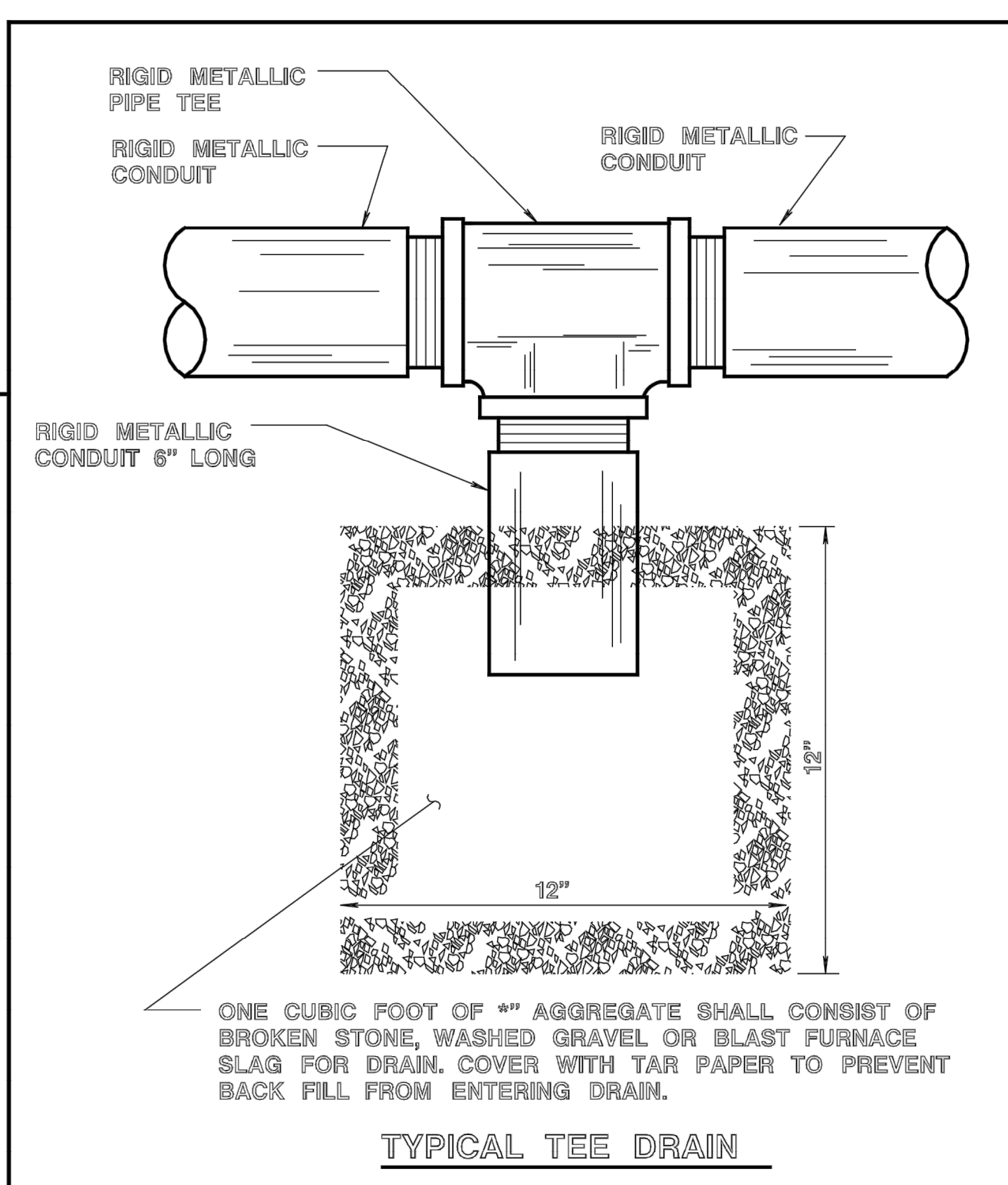

- NOTES:**
- JUNCTION BOX FOUNDATION SHALL BE SET PARALLEL TO THE CURB AND TOP OF JUNCTION BOX SHALL BE SET AT GRADE IN SIDEWALK, PAVED AREA, IN GRASS OR DIRT AREAS.
 - CABLE RACKS FURNISHED AND INSTALLED AS INDICATED.
 - BONDING AND GROUNDING INSULATED BUSHINGS SHALL BE INSTALLED ON METALLIC CONDUITS TERMINATING IN JUNCTION BOXES AND/OR FOUNDATIONS AND SHALL HAVE A FITTING TO PREVENT ENTRY OF FOREIGN MATTER PRIOR TO INSTALLATION OF WIRING.
 - A NYLON CORD, 125 POUND MINIMUM TEST STRENGTH, SHALL BE FURNISHED AND INSTALLED IN ALL CONDUITS. SEE SPECIFICATIONS.
 - CONDUITS SHALL ENTER JUNCTION BOX PERPENDICULAR TO WALLS OR AS APPROVED BY THE ENGINEER. A 2" SEPARATION SHALL BE MAINTAINED BETWEEN ADJACENT WALLS, CONDUITS, AND CABLE RACK LOCATIONS.
 - TERMINAL ENDS OF ALL METALLIC CONDUIT SHALL BE THREADED.
 - ALL NON-METALLIC CONDUITS SHALL TERMINATE WITH BELL END CONSTRUCTION IN JUNCTION BOX.
 - ALL UNUSED CONDUITS SHALL BE PLUGGED OR CAPPED.
 - ENGINEER MAY REQUIRE TOP OF JUNCTION BOX TO BE INCLINED IN ORDER TO CONFORM WITH FIELD CONDITIONS. JUNCTION BOX SHALL BE SET TO GRADE IN SIDEWALK AREA AND IN ALL OTHER AREAS.
 - WARNING TAPE SHALL BE A RED 4 MIL FLEXIBLE POLYETHYLENE FILM WHICH IS RESISTANT TO ACIDS, BASES, HYDROCARBONS AND WATER.
 - IN INCLINE AREA, NO PART OF THE JUNCTION BOX SHALL EXTEND MORE THAN 4" ABOVE THE FINISH GRADE.
 - JUNCTION BOX COVER WITHOUT D.O.T. LOGO SHALL BE UTILIZED FOR ALL LOCAL SIGNALIZED INTERSECTIONS AND BRIDGES ON LOCAL ROADS.

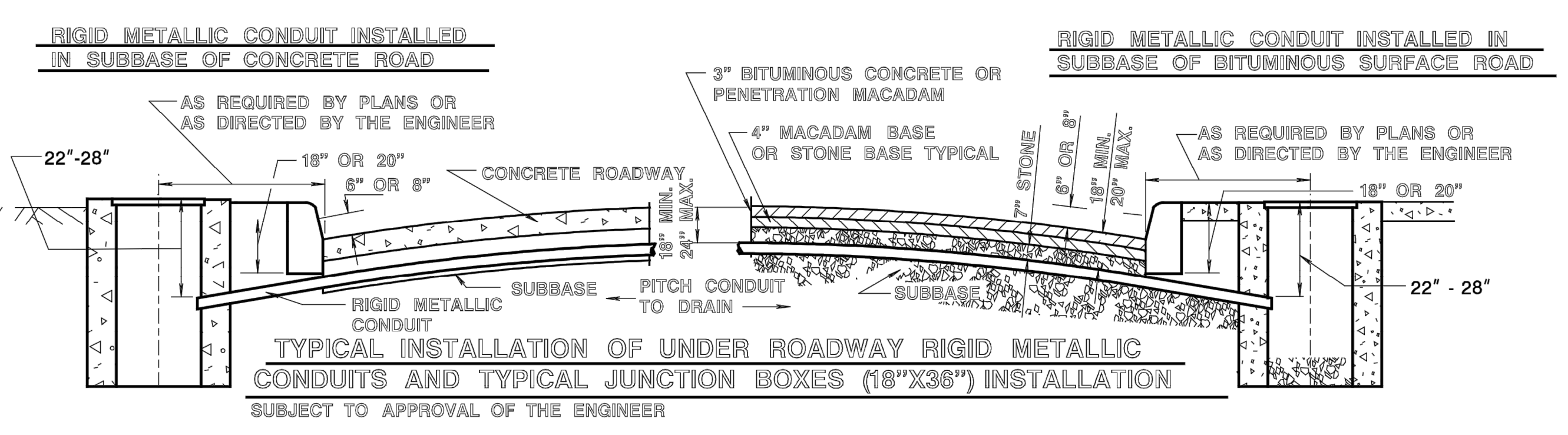
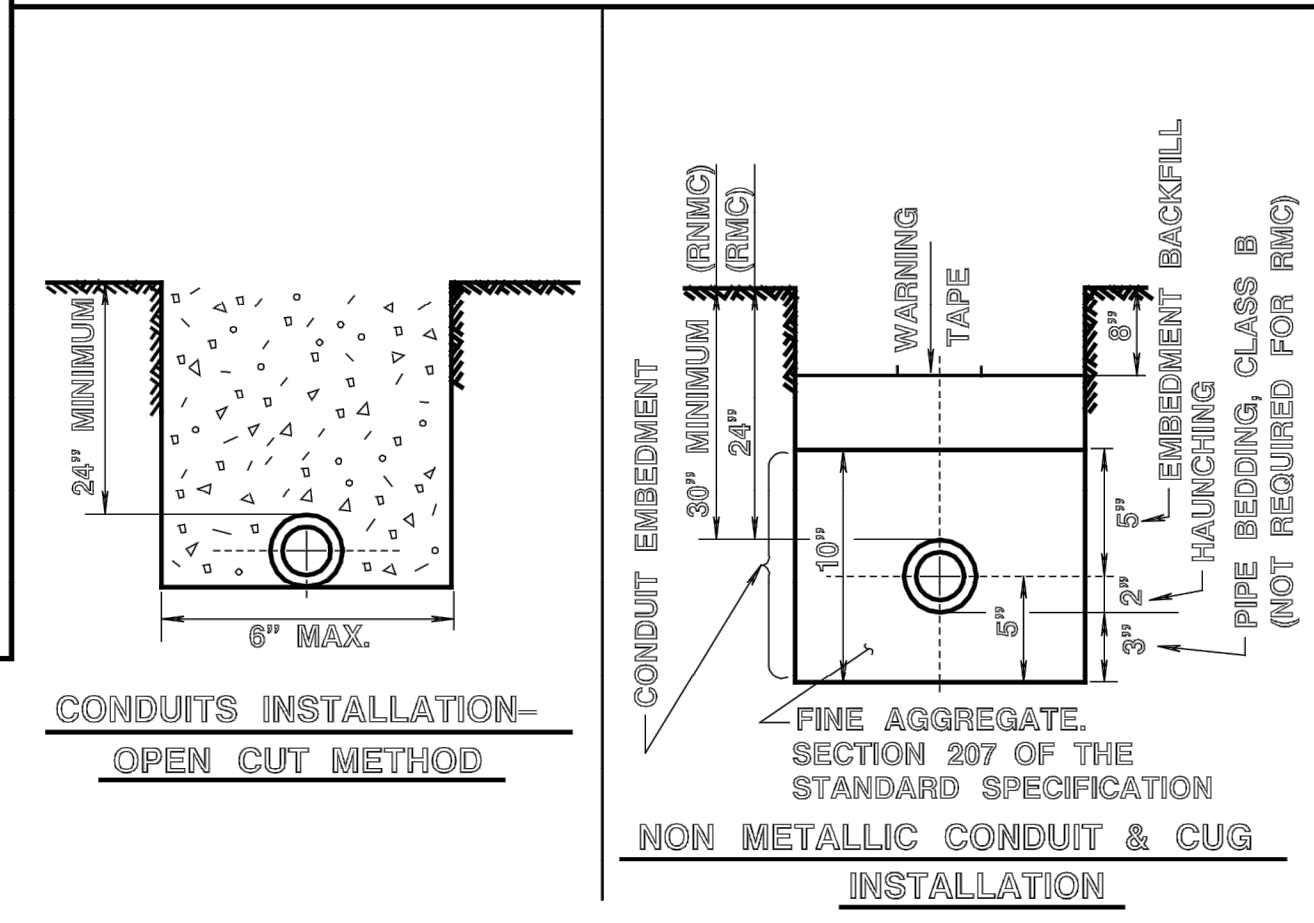
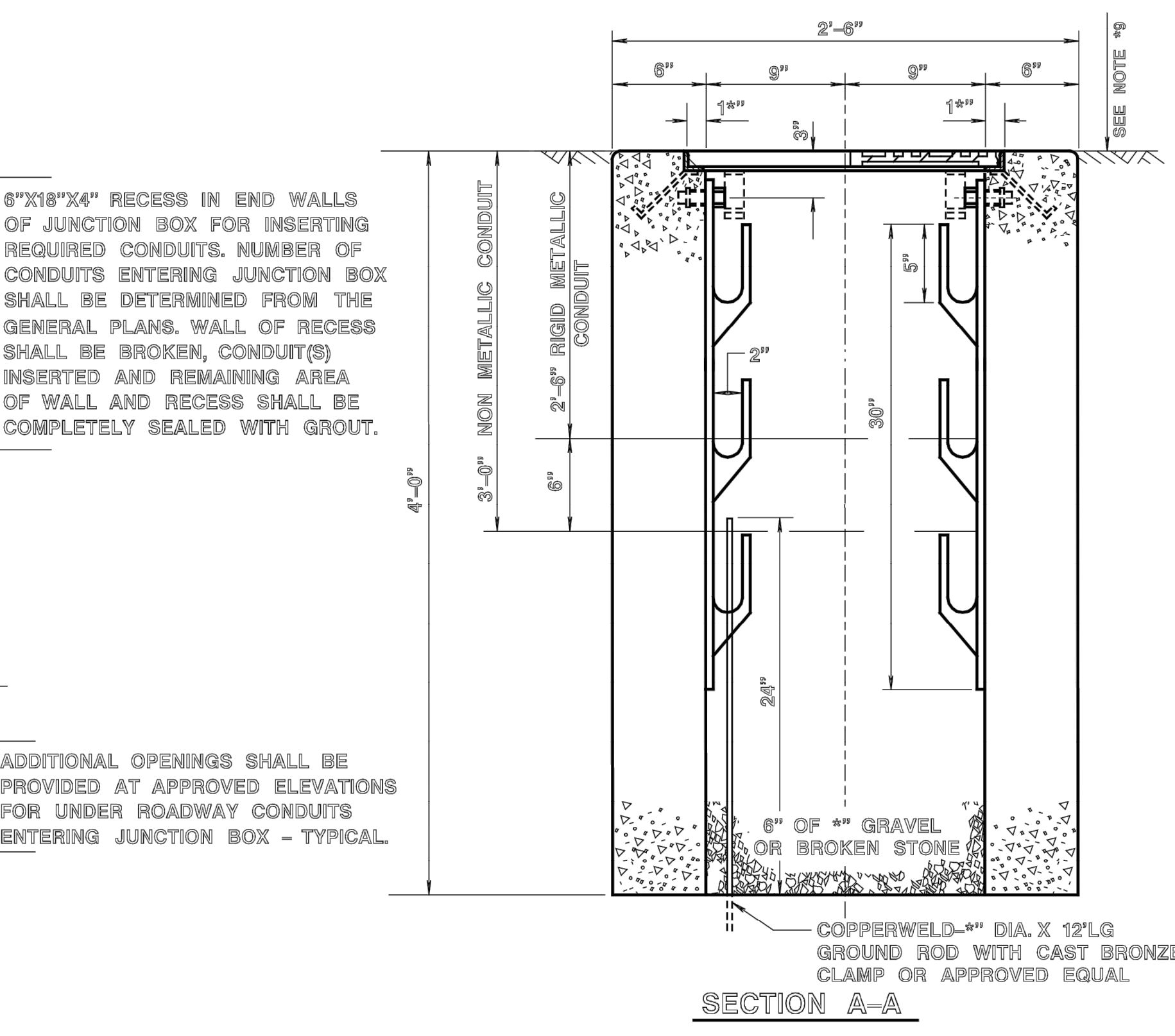
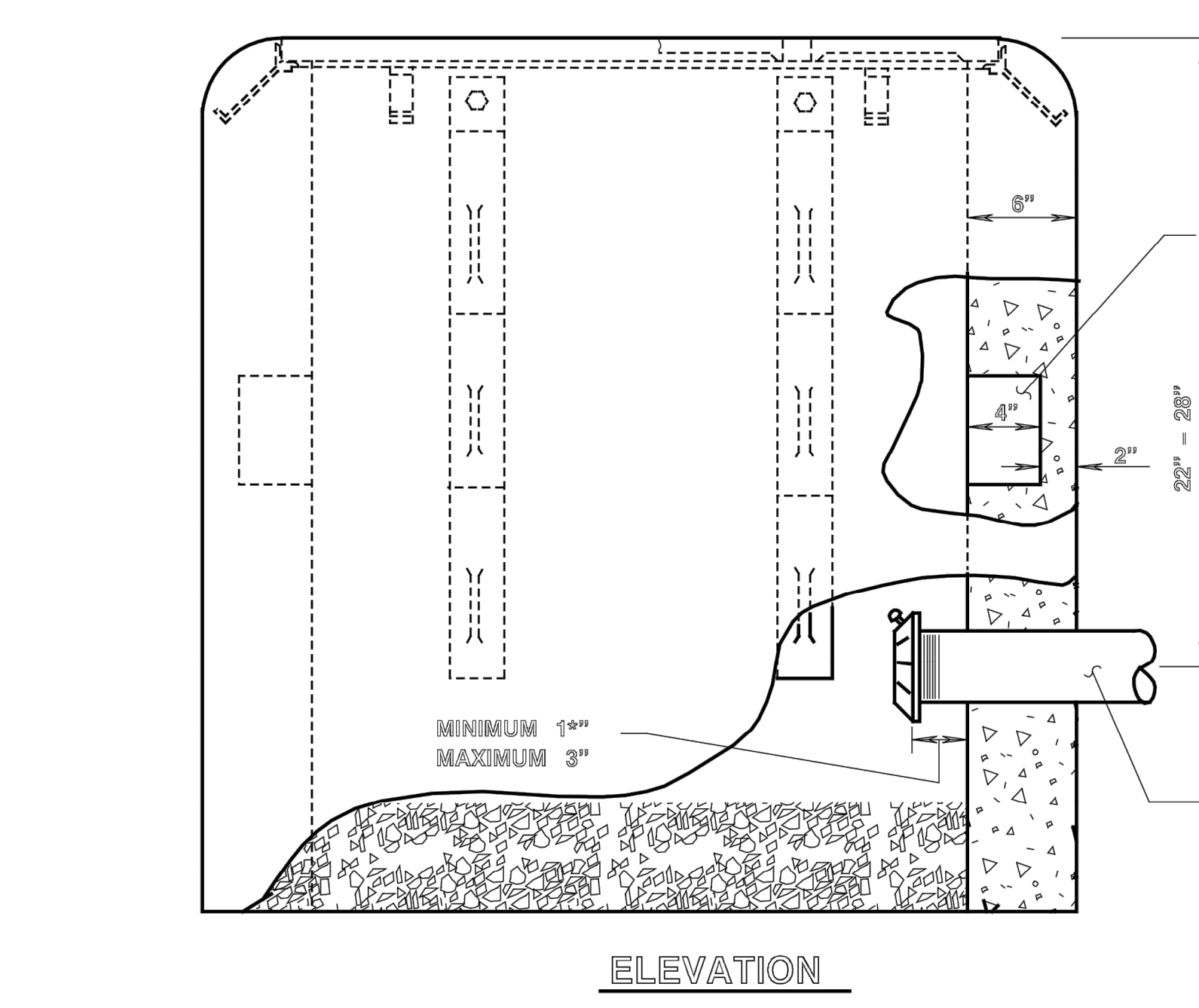

WARNING TAPE
 CAUTION CAUTION CAUTION
 ELECTRIC LINE BURIED BELOW

BLACK LETTERS ON RED BACKGROUND

NEW JERSEY DEPARTMENT OF TRANSPORTATION	
ELECTRICAL DETAILS	
N.T.S.	
18" X 36" JUNCTION BOX CAST IN PLACE TYPE TYPICAL INSTALLATION OF JUNCTION BOX & UNDER ROADWAY CONDUIT	
L-0607	30A 31

FIXED LENGTH NON-ADJUSTABLE SWING SIGN BRACKET

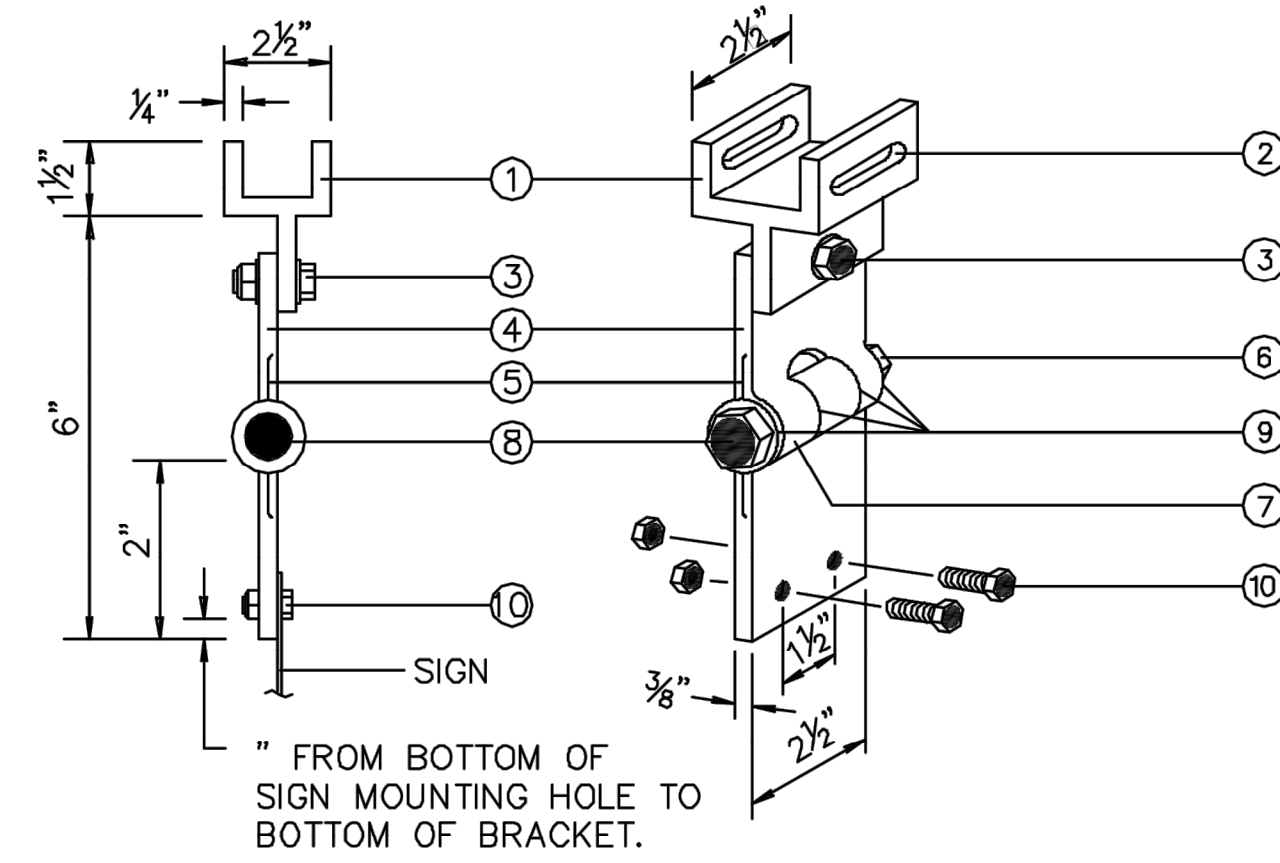

" FROM BOTTOM OF SIGN MOUNTING HOLE TO BOTTOM OF BRACKET.

ADJUSTABLE LENGTH SWING SIGN BRACKET

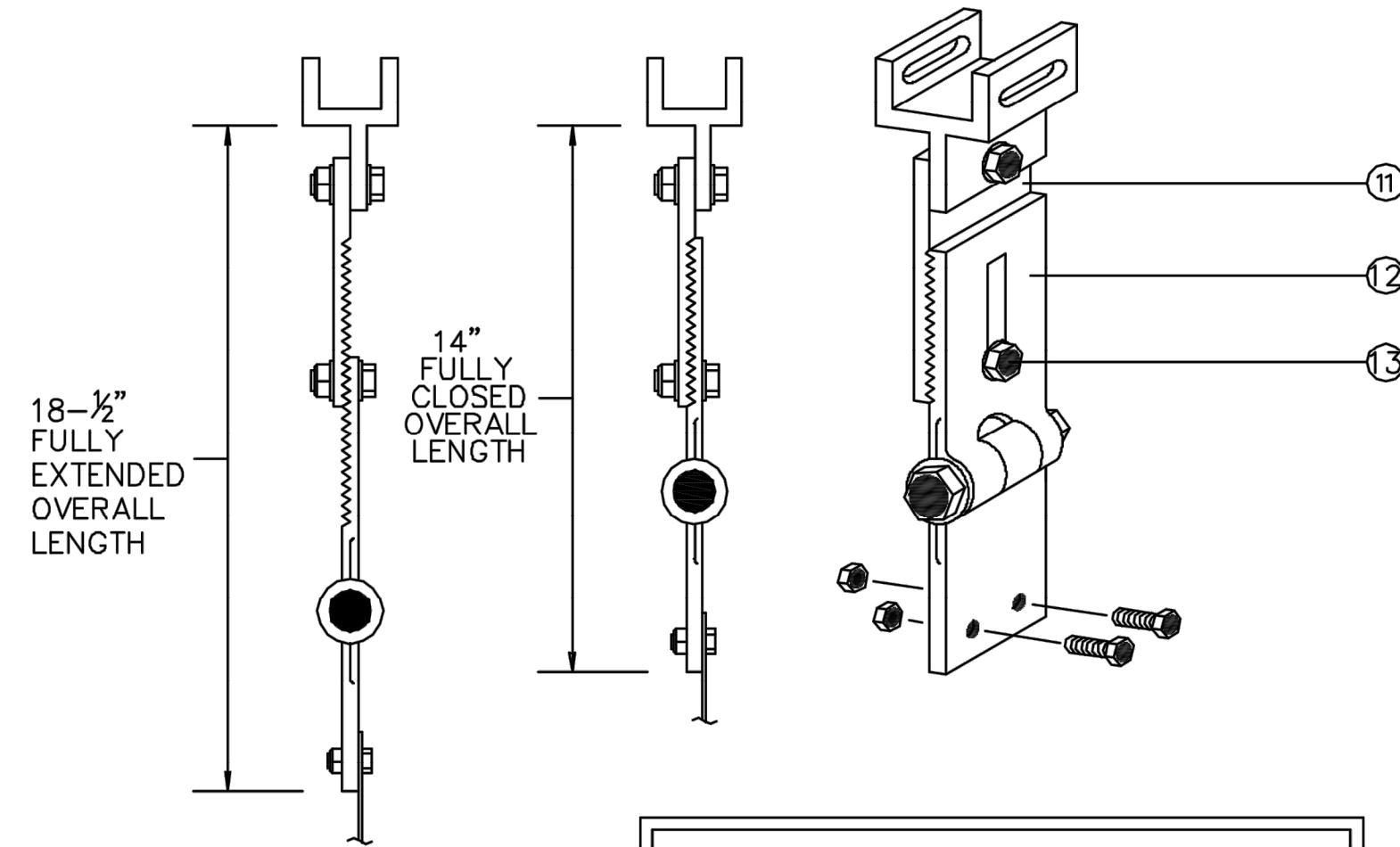

EXTENDER ADAPTERS

FOR ADJUSTABLE LENGTH SWING SIGN BRACKET. EXTENDS BRACKET TO LEVEL SIGN. FITS ANY DEGREE OF MAST ARM RISE.

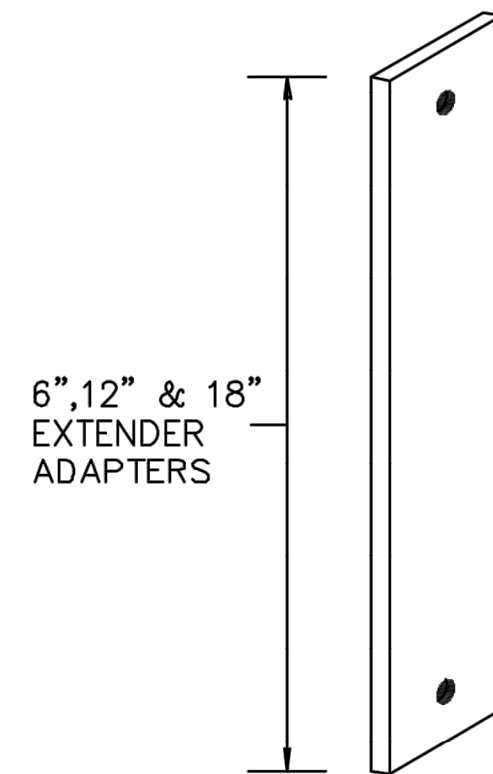

EXTENDER ADAPTERS ARE ALL ALUMINUM 6061T6 ALLOY. 3/8" THICK x 2 1/2" WIDE BAR x VARIABLE LENGTH COMPLETE WITH ONE HOLE EACH END FOR 1/2" BOLT. EACH EXTENDER BAR INCLUDES ONE PIVOT POINT 1/2"-13 x 1 1/2" STAINLESS STEEL HEX HEAD BOLT WITH HEX LOCK NUT AND 2 WASHERS. (EXTENDER ADAPTERS ARE AVAILABLE IN VARIABLE LENGTHS ON REQUEST.)

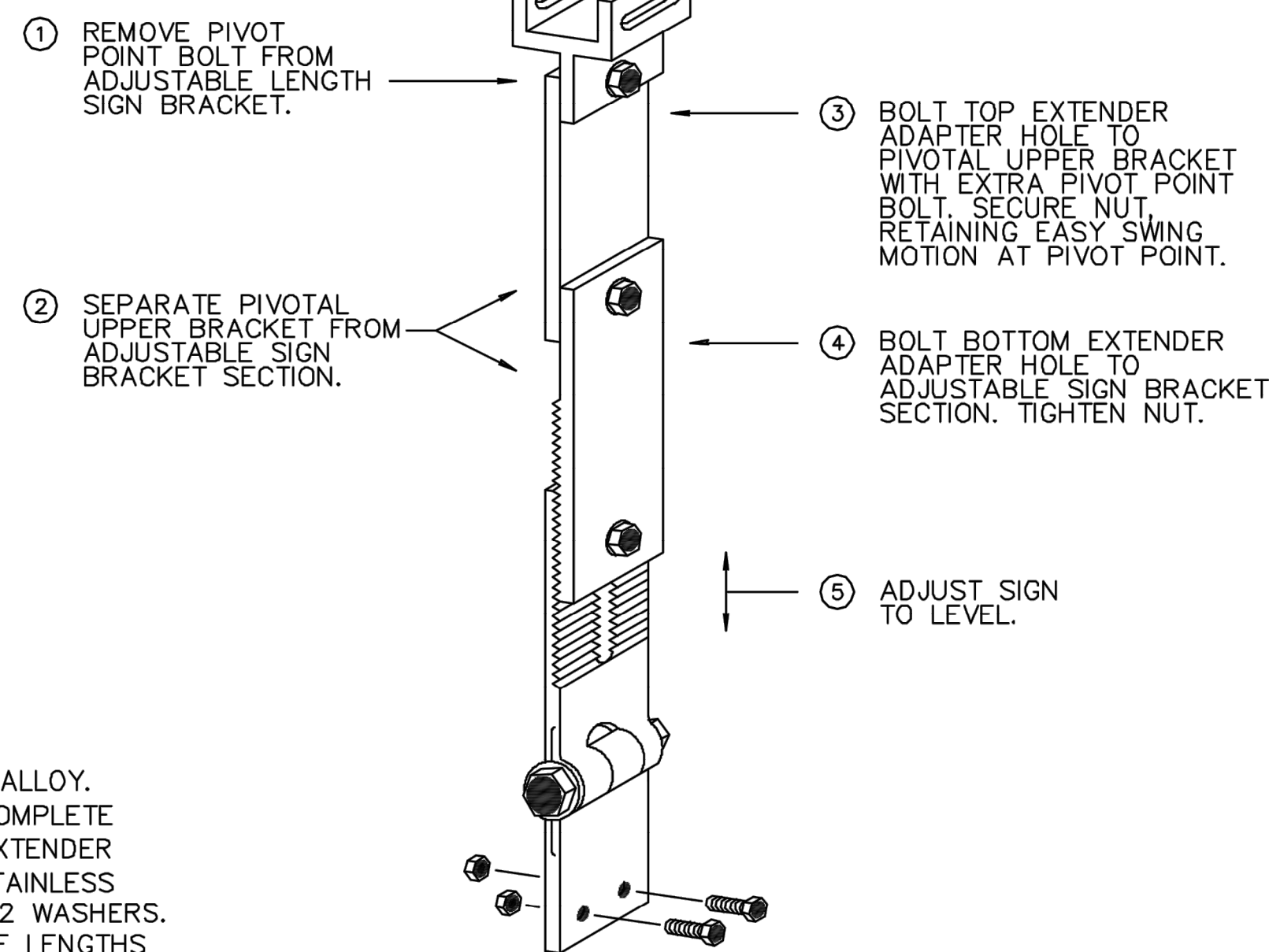

- ① PIVOTAL UPPER BRACKET.
- ② 1 5/8" x 1/4" SLOT FOR DOUBLE STRAPPING TO MAST ARM. (M2G-34S(HD) .030 x 3/4" HEAVY DUTY STAINLESS STEEL STRAP WITH M2G-34B(HD) BUCKLE RECOMMENDED.)
- ③ 1/2"-13 x 1 1/2" STAINLESS STEEL HEX HEAD BOLT WITH STAINLESS STEEL HEX LOCK NUT AND STAINLESS STEEL WASHER (BOTH SIDES). ALLOWS UPPER BRACKET TO PIVOT AND ALIGN WITH MAST ARM.
- ④ 6" OVERALL DROP WITH FIXED LENGTH SIGN BRACKET.
- ⑤ STAINLESS STEEL DAMPENER SPRING (REMOVABLE).
- ⑥ STAINLESS STEEL HEX LOCK NUT WITH 1/8" STAINLESS STEEL WASHER.
- ⑦ 1" O.D. AXLE HOUSING.
- ⑧ 1/2"-13 x 4" STAINLESS STEEL HEX HEAD BOLT WITH 1/8" STAINLESS WASHER.
- ⑨ OILITE BUSHING.
- ⑩ SIGN MOUNTING SETS, CONSISTING OF TWO EACH 5/16"-18 x 1" STAINLESS STEEL HEX HEAD BOLT WITH STAINLESS STEEL HEX LOCK NUT. TWO HOLES ON 1 1/2" CENTERS PROVIDE POSITIVE LOCK SIGN MOUNTING TO BRACKET.

- ⑪ 8 1/4" OVERALL LENGTH UPPER ADJUSTABLE SIGN BRACKET SECTION.
- ⑫ 9" OVERALL LENGTH LOWER ADJUSTABLE SIGN BRACKET SECTION, INCLUDING AXLE HOUSING (8" OVERALL LENGTH TO TOP OF AXLE HOUSING).
- ⑬ 1/2"-13 x 1 1/2" STAINLESS STEEL HEX BOLT WITH STAINLESS STEEL HEX LOCK NUT AND STEEL WASHERS (BOTH SIDES). LOOSEN LOCK NUT, ADJUST BRACKET TEETH TO LEVEL SIGN.

MAST ARM ASSEMBLY BRACKET

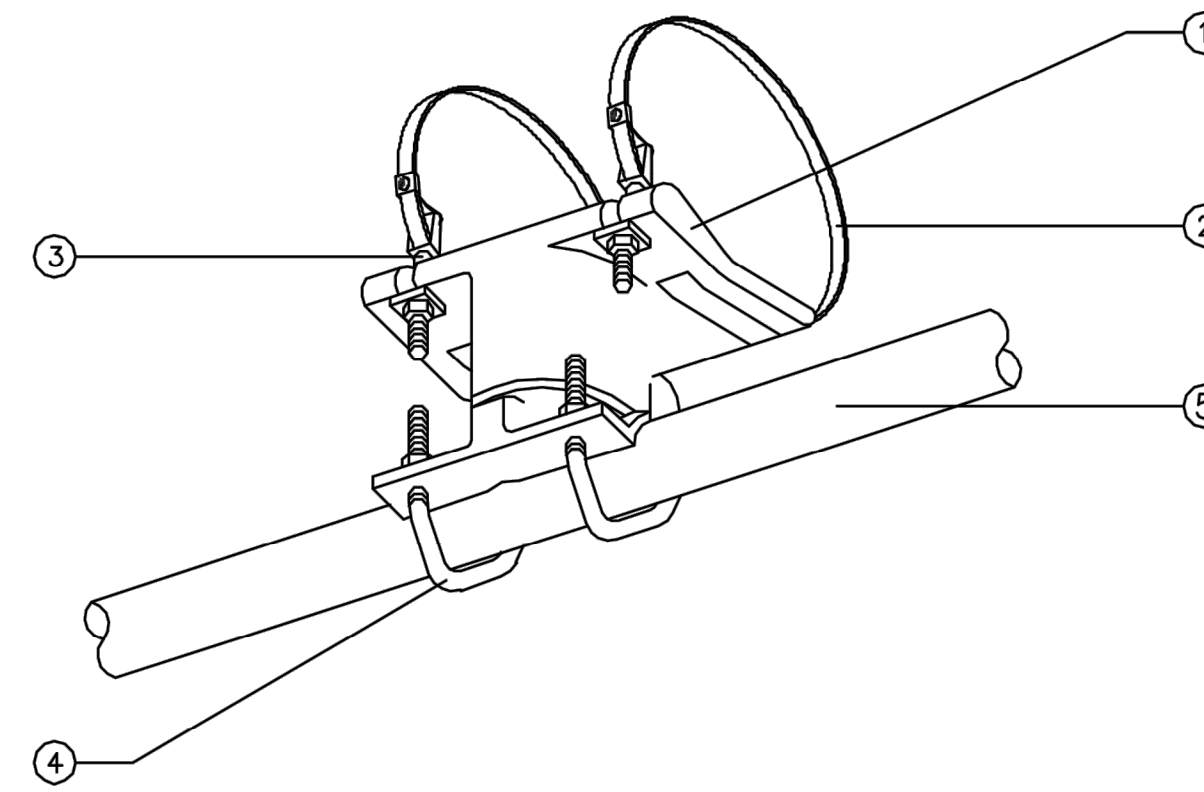

SLIDER CLAMP

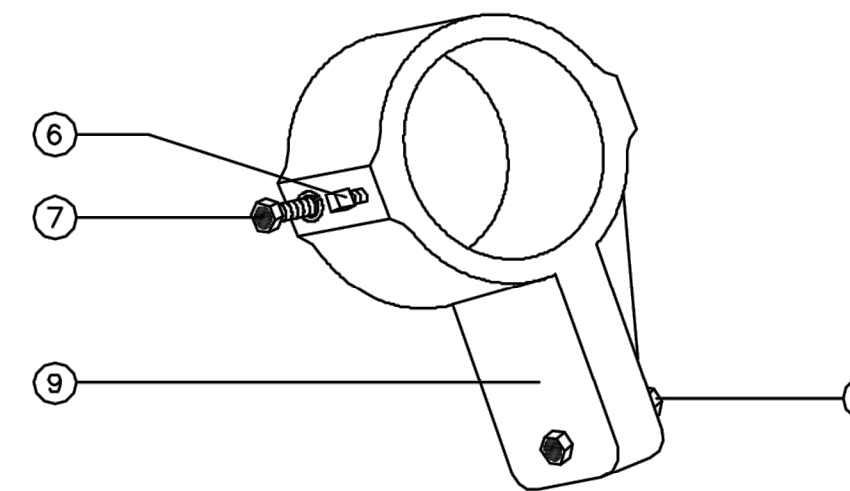

- ① CLAMP SHALL BE ALUMINUM ALLOY (356-T6)
- ② 5/8" STAINLESS STEEL STRAP (2) WITH 5/8" BANDCLAMP.
- ③ STAINLESS STEEL CLAMP SCREW WITH BEARING WASHER, 7/16" FLATWASHER & 7/16" - 14 HEX NUT. CLAMP SCREW SHALL BE INSTALLED WITH MAINTAINING A MINIMUM OF 1/4" CLEARANCE TO THE MAST ARM CLAMP.
- ④ 5/16" - 18 x 1 3/4" x 2 5/8" x 7/8" U-BOLT WITH 5/16" SPLIT LOCKWASHER & 5/16" - 18 HEX NUT.
- ⑤ 1 1/2" ALUMINUM TUBE
- ⑥ 3/8" SQUARE HEAD SET SCREW
- ⑦ 5/16" x 1 1/2" HEX BOLT WITH LOCKWASHER
- ⑧ 3/8" x 1 1/2" STAINLESS STEEL HEX HEAD BOLT WITH STAINLESS STEEL HEX LOCK NUT AND 1/8" STAINLESS STEEL WASHER (BOTH SIDES). A BRONZE REDUCER BUSHING (1/2" TO 3/8") SHALL BE USED INSIDE THE SLIDER CLAMP.
- ⑨ CAST ALUMINUM SLIDER CLAMP

NOTE:
INSTALLATION OF SLIDER:
DRILL 3/8" HOLE THRU ONE WALL OF PIPE.
TIGHTEN 5/16" x 1 1/2" HEX BOLT WITH LOCKWASHER INTO SLIDER THRU HOLE IN PIPE. ATTACH 3/8" SQUARE HEAD SET SCREW.

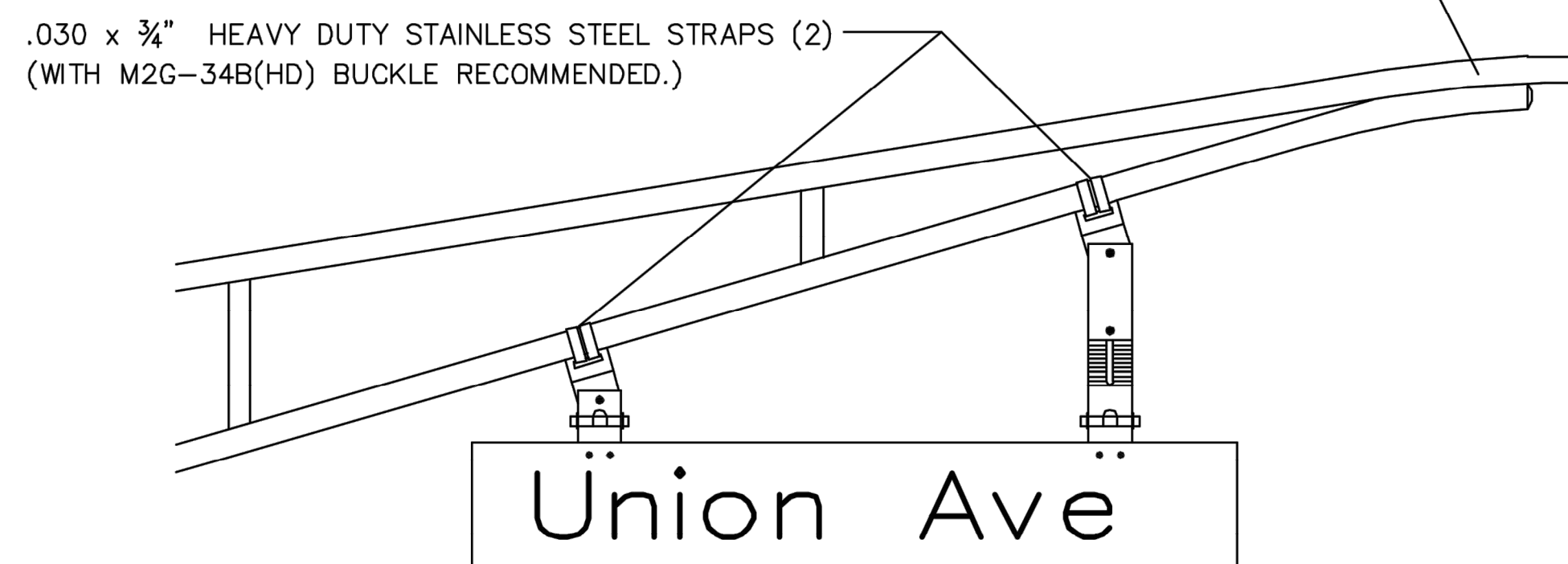
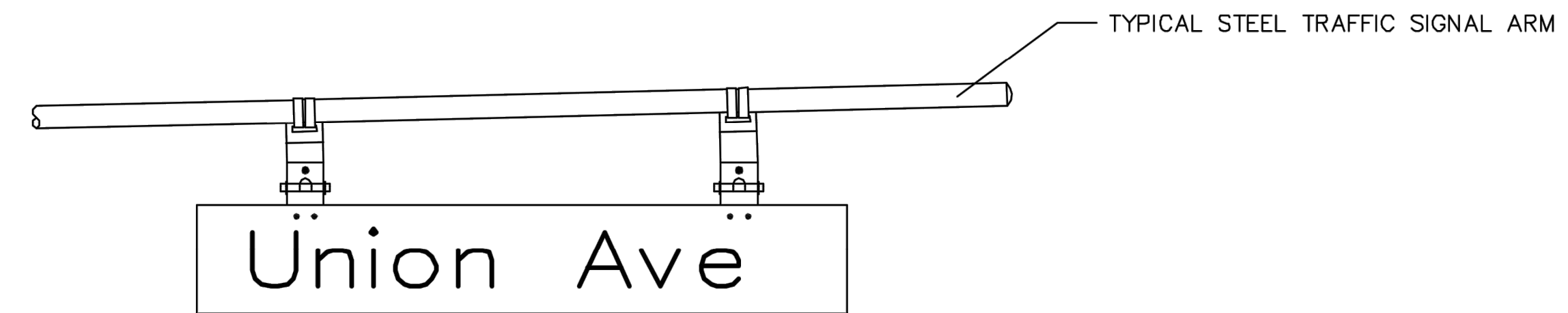
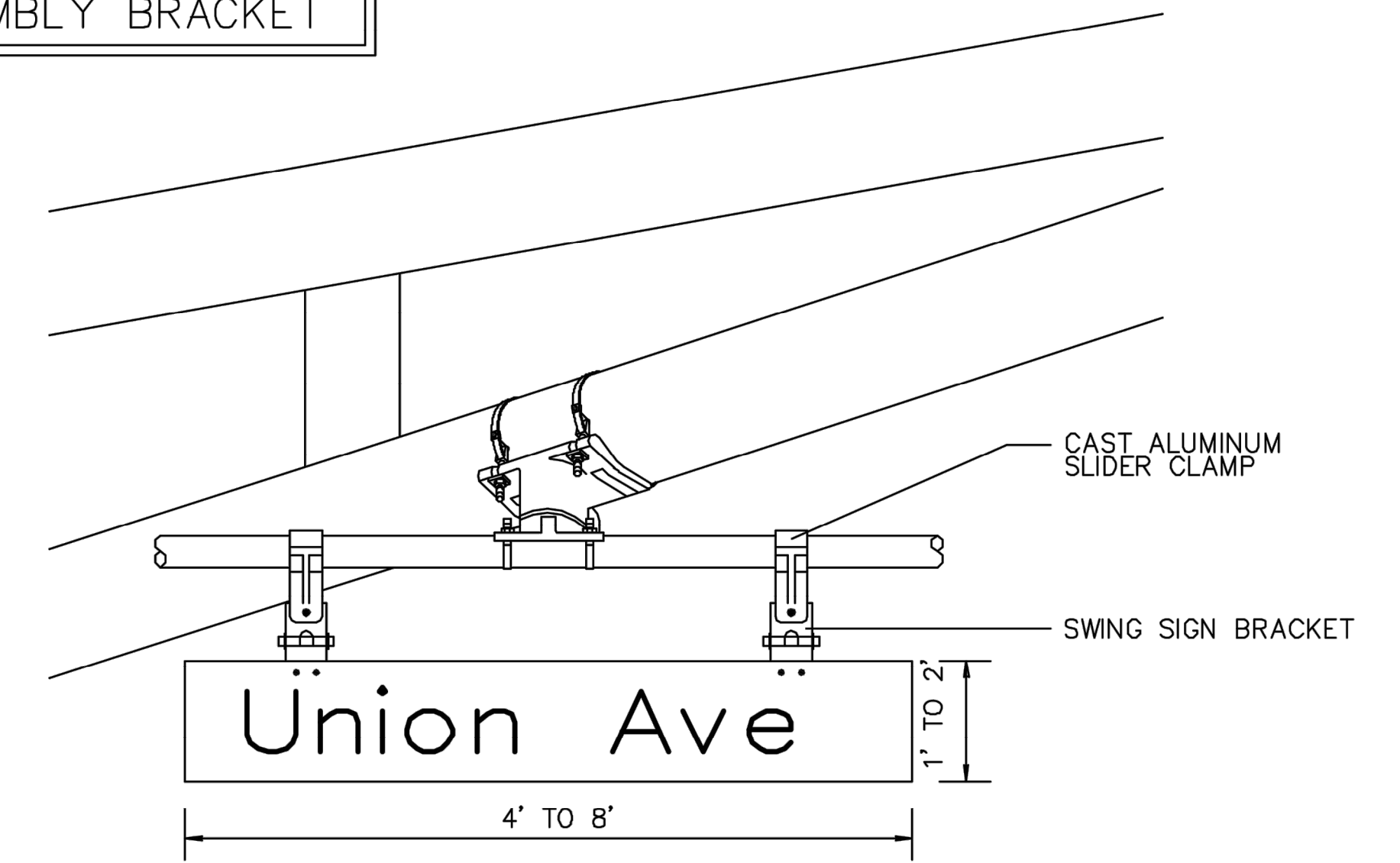

REVISION	BY	DATE
UNION COUNTY, DIVISION OF ENGINEERING		
ELECTRICAL DETAILS		
OVERHEAD MAST ARM ADJUSTABLE SWING SIGN BRACKETS		
COUNTY OF UNION 2325 SOUTH AVENUE SCOTCH PLAINS, NJ 07076	SHEET NO. 31 OF 31	