

**SPECIFICATIONS
FOR
GALLOPING HILL G.C.
2019 IRRIGATION IMPROVEMENT PROJECT
TOWNSHIP OF KENILWORTH
COUNTY OF UNION, NEW JERSEY**

BA#9-2019; UNION COUNTY ENGINEERING PROJECT #2019-002

MARCH 2019

**UNION COUNTY OFFICIALS
BOARD OF CHOSEN FREEHOLDERS**

Bette Jane Kowalski, Chair
Alexander Mirabella, Vice Chairman
Angel G. Estrada, Freeholder
Angela R. Garretson, Freeholder
Sergio Granados, Freeholder
Christopher Hudak, Freeholder
Kimberly Palmieri-Mouded, Freeholder
Andrea F. Staten, Freeholder
Rebecca Williams, Freeholder

CLERK OF THE BOARD
James E. Pellettiere, RMC

COUNTY MANAGER
Edward T. Oatman

**DEPARTMENT OF ENGINEERING, PUBLIC WORKS AND
FACILITIES MANAGEMENT**

Joseph A. Graziano, Sr., CPWM
Director, Department of Engineering, Public Works and
Facilities Management

**COUNTY ENGINEER
DIVISION OF ENGINEERING**
Thomas O. Mineo, P.E.
2325 South Avenue
Scotch Plains, New Jersey 07076
Telephone: (908) 789-3675
Fax: (908) 789-3674

**COUNTY OF UNION
NOTICE TO BIDDERS**

Sealed bids will be received by the director of the Division of Purchasing, or her designee, at the County of Union, New Jersey on March 20, 2019 at 10:30 a.m., prevailing time, in the 3rd Floor Conference Room, U.C. Administration Building, 10 Elizabethtown Plaza, Elizabeth, New Jersey for:

**GALLOPING HILL G.C.
2019 IRRIGATION IMPROVEMENT PROJECT
TOWNSHIP OF KENILWORTH
COUNTY OF UNION, NEW JERSEY
BA#9-2019; UNION COUNTY ENGINEERING PROJECT #2019-002**

Bid Packages may be obtained at no charge by registering and downloading at <http://ucnj.org/bid-specs>. Bid Packages may also be obtained in person from the Division of Engineering at 2325 South Avenue, Scotch Plains, New Jersey 07076 between 8:30 a.m. and 4:00 p.m. weekdays upon payment of a non-refundable money order or bank check in the amount of \$275.00 made payable to the County of Union. No Personal / Company checks will be accepted. Requests for mailing of specifications will not be honored. For further information please call 908-789-3675.

The County reserves the right to reject any and all bids and to waive any and all informalities in the bid in accordance with the New Jersey Local Public Contracts Law.

Bids shall be submitted in a sealed envelope and clearly marked with the subject of the bid, name and address of the bidder, phone & fax number, and date of the bid opening. Each bid must be delivered to reach the Division of Purchasing prior to the stated time of the opening of the bids. The County will not be responsible for late delivery by the U.S. Mail or any other carrier. If hand delivered, please note that parking and security access at the County Complex may cause delays and bidders should take them into consideration in order to submit a timely bid. **No** late bids will be accepted.

Bidders are required to comply with the requirements of N.J.S.A. 10:5-31 et seq. and N.J.A.C. 17:27.

LAURA M. SCUTARI, QPA, MPA, DIRECTOR OF PURCHASING

**UNION COUNTY BOARD
OF CHOSEN FREEHOLDERS**

We're Connected to You!

**GALLOPING HILL G.C.
2019 IRRIGATION IMPROVEMENT PROJECT
TOWNSHIP OF KENILWORTH
COUNTY OF UNION, NEW JERSEY
BA#9-2019; Union County Engineering Project #2019-002**

TABLE OF CONTENTS

Cover Sheet: County Officials
NB-1: Notice to Bidders

GENERAL SPECIFICATIONS

Definitions

- Section 1: BID FORM
- Section 2: WITHDRAWAL OF BID DUE TO MISTAKE
- Section 3: QUALIFICATIONS OF BIDDERS AND REQUIRED SUBMISSIONS
- Section 4: INTERPRETATIONS AND ADDENDA
- Section 5: OBLIGATION OF BIDDER TO INSPECT SITE AND CONTRACT DOCUMENTS
- Section 6: BID AND PERFORMANCE GUARANTEE
- Section 7: COMMENCEMENT AND COMPLETION
- Section 8: BIDDER AFFIDAVIT
- Section 9: BID SECURITY
- Section 10: LABOR AND MATERIALS
- Section 11: INSURANCE REQUIREMENTS
- Section 12: INDEMNIFICATION REQUIREMENTS
- Section 13: ROYALTIES AND PATENTS
- Section 14: PLANS AND SPECIFICATIONS
- Section 15: GUARANTEE AGAINST DEFECTIVE WORK
- Section 16: TRAFFIC AND STREET MAINTENANCE
- Section 17: CONTRACTOR'S EMPLOYEES
- Section 18: OWNERSHIP DISCLOSURES REQUIRED
- Section 19: NON-COLLUSION AFFIDAVIT
- Section 20: EQUAL EMPLOYMENT OPPORTUNITY COMPLIANCES
- Section 21: COMPLIANCE WITH NEW JERSEY PREVAILING WAGE ACT
- Section 22: BRAND NAME OR EQUAL
- Section 23: LINES AND GRADES
- Section 24: NUMBER OF WORKING DAYS
- Section 25: PROMPT PAYMENT OF CONSTRUCTION CONTRACTS (NJ Prompt Payment Act)
- Section 26: STOPPING WORK ON ACCOUNT OF BAD WEATHER
- Section 27: ACCESS FOR OTHER CONTRACTORS
- Section 28: CONDEMNED MATERIALS AND WORK
- Section 29: STORAGE
- Section 30: FINAL CLEAN UP
- Section 31: SUB-LETTING OF WORK
- Section 32: SAFETY
- Section 33: QUALITY, SAFETY AND PERFORMANCE STANDARDS
- Section 34: MATTERS NOT MENTIONED IN CONTRACT DOCUMENTS
- Section 35: PERMITS
- Section 36: CONTRACTOR TO PROVIDE PROOF OF PAYMENT
- Section 37: CHANGE ORDERS
- Section 38: SUPPLEMENTAL WORK
- Section 39: FORM OF CONTRACT
- Section 40: PROGRESS PAYMENTS
- Section 41: INSPECTION
- Section 42: DAMAGES
- Section 43: LIQUIDATED DAMAGES
- Section 44: AFFIRMATIVE ACTION REQUIREMENTS
- Section 45: INVESTMENT ACTIVITIES WITH IRAN

GENERAL SPECIFICATIONS CONTINUED

- Section 46: COMPLIANCE WITH THE PUBLIC WORKS CONTRACTOR REGISTRATION ACT
(N.J.S.A. 34:11-56.48 et seq)
- Section 47: UTILITIES
- Section 48: MATERIAL COMPLIANCE AND SHOP DRAWINGS
- Section 49: PRECONSTRUCTION
- Section 50: DISPUTES UNDER THE CONTRACT
- Section 51: CONTRACTOR BUSINESS REGISTRATION CERTIFICATE
(New Mandatory Requirement – Effective 1/18/2010)
- Section 52: BID PROTEST - LEGAL FEES AND COSTS
- Section 53: AMERICAN GOODS AND PRODUCTS WHERE POSSIBLE
- Section 54: NEW JERSEY PAY-TO-PLAY REQUIREMENTS
- Section 55: STATEMENT OF EQUIPMENT TO BE USED IN CONSTRUCTION
- Section 56: NEW JERSEY SALES AND USE TAX REQUIREMENTS

BIDDING DOCUMENTS

- Bid Document Submission Checklist
- Bidding Documents
- Bid Form
- Consent of Surety
- Bidder Signature Page
- Bidder Disclosure Statement
- Subcontractor Identification Statement: List of Subcontractors
- Subcontractor Identification Certification
- Acknowledgement of Addendum
- Contractor Business Registration Certificate
- Affirmative Action Requirement
- Experience Statement
- Certificate of Bidder Showing Ability to Perform Contract
- Non-Collusion Affidavit
- Contractor Registration Advisement
- Americans with Disabilities Act
- Statement of Bidder's Qualifications
- Contractor Performance Record
- Affidavit Regarding List of Disbarred, Suspended or Disqualified Bidders
- Prior Negative Experience Questionnaire-Certification
- Contractor's Certification of Compliance - New Jersey Prevailing Wage Act
- Uncompleted Contracts Affidavit
- Certificate of Insurance Statement
- Collection of Use Tax on Sales to Local Governments Statement
- Time of Completion
- Disclosure of Investment Activities in Iran

STANDARD SPECIFICATION FORM - SS-1

NEW JERSEY PREVAILING WAGE DETERMINATION DOCUMENTS

PROJECT TECHNICAL SPECIFICATIONS

**UNION COUNTY BOARD OF CHOSEN FREEHOLDERS
INSTRUCTIONS TO BIDDERS AND FORMS**

DEFINITIONS

Wherever reference is made to the County, Title of Project, Bidder, or Vendor/Contractor they shall be as follows:

OWNER/COUNTY:

Union County Board of Chosen Freeholders
UC Administration Building, 6th Floor
10 Elizabethtown Plaza
Elizabeth, New Jersey 07207

ADDRESS BIDS AND SUBMIT TO:

Union County Division of Purchasing
UC Administration Building, 3rd Floor
10 Elizabethtown Plaza
Elizabeth, NJ 07207
Attn: Laura M. Scutari, QPA, MPA, Director, Division of Purchasing
Telephone: 908-527-4130
Facsimile: 908-558-2548

TITLE OF PROJECT: GALLOPING HILL G.C.

**2019 IRRIGATION IMPROVEMENT PROJECT
TOWNSHIP OF KENILWORTH
COUNTY OF UNION, NEW JERSEY
BA#9-2019; Union County Engineering Project #2019-002**

BIDDER: Bidder shall be a single overall contract bidder

ENGINEER: Thomas O. Mineo, P.E., County Engineer
Division of Engineering
2325 South Avenue, Scotch Plains, New Jersey 07076

COUNTY ENGINEER AND/OR CONSTRUCTION MANAGER (as applicable):

COUNTY ENGINEER:

Thomas O. Mineo, P.E.
Union County
Division of Engineering
2325 South Avenue
Scotch Plains, NJ 07076
Office: (908) 789-3675
Facsimile: (908) 789-3674
Email: tmineo@ucnj.org

CONSTRUCTION MANAGER:

GENERAL SPECIFICATIONS

1. BID FORM

Bids for this Work will be enclosed in a sealed envelope addressed to the Purchasing Division, County of Union, New Jersey, Union County Administration Building, 10 Elizabethtown Plaza, Elizabeth, New Jersey 07207, with the full name of the Project clearly marked on the outside. Refer to the sheet marked "Notice of Bid (Advertisement)" for the correct name of the Project. Bidders must submit their bids on the attached pricing sheet (Bid Form), in a sealed envelope addressed to the County and bearing on the outside: the name of the Bidder, Bidder's business address, and the title of the Project.

The Division of Purchasing will receive the bids for this Work at the Union County Administration Building, 10 Elizabethtown Plaza, Elizabeth, New Jersey on the date and time noted on the sheet marked "**Notice of Bid (Advertisement)**".

The County will not assume responsibility for bids forwarded by mail. It is the individual's responsibility to see that the bids are presented to the Purchasing Division at the time and at the place designated.

Bids will be accepted only on the Bid Form supplied. Bids on forms other than the original supplied herein will be rejected. The "complete" Bid Documents includes the Bid Bond, Bid Form, Bidder's Checklist, Consent of Surety, Ownership Disclosure Certification, Non-Collusion Affidavit, and any other documents noted in these Instructions to Bidders or Contract Document to be submitted with this Bid.

The bidder will state in the bidding sheet the price per unit of measure for each scheduled Item of Work for which he will agree to carry out the Work, and the Total Bid Price for the construction of the Project.

The prices in the Bid Form shall be typed or written in pen and ink. Erasures or alterations must be initialed by the bidder in ink.

The bidding sheet for this Project may include a fixed amount as a Bid Allowance. If applicable, all bidders are required to add this fixed amount to their base bid and to include this additional amount in their Bid Bond. This sum will be included in the Contract as well as the performance, labor and materials bond. Payment by the County will be made to the Contractor from these funds only upon the completion of extra Work pursuant to a written Change Order(s) signed by the County's Engineer or his designee and the Contractor, prior to the commencement of such Work. Work commenced prior to written approval by the County shall be done at Contactor's risk. Such payment will only be in the amount agreed to by the parties, in writing in the Change Order(s). See Section 37, Change Orders, of these general specifications for further details.

Refer to Bid Document Submission Checklist for all required documents.

In the event there is a discrepancy between the unit price given and the extended total, the unit price will govern. Any discrepancies will be mathematically adjusted.

Insert applicable alternates, if any have been specified, applicable to the Bidder's Work. All alternates MUST be bid upon. Any Bidder's failure to do so will be deemed a material, non-waivable defect and shall render the bid nonresponsive. The Bidder shall clearly designate whether the change in price is an addition or subtraction, by using either a "+" sign or the word "addition", or in the alternative, a "-" sign or the word "minus". If there is no other change in price, the Bidder shall insert "NC" or "No Charge".

When two or more low bids are equal in all respects, awards will be made according to the provisions of N.J.S.A. 40A:11-6.1(d).

Where unit prices have already been established by the Contract Documents, the Bidder agrees that such unit prices shall prevail. All unit prices, whether filled in by the Bidder or established by the Contract Documents, shall become part of the Contract. No bid will be considered or award made, unless applicable unit prices, as required, are filled in.

The County reserves the right to reject any or all bids and also reserves the right to waive any informality in the bids received so long as said waiver is not of a response which is considered to be material and non-waivable pursuant to law.

The County of Union has the right to reject any and all bids from any bidder that is in, or contemplates bankruptcy of any chapter of nature. Said bidder shall notify the County, in writing, of any condition or knowledge of the same.

Conditional bids will not be accepted. Bids may be withdrawn prior to the advertised time for the opening of bids or authorized postponement thereof or in accordance with the provisions of N.J.S.A. 40A:11-23.3 discussed below. Bids received after the advertised time shall not be considered. Bidders shall be solely responsible for premature opening or late delivery of bids not properly marked, addressed, or directed.

2. WITHDRAWAL OF BID DUE TO MISTAKE

N.J.S.A. 40A:11-23.3 authorizes a bidder to request withdrawal of a public works bid due to a mistake on the part of the bidder. A mistake is defined by N.J.S.A. 40A:11-2(42) as a clerical error that is an **unintentional and substantial computational error or an unintentional omission of a substantial quantity of labor, material, or both, from the final bid computation.**

A bidder claiming a mistake under N.J.S.A. 40A:11-23.3 must submit a request for withdrawal, **in writing**, by certified or registered mail to Laura M. Scutari, QPA, MPA,

Director, Division of Purchasing, County of Union, New Jersey, Union County Administration Building, 10 Elizabethtown Plaza, Elizabeth, New Jersey 07207. The bidder must request withdrawal of a bid due to a mistake, as defined by the law, within five business days after the receipt and opening of the bids. Since the bid withdrawal request shall be effective as of the postmark of the certified or registered mailing, Laura M. Scutari, QPA, Director of the Division of Purchasing or his designee may contact all bidders, after bids are opened, to ascertain if any bidders wish to, or already have exercised a request to withdraw their bid pursuant to N.J.S.A. 40A:11-23.3.

A bidder's request to withdraw the bid **shall** contain evidence, including any pertinent documents, demonstrating that a mistake was made. Such documents and relevant written information shall be reviewed and evaluated by the County's designated staff pursuant to the statutory criteria of N.J.S.A. 40A:11-23.3.

The County will not consider any written request for a bid withdrawal for a mistake, as defined by N.J.S.A. 40A:11-2(42), by a bidder in the preparation of a bid proposal unless the postmark of the certified or registered mailing is within the five business days following the opening of bids.

3. QUALIFICATIONS OF BIDDERS AND REQUIRED SUBMISSIONS

The County may make such investigation as it deems necessary to determine the ability of the Bidders to perform the Work, which includes investigation of any and all subcontractors listed with the bid. The Bidder shall furnish any information and data for this purpose as the County may request.

4. INTERPRETATIONS AND ADDENDA

Any explanation desired by a bidder regarding the meaning or interpretation of the Contract Documents must be requested in writing to the County Engineer or Design Professional as the case may be and with reasonable time allowed for a reply to reach bidders before submission of their bids. Any interpretation or instruction made by the County Engineer will be in the form of an addendum to the Contract Documents or clarification and will be furnished to all prospective bidders. Oral explanations or instructions given before the award of the Contract will not be binding. Bidders are required to bring to the attention of the County Engineer, the discovery of any apparent ambiguity, inconsistency, error, discrepancy, omission in the Contract Documents for interpretation and correction at least ten (10) working days before opening of bids with the exception of Saturdays, Sundays and holidays.

All Addenda issued through the Offices of the County Engineer are amendments to the Contract Documents and shall be considered in preparing bids. Same shall become part of the Contract Documents.

Addenda take precedence over all earlier documents and over each other according to the latest date. Addenda unless themselves interpretive remain subject to interpretation the same as any other document incorporated in the Contract.

Addenda may be issued by the County Engineer up to seven (7) working days prior to the opening of bids. Failure of any bidder to receive an addendum shall not relieve such bidder from the obligation imposed by such addendum. Bidders are to keep themselves currently acquainted with the Contract Documents during the entire bidding period and make inquiry on their own initiative as to issuance of any Addenda. Receipts of all Addenda shall be acknowledged on the “*Acknowledgement of Receipt of Changes*” included in the bid package and must be submitted with the bid.

5. OBLIGATION OF BIDDER TO INSPECT SITE AND CONTRACT DOCUMENTS

At the time of the opening of bids, each Bidder will be presumed to have inspected the site(s) and to have read, and be thoroughly familiar with the Contract Documents. The failure or neglect of any Bidder to receive or examine any form, instrument, or document shall in no way relieve any Bidder from any obligation in respect to its bid.

The Bidder shall examine the contents of the Project Manual and the set of Drawings and assure itself that all pages of the Specifications, Drawings, and other Contract Documents are included in the documents obtained for bidding purposes. Should the Specifications, Drawings, and other Contract Documents be incomplete, the Bidder shall notify the County Engineer in writing, who will supply the Bidder with any missing pages of Specifications, Drawings, or other Contract Documents. The lack of such written notification by the Bidder will be construed as evidence that the Specifications, Drawings, or other Contract Documents supplied it for bidding purposes are full and complete and as a waiver of any subsequent claim to the contrary.

6. BID AND PERFORMANCE GUARANTEE

Each bidder must furnish a Bid Bond, Certified Check or Bank Cashier’s Check in the amount of ten percent (10%) of the Bid. Checks shall be drawn to the order of the County of Union, New Jersey, not to exceed \$20,000.

Each bidder must furnish with the bid a certificate from a Surety Company, i.e. Consent of Surety, stating that in the event of the contract being awarded to said bidder, such Surety Company will provide the Contractor with Bonds guaranteeing the faithful performance of the Work in accordance with the plans and specifications, and the payment for labor, materials, and all other indebtedness which may accrue on the account of this Work. A Performance, Labor and Materials bond will be furnished by the Contractor upon an award of Contract, and will be in the amount of 100% of the contract price.

A one-year Maintenance Bond will be required upon acceptance of the Project by the County in the amount as stated in Section 15 of the General Specifications. Bonds will be written by a firm authorized to issue the bonds under the laws of the State of New Jersey and be in a form acceptable to the County Counsel.

N.J.S.A. 40A:11-1.1 et seq. allows the prime Contractor to furnish the Performance Security for his Subcontractors. The County of Union requires Performance Security to be furnished by the prime contractor for the entire job in the total amount of the contract.

The County of Union shall award the contract or reject all bids within sixty (60) days; except that the bids of any bidders who consent thereto may, at the request of the County be held for consideration for such longer periods as may be agreed.

The County will return all certified checks or cashier's checks after the proposals have been opened, read, tabulated and checked except those of the three (3) bidders who have bid the lowest total price for carrying out the Project. The County will return the checks of these bidders when a contract is awarded to the successful bidder within ten (10) days after the award of the contract.

If the successful bidder refuses or neglects to sign the said Agreement and furnish the required bonds, the Bid Bond will be held and used by the County to offset any damages for such refusal or neglect.

7. COMMENCEMENT AND COMPLETION

Work will not commence until a Notice to Proceed is received from the County Engineer.

Upon substantial completion of the Project, the Contractor must request a joint inspection with the County Engineer. Upon completion of this inspection, the County Engineer will prepare a list of incomplete or incorrect items (punch list) and have Contractor initial and date same. The Contractor shall rectify all deficiencies noted on the punch list within 30 calendar days of receipt of the list. The County Engineer may approve extensions for extenuating circumstances.

8. BIDDER AFFIDAVIT

All Bidders are required to complete, sign, and submit with their Bid, the attached "Affidavit Regarding List of Debarred, Suspended or Disqualified Bidders". (See form enclosed)

9. BID SECURITY

All Bidders are required to submit a form of Bid Security with their bids.
(Bid Bond or Certified Funds)

The Bid Security shall be in the amount of ten percent (10%) of the Bid, but not in excess of Twenty Thousand Dollars (\$20,000.00), and payable to the order of the "County of Union."

10. LABOR AND MATERIALS

The prices will cover all costs of any nature incident to and growing out of the Work, including all labor, material, equipment, transportation, loss by damage or destruction of the Project, settlement of damages, and for replacement of defective work or materials. N.J.S.A. 54:32B-1 et seq. exempts all materials sold to the County of Union from sales or use taxes and should not be included in the prices provided on the Bidding Sheet.

11. INSURANCE REQUIREMENTS

The County of Union requires all contractors to be able to comply with the following insurance requirements. In the event a bid is accepted by the County, the contractor must accept the applicable insurance requirements, as set forth below, as part of any contract awarded to it by the County.

Contractor shall carry and maintain at all times while the contract is in full force and effect, the following insurance coverage with an insurance company or companies acceptable to the County, with limits not less than those shown below. A Certificate of Insurance shall be filed with the County prior to commencement of any Work indicating the following:

- a) Commercial General Liability (CGL): Coverage for all operations including, but not limited to, contractual, products and completed operations, and personal injury with limits no less than \$5,000,000 per occurrence/\$10,000,000 aggregate. The County of Union, its Board of Chosen Freeholders, officers, employees, agents and servants shall be included as an additional insured. Coverage is provided on a primary and non-contributory basis to the County of Union, et al.
- b) Automobile Liability: Coverage for all owned, non-owned and hired vehicles with limits not less than \$5,000,000 per occurrence, combined single limits (CSL) or its equivalent.
- c) Workers Compensation: As required by the State of New Jersey and Employers Liability with limits not less than \$1,000,000 per accident for bodily injury or disease.

- d) Professional Liability (if design/build): Coverage with limits not less than \$1,000,000 per occurrence or claim, \$2,000,000 aggregate
- e) Contractor's Pollution Legal Liability and/or Asbestos Legal Liability and/or Errors & Omissions (if project involves environmental hazards): Coverage with limits no less than \$1,000,000 per occurrence or claim/\$2,000,000 aggregate.
- f) Builders Risk (for major renovations): During the course of construction utilizing an "All Risk" coverage form with limits equal to the completed value of the project and no coinsurance penalty provisions.

Where applicable, a waiver of subrogation in favor of the County of Union, its Board of Chosen Freeholders, officers, employees, agents, servants and the State of New Jersey is to be included in those policies of insurance where permitted by law.

Notice of Cancellation: Each insurance policy required above shall provide that coverage shall not be canceled, except with notice to the Entity.

Special Risks or Circumstances: The County reserves the right to modify these requirements, including limits, based on the nature of the risk, prior experience, insurer, coverage, or other special circumstances.

12. INDEMNIFICATION REQUIREMENTS

The County of Union requires all bidders to accept the following indemnification requirements in the event the County accepts their bid. The Contract awarded by the County to the successful bidder will contain the following provision:

"To the fullest extent permitted by law the Contractor shall indemnify and hold harmless the owner and the owner's consultants, agents, representatives, and employees from and against any and all claims, damages, losses, costs, and expenses, including, but not limited to attorneys' fees, legal costs and legal expenses arising out of or resulting from the performance of the Contractor's work under this contract, provided that such claim, damage, loss, cost, or expense is attributable to bodily injury, sickness, disease or death, or to injury to or destruction of tangible property (other than the work itself) caused or alleged to be caused by the negligent acts, negligent omissions, and/or fault of the Contractor, anyone directly or indirectly employed or retained by the Contractor, or anyone for whose acts the Contractor may be liable regardless of whether caused in part by the negligent act or omission of a party indemnified hereunder provided it is not caused by the sole negligence of a party indemnified hereunder. Contractor shall further indemnify and hold harmless the County and the County's consultants, agents, representative, and employees from and against any and all claims, damages, losses, costs, and expenses, including, but not limited to attorneys' fees, legal costs and legal expenses, arising out of or resulting from performance of the work, provided that such claim, damage, loss,

cost, or expense is attributable to bodily injury, sickness, disease or death, or to injury to or destruction of tangible property (other than the work itself) caused or alleged to be caused by the negligent acts, negligent omissions, and/or fault of the County or the County's consultants, agents, representatives, or employees and arises out of this project and provided such claim, damage, loss, cost, or expense is not caused by the sole negligence of a party indemnified hereunder."

13. ROYALTIES AND PATENTS

The Contractor shall pay all royalties and license fees. He shall defend all suits or claims for infringement of any patent rights and shall hold the County harmless from loss on account thereof.

14. PLANS AND SPECIFICATIONS

In carrying out the Work, the plan(s) and the specifications will be followed by the Contractor. Minor alterations in the plan may be made or permitted by the County Engineer from time to time and, if no additional Work is necessary, there will be no additional charge for carrying out such minor alterations.

The Contractor shall provide the County Engineer a set of reproducible as-built drawings upon completion of the Project. The Contractor shall maintain an updated construction progress plan in the Project field office at all times.

When applicable, The New Jersey Department of Transportation Standard Specifications for Road and Bridge Construction, as amended, and Supplemental Specifications for State Aid Projects, herein after referred to as the "Standard Specifications", are made a part of these specifications and contract for the improvements, and will govern the construction of this Project, the material used and the execution of this Project, except as revised and modified herein. The references to these specifications are given herein for the purpose of aiding in the rapid location of the description of the various items herein specified. The entire Work must be carried on and completed to the satisfaction of the County. The Standard Specifications are amended as follows:

"Any reference to the Commissioner, Department, Department Laboratory, Engineer or Inspector should be redefined to be the County of Union".

15. GUARANTEE AGAINST DEFECTIVE WORK

Prior to final payment being made or before the release of the performance security required by Section 3 above, the Contractor and Surety shall execute and deliver to the County an original Maintenance Bond with an original signature and seal having a penal sum equal to:

- A) One hundred percent (100%) of the final adjusted Contract amount, if such amount is \$50,000.00 or less;
- B) Fifty percent (50%) of the final adjusted Contract amount, if such amount be greater than \$50,000.00 but less than \$250,000.00; and,
- C) Twenty-five percent (25%) of the final adjusted contract amount, if such amount is \$250,000.00 or more.

The Bond and Surety shall be satisfactory to the Union County Counsel. The Surety shall hold a Certificate of Authorization to do business in the State of New Jersey and shall conform to P.L. 1995 c.384, codified as N.J.S.A. 2A:44-143, 144. The Surety Disclosure Statement and Certification required by N.J.S.A. 2A: 44-143, 144, shall be attached to the Bond. Such Maintenance Bond shall remain in full force and effect for a period of one (1) year from the date of Final Completion. Such Maintenance Bond shall also provide that the Contractor and the Surety guarantee to replace for the said period of one (1) year from the date of Final Completion, all Work performed and/or all materials furnished that were not performed or were not furnished in accordance to the terms and performance requirements of the Contract Documents, and will make good any defects thereof which become apparent before the expiration of one (1) year. If, during that period, any part of the Project, in the judgment of the Engineer, is found defective, the Contractor will repair or replace same within five (5) days of receipt of notice from the County Engineer. If the Contractor refuses or neglects to do such Work in the time specified, the County Engineer may have the Work done by others and the Contractor or his Surety thereof will pay the cost.

The Contractor will furnish the County a Maintenance Bond for a percentage of the final adjusted contract price, as stated above. The one (1) year period will start the day of Final Completion of Project by the County. Final payment is conditional on the receipt of a maintenance bond in a form acceptable to County Counsel.

16. TRAFFIC AND STREET MAINTENANCE

The Work must be started and performed by the Contractor in such a manner as to minimize delays to the traveling public. It must be completed in a timely fashion, with little or no inconvenience to traffic and pedestrians, where such inconvenience may be avoided.

All municipal, county, and state roadways shall remain open to traffic unless otherwise provided for in the technical specifications.

If modified traffic patterns are authorized in order to provide a safe working or traveling environment, the Contractor is responsible for providing all equipment, barrels, cones, signs, and barricades to implement the work zone and detours, unless otherwise specified in the technical specifications. All work zones and detours shall be

established in accordance with the technical plans and specifications if provided or in strict compliance with the current version of the Manual for Uniform Traffic Control Devices (MUTCD). The Contractor shall obtain approval for these work zones and detour plans from the Municipal Police or applicable police agency and the Union County Bureau of Traffic Maintenance prior to implementation.

All traffic control plans shall provide for safe movement of vehicular, bicycle, and pedestrian traffic. Particular attention shall be given to requirements of the Americans with Disabilities Act.

No portion of any street or alleyway may be used for the storage of any materials or equipment without the approval of the Municipal Police or other applicable police agency. Sidewalks, gutters, drains, fire hydrants and private drives shall be maintained for their intended use unless specifically approved by the County Engineer.

Upon suspension of Work, at the end of the day or for protracted periods, the Contractor shall remove all rubbish and materials from the Work site to the approved storage/staging location. All road cuts, saw cuts, and trenches that may pose hazard to vehicular, pedestrian, or bicycle traffic, to include handicapped users, shall be filled to the surface of the roadway or sidewalk. At no time will steel plates or settled trenches be allowed at the daily suspension of Work, unless specifically approved by the County Engineer.

Use of Traffic Control Officers shall be determined by the County in accordance with the provisions of N.J.S.A. 40A:11-23.1(c). If applicable to the Project, the County shall have provided an allowance for same as set forth in the Bid Form.

With respect to pedestrian traffic, the Contractor shall install signs restricting access of the general public and, as necessary, Union County employees to the area of construction. The Contractor shall provide safe access to required areas and place physical barriers to restricted areas. These barriers may range from caution tape to actual barriers, at the direction of the County Engineer.

17. CONTRACTOR'S EMPLOYEES

The Contractor must employ only suitable and competent labor in the Work, and must remove from the Work any incompetent, unsuitable, or disorderly person upon complaint from the County Engineer.

The parties to any contract resulting from this proposal do hereby agree that the provisions of N.J.S.A. 10:2-1 through 10:2-4 (discrimination in employment on public works contracts): 34:11-56.25 et seq. (payment of prevailing rate of wages determined pursuant to N.J.S.A. 34:11-56.30 by the Commissioner), and the Rules and Regulations

promulgated pursuant thereto, are hereby made a part of any contract and are binding upon them.

There will be no discrimination against any employee who is employed in the Work to be covered by any contract resulting from this bid because of age, race, creed, color, national origin, ancestry, marital status or sex.

Any person, firm, or corporation violating the provisions of this Section will be deemed and judged a disorderly person.

18. OWNERSHIP DISCLOSURES REQUIRED

Pursuant to P.L. 1977, N.J.S.A. 52:25-24.2, the Bidder shall submit with its Bid, or prior to receipt of bids, a statement setting forth the names and addresses of all stockholders in the corporation or partnership bidding who own ten percent (10%) or greater interest therein. (See forms attached)

19. NON-COLLUSION AFFIDAVIT

The Bidder shall submit with its bid either the attached completed "Non-Collusion Affidavit" or a statement of non-collusion with verbiage similar to same.

20. EQUAL EMPLOYMENT OPPORTUNITY COMPLIANCES

The successful bidder shall be required to complete and submit an Initial Project Workforce Report, New Jersey Department of Treasury Form AA-201, upon notification of award. Failure to submit this completed form may result in the Contract being terminated.

The successful bidder shall also be required to submit a copy of its Monthly Project Workforce Report, New Jersey Department of Treasury Form AA-202, to the New Jersey Department of Treasury's Division of Public Contracts Equal Employment Opportunity Compliance and to the Board.

21. COMPLIANCE WITH NEW JERSEY PREVAILING WAGE ACT

The County of Union, in order to fulfill the requirements of N.J.S.A. 34:11-56.25 et seq, requires that the following additional conditions be strictly followed. The bidders represent that he is not listed or is not on record in the Office of the Commissioner or the Department of Labor and Industry as one who failed to pay prevailing wages in accordance with the provisions of this Act. The bidder agrees to the inclusion of a contract provision upon award which specifically requires said Contractor to fully comply with each and all of the requirements of the aforesaid Act as it relates to prevailing rates

of wages on public contracts as set forth in the New Jersey Prevailing Wage Act, P.L. 1963, Chapter 150 and P.L. 1974, Chapter 64.

A Copy of the Prevailing Wage Rates is attached for your reference. Applicable rates are those wages and fringe benefit rates in effect on the date the contract is awarded. All predetermined rate increases listed at the time the contract award must also be paid, beginning on the dates specified. Rates may change between the time of issuance of this determination and the award of the public works contract. Therefore, prior to the award of the contract, verification must be made with the Public Contracts section, to insure that the rates contained in this determination are still prevailing.

The Contractor agrees to abide and be bound by each and all of the said statutory provisions with respect to the payment of prevailing rates of wages, and acknowledges that the County reserves the right to terminate the Contractor's (or his subcontractors') right to proceed with the scope of Work, or such portion thereof that relates to the failure to pay prevailing rates of wages. In such event or under the terms of N.J.S.A. 34:11-56.27, the Contractor and his surety will be liable to the County of Union for any excess costs occasioned by such a violation.

The Contractor or subcontractors for this Project will post the Prevailing Wage Rates for each craft and classification involved as determined by the Commissioner of Labor and Industry, including the effective date of any changes thereof, in prominent and easily accessible places at the site of the Work or at such place or places as are used by them to pay workmen their wages.

The County of Union requires a copy of payroll records from the Contractor and subcontractors. Payroll records shall be submitted with each voucher request for payment. Prevailing wage rates may be obtained from the New Jersey Labor, Division of Workplace Standards, Public Contracts Section, (609-292-2259).

In addition to compliance with the New Jersey Prevailing Wage Act, the County requires compliance with procedures established by Resolution No. 2014-0408 adopted by the Union County Board of Chosen Freeholders on May 8, 2014. The resolution is furnished in Section 51 of these General Specifications.

UNION LABOR IS PREFERRED ON ALL COUNTY WORK

The foregoing reference to specific laws will not be deemed to be a limitation of obligation of the Contractor to perform his obligations in full compliance with the provisions and requirements of all federal and state statues and local ordinances applicable to the Work to be done under the contract.

It is agreed and understood that any contracts and/or orders placed as a result of this proposal will be governed and construed and the rights and obligations of the

parties hereto will be determined in accordance with the laws of the State of New Jersey.

Upon completion of the Work, the Contractor will furnish a Certification of Compliance with the New Jersey Prevailing Wage Act. The certificate in a form acceptable to County Counsel is a condition of the final payment. (See form attached)

22. BRAND NAME OR EQUAL

When the Specifications, Forms, and other Contract Documents use “brand name or equivalent” or similar language, the listed brand name shall serve as a reference or point of comparison for the functional or operational characteristic desired for the goods or services being requested. Where a bidder attempts to submit an equivalent product for a brand name, it shall be the responsibility of the bidder to fully describe and document the product to be provided with the bid in order to establish the equivalence claim.

- A. If the Bidder proposes to offer substitute goods as an equal to those specified herein, the bidder shall so indicate with the Bid Proposal. For the purposes of this paragraph, a proposed item shall be considered equal to goods specified herein if:
 - 1. The County, in its sole discretion, determines that: (i) the goods conform substantially, even with deviations, to the brand name goods specified herein; (ii) the goods are equal to or greater than the brand name goods specified herein in terms of quality, durability, functionality, appearance, strength and design; (iii) the goods are capable, at least as well as the brand name goods specified herein, or performing with existing equipment; and (iv) the goods do not cost the County more than the brand name goods specified herein costs the County.

- B. To offer substitute goods as an equal to those specified herein, it is necessary that:
 - 1. The Bidder submits sufficient information with its bid to permit the County to determine that the goods are equivalent to the brand name goods specified herein, including, but not necessarily limited to the brand, catalog number and specifications/data sheets;
 - 2. The Bidder fully identifies and describes the variations of the goods from the brand name goods specified herein

on a separate sheet that is to be submitted with the bid proposal. Bidder's literature WILL NOT suffice in explaining exceptions to these specifications.

3. The Bidder certifies that the goods (i) are similar in substance to the brand name goods specified, and (ii) are suited to the same use as the item specified;
- C. The County shall be allowed a reasonable time within which to evaluate the Bidder's proposal to offer substitute goods as an equal to those specified herein. The County shall be the sole judge of acceptability. No "or-equal" goods shall be ordered, delivered, assembled, set-up or utilized until the County's evaluation is complete. The County's determination as to equivalency shall be deemed final and absolute.

In the event the Bidder does not provide sufficient supporting documentation with the bid, it will be presumed and required that the brand name goods and services as described in the specifications will be provided.

23. LINES AND GRADES

Normally, horizontal and vertical control points will be provided in the technical specifications. All other surveying will be the responsibility of the Contractor unless otherwise noted.

24. NUMBER OF WORKING DAYS

In accordance with N.J.S.A. 40A:11-17, the Work for the within Project shall be completed as specified on the Time of Completion Form. See form attached

There shall be taken a deduction from the contract price, or any wages paid by the County, to any inspector(s) necessarily employed by it on the Work, for any number of days in excess of the number allowed in the specifications.

25. PROMPT PAYMENT OF CONSTRUCTION CONTRACTS (NJ Prompt Payment Act)

Pursuant to N.J.S.A. 2A:30A-1 et seq., payment to the Contractor, other than for Work done pursuant to a contact allowance, where applicable, shall be processed and paid as follows:

1. All contractor bills shall be either approved for payment, or notice provided as to why the bill or any portion of it will not be approved by the representative(s) of the governing body no later than the

public meeting following 20 calendar days of the billing date as defined in the statute.

2. If the billing is approved, said bill shall be paid in the payment cycle following the meeting.

26. STOPPING WORK ON ACCOUNT OF BAD WEATHER

Work must only be performed in weather suitable for the type of construction planned or underway. Extremes in temperature, humidity, precipitation, evaporation, etc. can detrimentally affect the constructed product. Refer to the Standard and Technical Specifications for specific items.

27. ACCESS FOR OTHER CONTRACTORS

The Contractor for this Work will give proper access to other contractors who may be employed upon the Project and must not hinder or delay unnecessarily any Work that may be progressing under other contracts.

28. CONDEMNED MATERIALS AND WORK

Any materials and or part of the Work that may be condemned by the County Engineer will be removed and replaced by the Contractor or otherwise rectified, as may be directed by the County Engineer. No payment will be made upon the Work until such faulty work has been made good as may be directed. In the event the Contractor refuses or neglects to make good such faulty work, he will be deemed to have abandoned the contract and proceedings may be taken against him as provided herein.

29. STORAGE

In the event that it is necessary for the Contractor to stockpile or store materials or equipment on the job site, the Contractor shall inform the County of such necessity and the County may offer available space, if any, for storage of such materials or equipment. The Contractor shall use said space only for such purpose. Any and all materials which may be stored in such space or which may be brought onto the job site at any time by the Contractor will be at the Contractor's sole risk. The County will not be responsible for loss of or damage to said materials or equipment for any cause whatsoever. The Contractor shall take necessary measures to protect any such storage area and shall be responsible for any and all damages.

30. FINAL CLEAN UP

Upon completion of the Work, the Contractor will remove all equipment, unused materials, rubbish, etc., and will repair, or replace in an a manner acceptable to the

County Engineer, all areas that may have been damaged in the prosecution of the Work. Same shall be a condition precedent to final payment. Should said Contractor fail to comply with this requirement, the County shall undertake the clean-up with its own forces and charge the cost of same against the Contractor's contract balance.

31. SUB-LETTING OF WORK

Except for the List of Subcontractors, pursuant to N.J.S.A. 40A:11-16 (See form attached), no portion of the Work will be sublet by the Contractor to any other entities, except with the consent of the County Engineer. A complete list of subcontractors must be submitted to the County Engineer at the preconstruction meeting. If the job does not warrant a preconstruction meeting, the Contractor must submit such list prior to the start of Work.

All Subcontractors will be subject to N.J.S.A. 34:11-56 et al.

N.J.S.A. 40A:11-16 requires the bidder to list in the bid sheets the name or names of all subcontractors involved in the following types of Work: plumbing and gas fitting and all kindred work, steam and hot water heating, ventilating apparatus, steam power plants and kindred work, electrical work, ornamental iron work, and structural steel. In addition, the County may require the identification of specific additional subcontractors. If these trades are expected to be part of the contract, such subcontractors should be listed on the "Subcontractor Identification Statement List of Subcontractors" and Bidder shall certify same on the accompanying sheet titled "Subcontractor Identification Certification". (See forms attached) **Bidder's failure to submit these two forms shall be considered a material defect and result in rejection of Bidder's bid.** Substitutions of any listed subcontractors pursuant to N.J.S.A. 40A:11-16 will not be permitted except with the consent of the County Engineer.

32. SAFETY

The Contractor shall observe all rules and regulations of the Federal, State, and local health officials. Attention is directed to Federal, State, and local laws, rules, and regulations concerning construction safety and health standards. The Contractor shall not require any worker to work in surroundings or under conditions that are unsanitary, hazardous, or dangerous to the worker's health or safety.

The Contractor shall admit to the site, without delay and without the presentation of an inspection warrant, any inspector of OSHA or other legally responsible agency involved in safety and health administration upon presentation of proper credentials.

The Contractor shall make available to the Contractor's employees, subcontractors, the County Engineer, and the public, all information pursuant to OSHA 29 CFR Part 1926.59 of The Hazard Communication Standard 29 CFR 1910.1200, and shall also maintain a file on each job site containing all Material Safety Data Sheets (MSDS) for

products in use at the Project. These Material Safety Data Sheets shall be made available to the Engineer upon request.

The Contractor shall at all times conduct the Work to provide for the safety and convenience of the general public and protection of persons and property. The safety provisions of applicable laws, OSHA regulations, building and construction codes, and the rules and regulations of the New Jersey Department of Labor and Workforce Development and Commerce shall be observed.

33. QUALITY, SAFETY AND PERFORMANCE STANDARDS

All goods and services must be constructed and provided with the highest quality materials and workmanship. It is the intent of these specifications that only equipment equal to, or exceeding, the standard specified will be acceptable in order to protect the safety of the occupants of the Building.

34. MATTERS NOT MENTIONED IN CONTRACT DOCUMENTS

Any Work, material, or method, not specifically described in these specifications, but shown upon the plans of the Work, will be carried out as shown on said plan.

35. PERMITS

The Contractor will obtain all necessary permits required by law and provide the County with necessary approvals prior to commencement of permitted Work.

36. CONTRACTOR TO PROVIDE PROOF OF PAYMENT

Upon the completion of the Work, the Contractor will furnish a General Release as proof that all claims for labor, materials, etc., have been settled by the Contractor. The General Release, in a form acceptable to County Counsel, is a condition of final payment.

37. CHANGE ORDERS

Change Order Procedures shall comply with N.J.A.C. 5:30-11.1 et seq., "Change Orders and Open End Contracts" and subsequent provisions of the New Jersey Administrative Code.

38. SUPPLEMENTAL WORK

In case any supplemental work is necessary, it will be performed by the Contractor at a price fixed by agreement between the Contractor and the County Engineer and approved by the County as specified in Section 36. The Contractor will do no supplemental work on any character, for which the Contractor will demand pay, except upon the written order of the County.

39. FORM OF CONTRACT

The Contract will be subject to all statutory provisions on the matter of Public Works, Public Contracts, The Law Against Discrimination, the Laws Governing Affirmative Action and Prevailing Rates of Wages under the laws of New Jersey.

The Agreements shall be executed by both parties not later than twenty-one (21) days from the date of the award by the County (Sundays and holidays excluded); however, such time frame may be extended by agreement of the parties.

40. PROGRESS PAYMENTS

Monthly progress payments will be made based on the value of labor and materials incorporated in the Work and of materials suitably stored at the site. An itemized schedule of values shall be submitted with each Application for Payment.

(Refer to the Owner/Contractor Agreement for Retainage and other conditions pertaining to payment and the application of N.J.S.A. 2A:30A-1 et seq.)

All Applications for Payment shall be accompanied by paid invoices for materials incorporated in the Work and for materials suitably stored at the site, and affidavit(s) by Subcontractors whose Work was included in the next to the last application to the effect such Work and such materials have been paid for.

No payment shall be made without Contractor having provided all submittals set forth in this Section, and the approval of same by the County.

For contracts exceeding \$100,000.00, monthly payments will be made on the Work to the extent of 98% of the value of the Work done which is considered to be retainage.

For contracts less than \$100,000.00, monthly payments will be on the Work to the extent of 90% of the value of the Work done. In lieu of the retainage, the Contractor will, at his option, deposit with the County Counsel negotiable bearer bonds of the State of New Jersey or any political subdivision thereof, equal to the amount otherwise withheld as retainage.

When the Project is completed, the final cost of the Project will be based on actual quantities of authorized Work done under each item scheduled in the bidding sheet and approved Change Orders, if any. The money due to the Contractor as determined by said final certificate after deduction of previous monthly payments on account, will be paid to the Contractor in accordance with the terms of the contract dealing with Prompt Payment, providing, however that before such final payment is

made, all outstanding claims against the Contractor must be satisfied. Before final payment is released, the Contractor must furnish: **a)** Maintenance Bond (see Section 6 of these general specifications); **b)** Certification of Compliance, New Jersey Prevailing Wage Act (see Sections 21 and 51); and **c)** General Release (see Section 36) in a form satisfactory to County Counsel; **d)** complete set of as-built plans in the latest AutoCad on compact disc; and **e)** a complete set of in-progress photos in jpg, jpeg, or bmp digital format on a compact disc.

41. INSPECTION

The Work must be done in accordance with the plans and specifications, and will be inspected by the County Engineer. An inspector may be placed upon the Work at any time by the County Engineer to see that the plans, specifications, and instructions of the County Engineer are carried out. In connection herewith, bidders are referred to N.J.S.A. 40A:11-17.

42. DAMAGES

The Contractor will be held responsible for all damages that may occur to Work, or to persons or property by reason of the nature of the Work or from the elements, or by reason of inadequate protection of the Work, or from any carelessness or negligence on his part or on the part of his employees. The County will withhold payments on the Work until all suits or claims for damages sustained on, or by reason of, this Work will have been settled by the Contractor.

The construction and final completion of this Work will be guaranteed by the Contractor. Any damages that may be done to the Work or any part thereof, by the elements or otherwise, during its construction, will be made good by the Contractor.

43. LIQUIDATED DAMAGES

If the Project is not completed within the time specified herein or within such further time as may have been granted by the County Engineer, then the Contractor hereby agrees to pay to the County as liquidated damages, but not as a penalty, \$1,000.00 per day for each and every calendar day that he is in default on time to complete the Work. The said sum will be deducted from moneys due the Contractor and if the damages exceed this amount, then the Contractor or his Surety Company will pay the excess. These damages may be waived at the option of the County.

44. AFFIRMATIVE ACTION REQUIREMENTS

EXHIBIT B (Revised 4/10)

MANDATORY EQUAL EMPLOYMENT OPPORTUNITY LANGUAGE N.J.S.A. 10:5-31 et seq. (P.L. 1975, C. 127) N.J.A.C. 17:27

CONSTRUCTION CONTRACTS

During the performance of this contract, the contractor agrees as follows:

The contractor or subcontractor, where applicable, will not discriminate against any employee or applicant for employment because of age, race, creed, color, national origin, ancestry, marital status, affectional or sexual orientation, gender identity or expression, disability, nationality or sex. Except with respect to affectional or sexual orientation and gender identity or expression, the contractor will ensure that equal employment opportunity is afforded to such applicants in recruitment and employment, and that employees are treated during employment, without regard to their age, race, creed, color, national origin, ancestry, marital status, affectional or sexual orientation, gender identity or expression, disability, nationality or sex. Such equal employment opportunity shall include, but not be limited to the following: employment, up-grading, demotion, or transfer; recruitment or recruitment advertising; layoff or termination; rates of pay or other forms of compensation; and selection for training, including apprenticeship. The contractor agrees to post in conspicuous places, available to employees and applicants for employment, notices to be provided by the Public Agency Compliance Officer setting forth provisions of this nondiscrimination clause.

The contractor or subcontractor, where applicable will, in all solicitations or advertisements for employees placed by or on behalf of the contractor, state that all qualified applicants will receive consideration for employment without regard to age, race, creed, color, national origin, ancestry, marital status, affectional or sexual orientation, gender identity or expression, disability, nationality or sex.

The contractor or subcontractor will send to each labor union, with which it has a collective bargaining agreement, a notice, to be provided by the agency contracting officer, advising the labor union or workers' representative of the contractor's commitments under this act and shall post copies of the notice in conspicuous places available to employees and applicants for employment.

The contractor or subcontractor, where applicable, agrees to comply with any regulations promulgated by the Treasurer, pursuant to N.J.S.A. 10:5-31 et seq., as amended and supplemented from time to time and the Americans with Disabilities Act.

When hiring or scheduling workers in each construction trade, the contractor or subcontractor agrees to make good faith efforts to employ minority and women workers in each construction trade consistent with the targeted employment goal prescribed by N.J.A.C. 17:27-7.2; provided, however, that the Division may, in its discretion, exempt a contractor or subcontractor from

compliance with the good faith procedures prescribed by the following provisions, A, B and C, as long as the Division is satisfied that the contractor or subcontractor is employing workers provided by a union which provides evidence, in accordance with standards prescribed by the Division, that its percentage of active "card carrying" members who are minority and women workers is equal to or greater than the targeted employment goal established in accordance with N.J.A.C. 17:27-7.2. The contractor or subcontractor agrees that a good faith effort shall include compliance with the following procedures:

(A) If the contractor or subcontractor has a referral agreement or arrangement with a union for a construction trade, the contractor or subcontractor shall, within three business days of the contract award, seek assurances from the union that it will cooperate with the contractor or subcontractor as it fulfills its affirmative action obligations under this contract and in accordance with the rules promulgated by the Treasurer pursuant to N.J.S.A. 10:5-31 et. seq., as supplemented and amended from time to time and the Americans with Disabilities Act. If the contractor or subcontractor is unable to obtain said assurances from the construction trade union at least five business days prior to the commencement of construction work, the contractor or subcontractor agrees to afford equal employment opportunities minority and women workers directly, consistent with this chapter. If the contractor's or subcontractor's prior experience with a construction trade union, regardless of whether the union has provided said assurances, indicates a significant possibility that the trade union will not refer sufficient minority and women workers consistent with affording equal employment opportunities as specified in this chapter, the contractor or subcontractor agrees to be prepared to provide such opportunities to minority and women workers directly, consistent with this chapter, by complying with the hiring or scheduling procedures prescribed under (B) below; and the contractor or subcontractor further agrees to take said action immediately if it determines that the union is not referring minority and women workers consistent with the equal employment opportunity goals set forth in this chapter.

(B) If good faith efforts to meet targeted employment goals have not or cannot be met for each construction trade by adhering to the procedures of (A) above, or if the contractor does not have a referral agreement or arrangement with a union for a construction trade, the contractor or subcontractor agrees to take the following actions:

(1) To notify the public agency compliance officer, the Division, and minority and women referral organizations listed by the Division pursuant to N.J.A.C. 17:27-5.3, of its workforce needs, and request referral of minority and women workers;

(2) To notify any minority and women workers who have been listed with it as awaiting available vacancies;

(3) Prior to commencement of work, to request that the local construction trade union refer minority and women workers to fill job openings, provided the contractor or subcontractor has a referral agreement or arrangement with a union for the construction trade;

(4) To leave standing requests for additional referral to minority and women workers with the local construction trade union, provided the contractor or subcontractor has a referral agreement or arrangement with a union for the construction trade, the State Training and Employment Service and other approved referral sources in the area;

(5) If it is necessary to lay off some of the workers in a given trade on the construction site, layoffs shall be conducted in compliance with the equal employment opportunity and non-discrimination standards set forth in this regulation, as well as with applicable Federal and State court decisions;

(6) To adhere to the following procedure when minority and women workers apply or are referred to the contractor or subcontractor:

(i) The contractor or subcontractor shall interview the referred minority or women worker.

(ii) If said individuals have never previously received any document or certification signifying a level of qualification lower than that required in order to perform the work of the construction trade, the contractor or subcontractor shall in good faith determine the qualifications of such individuals. The contractor or subcontractor shall hire or schedule those individuals who satisfy appropriate qualification standards in conformity with the equal employment opportunity and non-discrimination principles set forth in this chapter. However, a contractor or subcontractor shall determine that the individual at least possesses the requisite skills, and experience recognized by a union, apprentice program or a referral agency, provided the referral agency is acceptable to the Division. If necessary, the contractor or subcontractor shall hire or schedule minority and women workers who qualify as trainees pursuant to these rules. All of the requirements, however, are limited by the provisions of (C) below.

(iii) The name of any interested women or minority individual shall be maintained on a waiting list, and shall be considered for employment as described in (i) above, whenever vacancies occur. At the request of the Division, the contractor or subcontractor shall provide evidence of its good faith efforts to employ women and minorities from the list to fill vacancies.

(iv) If, for any reason, said contractor or subcontractor determines that a minority individual or a woman is not qualified or if the individual qualifies as an advanced trainee or apprentice, the contractor or subcontractor shall inform the individual in writing of the reasons for the determination, maintain a copy of the determination in its files, and send a copy to the public agency compliance officer and to the Division.

(7) To keep a complete and accurate record of all requests made for the referral of workers in any trade covered by the contract, on forms made available by the Division and submitted promptly to the Division upon request.

(C) The contractor or subcontractor agrees that nothing contained in (B) above shall preclude the contractor or subcontractor from complying with the union hiring hall or apprenticeship policies in any applicable collective bargaining agreement or union hiring hall arrangement, and, where required by custom or agreement, it shall send journeymen and trainees to the union for referral, or to the apprenticeship program for admission, pursuant to such agreement or arrangement. However, where the practices of a union or apprenticeship program will result in the exclusion of minorities and women or the failure to refer minorities and women consistent with the targeted county employment goal, the contractor or subcontractor shall consider for employment persons referred pursuant to (B) above without regard to such agreement or arrangement; provided further, however, that the contractor or subcontractor shall

not be required to employ women and minority advanced trainees and trainees in numbers which result in the employment of advanced trainees and trainees as a percentage of the total workforce for the construction trade, which percentage significantly exceeds the apprentice to journey worker ratio specified in the applicable collective bargaining agreement, or in the absence of a collective bargaining agreement, exceeds the ratio established by practice in the area for said construction trade. Also, the contractor or subcontractor agrees that, in implementing the procedures of (B) above, it shall, where applicable, employ minority and women workers residing within the geographical jurisdiction of the union.

After notification of award, but prior to signing a construction contract, the contractor shall submit to the public agency compliance officer and the Division an initial project workforce report (Form AA 201) electronically provided to the public agency by the Division, through its website, for distribution to and completion by the contractor, in accordance with N.J.A.C. 17:27-7. The contractor also agrees to submit a copy of the Monthly Project Workforce Report once a month thereafter for the duration of this contract to the Division and to the public agency compliance officer.

The contractor agrees to cooperate with the public agency in the payment of budgeted funds, as is necessary, for on-the-job and/or off-the-job programs for outreach and training of minorities and women.

(D) The contractor and its subcontractors shall furnish such reports or other documents to the Division of Public Contracts Equal Employment Opportunity Compliance as may be requested by the Division from time to time in order to carry out the purposes of these regulations, and public agencies shall furnish such information as may be requested by the Division of Public Contracts Equal Employment Opportunity Compliance for conducting a compliance investigation pursuant to **Subchapter 10 of the Administrative Code (NJAC 17:27)**.

[REMAINDER OF PAGE INTENTIONALLY LEFT BLANK]

45. INVESTMENT ACTIVITIES IN IRAN

Pursuant to P.L. 2012, c.25, codified as N.J.S.A. 2:32-55 et seq., prohibits State and local public contracts with persons or entities engaging in certain investment activities in energy or finance sectors of Iran.

46. COMPLIANCE WITH THE PUBLIC WORKS CONTRACTOR REGISTRATION ACT - (N.J.S.A. 34:11-56.48 et. seq.)

Pursuant to the above-referenced law, Bidders are required to be registered with the New Jersey Department of Labor and Workforce Development and to possess a current certificate by said Department indicating compliance with the Act prior to the time and date that bids are received. Bidders are notified of this requirement of their compliance. Such certificates or applications shall also be provided for each Subcontractor furnishing plumbing and gas fitting, steam and hot water heating and ventilating apparatus, and all kindred work, steam power plants and kindred work, electrical work, structural steel and ornamental iron work, and such other subcontractors as the specifications require relative to prior identification.

47. UTILITIES

Attention of the bidder is directed to the fact that the approximate locations of known utility structures and facilities that may be encountered within and adjacent to the limits of the Work are shown on the plans and described herein. The accuracy and completeness of this information is not guaranteed by the County Engineer and the bidder is advised to ascertain for himself all the facts concerning the location of these and other utilities.

The Contractor will not proceed with his Work until he has made diligent inquiries of all public utility and municipal officials to determine the exact location of all underground structures and pipes within the site of the Project. The Contractor will notify utility owners not less than ten (10) days in advance of the time he proposes to perform any Work that will endanger or affect their facilities in compliance with **New Jersey One-Call**. In excavating in any part of the Work, care must be taken not to remove or damage any gas, water, sewer, or other pipe, conduit, or structure, - public or private - without the concurrence of the owner and the County Engineer. The Contractor will, at his own expense, shore up, secure and maintain a continuous flow in such structures, and will keep them in repair until final acceptance of the Work.

When pipes or other structures are encountered or when the removal, relocation or protection of these utilities are necessary in carrying out the Project as planned, the Contractor will cooperate with the owner of said utilities and will permit the owners or their agents access to the site of the Work in order to relocate or protect their facilities

and not hinder or delay unnecessarily the Work of the owners in moving same. No extra allowance of payment will be made to the Contractor for the use of any materials, equipment, etc., or for the performance of any Work in connection with the moving of said structures unless the Contractor is specifically ordered by the County Engineer to furnish such materials, equipment, or services. If directed by the County Engineer to do any Work or furnish any materials or equipment, payment will be allowed the Contractor in accordance with the unit prices bid for such Work, or, if such items are not scheduled in the proposal, such Work shall be allowed "Supplemental Work" as provided in Section 39 of these general specifications. The corporations, companies, agencies or municipalities owning or controlling the utilities, and the name, and telephone numbers are listed in the beginning of the Technical Specifications.

48. MATERIAL COMPLIANCE AND SHOP DRAWINGS

The Contractor will require the manufacturer or supplier to furnish three (3) copies of Certification of Compliance with each delivery of materials, components and manufactured items for the Project. Two (2) copies will be furnished to the County Engineer; one copy will be retained by the Contractor. Certificates of Compliance will contain the following information:

1. Project to which material is consigned;
2. Name of the Contractor to which the material is supplied;
3. Kind of material supplied;
4. Quantity of material represented by the Certificate;
5. Means of identifying the consignment, such as label marking, seal number, etc.;
6. Date and method of shipment;
7. That the material is in conformity with the pertinent specifications stated in the certificate; and
8. Signature of a person having legal authority to bind the supplier.

The Contractor will submit to the County Engineer for his approval five (5) copies of complete and fully detailed shop or working drawings for those items listed in the beginning of the technical specifications.

Each drawing will identify the name of the job, location and Contractor.

All drawings will be approved in accordance with the standard specifications. Refer to the Technical Specifications for specific items.

All materials or articles used in the Work will be of American manufacture, insofar as same are available, in conformance with N.J.S.A. 40A:11-18.

49. PRECONSTRUCTION

In order to provide full coordination of this Project among the parties concerned, the County Engineer will arrange for a preconstruction meeting between the Contractor, County Engineer and other interested parties as soon as possible after the contract is executed. At this meeting the Contractor will present his proposed schedule of Work which shall be subject to review and approval of the County through its designated representatives.

50. DISPUTES UNDER THE CONTRACT

A dispute arising under the Contract shall be submitted in writing to the County Engineer with all facts and supporting data. The County Engineer will review the dispute and issue his decision or request additional facts or documentation after which he will render his decision.

In the event the dispute is not then resolved, the matter shall, pursuant to law, be submitted to mediation before being submitted to a court of competent jurisdiction venued in Union County.

The County Engineer will notify the County Counsel when a matter is to be submitted to mediation. The County Counsel will communicate with the parties and inform them of the procedures to be followed in making such a submission.

[REMAINDER OF PAGE INTENTIONALLY LEFT BLANK]

51. CONTRACTOR BUSINESS REGISTRATION CERTIFICATE New Mandatory Requirement -Effective 1/18/2010

The recently enacted **P.L. 2009, c.315**, requires that effective January 18, 2010; a contracting agency must receive proof of the bidder's business registration prior to the award of a contract. However, the proof must show that the bidder was in fact registered with the State of New Jersey Department of the Treasury, Division of Revenue and obtained the business registration prior to the receipt of bids.

If subcontractors are named on the bid, proof of the business registration for each subcontractor must be provided prior to the award of bid. Similarly to the bidder, the proof must show that each subcontractor was registered with the State of New Jersey Department of the Treasury, Division of Revenue and obtained the business registration prior to the receipt of bids.

Proof of business registration shall be

- A copy of a Business Registration Certificate issued by the Department of the Treasury, Division of Revenue; or
- A copy of the web version provided by the NJ Division of Revenue, or

Register online at <http://www.state.nj.us/treasury/revenue/busregcert.htm>. Click the "online" link and then select "Register for Tax and Employer Purposes or call the Division at 609-292-1730.

Note: A NJ Certificate of Authority is not acceptable.

FAILURE to submit proof of registration of the bidder or any subcontractor named on the bid prior to the award of contract shall be cause to reject the bid.

FAILURE of the bidder or any subcontractor named on the bid to be registered prior to the receipt of bids is cause for a **MANDATORY REJECTION** of bids. (A NON-WAIVABLE DEFECT). This covers construction Work as well as non-construction bids.

IN ADDITION:

N.J.S.A. 52:32-44 imposes the following requirements on Contractors and all subcontractors that knowingly provide goods or perform services for a Contractor fulfilling this contract:

- 1) the Contractor shall provide written notice to its subcontractors and suppliers to submit proof of business registration to the Contractor;
- 2) subcontractors through all tiers of a project must provide written notice to their subcontractors and suppliers to submit proof of business registration and subcontractors shall collect such proofs of business registration and maintain them on file;

- 3) prior to receipt of final payment from a contracting agency, the Contractor must submit to the contacting agency an accurate list of all subcontractors and suppliers or attest that none was used; and,
- 4) during the term of this contract, the Contractor and its affiliates shall collect and remit, and shall notify all subcontractors and their affiliates that they must collect and remit, to the Director, New Jersey Division of Taxation, the use tax due pursuant to the Sales and Use Tax Act, (*N.J.S.A. 54:32B-1 et seq.*) on all sales of tangible personal property delivered into this State.

A Contractor, subcontractor or supplier who fails to provide proof of business registration or provides false business registration information shall be liable to a penalty of \$25 for each day of violation, not to exceed \$50,000 for each business registration copy not properly provided or maintained under a contract with a contracting agency. Information on the law and its requirements are available by calling (609) 292-9292.

[REMAINDER OF PAGE INTENTIONALLY LEFT BLANK]

52. BID PROTEST – LEGAL FEES AND COSTS

In the event a Bidder unsuccessfully challenges a Bid Submission by filing an action in a court of law concerning same, said Bidder shall be responsible for payment of reasonable legal costs and fees incurred by the County relating to said protest.

53. AMERICAN GOODS AND PRODUCTS WHERE POSSIBLE

Bidder shall comply with the requirements of N.J.S.A. 40A:11-18 and use only manufactured and farm products of the United States, wherever available, for the Project.

54. NEW JERSEY PAY-TO-PLAY REQUIREMENTS

This Contract is required by law to be publicly advertised for bids. As such, lists of political contributions pursuant to N.J.S.A. 19:44A-1 et seq. are NOT REQUIRED to be provided with the bids.

55. STATEMENT OF EQUIPMENT TO BE USED IN CONSTRUCTION

Pursuant to N.J.S.A. 40A:11-20 entitled Certificate of Bidder Showing Ability to Perform Contract, the County requires a Certification from all bidders submitting a bid showing that the Bidder owns, leases, or controls all necessary equipment required by the Project Plans and Specifications. All bidders shall provide this information at the time of the bid opening using the attached form entitled, "CERTIFICATE OF BIDDER SHOWING ABILITY TO PERFORM CONTRACT".

If the Bidder is not the actual owner of the equipment, it shall state the source from which the equipment will be obtained and shall attach a certificate from the owner or person in control of the equipment demonstrating that the equipment owner has granted the Bidder control of the requisite equipment during such time as may be necessary for completion of the portion of the contract for which the equipment is necessary.

56. NEW JERSEY SALES AND USE TAX REQUIREMENTS,

Contractors are required to comply with the following:

New Jersey Sales and Use Tax Requirements: All contractors with subcontractors, or any of their affiliates, who enter into contracts for the provision of goods or services with or for New Jersey local government entities, are required to collect and remit to the New Jersey Director of Taxation in the Department of the Treasury the use tax due on all of their sales of tangible personal property delivered into the State of New Jersey pursuant to the "Sales and Use Tax Act," (N.J.S.A. 54:32B-1 et seq.),

regardless of whether the tangible personal property is intended for a contract with the contracting agency. This tax shall be remitted for the term of the Contract.

For purposes herein "affiliate" shall mean any entity that: (a) directly, indirectly, or constructively controls another entity, (b) is directly, indirectly, or constructively controlled by another entity, or (c) is subject to the control of a common entity. For purposes of the immediately preceding sentence, an entity controls another entity if it owns, directly or indirectly, more than fifty percent (50%) of the ownership interest in that entity. NJSA 52:32-44(g)(3).

Bidder's Name _____

EDWARD T. OATMAN
COUNTY MANAGER

LAURA M. SCUTARI, QPA, MPA
DIRECTOR / DIVISION OF PURCHASING

BID DOCUMENT SUBMISSION CHECKLIST

**ALL SIGNATURES AND SEALS SHALL BE ORIGINALS UNLESS OTHERWISE SPECIFIED
BID SHEETS SHOULD NOT BE SUBMITTED DOUBLE SIDED PAGES, (SINGLE SIDE ONLY)**

EACH BIDDER SHOULD COMPLETE THIS FORM AND INITIAL EACH ENTRY.

DATE COMPLETED: _____

**PLEASE SUBMIT BID DOCUMENTS ON SINGLE SIDED PAPER ONLY, WITH THE EXCEPTION OF
THE SURETY AND BID BOND DOCUMENTS.**

**IN ACCORDANCE WITH THE BID SPECIFICATIONS I HAVE REVIEWED, COMPLETED / EXECUTED
AND INCLUDED THE FOLLOWING FORMS:**

_____ Bid Form Page (**Signed, Dated and Bid on all alternatives applicable to the Work**).

_____ Security in the form of:

- _____ Bid bond in an amount equal to 10% of the total amount of this bid not to exceed \$20,000.00; or
- _____ Certified check or cashier's check in the amount of 10% of this bid not to exceed \$20,000.00

_____ Consent of Surety form signed by a Surety Company if the total amount of your Bid is over \$36,000.00. If your bid is accepted, the Surety Company that provided the Consent shall be required to furnish a Performance, Labor and Materials Bond in the amount of 100% of the award of the contract. The County of Union has provided its Consent of Surety form for your use. The use of this form by your Surety Company will expedite the bid review process and eliminate the possibility of having your bid rejected. If, however, you should need to use another form, please use language similar to that used on the Union County form and avoid making any additions or deletions to the Union County form language. In lieu of the Consent of Surety you may submit a Certified Check in the full amount of the bid.

_____ STATEMENT OF BIDDER OWNERSHIP. Pursuant to N.J.S.A. 52:25-24.2, which includes **BOTH** of the following documents:

- Bidder Signature Page
- Bidder Disclosure Statement (**Fill out 2 pages completely**)

_____ SUBCONTRACTOR IDENTIFICATION. Pursuant to N.J.S.A. 40A:11-16, which includes **BOTH** of the following documents:

- Subcontractor Identification Statement: List of Subcontractors (**only for certain types of work**)
- Subcontractor Identification Certification

_____ Acknowledgement of Addendum form: (**This form is to be used only when an addendum has been added to the specifications**).

_____ A copy of the State of New Jersey Department of the Treasury, Division of Revenue, **Business Registration Certificate ("BRC")** should be included with the bids as it must be received by the County prior to the award of the contract. The BRC provided must show that the Bidder was registered at the time of receipt of bids or the bid will be rejected.

_____ A copy of the State of New Jersey Department of the Treasury, Division of Revenue, **Business Registration Certificate ("BRC")** of all named or listed subcontractors (List of Subcontractors) in a Construction bid should be included with the bid as the BRC(s) must be received by the County prior to the award of the contract. Each subcontractor's certificate provided must show that the subcontractor was registered at the time of the receipt of bids or the bid will be rejected.

Bidder's Name _____

- _____ Affirmative Action Requirement
- _____ Experience Statement
- _____ Certificate of Bidder showing ability to perform Contract
- _____ Non-Collusion Affidavit – Fill out completely and notarize
- _____ Certificates from New Jersey Department of Labor and Workforce Development – Public Works Contractor Registration Act. **(Only for certain types of work)**
- _____ Federal Attachments **(If applicable)**
- _____ NJDPMC Certificate / Notice of Classification **(If applicable)**
- _____ Americans with Disabilities Act
- _____ Statement of Bidder's Qualifications
- _____ Contractor Performance Record
- _____ Affidavit Regarding List of Debarred, Suspended or Disqualified Bidders
- _____ Prior Negative Experience Questionnaire
- _____ Contractor's Certification of Compliance – New Jersey Prevailing Wage Act
- _____ Uncompleted Contracts Affidavit **(For Bidder, if applicable) MUST ALSO PROVIDE DPMC FORM 701**
- _____ Certificate of Insurance Statement
- _____ Collection of Use Tax on Sales to Local Government Statement
- _____ Time of Completion
- _____ Disclosure of Investment Activities in Iran Certification Form

I HAVE TAKEN THE FOLLOWING ACTIONS:

- _____ Visited the site and attended the Pre-Bid Meeting **(Where applicable)**
- _____ Reviewed the Contract Documents (including any permits the County or its professionals may have obtained), Work, Site, Locality, and Local Conditions and Laws and Regulations that in any manner may affect Cost, Progress, Performance or Furnishing of Work.
- _____ Reviewed Bond Requirements
- _____ Provided Proof of Compliance with New Jersey Prevailing Wage Act
- _____ Reviewed Form of Owner/Contractor Agreement and General Conditions to the Contract

**NOTE: QUESTIONS PERTAINING TO THIS BID ARE TO BE DIRECTED TO DIVISION OF ENGINEERING
AT 908-789-3675**

BIDDING DOCUMENTS

The Bidding Documents consist of the following items:

- **ADDENDA, if issued**
- **CLARIFICATIONS, if issued**
- **INSTRUCTION TO BIDDERS**
- **BID FORM**
- **SPECIFICATIONS:** **As outlined in the Table of Contents and included in the Project Manual.**
- **DRAWINGS:** **As per List of Drawings, indicated on the Project Title Sheet.**

Bidder's Name _____

BID FORM

I/We have carefully examined the plans, specifications, and advertisement for bid for the

**GALLOPING HILL G.C.
2019 IRRIGATION IMPROVEMENT PROJECT
TOWNSHIP OF KENILWORTH
COUNTY OF UNION, NEW JERSEY
BA#9-2019; Union County Engineering Project #2019-002**

that is on file in the Union County Division of Engineering. I/We have inspected the site of the work and will contract to do all the work and furnish all materials mentioned in said plans and specifications. Work will be accomplished in the manner prescribed therein.

LUMP SUM BID:

Written

Figures

BID CONTINGENCY: (To be used if and when directed by the County)

THIRTY THOUSAND DOLLARS AND NO CENTS
Written

\$30,000.00
Figures

TOTAL LUMP SUM PLUS BID CONTINGENCY AMOUNT:

Written

Figures

NOTE: Bid Contingency may include one-half of one percent of contract amount set aside for local training if and when directed by the County.

UNIT PRICE SCHEDULE

The following are unit prices for computing additions to or deletions from the contract. Unit prices below shall include all materials, related appurtenances, equipment and taxes, permit fees and labor required to install each item. Labor rate for installation shall remain consistent for the duration of the project.

<u>ITEM</u>	<u>INSTALLED UNIT PRICE</u>
Rain Bird OSM-S 8 Station Output Module	_____ /ea.
Rain Bird PAR+ES Satellite Controller w/ 72 Stations	_____ /ea.
Paige AWG #12/1 PE Wire	_____ /mlf.
Paige AWG #14/1 PE Wire	_____ /mlf.
Paige AWG #14/2 Maxi Wire	_____ /mlf.
Paige AWG #10/3 Tray Cable Power Wire	_____ /mlf.
Carson 10" Round Valve Box w/ Cover	_____ /ea.
Carson 14" Standard Valve Box w/ Cover	_____ /ea.
Paige Ground Plate Assembly w/ Powerset	_____ /ea.
Paige 5/8" x 10 Foot Ground Rod and w/ Cad Weld	_____ /ea.

Bidder's Name _____

CONSENT OF SURETY
TO ACCOMPANY PROPOSAL (BID)

_____ (hereinafter called Surety), organized and existing under the laws of the State of _____ duly authorized and qualified to transact business in the State of New Jersey, in consideration of the sum of One Dollar (\$1.00), lawful money of the United States of America, to it in hand paid, receipt whereof is hereby acknowledged, and in consideration, hereby certifies and agrees that if the contract for which the attached proposal is made be awarded to _____ (hereinafter called Contractor) for the performance of certain work and labor or the supplying of certain materials, or both, as more particularly set forth in said proposal and described for purposes of this instrument as a proposal for _____ to the COUNTY OF UNION and if Contractor shall enter into the contract, Surety will become bound as surety for its faithful performance, labor and material payment and will provide the Contractor with a performance, labor and material payment bond in the full amount of the contract price.

NOTE:
Expiration date
Needed if Annual
Surety

NAME OF INSURANCE COMPANY

ADDRESS: _____

ORIGINAL SIGNATURE
ATTORNEY-IN-FACT FOR INSURANCE CO.

NOTE: PROOF OF AUTHORITY OF OFFICERS OF SURETY COMPANY TO EXECUTE THIS DOCUMENT MUST BE SUBMITTED.

Bidder's Name _____

BIDDER SIGNATURE PAGE

THE BIDDER MUST READ THE FOLLOWING INSTRUCTIONS TO COMPLETE THIS PAGE:

1. If doing business under a **trade name, partnership or a sole proprietorship**, you must submit the bid under exact title of the trade name, partnership, or proprietorship, and the bid must be signed by either the **owner**, or a **partner** and **witnessed** by a **notary public**.
2. If a **Corporation**, the bid must be signed by the **President** or **Vice President** and **witnessed** by a **Corporate Secretary** (corporate title must be exact) and **affix corporate seal**. If a Corporate Secretary does not exist, President or Vice President's signature shall be witnessed by a Notary Public.
3. Other persons **authorized** by **corporate resolution** to execute agreements in its behalf may also sign the bid documents (pages). **Copy of a resolution must accompany the bid**.
4. The person who signs this bid form **must also** sign the **Non-Collusion Affidavit**.
5. You **cannot** witness your own signature.

NAME OF BIDDER

ADDRESS OF BIDDER

**ORIGINAL SIGNATURE
CORPORATE SECRETARY**

**PRINT NAME AND TITLE
CORPORATE SECRETARY**

TEL: _____
FAX: _____
E-Mail: _____

BY: _____
ORIGINAL SIGNATURE

Corporate Seal

PRINT OR TYPE NAME AND TITLE

WARNING: IF YOU FAIL TO FULLY, ACCURATELY, AND COMPLETELY SUPPLY THE INFORMATION REQUESTED ON THIS PAGE, YOUR BID MAY BE REJECTED.

STATEMENT OF OWNERSHIP DISCLOSURE

N.J.S.A. 52:25-24.2 (P.L. 1977, c.33, as amended by P.L. 2016, c.43)

This statement shall be completed, certified to, and included with all bid and proposal submissions. Failure to submit the required information is cause for automatic rejection of the bid or proposal.

Name of Organization: _____

Organization Address: _____

Part I Check the box that represents the type of business organization:

- Sole Proprietorship (skip Parts II and III, execute certification in Part IV)
- Non-Profit Corporation (skip Parts II and III, execute certification in Part IV)
- For-Profit Corporation (any type) Limited Liability Company (LLC)
- Partnership Limited Partnership Limited Liability Partnership (LLP)
- Other (be specific): _____

Part II

- The list below contains the names and addresses of all stockholders in the corporation who own 10 percent or more of its stock, of any class, or of all individual partners in the partnership who own a 10 percent or greater interest therein, or of all members in the limited liability company who own a 10 percent or greater interest therein, as the case may be. **(COMPLETE THE LIST BELOW IN THIS SECTION)**

OR

- No one stockholder in the corporation owns 10 percent or more of its stock, of any class, or no individual partner in the partnership owns a 10 percent or greater interest therein, or no member in the limited liability company owns a 10 percent or greater interest therein, as the case may be. **(SKIP TO PART IV)**

(Please attach additional sheets if more space is needed):

Bidder's Name _____

Name of Individual or Business Entity	Home Address (for Individuals) or Business Address

Part III DISCLOSURE OF 10% OR GREATER OWNERSHIP IN THE STOCKHOLDERS, PARTNERS OR LLC MEMBERS LISTED IN PART II

If a bidder has a direct or indirect parent entity which is publicly traded, and any person holds a 10 percent or greater beneficial interest in the publicly traded parent entity as of the last annual federal Security and Exchange Commission (SEC) or foreign equivalent filing, ownership disclosure can be met by providing links to the website(s) containing the last annual filing(s) with the federal Securities and Exchange Commission (or foreign equivalent) that contain the name and address of each person holding a 10% or greater beneficial interest in the publicly traded parent entity, along with the relevant page numbers of the filing(s) that contain the information on each such person. **Attach additional sheets if more space is needed.**

Website (URL) containing the last annual SEC (or foreign equivalent) filing	Page #'s

Please list the names and addresses of each stockholder, partner or member owning a 10 percent or greater interest in any corresponding corporation, partnership and/or limited liability company (LLC) listed in Part II **other than for any publicly traded parent entities referenced above.** The disclosure shall be continued until names and addresses of every noncorporate stockholder, and individual partner, and member exceeding the 10 percent ownership criteria established pursuant to N.J.S.A. 52:25-24.2 has been listed. **Attach additional sheets if more space is needed.**

Bidder's Name _____

Stockholder/Partner/Member and Corresponding Entity Listed in Part II	Home Address (for Individuals) or Business Address

Part IV Certification

I, being duly sworn upon my oath, hereby represent that the foregoing information and any attachments thereto to the best of my knowledge are true and complete. I acknowledge: that I am authorized to execute this certification on behalf of the bidder/proposer; that the **County of Union** is relying on the information contained herein and that I am under a continuing obligation from the date of this certification through the completion of any contracts with **County of Union** to notify the **County of Union** in writing of any changes to the information contained herein; that I am aware that it is a criminal offense to make a false statement or misrepresentation in this certification, and if I do so, I am subject to criminal prosecution under the law and that it will constitute a material breach of my agreement(s) with the, permitting the **County of Union** to declare any contract(s) resulting from this certification void and unenforceable.

Full Name (Print):		Title:	
Signature:		Date:	

SUBCONTRACTOR IDENTIFICATION STATEMENT

LIST OF SUBCONTRACTORS

This form is ONLY required for plumbing and gas fitting, steam and hot water heating and ventilating apparatus, steam power plants, electrical work, structural steel, ornamental iron work, and any other trades required to be identified by the specifications (including, but not limited, to satisfying any DPMC Classification requirements).

CHECK THIS BOX IF NONE OF THE ABOVE LISTED TRADES OR THOSE REQUIRED TO BE IDENTIFIED IN THE SPECIFICATIONS ARE TO BE USED TO PERFORM THE WORK

In compliance with N.J.S.A. 40A:11-16 and the bid specifications, the undersigned hereby lists the name or names of the following subcontractors:

Company Name: _____

Address: _____

Telephone: _____ Subcontract Amount: \$ _____

Specific Scope of Work Subcontracted: _____

License No. _____

Company Name: _____

Address: _____

Telephone: _____ Subcontract Amount: \$ _____

Specific Scope of Work Subcontracted: _____

License No. _____

Company Name: _____

Address: _____

Telephone: _____ Subcontract Amount: \$ _____

Specific Scope of Work Subcontracted: _____

License No. _____

IF MORE THAN THREE SUBCONTRACTORS, PLEASE COPY THIS SHEET AS NECESSARY AND ATTACH TO THE BID PACKAGE.

(Continued on following page)

Bidder's Name _____

SUBCONTRACTOR IDENTIFICATION CERTIFICATION

Note the law does not permit the listing of alternate subcontractors. However, multiple subcontractors for the same trade are permitted to be named provided the bidder meets the following requirements:

- Bidder identifies each subcontractor named for that category;
- Bidder states the scope of work, goods and services (the portion of the work) to be performed by each subcontractor; and
- Bidder provides the price quote provided by each subcontractor.

The bidder is advised that any change of subcontractor(s) from ones listed herein is subject to the County's approval. Change of subcontractor(s) will be approved only if made for good cause and not as a result of an arbitrary purpose.

The undersigned Bidder certifies and declares that the subcontractors listed above shall be used as subcontractors to complete certain portions of the work in this project as set forth in N.J.S.A. 40A: 11-16.

Witness

Date _____

NAME OF BIDDER

ADDRESS

By: _____
ORIGINAL SIGNATURE ONLY

PRINT NAME AND TITLE

Bidder's Name _____

ACKNOWLEDGMENT OF ADDENDUM

COUNTY OF UNION

(Name of Construction /Public Works Project)

(Project or Bid Number)

Pursuant to N.J.S.A. 40A:11-23.1a., the undersigned bidder, hereby acknowledges receipt of the following notices, revisions, or addenda to the bid advertisement, specifications or bid documents. By indicating date of receipt, bidder acknowledges the submitted bid takes into account the provisions of the notice, revision or addendum. Note that the County of Union's record of notice to bidders shall take precedence and that failure to include provisions of changes in a bid proposal may be subject for rejection of the bid.

Local Unit Reference Number or Title of Addendum/Revision	How Received (mail, fax, pick- up, etc.)	Date Received

ACKNOWLEDGMENT BY BIDDER:

NAME OF BIDDER: _____

ORIGINAL SIGNATURE: _____

PRINTED NAME AND TITLE: _____

DATE: _____

CONTRACTOR BUSINESS REGISTRATION CERTIFICATE

New Mandatory Requirement - Effective 1/18/2010

The recently enacted **P.L. 2009, c.315**, requires that effective January 18, 2010; a contracting agency must receive proof of the bidder's business registration prior to the award of a contract. However, the proof must show that the bidder was in fact registered with the State of New Jersey Department of the Treasury, Division of Revenue and obtained the business registration prior to the receipt of bids.

If subcontractors are named on the bid, proof of the business registration for each subcontractor must be provided prior to the award of bid. Similarly to the bidder, the proof must show that each subcontractor was registered with the State of New Jersey Department of the Treasury, Division of Revenue and obtained the business registration prior to the receipt of bids.

Proof of business registration shall be

- A copy of a Business Registration Certificate issued by the Department of the Treasury, Division of Revenue; or
- A copy of the web version provided by the NJ Division of Revenue, or

Register online at www.nj.gov/treasury/revenue/taxreg.htm. Click the "online" link and then select "Register for Tax and Employer Purposes or call the Division at 609-292-1730.

Note: A NJ Certificate of Authority is not acceptable.

FAILURE to submit proof of registration of the bidder or any subcontractor named on the bid prior to the award of a contract shall be cause to reject the bids.

FAILURE of the bidder or any subcontractor named on the bid to be registered prior to the receipt of bids is cause for a **MANDATORY REJECTION** of bids. (A NON-WAIVABLE DEFECT). This covers construction work as well as non-construction bids.

IN ADDITION:

The contractor shall provide written notice to all **subcontractors and suppliers** not specifically named on the bid of the responsibility to register and submit proof of business registration to the contractor. The requirement of proof of business registration extends down through all levels (tiers) of the project.

Before final payment on the contract is made by the contracting agency, the contractor shall submit an accurate list and the proof of business registration of each subcontractor or supplier used in the fulfillment of the contract, or shall attest that no subcontractors were used.

For the term of the contract, the contractor and each of its affiliates and a subcontractor and each of its affiliates [N.J.S.A. 52:32-44(g)(3)] shall collect and remit to the Director, New Jersey Division of Taxation, the use tax due pursuant to the Sales and Use Tax Act on all sales of tangible personal property delivered into this State, regardless of whether the tangible personal property is intended for a contract with a contracting agency.

A business organization that fails to provide a copy of a business registration as required pursuant to section 1 of P.L.2001,c.134 (C.52:32-44 et al.) or subsection e. or f. of section 92 of P.L.1977,c.110 (C.5:12-92), or that provides false business registration information under the requirements of either of those sections, shall be liable for a penalty of \$25 for each day of violation, not to exceed \$50,000 for each business registration copy not properly provided under a contract with a contracting agency.

BUSINESS REGISTRATION
Mandatory Requirement

P.L. 2009, c.315, requires that effective January 18, 2010; a contracting agency must receive proof of the bidder's business registration prior to the award of a contract. However, the proof must show that the bidder was in fact registered with the State of New Jersey Department of the Treasury, Division of Revenue and obtained the business registration prior to the receipt of bids.

If subcontractors are named on the bid, proof of the business registration for each must be provided prior to the award of a contract. Similarly to the bidder, the proof must show that each subcontractor was registered with the State of New Jersey Department of the Treasury, Division of Revenue and obtained the business registration prior to the receipt of bids.

Proof of business registration shall be:

- A copy of a Business Registration Certificate issued by the Department of Treasury, Division of Revenue; or
- A copy of the web printed version provided by the NJ Division of Revenue

STATE OF NEW JERSEY BUSINESS REGISTRATION CERTIFICATE FOR STATE AGENCY AND CASINO SERVICE CONTRACTORS	
TAXPAYER NAME:	TRACE NAME:
TAX REGISTRATION TEST ACCOUNT	CLIENT REGISTRATION
TAXPAYER IDENTIFICATION:	SEQUENCE NUMBER:
090-007-082/000	01072300
ADDRESS:	ISSUANCE DATE:
847 ROEBLING AVE TRENTON NJ 08611	07/14/04
EFFECTIVE DATE:	
01/01/01	
FORM BR(C)06(01)	<small>This Certificate is NOT assignable or transferable. It must be temporarily displayed at above address.</small>

STATE OF NEW JERSEY BUSINESS REGISTRATION CERTIFICATE	
Taxpayer Name:	TAX REG TEST ACCOUNT
Trade Name:	
Address:	847 ROEBLING AVE TRENTON, NJ 08611
Certificate Number:	1093907
Date of Issuance:	October 14, 2004
For Office Use Only:	20041014112823533

ATTACH BRC HERE

Bidder's Name _____

AFFIRMATIVE ACTION REQUIREMENT

REQUIRED AFFIRMATIVE ACTION EVIDENCE

General Requirements of P.L. 1975, c. 127: You are hereby put on notice that:

CONSTRUCTION CONTRACTS: The successful contractor must submit within three (3) days of the notice of intent to award or the signing of the contract the initial project manning report (A.A.201). This report should be submitted at the time the signed contract is returned to the County of Union. Attention: *Affirmative Action Officer*.

If the successful contract does not submit the initial project manning report (A.A.201) within the three (3) days from the time the signed contract is returned to the County of Union, the County of Union WILL declare the contractor non-responsive and award the contract to the next lowest responsible bidder.

NAME OF BIDDER

ORIGINAL SIGNATURE

PRINT OR TYPE NAME AND TITLE

DATE THIS FORM IS COMPLETED

Bidder's Name _____

EXPERIENCE STATEMENT

I hereby certify that my company has performed the following private or public work, which is relevant to this bid. I further certify that my company has never defaulted under any contract. Should you not sign this form due to prior defaults, please provide details on an attached sheet.

Witness

Date

NAME OF BIDDER

ADDRESS

By: _____
ORIGINAL SIGNATURE ONLY

PRINT NAME AND TITLE

YOU MAY ATTACH ADDITIONAL SHEETS, BUT YOU MUST SIGN AND WITNESS THIS SHEET.

Bidder's Name _____

NON-COLLUSION AFFIDAVIT

(N.J.S.A. 52:34-15)

STATE OF _____)
) SS: _____
COUNTY OF _____)

I _____, of the City of _____, in the County of _____, and the State of _____, of full age, being duly sworn according to law, on my oath depose and say that: I am _____ of the firm of _____, the bidder making the proposal for the above named project, and that I executed the said proposal for the above named project, and that I executed the said proposal with full authority to do so; that said bidder has not, directly or indirectly, entered into any agreement, participation in any collusion, or otherwise taken any action in restraint of free, competitive bidding in connection with the above named project; and that all statements contained in said proposal and in this Affidavit are true and correct, and made with full knowledge that the COUNTY OF UNION, NEW JERSEY relies upon the truth of the statements contained in said proposal and in the statements contained in the affidavit in awarding the contract for the said project.

I further warrant that no person or selling agency has been employed or retained to solicit or secure such contract upon an agreement or understanding for a commission, percentage, brokerage or contingent fee, except bona fide employees or bonafide established commercial or selling agencies maintained by _____ (N.J.S.A. 52:34-15).

NAME OF BIDDER

ORIGINAL SIGNATURE ONLY

NOTE: The person who signed the bidder signature page for the bidder should sign this form also.

Subscribed and sworn before me
this ____ day of _____, 20____.

Notary Public of the State of _____
My commission expires: _____

WARNING: IF YOU FAIL TO FULLY, ACCURATELY, AND COMPLETELY FILL OUT THIS AFFIDAVIT OF NON-COLLUSION, YOUR BID MAY BE REJECTED.

Bidder's Name _____

Contractor Registration Advisement
For Public Works Projects

A new law, known as "The Public Works Contractor Registration Act" (P.L. 1999, c.238), became effective April 11, 2000. Under the Act, no contractor/subcontractor will be permitted to bid on or engage in any contract for public work, as defined in Section 2 of P.L. 1963, c.150 (C:34:11-56.26), unless that contractor/subcontractor is registered with the New Jersey Department of Labor and Workforce Development. The Act provides that upon registration with the Department, a public works contractor/subcontractor will be issued a certificate by the Department indicating compliance with the Act's requirements. The registration fee has been set at \$300.00 per year. Upon the effective date of the Act, public bodies will be expected to request production of such a certificate from those bidding on or engaging in public works projects.

It is important to note that the term "contractor," is defined in the, Act as, "a person, partnership, association, joint stock company, trust, corporation or other legal business entity or successor thereof who enters into a contract which is subject to the provision of the "New Jersey Prevailing Wage Act," P.L. 1963, c.150 (C.34:11-56.25, et seq.) for the construction, reconstruction, demolition, alteration, repair or maintenance of a public building regularly open to and used by the general public or a public institution, and includes any subcontractor or lower tier subcontractor as defined herein: except that, for the purposes of the act, no pumping station, treatment plant or other facility associated with utility and environmental construction, reconstruction, demolition, alteration, repair or maintenance shall be regarded as a public building regularly open to and used by the general public or a public institution."

Registration forms, copies of the Act, and other relevant information can be obtained by contacting:

Contractor Registration Unit
New Jersey Department of Labor and Workforce Development
Division of Wage & Hour Compliance
PO Box 389
Trenton, New Jersey 08625-0389
Telephone: 609-292-9464
Fax: 609-633-8591
E-mail: contreg@dol.state.nj.us

AMERICANS WITH DISABILITIES ACT
EQUAL OPPORTUNITY FOR INDIVIDUALS WITH DISABILITIES

The contractor and the County of Union (hereafter "Owner") do hereby agree that the provisions of Title II of the Americans With Disabilities Act of 1990 (the "Act") (42 U.S.C. S12101 et seq.), which prohibits discrimination on the basis of disability by public entities in all services, programs and activities provided or made available by public entities, and the rules and regulations promulgated pursuant thereto, are made a part of this contract. In providing any aid, benefit, or service on behalf of the Owner pursuant to this contract, the contractor agrees that the performance shall be in strict compliance with the Act. In the event the contractor, its agents, servants, employees, or subcontractors violate or are alleged to have violated the Act during the performance of this contract, the contractor shall defend the Owner in any action or administrative proceeding commenced pursuant to this Act. The contractor shall indemnify, protect, and save harmless the Owner, its agents, servants, and employees from and against any and all suits, claims, losses, demands, or damages of whatever kind or nature arising out of or claimed to arise out of the alleged violation. The contractor shall, at its own expense, appear, defend, and pay any and all charges for legal services and any and all costs and other expenses arising from such action or administrative proceeding or incurred in connection therewith. In any and all complaints brought pursuant to the Owner's grievance procedure, the contractor agrees to abide by any decision of the Owner which is rendered pursuant to said grievance procedure. If any action or administrative proceeding results in an award of damages against the Owner, or if the Owner incurs any expense to cure a violation of the ADA which has been brought pursuant to its grievance procedure, the contractor shall satisfy and discharge the same at its own expense.

The Owner shall, as soon as practicable after a claim has been made against it, give written notice thereof to the contractor along with full and complete particulars of the claim. If any action or administrative proceeding is brought against the Owner or any of its agents, servants, and employees, the Owner shall expeditiously forward or have forwarded to the contractor every demand, complaint, notice, summons, pleading, or process received by the Owner or its representatives.

It is expressly agreed and understood that any approval by the Owner of the services provided by the contractor pursuant to this contract will not relieve the contractor of the obligation to comply with the Act and to defend, indemnify, protect, and save harmless the Owner pursuant to this paragraph.

It is further agreed and understood that the Owner assumes no obligation to indemnify or save harmless the contractor, its agents, servants, employees and subcontractors for any claim which may arise out of their performance of this Agreement. Furthermore, the contractor expressly understands and agrees that the provisions of this indemnification clause shall in no way limit the contractor's obligations assumed in this Agreement, nor shall they be construed to relieve the contractor from any liability, nor preclude the Owner from taking any other actions available to it under any other provisions of this Agreement or otherwise at law.

Name _____ (Please print or type)

Signature _____ Date _____

STATEMENT OF BIDDER'S QUALIFICATIONS

All questions must be answered and the data given must be clear and comprehensive. This statement must be notarized. Questions may be answered on separate attached sheets. The Bidder may submit any additional information it desires.

1. _____
(Name of Bidder)

2. _____
(Permanent Main Office Address)

3. _____
(When Organized)

4. _____
(If a Corporation, where incorporated)

5. Number of years your organization has been engaged in construction or contracting business under present firm or trade name? _____

6. How many years of experience in construction work has your organization had (a) as a general contractor? And/or (b) As a subcontractor? _____

7. Contracts on hand: (Attach a list or table showing gross amounts of each Contract and the appropriate dates of completion) _____

8. General character of work performed by you. _____

9. Have you ever failed to complete any work awarded to you? _____

10. Have you ever defaulted on a Contract? _____ If so, complete details, including where and why?

STATEMENT OF BIDDER'S QUALIFICATIONS - (continued)

11. Has any officer or partner of your organization ever failed to complete a construction contract handled in its own name? If so, state name of individual, name of owner, location and type of project, and reason for the failure to complete. _____

12. List your major equipment available for this Contract.

13. Experience in the construction work similar in importance to this Project.

14. Have you had any material adverse changes from the trades as listed in NJ Notice of Classification within last five (5) years? _____. If so, list prior classification.

15. Background and experience of the principal members of your organization, including the officers.

Individual's Name	Present Position or Office	Yrs. of Construction Experience	Magnitude & Type of Work	In What Capacity

Bidder's Name _____

16. Bank Reference. (Name, Address, Phone, Representative) _____
17. Will you, upon request, fill out a detailed financial statement? _____
18. The undersigned, hereby authorizes and requests any person, firm or corporation to furnish any information requested by the proper agency in verification of the responses comprising this Statement of Bidder's Qualifications.
19. Bidder's telephone number, fax number and e-mail address (if applicable).
- Phone _____
- Fax _____
- E-mail _____
- Mobile _____

Dated at _____ this _____ day of _____, 20__.

BIDDER (Signature)

BIDDER (Print Name)

Subscribed and sworn to before me
this _____ day of _____, 20__.

(Seal) Notary Public of New Jersey/
Specify Other State
My Commission Expires _____, 20__.

**NOTE: FAILURE TO COMPLETE AND SUBMIT THIS DOCUMENT WITH
YOUR PROPOSAL MAY RESULT IN A REJECTION OF YOUR BID.**

Bidder's Name _____

CONTRACTOR PERFORMANCE RECORD

List all contracts completed by you below or provide separate form.

Name of Owner	Name & Location of Project: Type Of Work	Prime or Sub-Cont.	Engineer or Architect in Charge for Owner	Contract Price (Omit Cost)	Date Completed	Was Time* Extension Necessary	Were Any Penalties Imposed	Were Liens* Claims or Stop Notice Filed

* If answer is YES, provide explanation of details in connection with non-completion of contracts, time extensions, penalties imposed, labor troubles, liens, claims and notices filed against contracts listed in preceding item "Performance Record" on an attached sheet.

NOTE: FAILURE TO COMPLETE AND SUBMIT THIS DOCUMENT WITH YOUR PROPOSAL MAY RESULT IN A REJECTION OF YOUR BID.

Bidder's Name _____

CONTRACTOR PERFORMANCE RECORD
CERTIFICATION

The information above is true and complete to the best of my knowledge and belief.

(Name of Organization)

(Signature)

(Title)

Subscribed and sworn to before me

this _____ day of _____, 20__.

(Seal) Notary Public of New Jersey/
Specify Other State

My Commission Expires _____, 20__.

PRIOR NEGATIVE EXPERIENCE QUESTIONNAIRE

(N.J.S.A. 40A:11-4)

1. Within the past ten (10) years, have you been found, through either court adjudication, arbitration, mediation, or other contractually stipulated alternate dispute resolution mechanism, to have: failed to provide or perform goods or services; or failed to complete a contract in a timely manner; or otherwise performed unsatisfactorily under a prior contract with a public entity?

_____ yes _____ no If yes, please provide full, detailed explanation.

2. Within the past ten (10) years, have you defaulted on a contract, thereby requiring a public entity to utilize the services of another contractor to provide the goods or perform the services or to correct or complete the contract?

_____ yes _____ no If yes, please provide full, detailed explanation.

3. Within the past ten (10) years, have you defaulted on a contract, thereby requiring a public entity to look to your surety for completion of the contract or tender of the costs of completion?

_____ yes _____ no If yes, please provide full, detailed explanation.

4. Within the past ten (10) years, have you been debarred or suspended from contracting with any of the agencies or department of the executive branch of the State of New Jersey at the time of the contract award, where the action was based on failure to perform a contact for goods or services with a public entity?

_____ yes _____ no If yes, please provide full, detailed explanation.

Bidder's Name _____

PRIOR NEGATIVE EXPERIENCE CERTIFICATION

I hereby certify that the above statements are true and accurate as of this _____
day of _____, 20__.

Name of Contractor

By _____
(Signature of Authorized Representative)

Subscribed and sworn to before me

this _____ day of _____, 20__.

(Seal) Notary Public of New Jersey/
Specify Other State

My Commission Expires _____, 20__.

NOTE: FAILURE TO COMPLETE AND SUBMIT THIS DOCUMENT WITH YOUR PROPOSAL MAY RESULT IN A REJECTION OF YOUR BID.

TO BE COMPLETED ONLY WHEN FINAL PAYMENT IS REQUESTED

CONTRACTOR'S CERTIFICATION OF COMPLIANCE - NEW JERSEY PREVAILING WAGE ACT

TO: County of Union
Division of Engineering
2325 South Avenue
Scotch Plains, New Jersey 07076

CONTRACT:

PROJECT:

In accordance with the requirements of the New Jersey Prevailing Wage Act, N.J.S.A. 34:11-56 et al *, the undersigned contractor on the public work being performed for:

COUNTY OF UNION

hereby certifies that he/she has complied with the contract requirements regarding the payment of the minimum prevailing wages established under "The New Jersey Prevailing Wage Act" N.J.S.A. 34:11-56 et al.

CONTRACTOR: _____
ADDRESS: _____

BY: _____

ORIGINAL SIGNATURE ONLY

STATE OF NEW JERSEY
COUNTY OF _____

Being by me duly sworn according to law, on his oath deposes and says that _____ is _____ of _____ the above named contractor, and that the facts set forth in the above statement are true.

Subscribed and sworn before me
this ____ day of _____, 200__.

Notary Public: _____
My Commission Expires: _____

* N.J.S.A. 34:11-56.33 requires the contractor and subcontractor to file written statements with the public body in form satisfactory to the Commissioner certifying to the amounts then due and owing from such contractor and subcontractor filing such statement to any and all workmen for wages due on account of the public work, setting forth therein the names of the persons whose wages are unpaid and the amount due to each respectively. Union County will withhold the amount so deducted for the benefit of the workmen whose wages are unpaid as shown by the verified statement filed, and will pay directly to any workman the amount shown by such statement to be due to him for such wages. Such payment shall thereby discharge the obligation of the contractor to the person receiving such payment to the extent of the amount thereof.

Bidder's Name _____

UNCOMPLETED CONTRACTS AFFIDAVIT
(To be Submitted with DPMC Form 701)

PURSUANT TO N.J.A.C. 17:19-2.13, BIDDER DECLARES THE FOLLOWING WITH RESPECT TO ITS UNCOMPLETED CONTRACTS, ON ALL WORK, FROM WHATEVER SOURCE (PUBLIC AND PRIVATE), BOTH IN NEW JERSEY AND FROM OTHER GOVERNMENTAL JURISDICTIONS

ENTITY	PROJECT TITLE	ORIGINAL CONTRACT AMOUNT	UNCOMPLETED AMOUNT AS OF BID OPENING DATE	NAME AND TELEPHONE NUMBER OF PARTY TO BE CONTACTED FROM ENTITY FOR VERIFICATION

TOTAL AMOUNT OF UNCOMPLETED CONTRACTS \$ _____

Sworn and Subscribed to Before me

This _____ day of _____, 20____

Notary Public

BIDDER:

(Signature)

(Print Name)

NOTE: FAILURE TO COMPLETE AND SUBMIT THIS DOCUMENT WITH YOUR PROPOSAL MAY RESULT IN A REJECTION OF YOUR BID.

Bidder's Name _____

CERTIFICATE OF INSURANCE STATEMENT

The Bidder fully understands the County of Union insurance requirements as stated in the Instructions to Bidders as well as the Owner/Contractor Agreement and agrees to provide all insurance required by these documents prior to the issuance of the Notice to Proceed.

BIDDER (Signature)

BIDDER (Print Name)

NOTE: FAILURE TO COMPLETE AND SUBMIT THIS DOCUMENT WITH YOUR PROPOSAL MAY RESULT IN A REJECTION OF YOUR BID.

Bidder's Name _____

COLLECTION OF USE TAX ON SALES TO LOCAL GOVERNMENTS STATEMENT

The Bidder fully understands the requirements of the use tax on sales to local governments as stated in the General Conditions to the Contract for Construction and the Instructions to Bidders, and agrees at all times to comply with the "Contractor Use Tax Collection Legislation", as defined therein, and the terms relating thereto contained in the Contract Documents.

BIDDER (Signature)

BIDDER (Print Name)

NOTE: FAILURE TO COMPLETE AND SUBMIT THIS DOCUMENT WITH YOUR PROPOSAL MAY RESULT IN A REJECTION OF YOUR BID.

Bidder's Name _____

TIME OF COMPLETION

The undersigned proposed that if awarded the Contract, the scope of work will be started within ten (10) calendar days of the date of the Notice to Proceed and will be substantially completed no later than March 31, 2020.

The contractor will be required to comply with the following timing restrictions. The contractor shall cease all construction activity on June 1, 2019. Construction activities will resume on or about August 15, 2019 as directed by the County Engineer.

I, _____ of _____
NAME (Print or type) COMPANY

Agree to complete work in the time frame specified _____
SIGNATURE

SITE VISIT – GENERAL CONTRACTOR

I, _____ of _____
NAME (Print or type) COMPANY

Visited the site of the work on _____
SIGNATURE

Bidder's Name _____

**COUNTY OF UNION NEW JERSEY
Division of Purchasing
DISCLOSURE OF INVESTMENT ACTIVITIES IN IRAN FORM**

Solicitation Number: _____

Vendor/Bidder: _____

PART 1

CERTIFICATION

**VENDOR/BIDDER MUST COMPLETE PART 1 BY CHECKING ONE OF THE BOXES
FAILURE TO CHECK ONE OF THE BOXES WILL RENDER THE PROPOSAL NON-RESPONSIVE**

Pursuant to Public Law 2012, c. 25, any person or entity that submits a bid or proposal or otherwise proposes to enter into or renew a contract must complete the certification below to attest, under penalty of perjury, that neither the person nor entity, nor any of its parents, subsidiaries, or affiliates, is identified on the State of New Jersey, Department of the Treasury's Chapter 25 list as a person or entity engaged in investment activities in Iran. The Chapter 25 list is found on the Department's website at <http://www.state.nj.us/treasury/pdf/Chapter25List.pdf>. Vendors/Bidders **must** review this list prior to completing the below certification. **Failure to complete the certification will render a Vendor's/Bidder's proposal non-responsive.** If the Director of the Division of Purchase and Property finds a person or entity to be in violation of the law, s/he shall take action as may be appropriate and provided by law, rule or contract, including but not limited to, imposing sanctions, seeking compliance, recovering damages, declaring the party in default and seeking debarment or suspension of the party.

CHECK THE APPROPRIATE BOX

A. I certify, pursuant to Public Law 2012, c.25, that neither the Vendor/Bidder listed above nor any of its parents, subsidiaries, or affiliates is listed on the N.J. Department of Treasury's list of entities determined to be engaged in prohibited activities in Iran pursuant to P.L. 2012, c. 25 ("Chapter 25 List"). Disregard Part 2 and complete and sign the Certification below.

OR

B. I am unable to certify as above because the Vendor/Bidder and/or one or more of its parents, subsidiaries, or affiliates is listed on the Department's Chapter 25 list. I will provide a detailed, accurate and precise description of the activities in Part 2 below and sign and complete the Certification below. Failure to provide such information will result in the proposal being rendered as non-responsive and appropriate penalties, fines and/or sanctions will be assessed as provided by law.

PART 2

PLEASE PROVIDE ADDITIONAL INFORMATION RELATED TO INVESTMENT ACTIVITIES IN IRAN

If you checked Box "B" above, provide a detailed, accurate and precise description of the activities of the Vendor/Bidder, or one of its parents, subsidiaries or affiliates, engaged in investment activities in Iran by completing the information below.

ENTITY NAME: _____
RELATIONSHIP TO VENDOR/BIDDER: _____
DESCRIPTION OF ACTIVITIES: _____
DURATION OF ENGAGEMENT: _____
ANTICIPATED CESSATION DATE: _____
VENDOR/BIDDER CONTACT NAME: _____
VENDOR/BIDDER CONTACT PHONE#: _____

Attach Additional Sheets If Necessary

CERTIFICATION

I, the undersigned, certify that I am authorized to execute this certification on behalf of the Vendor/Bidder, that the foregoing information and any attachments hereto, to the best of my knowledge are true and complete. I acknowledge that the County of Union, New Jersey is relying on the information contained herein, and that the Vendor/Bidder is under a continuing obligation from the date of this certification through the completion of any contract(s) with the County of Union to notify the County of Union in writing of any changes to the information contained herein; that I am aware that it is a criminal offense to make a false statement or misrepresentation in this certification. If I do so, I will be subject to criminal prosecution under the law, and it will constitute a material breach of my agreement(s) with the County of Union, permitting the County of Union to declare any contract(s) resulting from this certification void and unenforceable.

Signature _____

Date _____

Print Name and Title _____

Revised 10/19/17



STATE OF NEW JERSEY
Department of Labor and Workforce Development
Division of Wage and Hour Compliance - Public Contracts Section
PO Box 389
Trenton, NJ 08625-0389

PREVAILING WAGE RATE DETERMINATION

The New Jersey Prevailing Wage Act (N.J.S.A. 34:11-56.25 et seq.) requires that the Department of Labor and Workforce Development establish and enforce a prevailing wage level for workers engaged in public works in order to safeguard their efficiency and general well being and to protect them as well as their employers from the effects of serious and unfair competition.

Prevailing wage rates are wage and fringe benefit rates based on the collective bargaining agreements established for a particular craft or trade in the locality in which the public work is performed. In New Jersey, these rates vary by county and by the type of work performed.

Applicable prevailing wage rates are those wages and fringe benefits in effect on the date the contract is awarded. All pre-determined rate increases listed at the time the contract is awarded must also be paid, beginning on the dates specified. Rates that have expired will remain in effect until new rates are posted.

Prevailing Wage Rate

The prevailing wage rate for each craft will list the effective date of the rate and the following information:

W = Wage Rate per Hour **B** = Fringe Benefit Rate per Hour* **T** = Total Rate per Hour

* Fringe benefits are an integral part of the prevailing wage rate. Employers not providing such benefits must pay the fringe benefit amount directly to the employee each payday. Employers providing benefits worth less than the fringe benefit amount must pay the balance directly to the employee each payday.

Unless otherwise stated in the Prevailing Wage Rate Determination, the fringe benefit rate for overtime hours remains at the straight time rate.

When the Overtime Notes in the Prevailing Wage Rate Determination state that the overtime rates are "inclusive of benefits," the benefit rate is increased by the same factor as the wage rate (i.e. multiplied by 1.5 for time and one-half, multiplied by 2 for double time, etc.).

Apprentice Rate Schedule

An "apprentice" is an individual who is registered with the United States Department of Labor - Office of Apprenticeship and enrolled in a certified apprenticeship program during the period in which they are working on the public works project.

The apprentice wage rate is a percentage of the journeyman wage rate, unless otherwise indicated. The apprentice benefit rate is the full journeyman benefit rate, unless otherwise indicated.

If there is no apprentice rate schedule listed, the individual must be paid at least the journeyman rate even if that individual is in a certified apprentice program for that trade.

If there is no ratio of apprentices to journeymen listed for a particular craft, then the ratio shall be one (1) apprentice to every four (4) journeymen.

Comments/Notes

For each craft listed there will be comments/notes that cover the definition of the regular workday, shift differentials, overtime, recognized holidays, and any other relevant information.

Public Works Contractor Registration

The Public Works Contractor Registration Act (N.J.S.A. 34:11-56.48, et seq.) requires that **all** contractors, subcontractors, or lower tier subcontractors who are working on or who bid on public works projects register with the Department of Labor and Workforce Development. Applications are available at www.nj.gov/labor (click on Wage & Hour and then go to Registration & Permits).

Pursuant to N.J.S.A. 34:11-56.51:

No contractor shall bid on any contract for public work as defined in section 2 of P.L.1963, c. 150 (C.34:11-56.26) unless the contractor is registered pursuant to this act. No contractor shall list a subcontractor in a bid proposal for the contract unless the subcontractor is registered pursuant to P.L.1999, c.238 (C.34:11-56.48 et seq.) at the time the bid is made. No contractor or subcontractor, including a subcontractor not listed in the bid proposal, shall engage in the performance of any public work subject to the contract, unless the contractor or subcontractor is registered pursuant to that act.

Snow Plowing

Snow plowing contracts are not subject to the New Jersey Prevailing Wage Act or the Public Works Contractor Registration Act.

**NEW JERSEY DEPARTMENT OF LABOR AND WORKFORCE DEVELOPMENT
PREVAILING WAGE RATE DETERMINATION**

County - UNION

Craft: Air Conditioning & Refrigeration - Service and Repair

PREVAILING WAGE RATE

	03/01/18
Journeyman (Mechanic)	W37.98 B23.93 T61.91

Craft: Air Conditioning & Refrigeration - Service and Repair

APPRENTICE RATE SCHEDULE

INTERVAL	PERIOD AND RATES									
	Mo. 1-3	Mo. 4-12	2nd Year	3rd Year	4th Year	5th Year		Wage = %	of Jnymn	Wage
As Shown										
Wage and Bene	50%	55%	60%	65%	75%	85%		Bene = %	of Jnymn	Bene

Ratio of Apprentices to Journeymen - 1:4

APPRENTICE RATE SCHEDULE FOR THOSE APPRENTICES ENTERING PROGRAM AFTER 3-1-13:

INTERVAL	PERIOD AND RATES							
As Shown	1st Year	2nd Year	3rd Year	4th Year	5th Year		Wage =% of Jnymn Wage	
Wage and Benefit	40%	50%	60%	70%	80%		Bene. =% of Jnymn Bene	

Craft: Air Conditioning & Refrigeration - Service and Repair

COMMENTS/NOTES

THESE RATES MAY BE USED FOR THE FOLLOWING:

- Service/Repair/Maintenance Work to EXISTING facilities.
- Replacement or Installation of air conditioning and refrigeration equipment when the combined tonnage does not exceed 15 tons for refrigeration, or 25 tons for air conditioning.
- Replacement or Installation of "packaged" or "unitary" rooftop-type units when the combined tonnage of the units does not exceed 75 tons.

NOTE: These rates may NOT be used for any work in new construction (including work on new additions).

The regular workday shall consist of 8 hours, starting between 6:00 AM and 10:00 AM, Monday through Friday.

SHIFT DIFFERENTIALS:

- The second and third shifts shall be paid an additional 15% of the hourly rate.
- All shifts must run for a minimum of 5 consecutive days.

OVERTIME:

Hours worked in excess of 8 per day or before or after the regular workday, that are not shift work, and all hours on Saturday shall be paid at time and one-half the hourly rate, inclusive of benefits. All hours on Sunday and holidays shall be paid at double the hourly rate, inclusive of benefits.

RECOGNIZED HOLIDAYS: New Year's Day, Presidents' Day, Memorial Day, July 4th, Labor Day, Veterans' Day, Thanksgiving Day, Christmas Day.

**NEW JERSEY DEPARTMENT OF LABOR AND WORKFORCE DEVELOPMENT
PREVAILING WAGE RATE DETERMINATION**

County - UNION

Craft: Boilermaker PREVAILING WAGE RATE

	01/01/19
Foreman	W49.72 B44.34 T94.06
General Foreman	W51.72 B45.34 T97.06
Journeyman	W44.72 B42.70 T87.42

Craft: Boilermaker APPRENTICE RATE SCHEDULE

INTERVAL	PERIOD AND RATES									
1000 Hours	65%	70%	75%	80%	85%	90%	95%			
Benefit =	36.36	37.26	38.18	39.07	39.39	40.89	41.79			

Ratio of Apprentices to Journeymen - *

* 1 apprentice will be allowed for the first 5 journeymen, 1 apprentice for the next 10 journeymen and 1 apprentice for each succeeding 20 journeymen up to a maximum of 5 apprentices per contractor on any one job.

Craft: Boilermaker COMMENTS/NOTES

HIGH WORK: All apprentices working on the erection, repair, or dismantling of smoke stacks, standpipes, or water towers shall be paid the Journeyman rate.

The regular workday shall consist of 8 hours, between 8:00 AM and 4:30 PM.

SHIFT DIFFERENTIALS:

- The second shift shall work 7½ hours and receive 8 hours pay, at a rate equal to the regular hourly rate plus 10%.
- The third shift shall work 7 hours and receive 8 hours pay, at a rate equal to the regular hourly rate plus 20%.
- For "Municipal Water Works" projects only, the following shall apply: Two, four day, 10 hour shifts may be worked at straight time Monday through Thursday. The day shift shall work four days, at 10 hours, for 10 hours pay. The second shift shall work four days, at nine and a half hours, for 10 hours pay, plus 10% the hourly rate for new work and .25 cents on repair work. Friday may be used as a make-up day at straight time, due to weather conditions, holiday or any other circumstances beyond the employer's control.

OVERTIME:

- Hours in excess of 8 per day, Monday through Friday, and all hours on Saturdays shall be paid at time and one-half the hourly rate. All hours on Sundays and holidays (except Labor Day) shall be paid at double the hourly rate. All hours on Labor Day shall be paid at four times the hourly rate.
- If any other craft employed by the same contractor, or a subcontractor thereof, receives double time in lieu of time and one-half, then the Boilermaker shall receive double time in lieu of time and one-half.
- For "Municipal Water Works" projects only, the following shall apply: Four 10 hour days may be worked Monday through Thursday at straight time. Friday may be used as a make-up day for a day lost to inclement weather, holiday or other conditions beyond the control of the employer. Overtime shall be paid for any hours that exceed 10 hours per day or 40 hours per week.

**NEW JERSEY DEPARTMENT OF LABOR AND WORKFORCE DEVELOPMENT
PREVAILING WAGE RATE DETERMINATION**

County - UNION

RECOGNIZED HOLIDAYS: New Year's Day, Washington's Birthday, Memorial Day, July 4th, Labor Day, Presidential Election Day, Veterans' Day, Thanksgiving Day, Christmas Day. Sunday holidays observed the following Monday.

**NEW JERSEY DEPARTMENT OF LABOR AND WORKFORCE DEVELOPMENT
PREVAILING WAGE RATE DETERMINATION**

County - UNION

Craft: Boilermaker - Minor Repairs

PREVAILING WAGE RATE

	01/01/19
Foreman	W32.80 B16.37 T49.17
General Foreman	W33.30 B16.37 T49.67
Mechanic	W31.30 B16.37 T47.67

Craft: Boilermaker - Minor Repairs

COMMENTS/NOTES

NOTE: These rates apply to MINOR REPAIR WORK ONLY (repair work in the field for which the contract amount does not exceed \$125,000.00).

OVERTIME:

Hours in excess of 8 per day, Monday through Friday, and all hours on Saturdays shall be paid at time and one-half the hourly rate. All hours on Sundays and holidays (except Labor Day) shall be paid at double the hourly rate. All hours on Labor Day shall be paid at four times the hourly rate.

RECOGNIZED HOLIDAYS: New Year's Day, Washington's Birthday, Good Friday, Memorial Day, July 4th, Labor Day, Presidential Election Day, Thanksgiving Day, day after Thanksgiving, Christmas Day. Saturday holidays observed the preceding Friday, Sunday holidays observed the following Monday.

**NEW JERSEY DEPARTMENT OF LABOR AND WORKFORCE DEVELOPMENT
PREVAILING WAGE RATE DETERMINATION**

County - UNION

Craft: Bricklayer, Stone Mason

PREVAILING WAGE RATE

	05/01/18
Deputy Foreman	W45.20 B33.03 T78.23
Foreman	W48.20 B33.03 T81.23
Journeyman	W42.20 B33.03 T75.23

Craft: Bricklayer, Stone Mason

APPRENTICE RATE SCHEDULE

INTERVAL	PERIOD AND RATES									
	40%	50%	55%	60%	65%	70%	75%	80%		
6 Months										
Benefits	3.86	4.83	5.31	5.80	21.83	23.27	24.72	26.15		

Ratio of Apprentices to Journeymen - 1:5

Craft: Bricklayer, Stone Mason

COMMENTS/NOTES

The regular workday shall consist of 8 hours, between 6:00 AM and 4:30 PM.

SHIFT DIFFERENTIALS:

- When a 2 shift schedule (including a day shift) is established, the first, or day shift, shall be established on an 8 hour basis. The second shift shall be established on an 8 hour basis, and receive the regular rate plus 10%, inclusive of benefits.
- When a three shift schedule is established, the first shift shall be established on an 8 hour basis, the second shift on a 7.5 hour basis, and the third shift on a 7 hour basis. The first shift shall receive the regular hourly rate, the second shift shall receive the regular rate plus 10%, inclusive of benefits, and the third shift shall receive the regular rate plus 15%, inclusive of benefits.
- When there is no day shift, and a second or third shift is established, it shall be established on an 8 hour basis. The second shift shall receive the regular rate plus 10%, inclusive of benefits, and the third shift shall receive the regular rate plus 15%, inclusive of benefits.
- When an irregular shift must be established, this shift shall receive the regular rate plus 10%, inclusive of benefits.

OVERTIME:

- The first 2 hours in excess of 8 per day, or before or after the regular workday that are not shift work, Monday through Friday, shall be paid at time and one-half the regular rate, inclusive of benefits. Any additional overtime shall be paid at double the regular rate, inclusive of benefits. The first 10 hours on Saturday shall be paid at time and one-half the regular rate, inclusive of benefits. Any additional overtime shall be paid at double the regular rate, inclusive of benefits. All hours on Sundays and holidays shall be paid at double the regular rate, inclusive of benefits.
- Saturday may be used as a make-up day for hours lost to inclement weather.
- When Bricklayers/Stone Masons work on Saturday with Laborers, and no other crafts are working on the project for the day, benefits may be paid at straight time. If other crafts are present, the applicable overtime rate for benefits shall be paid.

**NEW JERSEY DEPARTMENT OF LABOR AND WORKFORCE DEVELOPMENT
PREVAILING WAGE RATE DETERMINATION**

County - UNION

RECOGNIZED HOLIDAYS: New Year's Day, Presidents' Day, Memorial Day, July 4th, Labor Day, Presidential Election Day, Veterans' Day, Thanksgiving Day, Christmas Day. Sunday holidays will be observed the following Monday.

**NEW JERSEY DEPARTMENT OF LABOR AND WORKFORCE DEVELOPMENT
PREVAILING WAGE RATE DETERMINATION**

County - UNION

Craft: Carpenter PREVAILING WAGE RATE

	11/01/18
Foreman	W56.94 B32.45 T89.39
Journeyman	W49.51 B28.22 T77.73

Craft: Carpenter APPRENTICE RATE SCHEDULE

INTERVAL	PERIOD AND RATES									
Yearly	40%	55%	65%	80%	90%					
Benefit	57% of	Appren	tice	Wage	for all	intervals				

Ratio of Apprentices to Journeymen - 1:3

Craft: Carpenter COMMENTS/NOTES

FOREMAN REQUIREMENTS:

- When there are 2 or more Carpenters on a job, 1 shall be designated as a Foreman.
- When there are 21 or more Carpenters on a job, 2 shall be designated as Foremen.

The regular workday shall consist of 8 hours, starting between 7:00 AM and 9:00 AM.

SHIFT DIFFERENTIALS:

- When a 2 shift schedule (including a day shift) is established, the day shift shall be established on an 8 hour basis. The second shift shall be established on an 8 hour basis, and receive the regular rate plus 15%, inclusive of benefits.
- When a three shift schedule is established, the first shift shall be established on an 8 hour basis, the second shift on a 7.5 hour basis, and the third shift on a 7 hour basis. The first shift shall receive the regular hourly rate, the second shift shall receive the regular rate plus 15% and the third shift shall receive the regular rate plus 20%, inclusive of benefits.
- When there is no day shift, and a second or third shift is established, it shall be established on an 8 hour basis. The second shift shall receive the regular rate plus 15% and the third shift shall receive the regular rate plus 20%, inclusive of benefits.

OVERTIME:

- All hours in excess of 8 per day, or before or after an established shift that are not shift work, and all hours on Saturdays shall be paid at time and one-half the hourly rate, inclusive of benefits. All hours on Sundays and holidays shall be paid at double the hourly rate, inclusive of benefits.
- Four 10-hour days may be worked, Monday to Thursday, at straight time. Friday may be used as a make-up day for a day lost due to inclement weather. If Friday is not a make-up day, all hours on Friday shall be paid at time and one-half the hourly rate, inclusive of benefits.

RECOGNIZED HOLIDAYS: New Year's Day, Presidents' Day, Memorial Day, July 4th, Labor Day, Presidential Election Day, Veterans' Day, Thanksgiving Day, Christmas Day. Sunday holidays observed the following Monday.

**NEW JERSEY DEPARTMENT OF LABOR AND WORKFORCE DEVELOPMENT
PREVAILING WAGE RATE DETERMINATION**

County - UNION

Craft: Carpenter - Resilient Flooring

PREVAILING WAGE RATE

	11/01/18
Foreman	W56.94 B32.45 T89.39
Journeyman	W49.51 B28.22 T77.73

Craft: Carpenter - Resilient Flooring

APPRENTICE RATE SCHEDULE

INTERVAL	PERIOD AND RATES									
Yearly	40%	55%	65%	80%	90%					
Benefit	57%	of	Appren	tice	Wage	for all	intervals			

Ratio of Apprentices to Journeymen - *

* 1 apprentice shall be allowed to every 2 journeymen or major fraction thereof. No more than 3 apprentices on any one job or project.

Craft: Carpenter - Resilient Flooring

COMMENTS/NOTES

FOREMAN REQUIREMENTS:

- On any job where there are 4 or more Carpenters of Resilient Flooring, 1 must be designated a Foreman.

FOR SYNTHETIC TURF INSTALLATION ONLY:

- The rate shall be 90% of the wage and benefit rate.

The regular workday consists of 8 hours, starting between 6:00 AM and 9:00 AM.

SHIFT DIFFERENTIALS:

- When a 2 shift schedule (including a day shift) is established, the day shift, shall be established on an 8 hour basis. The second shift shall be established on an 8 hour basis, and receive the regular wage rate plus 15%.
- When a three shift schedule is established, the first shift shall be established on an 8 hour basis, the second shift on a 7.5 hour basis, and the third shift on a 7 hour basis. The first shift shall receive the regular wage rate, the second shift shall receive the regular wage rate plus 15% and the third shift shall receive the regular wage rate plus 20%.
- When there is no day shift, and a second or third shift is established, it shall be established on an 8 hour basis. The second shift shall receive the regular wage rate plus 15% and the third shift shall receive the regular wage rate plus 20%.

OVERTIME:

- Hours in excess of 8 per day or 40 per week, or before or after the regular workday, Monday through Friday, shall be paid at time and one-half the wage rate. Saturday may be used as a make-up day, at straight time, up to 8 hours, for hours lost to reasons beyond the control of the employer, up to a total of 40 hours per week; hours in excess of 8 on Saturday shall then be paid at time and one-half the wage rate. If Saturday is not a make-up day, all hours on Saturday shall be paid at time and one-half the wage rate. All hours on Sundays and holidays shall be paid at double the wage rate.
- Four 10-hour days may be worked, Monday to Thursday, at straight time. Friday may be used as a make-up day for hours lost to reasons beyond the control of the employer. If Friday is not a make-up day, all hours on Friday shall be paid at time and one-half the wage rate.

**NEW JERSEY DEPARTMENT OF LABOR AND WORKFORCE DEVELOPMENT
PREVAILING WAGE RATE DETERMINATION**

County - UNION

RECOGNIZED HOLIDAYS: New Year's Day, Presidents' Day, Memorial Day, July 4th, Labor Day, Presidential Election Day, Veterans' Day, Thanksgiving Day, Christmas Day. Sunday holidays will be observed the following Monday.

**NEW JERSEY DEPARTMENT OF LABOR AND WORKFORCE DEVELOPMENT
PREVAILING WAGE RATE DETERMINATION**

County - UNION

Craft: Cement Mason

PREVAILING WAGE RATE

See "Bricklayer, Stone Mason" Rates

Craft: Cement Mason

APPRENTICE RATE SCHEDULE

INTERVAL	PERIOD AND RATES									

Ratio of Apprentices to Journeymen - 1:4

Craft: Cement Mason

COMMENTS/NOTES

See "Bricklayer, Stone Mason" Rates

**NEW JERSEY DEPARTMENT OF LABOR AND WORKFORCE DEVELOPMENT
PREVAILING WAGE RATE DETERMINATION**

County - UNION

Craft: Dockbuilder PREVAILING WAGE RATE

	11/02/18
Foreman	W54.05 B46.87 T100.92
Foreman (Concrete Form Work)	W53.25 B33.76 T87.01
Journeyman	W47.00 B46.87 T93.87
Journeyman (Concrete Form Work)	W46.30 B33.76 T80.06

Craft: Dockbuilder APPRENTICE RATE SCHEDULE

<u>INTERVAL</u>	<u>PERIOD AND RATES</u>									
Yearly	18.80	23.50	30.55	37.60						
Benefit	31.25	for all	intervals							

Ratio of Apprentices to Journeymen - *

* When there are 4 or fewer Dockbuilders on a job, no more than 1 may be an apprentice. When there are 5 or more Dockbuilders, there may be 1 apprentice for every 5 Dockbuilders.

Craft: Dockbuilder COMMENTS/NOTES

APPRENTICE RATE SCHEDULE FOR CONCRETE FORM WORK ONLY:

INTERVAL	PERIOD AND RATES			
Yearly	18.52	23.15	30.10	37.04
Benefits	23.24 for all intervals			

CREOSOTE HANDLING:

When handling creosote products on land piledriving, floating marine construction, and construction of wharves, the worker shall receive an additional \$0.25 per hour.

HAZARDOUS WASTE WORK:

- Hazardous waste removal work on a state or federally designated hazardous waste site where Level A, B, or C personal protection is required: an additional 20% of the hourly rate, per hour.
- Hazardous waste removal work in Level D, or where personal protection is not required: an additional \$1.00 per hour.

CERTIFIED WELDER: When required on the job by the project owner, a Certified Welder shall receive an additional \$1.00 per hour.

FOREMAN REQUIREMENTS:

The first Dockbuilder on the job shall be designated a Foreman.

**NEW JERSEY DEPARTMENT OF LABOR AND WORKFORCE DEVELOPMENT
PREVAILING WAGE RATE DETERMINATION**

County - UNION

OVERTIME:

Hours in excess of 8 per day, Monday through Friday, and all hours on Saturdays shall be paid at time and one-half the hourly rate. All hours on Sundays and holidays shall be paid at double the hourly rate.

RECOGNIZED HOLIDAYS: New Year's Day, Presidents' Day, Memorial Day, July 4th, Labor Day, Veterans' Day, Presidential Election Day, Thanksgiving Day, Christmas Day. Veterans' Day may be switched with the day after Thanksgiving.

**NEW JERSEY DEPARTMENT OF LABOR AND WORKFORCE DEVELOPMENT
PREVAILING WAGE RATE DETERMINATION**

County - UNION

Craft: Drywall Finisher

PREVAILING WAGE RATE

	11/01/18
Foreman	W43.95 B24.40 T68.35
General Foreman	W45.94 B24.40 T70.34
Journeyman	W39.95 B24.40 T64.35

Craft: Drywall Finisher

APPRENTICE RATE SCHEDULE

INTERVAL	PERIOD AND RATES									
	40%	50%		60%	70%		80%	90%		
6 Months										
Benefits	Intervals	1 to 2 =	10.65	Intervals	3 to 4 =	13.17	Intervals	5 to 6 =	16.25	

Ratio of Apprentices to Journeymen - 1:4

Craft: Drywall Finisher

COMMENTS/NOTES

The regular workday shall consist of 8 hours between 7:00 AM and 5:30 PM.

SHIFT DIFFERENTIALS:

- The second shift shall receive an additional 10% of the hourly rate, per hour, and the third shift shall receive an additional 15% of the hourly rate, per hour.
- When 3 shifts are worked, the second shift shall receive 8 hours pay for 7.5 hours of work, and the third shift shall receive 8 hours pay for 7 hours of work.
- Shift work must run for a minimum of 5 consecutive workdays.

OVERTIME:

- Hours in excess of 8 per day, Monday through Friday, and all hours on Saturdays shall be paid at time and one-half the regular rate, inclusive of benefits. All hours on Sundays and holidays shall be paid at double the regular rate, inclusive of benefits.
- Saturday or Sunday may be used to make up a day lost to inclement weather, at straight time.

RECOGNIZED HOLIDAYS: New Year's Day, Memorial Day, July 4th, Labor Day, Presidential Election Day, Veterans' Day, Thanksgiving Day, Christmas Day. Saturday holiday observed the preceding Friday. Sunday holiday observed the following Monday.

**NEW JERSEY DEPARTMENT OF LABOR AND WORKFORCE DEVELOPMENT
PREVAILING WAGE RATE DETERMINATION**

County - UNION

Craft: Electrician

PREVAILING WAGE RATE

	06/07/18
Cable Splicer	W61.52 B35.38 T96.90
Foreman	W62.64 B36.03 T98.67
Journeyman	W55.93 B32.17 T88.10

Craft: Electrician

APPRENTICE RATE SCHEDULE

INTERVAL	PERIOD AND RATES									
	Yearly	40%	49%	58%	68%	80%		of Jour	neyman	Wage
Benefit	40%	49%	58%	68%	80%		of Jour	neyman	Benefit	Rate

Ratio of Apprentices to Journeymen - 2:3

Craft: Electrician

COMMENTS/NOTES

THESE RATES ALSO APPLY TO THE FOLLOWING:

- All burglar and fire alarm work.
- All fiber optic work.
- Teledata work in new construction.
- Teledata work involving 16 Voice/Data Lines or more.

The regular workday shall be 8 hours, between 8:00 AM and 4:30 PM.

FOREMAN REQUIREMENTS:

- On any job where there are 1 to 10 Journeymen electricians, 1 shall be designated a Foreman.

SHIFT DIFFERENTIALS:

- Shift work must run for a minimum of 5 consecutive workdays.
- 2nd Shift (4:30 PM to 12:30 AM) shall receive 8 hours pay for 7.5 hours work + an additional 10% of the regular rate, per hour, inclusive of benefits.
- 3rd Shift (12:30 AM to 8:00 AM) shall receive 8 hours pay for 7 hours work + an additional 15% of the regular rate, per hour, inclusive of benefits.

OVERTIME:

Hours in excess of 8 per day, or outside of the regular workday, Monday through Friday, and all hours on Saturdays, shall be paid at time and one-half the regular rate, inclusive of benefits. All hours on Sundays and holidays shall be paid at double the regular rate, inclusive of benefits.

**NEW JERSEY DEPARTMENT OF LABOR AND WORKFORCE DEVELOPMENT
PREVAILING WAGE RATE DETERMINATION**

County - UNION

RECOGNIZED HOLIDAYS: New Year's Day, Presidents' Day, Memorial Day, July 4th, Labor Day, Presidential Election Day, Veterans' Day, Thanksgiving Day, Christmas Day.

**NEW JERSEY DEPARTMENT OF LABOR AND WORKFORCE DEVELOPMENT
PREVAILING WAGE RATE DETERMINATION**

County - UNION

Craft: Electrician - Teledata (15 Voice/Data Lines & Less)

PREVAILING WAGE RATE

	10/29/18	10/28/19	11/02/20
Master	W54.86	W56.16	W57.42
Technician/General	B30.17	B30.89	B31.58
Foreman	T85.03	T87.05	T89.00
Senior Technician/Lead Foreman (21-30 Workers on Job)	W50.22 B27.62 T77.84	W51.41 B28.27 T79.68	W52.56 B28.91 T81.47
Technician A/Foreman (11-20 Workers on Job)	W48.11 B26.46 T74.57	W49.25 B27.08 T76.33	W50.35 B27.69 T78.04
Technician B/Working Foreman (4-10 Workers on Job)	W46.00 B25.30 T71.30	W47.09 B25.90 T72.99	W48.15 B26.47 T74.62
Technician C/Journeyman (1-3 Workers on Job)	W42.20 B23.21 T65.41	W43.20 B23.76 T66.96	W44.17 B24.29 T68.46

Craft: Electrician - Teledata (15 Voice/Data Lines & Less)

APPRENTICE RATE SCHEDULE

<u>INTERVAL</u>	<u>PERIOD AND RATES</u>										
6 Months						66%	72%	79%	86%		
Benefits						11.81	12.89	14.14	15.40		

Ratio of Apprentices to Journeymen - 2:3

Craft: Electrician - Teledata (15 Voice/Data Lines & Less)

COMMENTS/NOTES

APPRENTICE RATE SCHEDULE FOR THOSE APPRENTICES ENTERING PROGRAM AFTER 10-31-14:

INTERVAL	PERIOD AND RATES										
6 Months	35%	35%	40%	43%	48%	54%	61%	67%	74%	81%	
Benefits	6.76	6.76	7.16	7.70	8.59	9.66	10.82	11.99	13.25	14.51	

NOTES:

- These rates are for service, maintenance, moves, and/or changes affecting 15 Voice/Data (teledata) lines or less. These rates may NOT be used for any teledata work in new construction (including additions) or any fiber optic work.
- The number of Teledata workers on the jobsite is the determining factor for which Foreman category applies .

The regular workday shall be 8 hours, between 8:00 AM and 4:30 PM.

SHIFT DIFFERENTIALS:

- Shift work must run for a minimum of 5 consecutive workdays.

**NEW JERSEY DEPARTMENT OF LABOR AND WORKFORCE DEVELOPMENT
PREVAILING WAGE RATE DETERMINATION**

County - UNION

- 2nd Shift (4:30 PM to 12:30 AM) shall receive 8 hours pay for 7.5 hours work + an additional 10% of the regular rate, per hour, inclusive of benefits.
- 3rd Shift (12:30 AM to 8:00 AM) shall receive 8 hours pay for 7 hours work + an additional 15% of the regular rate, per hour, inclusive of benefits.

OVERTIME:

Hours in excess of 8 per day, or outside of the regular workday, Monday through Friday, and all hours on Saturdays, shall be paid at time and one-half the regular rate, inclusive of benefits. All hours on Sundays and holidays shall be paid at double the regular rate, inclusive of benefits.

RECOGNIZED HOLIDAYS: New Year's Day, Presidents' Day, Memorial Day, July 4th, Labor Day, Presidential Election Day, Veterans' Day, Thanksgiving Day, Christmas Day.

**NEW JERSEY DEPARTMENT OF LABOR AND WORKFORCE DEVELOPMENT
PREVAILING WAGE RATE DETERMINATION**

County - UNION

Craft: Electrician - Teledata (16 Instruments & More)

PREVAILING WAGE RATE

See "Electrician" Rates

Craft: Electrician - Teledata (16 Instruments & More)

COMMENTS/NOTES

See ELECTRICIAN Rates

**NEW JERSEY DEPARTMENT OF LABOR AND WORKFORCE DEVELOPMENT
PREVAILING WAGE RATE DETERMINATION**

County - UNION

Craft: Electrician- Outside Commercial

PREVAILING WAGE RATE

	06/07/18
Cable Splicer	W61.82 B35.09 T96.91
Certified Welder	W59.01 B33.50 T92.51
Equipment Operator	W56.20 B31.90 T88.10
Foreman (1-10 Journeyman workers on job)	W62.94 B35.73 T98.67
Foreman (11-20 Journeyman workers on job)	W64.62 B36.68 T101.30
General Foreman (21-30 Journeyman workers on job)	W66.32 B37.65 T103.97
General Foreman (31-60 Journeyman workers on job)	W71.94 B40.84 T112.78
General Foreman (61+ Journeyman workers on job)	W73.06 B41.47 T114.53
Groundman	W33.72 B19.15 T52.87
Journeyman Lineman/Technician	W56.20 B31.90 T88.10
Sub-Foreman	W62.94 B35.73 T98.67

**NEW JERSEY DEPARTMENT OF LABOR AND WORKFORCE DEVELOPMENT
PREVAILING WAGE RATE DETERMINATION**

County - UNION

Craft: Electrician- Outside Commercial

APPRENTICE RATE SCHEDULE

INTERVAL	PERIOD AND RATES									
1000 Hours	60%	65%	70%	75%	80%	85%	90%			
Benefits	56.75% of	Journey	man	wage	+	\$.01				

Craft: Electrician- Outside Commercial

COMMENTS/NOTES

EFFECTIVE 5-30-16- The apprentice benefit rate shall be 56.7% + \$.01.
 EFFECTIVE 5-29-17- The apprentice benefit rate shall be 56.7% + \$.01.
 EFFECTIVE 5-28-18- The apprentice benefit rate shall be 56.7% + \$.01.

* FOR UTILITY WORK PLEASE SEE STATEWIDE RATES

The regular worday shall be 8 hours, between 8:00 AM and 4:30 PM.

FOREMAN REQUIREMENTS:

On jobs where there are 2 Journeymen, one shall be a Foreman. The following number of Foreman, General Foreman, Assistant General Foreman and Sub-Foreman shall be required with respect to number of Journeymen on site:

- 2-10 Journeymen (1 Foreman)
- 11-20 Journeymen (1 Foreman and 1 Sub-Foreman)
- 21-30 Journeymen (1 Foreman and 2 Sub-Foremen)

SHIFT DIFFERENTIALS:

- Shift work must run for a minimum of 5 consecutive workdays.
- 2nd Shift (4:30 PM to 12:30 AM): 8 hrs. pay for 7.5 hrs. work + an additional 10% of the regular rate, inclusive of benefits.
- 3rd Shift (12:30 AM to 8:00 AM): 8 hrs. pay for 7 hrs. work + an additional 15% of the regular rate per hour, inclusive benefits.

OVERTIME:

Hours in excess of 8 per day, or outside of the regular workday, Monday through Friday, and all hours on Saturdays, shall be paid at time and one-half the regular rate, inclusive of benefits. All hours on Sundays and holidays shall be paid at double the regular rate, inclusive of benefits.

RECOGNIZED HOLIDAYS:

New Year's Day, Presidents' Day, Memorial Day, July 4th, Labor Day, Presidential Election Day, Veterans' Day, Thanksgiving Day and Christmas Day.

**NEW JERSEY DEPARTMENT OF LABOR AND WORKFORCE DEVELOPMENT
PREVAILING WAGE RATE DETERMINATION**

County - UNION

Craft: Electrician-Utility Work (North)

PREVAILING WAGE RATE

Rates are located in the "Statewide" rate package

Craft: Electrician-Utility Work (North)

APPRENTICE RATE SCHEDULE

INTERVAL	PERIOD AND RATES									
* 6 Months	60%	65%	70%	75%	80%	85%	90%			
Benefits	67% of	Appren	tice	Wage	Rate	for all	intervals			

Craft: Electrician-Utility Work (North)

COMMENTS/NOTES

Electrician-Utility Work (North) rates are located in the "Statewide" rate package.

* The apprentice wage rate is paid at the percentage of the Journeyman Lineman wage rate located in the "Statewide" rate package.

**NEW JERSEY DEPARTMENT OF LABOR AND WORKFORCE DEVELOPMENT
PREVAILING WAGE RATE DETERMINATION**

County - UNION

Craft: Electrician-Utility Work (South)

PREVAILING WAGE RATE

Rates are located in the "Statewide" rate package

Craft: Electrician-Utility Work (South)

APPRENTICE RATE SCHEDULE

INTERVAL	PERIOD AND RATES									
6 Months	28.53	30.91	33.29	35.66	38.04	40.42	42.80			
Benefits	25.01	26.41	27.83	29.24	30.65	32.05	33.47			

Craft: Electrician-Utility Work (South)

COMMENTS/NOTES

Electrician-Utility Work (South) rates are located in the "Statewide" rate package.

**NEW JERSEY DEPARTMENT OF LABOR AND WORKFORCE DEVELOPMENT
PREVAILING WAGE RATE DETERMINATION**

County - UNION

Craft: Elevator Constructor PREVAILING WAGE RATE

	03/17/18
Journeyman	W64.48 B43.36 T107.84

Craft: Elevator Constructor APPRENTICE RATE SCHEDULE

INTERVAL	PERIOD AND RATES									
Yearly	28.74	35.46	41.91	48.36						
Benefits	34.88	36.07	37.69	39.30						

Ratio of Apprentices to Journeymen - 1:1

Craft: Elevator Constructor COMMENTS/NOTES

The regular workday shall consist of either 7 or 8 hours to be established at the beginning of the project, between 7:00 AM and 4:30 PM.

OVERTIME:

For all hours worked before or after the regular workday, Monday through Friday, and all hours on Saturday and Sunday, shall be paid at double the hourly rate. Holiday pay is one days wages (8 hours) plus double the hourly rate for all hours worked.

RECOGNIZED HOLIDAYS: New Year's Day, Presidents' Day, Good Friday, Memorial Day, July 4th, Labor Day, Columbus Day, Veterans' Day, Thanksgiving Day and the day after, Christmas Day. Saturday holidays shall be observed on the previous Friday and Sunday holidays shall be observed on the following Monday.

**NEW JERSEY DEPARTMENT OF LABOR AND WORKFORCE DEVELOPMENT
PREVAILING WAGE RATE DETERMINATION**

County - UNION

Craft: Elevator Modernization & Service

PREVAILING WAGE RATE

	03/17/18
Journeyman	W50.49 B41.66 T92.15

Craft: Elevator Modernization & Service

APPRENTICE RATE SCHEDULE

INTERVAL	PERIOD AND RATES									
Yearly	28.74	27.77	32.82	37.87						
Benefits	34.81	35.13	36.58	38.03						

Ratio of Apprentices to Journeymen - 1:1

Craft: Elevator Modernization & Service

COMMENTS/NOTES

MODERNIZATION (addition, replacement, refurbishing, relocation, or changes in design or appearance, of elevator equipment in existing buildings):

- The regular workday consists of 8 hours, between 7:00 AM and 4:30 PM.

- Overtime:

Hours in excess of 8 per day, or before or after the regular workday, Monday through Friday, and all hours on Saturday and Sunday shall be paid at time and one-half the hourly rate. Holiday pay is one days wages (8 hours) plus time and one-half the hourly rate for all hours worked.

SERVICE (repair or replacement of parts for the purpose of maintaining elevator equipment in good operating condition):

- The regular workday consists of 8 hours, between 6:00 AM and 6:00 PM.

- Overtime:

Hours in excess of 8 per day, or before or after the regular workday, Monday through Friday, and all hours on Saturday shall be paid at time and one-half the hourly rate. All hours on Sunday and holidays shall be paid at double the hourly rate.

RECOGNIZED HOLIDAYS (Modernization and Service): New Year's Day, Presidents' Day, Good Friday, Memorial Day, July 4th, Labor Day, Columbus Day, Veterans' Day, Thanksgiving Day and the day after, Christmas Day. Saturday holidays shall be observed on the previous Friday and Sunday holidays shall be observed on the following Monday.

**NEW JERSEY DEPARTMENT OF LABOR AND WORKFORCE DEVELOPMENT
PREVAILING WAGE RATE DETERMINATION**

County - UNION

Craft: Glazier PREVAILING WAGE RATE

	05/15/18	05/01/19
* Leadman	W47.11 B25.06 T72.17	W49.11 B25.06 T74.17
Foreman	W48.94 B25.23 T74.17	W52.81 B23.62 T76.43
General Foreman	W50.77 B25.40 T76.17	W54.81 B23.75 T78.56
Journeyman	W45.28 B24.89 T70.17	W48.81 B23.36 T72.17

Craft: Glazier APPRENTICE RATE SCHEDULE

<u>INTERVAL</u>	<u>PERIOD AND RATES</u>									
6 Months	50%	55%		60%	65%		70%	75%		
Benefits	Intervals	1 to 2 =	9.11	Intervals	3 to 4 =	11.71	Intervals	5 to 6 =	13.20	

Ratio of Apprentices to Journeymen - 1:4

Craft: Glazier COMMENTS/NOTES

Hazard/Height Pay: +\$1.00 per hour

* When there are three (3) men working on a jobsite for three (3) days or longer, 1 Journeyman may be designated as a Leadman for the duration of the job, provided he has his OSHA certification.

FOREMAN REQUIREMENTS:

- When there are 4 or more Glaziers on a job, 1 must be designated a Foreman.
- When there are 15 or more Glaziers on a job, 1 must be designated a General Foreman.

The regular workday shall consist of 8 hours, between 7:00 AM and 5:30 PM, Monday to Friday.

SHIFT DIFFERENTIALS:

- The second shift shall receive an additional 10% of the hourly rate, per hour, and the third shift shall receive an additional 15% of the hourly rate, per hour.
- When 3 shifts are worked, the second shift shall receive 8 hours pay for 7.5 hours of work, and the third shift shall receive 8 hours pay for 7 hours of work.

OVERTIME:

Hours in excess of 8 per day, or before or after the regular workday Monday through Friday, and all hours on Saturdays shall be paid at time and one-half the regular rate. All hours on Sundays and holidays shall be paid at double the regular

**NEW JERSEY DEPARTMENT OF LABOR AND WORKFORCE DEVELOPMENT
PREVAILING WAGE RATE DETERMINATION**

County - UNION

rate.

RECOGNIZED HOLIDAYS: New Year's Day, Memorial Day, July 4th, Labor Day, General Election Day, Veterans' Day, Thanksgiving Day, Christmas Day. Saturday holiday observed the preceding Friday. Sunday holiday observed the following Monday.

**NEW JERSEY DEPARTMENT OF LABOR AND WORKFORCE DEVELOPMENT
PREVAILING WAGE RATE DETERMINATION**

County - UNION

Craft: Heat & Frost Insulator

PREVAILING WAGE RATE

	09/19/18
Foreman	W55.77 B31.92 T87.69
General Foreman	W58.11 B33.03 T91.14
Journeyman	W53.99 B31.36 T85.35

Craft: Heat & Frost Insulator

APPRENTICE RATE SCHEDULE

INTERVAL	PERIOD AND RATES									
Yearly	25.15	29.84	36.00	42.16						
Benefits	18.71	22.13	24.41	26.56						

Ratio of Apprentices to Journeymen - 1:3

Craft: Heat & Frost Insulator

COMMENTS/NOTES

NOTE: These rates apply to the installing of insulation on hot and cold mechanical systems.

The regular workday shall be 8 hours between 8:00 AM and 4:30 PM.

SHIFT DIFFERENTIAL:

- Shift work must run for a minimum of 5 consecutive workdays.
- Second Shift shall work 7.5 hours and receive 8 hours pay, at the regular rate, plus 25% per hour.
- Third Shift shall work 7 hours and receive 8 hours pay, at the regular rate, plus 30% per hour.

OVERTIME:

The first 2 hours in excess of 8 per day, hours outside of the regular workday Monday through Friday that are not shift work, and the first 10 hours on Saturday, shall be paid at time and one-half the regular rate, inclusive of benefits. All hours in excess of 10 per day, and all hours on Sunday and holidays (except Labor Day) shall be paid at double the regular rate, inclusive of benefits. All hours on Labor Day shall be paid at triple the regular rate, inclusive of benefits.

RECOGNIZED HOLIDAYS: New Year's Day, President's Day, Memorial Day, July 4th, Labor Day, Veterans' Day, Presidential Election Day, Thanksgiving Day and Christmas Day. Sunday holidays observed the following Monday.

**NEW JERSEY DEPARTMENT OF LABOR AND WORKFORCE DEVELOPMENT
PREVAILING WAGE RATE DETERMINATION**

County - UNION

Craft: Heat & Frost Insulator - Asbestos Worker

PREVAILING WAGE RATE

	09/19/18
Asbestos Helper Abatement	W36.00 B24.41 T60.41
Firestop/Hazmat	W25.68 B9.25 T34.93

Craft: Heat & Frost Insulator - Asbestos Worker

APPRENTICE RATE SCHEDULE

INTERVAL	PERIOD AND RATES									
	SEE	HEAT &	FROST	INSULAT OR						

Ratio of Apprentices to Journeymen - 1:3

Craft: Heat & Frost Insulator - Asbestos Worker

COMMENTS/NOTES

NOTE: These rates apply only to the removal of insulation materials/asbestos from mechanical systems, including containment erection and demolition, and placing material in appropriate containers.

The regular workday shall be 8 hours between 8:00 AM and 4:30 PM.

SHIFT DIFFERENTIALS:

- Shift work must run for a minimum of 5 consecutive workdays.
- The second shift shall work 7.5 hours and receive 8 hours pay at the regular rate, plus 25% per hour.
- The third shift shall work 7 hours and receive 8 hours pay at the regular rate, plus 30% per hour.

OVERTIME: The first 2 hours in excess of 8 per day, hours outside of the regular workday Monday through Friday that are not shift work, and the first 10 hours on Saturday, shall be paid at time and one-half the regular rate, inclusive of benefits. All hours in excess of 10 per day, and all hours on Sunday and holidays (except Labor Day) shall be paid at double the regular rate, inclusive of benefits. All hours on Labor Day shall be paid at triple the regular rate, inclusive of benefits.

RECOGNIZED HOLIDAYS: New Year's Day, Presidents' Day, Memorial Day, July 4th, Labor Day, Veterans' Day, Presidential Election Day, Thanksgiving Day and Christmas Day. Sunday holidays observed the following Monday.

**NEW JERSEY DEPARTMENT OF LABOR AND WORKFORCE DEVELOPMENT
PREVAILING WAGE RATE DETERMINATION**

County - UNION

Craft: Ironworker PREVAILING WAGE RATE

	07/10/18	07/01/19	07/01/20
Rod /Fence Foreman	W44.39 B46.12 T90.51	W0.00 B0.00 T92.51	W0.00 B0.00 T94.26
Rod/Fence Journeyman	W41.39 B46.12 T87.51	W0.00 B0.00 T89.51	W0.00 B0.00 T91.26
Structural Foreman	W46.44 B46.12 T92.56	W0.00 B0.00 T94.56	W0.00 B0.00 T96.56
Structural Journeyman	W43.44 B46.12 T89.56	W0.00 B0.00 T91.56	W0.00 B0.00 T93.56

Craft: Ironworker APPRENTICE RATE SCHEDULE

<u>INTERVAL</u>	<u>PERIOD AND RATES</u>									
6 Months	50%	60%		Yearly	70%	80%	90%			

Ratio of Apprentices to Journeymen - 1:4

Craft: Ironworker COMMENTS/NOTES

HAZARDOUS WASTE WORK: On hazardous waste removal work on a state or federally designated hazardous waste site where the Ironworker is required to wear Level A,B, or C personal protection: + \$3.00 per hour

The regular workday consists of 8 hours between 6:00 AM and 4:30 PM.

FOREMAN REQUIREMENTS:

When there are 2 or more Ironworkers on a job, 1 shall be designated a Foreman.

SHIFT DIFFERENTIALS:

- When a 2 shift schedule is established, the first, or day shift , shall be established on an 8 hour basis .The second shift shall be established on an 8 hour basis, and receive the regular rate plus 15%.

- When a three shift schedule is established, the first shift shall be established on an 8 hour basis, the second shift on a 7.5 hour basis, and the third shift on a 7 hour basis. The first shift shall receive the regular hourly rate, the second shift shall receive the regular rate plus 15%, and the third shift shall receive the regular rate plus 20%.

- When there is no day shift, and a second or third shift is established, it shall be established on an 8 hour basis.

- When an irregular shift is established for the Ironworker (Structural) classification, the rate shall be paid at time and one-half the regular rate, inclusive of benefits. When an irregular shift is established for the Rod/Fence classification, the shift shall be established on an 8 hour basis and receive the regular rate, plus 20%.

OVERTIME:

**NEW JERSEY DEPARTMENT OF LABOR AND WORKFORCE DEVELOPMENT
PREVAILING WAGE RATE DETERMINATION**

County - UNION

- All hours in excess of 8 per day, or before or after an established shift that are not shift work, and all hours on Saturday, shall be paid at time and one-half the regular rate, inclusive of benefits. All hours on Sunday and holidays shall be paid at double the hourly rate, inclusive of benefits. Saturday may be used as a make-up day for a day lost to inclement weather. If Saturday is not a make-up day, all hours on Saturday shall be paid at time and one-half the hourly rate, inclusive of benefits.

- Four 10-hour days may be worked, Monday to Thursday, at straight time. Friday may be used as a make-up day for a day lost to inclement weather. If Friday is not a make-up day, all hours on Friday shall be paid at time and one-half the hourly rate, inclusive of benefits.

RECOGNIZED HOLIDAYS: New Year's Day, Presidents' Day, Memorial Day, July 4th, Labor Day, Presidential Election Day, Veterans Day, Thanksgiving Day, Christmas Day.

**NEW JERSEY DEPARTMENT OF LABOR AND WORKFORCE DEVELOPMENT
PREVAILING WAGE RATE DETERMINATION**

County - UNION

Craft: Laborer - Asbestos & Hazardous Waste Removal

PREVAILING WAGE RATE

	08/01/18
Journeyman (Handler)	W31.48 B22.31 T53.79

Craft: Laborer - Asbestos & Hazardous Waste Removal

APPRENTICE RATE SCHEDULE

INTERVAL	PERIOD AND RATES									
Yearly	18.89	22.04	25.18	28.33						
Benefits	20.66	for	all	intervals						

Ratio of Apprentices to Journeymen - *

* Ratio of apprentices to journeymen shall not be more than one apprentice for the first journeyman and no more than (1) apprentice for each additional three (3) journeymen.

Craft: Laborer - Asbestos & Hazardous Waste Removal

COMMENTS/NOTES

NOTE: These rates apply to work in connection with Asbestos, Radiation, Hazardous Waste, Lead, Chemical, Biological, Mold Remediation and Abatement.

The regular workday shall be 8 hours.

OVERTIME:

- Hours in excess of 8 per day, Monday through Saturday, and all hours on Sunday and holidays shall be paid at time and one-half the regular rate.
- Benefits on ALL overtime hours shall be paid at straight time.

RECOGNIZED HOLIDAYS: New Year's Day, President's Day, Good Friday, Easter, Memorial Day, July 4th, Labor Day, Presidential Election Day, Veterans' Day, Thanksgiving Day, Christmas Day. (Holidays start at 12:00 am).

**NEW JERSEY DEPARTMENT OF LABOR AND WORKFORCE DEVELOPMENT
PREVAILING WAGE RATE DETERMINATION**

County - UNION

Craft: Laborer - Building

PREVAILING WAGE RATE

	05/15/18
Class A Journeyman	W33.45 B29.12 T62.57
Class B Journeyman	W32.95 B29.12 T62.07
Class C Journeyman	W28.01 B29.12 T57.13
Foreman	W37.63 B29.12 T66.75
General Foreman	W41.81 B29.12 T70.93

Craft: Laborer - Building

APPRENTICE RATE SCHEDULE

<u>INTERVAL</u>	<u>PERIOD AND RATES</u>									
	60%	70%	80%	90%						
6 Months										
Benefit	25.87	25.87	25.87	25.87						

Ratio of Apprentices to Journeymen - *

* Ratio of apprentices to journeymen shall not be more than one apprentice for the first journeyman and no more than (1) apprentice for each additional three (3) journeymen.

Craft: Laborer - Building

COMMENTS/NOTES

CLASS A: Specialist laborer including mason tender or concrete pour crew; scaffold builder (scaffolds up to 14 feet in height); operator of forklifts, Bobcats (or equivalent machinery), jack hammers, tampers, motorized tampers and compactors, vibrators, street cleaning machines, hydro demolition equipment, riding motor buggies, conveyors, burners; and nozzlemen on gunite work.

CLASS B: Basic laborer - includes all laborer work not listed in Class A or Class C.

CLASS C: Janitorial-type light clean-up work associated with the TURNOVER of a project, or part of a project, to the owner. All other clean-up work is Class B.

The regular workday shall be 8 hours between 6:00 AM and 6:00 PM.

SHIFT DIFFERENTIALS:

- Shift work must run for a minimum of 5 consecutive workdays.
- When a 2-shift schedule is worked, including a day shift, both shifts shall be established on the basis of 8 hours pay for 8 hours worked. The second shift shall receive the regular rate plus an additional 10%.
- When a 3-shift schedule is worked, the day shift shall be established on the basis of 8 hours pay for 8 hours worked, the second shift shall be established on the basis of 8 hours pay for 7.5 hours worked, and the third shift shall be established

**NEW JERSEY DEPARTMENT OF LABOR AND WORKFORCE DEVELOPMENT
PREVAILING WAGE RATE DETERMINATION**

County - UNION

on the basis of 8 hours pay for 7 hours worked. The day shift shall receive the regular rate, the second shift shall receive the regular rate plus an additional 10%, and the third shift shall receive the regular rate plus an additional 15%.

- When a second or third shift is worked with no day shift, the second or third shift shall be established on the basis of 8 hours pay for 8 hours worked. The second shift shall receive the regular rate plus an additional 10%, and the third shift shall receive the regular rate plus an additional 15%.

OVERTIME:

- Hours in excess of 8 per day, or outside the regular workday that are not shift work, Monday through Friday, and all hours on Saturdays shall be paid at time and one-half the regular rate. Saturday may be used as a make-up day (paid at straight time) for a day lost to inclement weather, or for a holiday that is observed during the work week, Monday through Friday. All hours on Sundays and holidays shall be paid at double the regular rate.

- Four 10-hour days may be worked Monday to Thursday, at straight time, with Friday used a make-up day for a day lost to inclement weather. If Friday is not a make-up day, all hours on Friday shall be paid at time and one-half the regular rate.

- Benefits on ALL overtime hours shall be paid at time and one-half.

RECOGNIZED HOLIDAYS: New Year's Day, Presidents' Day, Memorial Day, July 4th, Labor Day, Presidential Election Day, Veterans' Day, Thanksgiving Day, Christmas Day. Sunday holidays observed the following Monday.

**NEW JERSEY DEPARTMENT OF LABOR AND WORKFORCE DEVELOPMENT
PREVAILING WAGE RATE DETERMINATION**

County - UNION

Craft: Laborer - Heavy & General

PREVAILING WAGE RATE

Rates are located in the
"Statewide" rate package

Craft: Laborer - Heavy & General

APPRENTICE RATE SCHEDULE

INTERVAL	PERIOD AND RATES									
1000 Hours	60%	70%	80%	90%						
Benefit	20.28	for	all	intervals						

Ratio of Apprentices to Journeymen - *

* No more than 1 apprentice for the first journeyman and no more than 1 apprentice for each additional 3 journeymen.

Craft: Laborer - Heavy & General

COMMENTS/NOTES

As of 3-1-19, benefits shall be \$21.03.

As of 3-1-20, benefits shall be \$21.78.

Heavy & General Laborer rates are located in the "Statewide" rate package.

**NEW JERSEY DEPARTMENT OF LABOR AND WORKFORCE DEVELOPMENT
PREVAILING WAGE RATE DETERMINATION**

County - UNION

Craft: Laborer-Residential and Modular Construction

PREVAILING WAGE RATE

	04/26/18
* Skilled Tradesman (only applies to Modular Construction)	W25.85 B5.45 T31.30
Foreman (person directing crew, regardless of his skill classification)	W29.85 B5.45 T35.30
Laborer	W21.85 B5.45 T27.30
Laborer (for single family and stand-alone duplex owned by single owner)	W16.35 B2.95 T19.30

Craft: Laborer-Residential and Modular Construction

APPRENTICE RATE SCHEDULE

<u>INTERVAL</u>	<u>PERIOD AND RATES</u>									
	As shown	800 hours	600 hours	600 hours						
wage & benefits	70%	80%	90%							

Ratio of Apprentices to Journeymen-

One (1) apprentice shall be allowed for the first journeyman on site and no more than one (1) additional apprentice for each additional three (3) journeymen on site.

Craft: Laborer-Residential and Modular Construction

COMMENTS/NOTES

* SKILLED TRADESMAN- any worker doing work not typically done by a Building Laborer. Some examples are installing interior doors, sheet rock, hooking up appliances, installing light fixtures, installing railing systems, etc. Please note where local building codes require that certain work be performed under the supervision of a licensed tradesman (i.e. Plumber, Electrician, etc.) Laborers shall work under such supervision.

RESIDENTIAL CONSTRUCTION- All residential construction (not commercial), single-family, stand-alone duplex houses, townhouses and multi-family buildings of not more than four (4) floors, including basement levels. Please note the construction must be residential in nature for ALL FLOORS at an elevation of no more than FOUR (4) FLOORS, INCLUDING BASEMENT. In addition, barracks and dormitories are not considered residential projects.

MODULAR RESIDENTIAL CONSTRUCTION- all aspects of modular residential construction (not commercial) at the site of installation of structures of no more than four (4) stories, including all excavation and site preparation, footings and foundation systems whether poured on-site or prefabricated, all underground waterproofing, underground utilities, concrete slabs, sidewalks, driveways, paving, hardscape and landscaping. Please note the construction must be residential in nature for ALL STORIES at an elevation of no more than FOUR (4) STORIES. All work performed by the Set Crew (the crew of workers who set the modular boxes on the foundation), including the rigging, setting, attaching and assembly of all modules and structural members, preparation of the foundation to accept modules, such as sill plates, connection of all in-module and under-module connections including, but not limited to, plumbing, electrical, HVAC, fire suppression, CATS,

**NEW JERSEY DEPARTMENT OF LABOR AND WORKFORCE DEVELOPMENT
PREVAILING WAGE RATE DETERMINATION**

County - UNION

telephone, television/internet, and fiber optic, the building or installation of any porches or decks regardless of material or method of construction, the on-site installation of, or completion of any roof system, doors, windows and fenestrations, including flashing, gutter and soffit systems, waterproofing, insulation and interior and exterior trim work, and painting. Please note that modular construction does not include on-site stick built construction, tip up construction or panel built construction.

The regular workday shall be 8 hours between 6:00 AM and 6:00 PM.

OVERTIME:

Hours worked in excess of 8 per day/40 per week, Monday through Saturday, and all hours worked on Sunday and holidays shall be paid at time and one-half the hourly rate.

RECOGNIZED HOILDAYS:

New Year's Day, Martin Luther King Day, Memorial Day, July 4th, Labor Day, Thanksgiving Day and Christmas Day.

**NEW JERSEY DEPARTMENT OF LABOR AND WORKFORCE DEVELOPMENT
PREVAILING WAGE RATE DETERMINATION**

County - UNION

Craft: Millwright PREVAILING WAGE RATE

	11/01/18
Foreman	W57.03 B33.67 T90.70
Journeyman	W49.59 B29.36 T78.95

Craft: Millwright APPRENTICE RATE SCHEDULE

INTERVAL	PERIOD AND RATES									
6 Months	40%	45%	50%	55%	60%	65%	70%	75%	85%	95%
Benefits	58% of	Appren	tice	Wage	Rate	for all	intervals	+ \$.60		

Ratio of Apprentices to Journeymen - 1:3

Craft: Millwright COMMENTS/NOTES

FOREMAN REQUIREMENTS:

- When there are 2 or more Millwrights on a job, 1 shall be designated as a Foreman.
- When there are 21 or more Millwrights on a job, 2 shall be designated as Foremen.

The regular workday shall consist of 8 hours, starting between 7:00 AM and 9:00 AM.

SHIFT DIFFERENTIALS:

- When a 2 shift schedule (including a day shift) is established, the day shift shall be established on an 8 hour basis. The second shift shall be established on an 8 hour basis, and receive the regular rate plus 15%, inclusive of benefits.
- When a three shift schedule is established, the first shift shall be established on an 8 hour basis, the second shift on a 7.5 hour basis, and the third shift on a 7 hour basis. The first shift shall receive the regular hourly rate, the second shift shall receive the regular rate plus 15% and the third shift shall receive the regular rate plus 20%, inclusive of benefits.
- When there is no day shift, and a second or third shift is established, it shall be established on an 8 hour basis. The second shift shall receive the regular rate plus 15% and the third shift shall receive the regular rate plus 20%, inclusive of benefits.

OVERTIME:

- All hours in excess of 8 per day, or before or after an established shift that are not shift work, and all hours on Saturdays shall be paid at time and one-half the hourly rate, inclusive of benefits. All hours on Sundays and holidays shall be paid at double the hourly rate, inclusive of benefits.
- Four 10-hour days may be worked, Monday to Thursday, at straight time. Friday may be used as a make-up day for a day lost due to inclement weather. If Friday is not a make-up day, all hours on Friday shall be paid at time and one-half the hourly rate, inclusive of benefits.

RECOGNIZED HOLIDAYS: New Year's Day, Presidents' Day, Memorial Day, July 4th, Labor Day, Presidential Election Day, Veterans' Day, Thanksgiving Day, Christmas Day. Sunday holidays will be observed the following Monday.

**NEW JERSEY DEPARTMENT OF LABOR AND WORKFORCE DEVELOPMENT
PREVAILING WAGE RATE DETERMINATION**

County - UNION

Craft: Operating Engineer - Field Engineer

PREVAILING WAGE RATE

Rates are located in the
"Statewide" rate package

Craft: Operating Engineer - Field Engineer

APPRENTICE RATE SCHEDULE

INTERVAL	PERIOD AND RATES									
Yearly	70%	75%	of Rod/	Chainman	Wage					
Yearly			80%	90%	Transit/	Instrument	man	Wage		

Ratio of Apprentices to Journeymen - *

* No more than 1 Field Engineer Apprentice per Survey Crew.

Craft: Operating Engineer - Field Engineer

COMMENTS/NOTES

Operating Engineer - Field Engineer rates are located in the "Statewide" rate package.

**NEW JERSEY DEPARTMENT OF LABOR AND WORKFORCE DEVELOPMENT
PREVAILING WAGE RATE DETERMINATION**

County - UNION

Craft: Painter - Bridges

PREVAILING WAGE RATE

	05/04/17
Foreman	W59.13 B27.67 T86.80
General Foreman	W61.13 B27.67 T88.80
Journeyman	W54.13 B27.67 T81.80

Craft: Painter - Bridges

APPRENTICE RATE SCHEDULE

INTERVAL	PERIOD AND RATES									
	40%	50%			60%	70%		80%	90%	
6 Months										
Benefits	Intervals	1 to 2 =	8.88	Intervals	3 to 4 =	10.81	Intervals	5 to 6 =	13.48	

Ratio of Apprentices to Journeymen - 1:4

Craft: Painter - Bridges

COMMENTS/NOTES

These rates apply to: All bridges that span waterways, roadways, railways and canyons. All tunnels, overpasses, viaducts and all appurtenances.

FOREMEN REQUIREMENTS:

- When there are 4 or more Painters on a job, 1 shall be designated a Foreman.
- When there are 15 or more Painters on a job, 1 shall be designated a General Foreman.

The regular workday shall consist of 8 hours between 7:00 AM and 5:30 PM.

SHIFT DIFFERENTIALS:

- The second shift shall receive an additional 10% of the hourly rate, per hour, and the third shift shall receive an additional 15% of the hourly rate, per hour.

OVERTIME:

- Hours in excess of 8 per day, Monday through Friday, and all hours on Saturdays and Sundays shall be paid at time and one-half the regular rate. All hours on holidays shall be paid at double the regular rate.
- Saturday or Sunday may be used to make up a day lost to inclement weather, at straight time.
- Four 10-hour days may be worked, at straight time, Monday through Friday.

RECOGNIZED HOLIDAYS: New Year's Day, President's Day, Memorial Day, July 4th, Labor Day, Presidential Election Day, Veterans' Day, Thanksgiving Day, Christmas Day. Saturday holiday observed the preceding Friday. Sunday holiday observed the following Monday.

**NEW JERSEY DEPARTMENT OF LABOR AND WORKFORCE DEVELOPMENT
PREVAILING WAGE RATE DETERMINATION**

County - UNION

Craft: Painter - Line Striping

PREVAILING WAGE RATE

	12/01/17
Apprentice (1st year)	W25.45 B11.00 T36.45
Apprentice (2nd year)	W29.45 B18.00 T47.45
Foreman (Charge Person)	W37.60 B18.17 T55.77
Journeyman 1 (at least 1 year of working exp. as a journeyman)	W33.33 B18.17 T51.50
Journeyman 2 (at least 2 years of working exp. as a journeyman)	W37.10 B18.17 T55.27

Craft: Painter - Line Striping

COMMENTS/NOTES

OVERTIME:

Hours in excess of 8 per day, Monday through Saturday, and all hours on Sundays and holidays shall be paid at time and one-half the hourly rate.

RECOGNIZED HOLIDAYS: New Year's Day, Presidents' Day, Memorial Day, July 4th, Labor Day, Veterans Day, Thanksgiving Day and Christmas Day. Veterans Day may be substituted for the day after Thanksgiving.

**NEW JERSEY DEPARTMENT OF LABOR AND WORKFORCE DEVELOPMENT
PREVAILING WAGE RATE DETERMINATION**

County - UNION

Craft: Painter - New Construction

PREVAILING WAGE RATE

	05/17/18	05/01/19	05/01/20
Foreman	W43.80 B24.35 T68.15	W45.45 B24.35 T69.80	W47.45 B24.35 T71.80
General Foreman	W47.78 B24.67 T72.45	W49.43 B24.67 T74.10	W51.43 B24.67 T76.10
Journeyman	W39.82 B24.04 T63.86	W41.47 B24.04 T65.51	W43.47 B24.04 T67.51

Craft: Painter - New Construction

APPRENTICE RATE SCHEDULE

INTERVAL	PERIOD AND RATES									
	40%	45%	55%	65%	70%	75%	80%	80%		
6 Months										
Benefits	8.05	8.05	10.05	10.05	11.05	11.05	14.05	14.05		

Ratio of Apprentices to Journeymen - 1:4

Craft: Painter - New Construction

COMMENTS/NOTES

Spraying, sandblasting, lead abatement, work on tanks or stacks, work performed above 3 stories or 30 feet in height, or using swing scaffolds requires an additional 10% of the wage rate.

FOREMEN REQUIREMENTS:

- When there are 4 or more Painters on a job, 1 shall be designated a Foreman.
- When there are 15 or more Painters on a job, 1 shall be designated a General Foreman.

The regular workday shall consist of 8 hours between 7:00 AM and 5:30 PM.

SHIFT DIFFERENTIALS:

- The second shift shall receive an additional 10% of the hourly rate, per hour, and the third shift shall receive an additional 15% of the hourly rate, per hour.

OVERTIME:

- Hours in excess of 8 per day, or before or after the regular workday, Monday through Friday, and all hours on Saturdays shall be paid at time and one-half the regular rate. All hours on Sundays and holidays shall be paid at double the regular rate.
- Saturday or Sunday may be used to make up a day lost to inclement weather, at straight time.
- Four 10-hour days may be worked, at straight time, Monday through Friday.

RECOGNIZED HOLIDAYS: New Year's Day, President's Day, Memorial Day, July 4th, Labor Day, General Election Day, Veterans' Day, Thanksgiving Day, Christmas Day.

**NEW JERSEY DEPARTMENT OF LABOR AND WORKFORCE DEVELOPMENT
PREVAILING WAGE RATE DETERMINATION**

County - UNION

Craft: Painter - Repainting

PREVAILING WAGE RATE

	05/17/18	05/01/19	05/01/20
Foreman	W32.27 B19.91 T52.18	W33.07 B19.95 T53.02	W33.92 B19.95 T53.87
General Foreman	W35.20 B20.06 T55.26	W36.00 B20.10 T56.10	W36.85 B20.10 T56.95
Journeyman	W29.34 B19.77 T49.11	W30.14 B19.77 T49.91	W30.99 B19.77 T50.76

Craft: Painter - Repainting

APPRENTICE RATE SCHEDULE

INTERVAL	PERIOD AND RATES									
	SEE	Painter	NEW	CONSTR	TION					
				UC						

Ratio of Apprentices to Journeymen - 1:4

Craft: Painter - Repainting

COMMENTS/NOTES

NOTE: These rates may only be used on jobs where no major alterations (only doing painting and carpeting with nothing else being changed in the office or on the project) occur, and where not more than 3 other trades are present on the job, but may NOT, under any circumstances, be used for work on bridges, stacks, elevated tank, or generating stations.

Spraying, sandblasting, lead abatement, work on tanks or stacks, work performed above 3 stories or 30 feet in height, or using swing scaffolds requires an additional 10% of the wage rate.

FOREMEN REQUIREMENTS:

- When there are 4 or more Painters on a job, 1 shall be designated a Foreman.
- When there are 15 or more Painters on a job, 1 shall be designated a General Foreman.

OVERTIME:

- Hours in excess of 8 per day and 40 per week shall be paid at time and one-half the regular rate. All hours on Sundays and holidays shall be paid at double the regular rate.
- Four 10-hour days may be worked, at straight time, Monday through Sunday.

RECOGNIZED HOLIDAYS: New Year's Day, President's Day, Memorial Day, July 4th, Labor Day, General Election Day, Veterans' Day, Thanksgiving Day, Christmas Day.

NEW JERSEY DEPARTMENT OF LABOR AND WORKFORCE DEVELOPMENT
PREVAILING WAGE RATE DETERMINATION

County - UNION

Craft: Painter- Containment

PREVAILING WAGE RATE

	05/04/17
Journeyman	W35.18 B24.75 T59.93

Craft: Painter- Containment

COMMENTS/NOTES

NOTE: These rates shall require no painting, but used in a supporting capacity only, such as wrapping, boxing, fencing, etc. on tanks.

The regular workday shall consist of 8 hours between 7:00 AM and 5:30 PM.

SHIFT DIFFERENTIALS:

- The second shift shall receive an additional 10% of the hourly rate, per hour, and the third shift shall receive an additional 15% of the hourly rate, per hour.

OVERTIME:

- Hours in excess of 8 per day, Monday through Friday, and all hours on Saturdays and Sundays shall be paid at time and one-half the regular rate. All hours on holidays shall be paid at double the regular rate..

- Four 10-hour days may be worked, at straight time, Monday through Friday.

RECOGNIZED HOLIDAYS: New Year's Day President's Day, Memorial Day, July 4th, Labor Day, Presidential Election Day, Veterans' Day, Thanksgiving Day, Christmas Day. Saturday holiday observed the preceding Friday. Sunday holiday observed the following Monday.

**NEW JERSEY DEPARTMENT OF LABOR AND WORKFORCE DEVELOPMENT
PREVAILING WAGE RATE DETERMINATION**

County - UNION

Craft: Painter-Elevated Water Tanks

PREVAILING WAGE RATE

	05/04/17
Foreman	W48.92 B24.92 T73.84
General Foreman	W50.92 B24.92 T75.84
Journeyman	W43.92 B24.92 T68.84

Craft: Painter-Elevated Water Tanks

APPRENTICE RATE SCHEDULE

INTERVAL	PERIOD AND RATES									
	SEE	PAINTER	BRIDGES							

Craft: Painter-Elevated Water Tanks

COMMENTS/NOTES

These rates apply to: All new and repaint elevated water tanks (interior and exterior).

FOREMEN REQUIREMENTS:

- When there are 4 or more Painters on a job, 1 shall be designated a Foreman.
- When there are 15 or more Painters on a job, 1 shall be designated a General Foreman.

The regular workday shall consist of 8 hours between 7:00 AM and 5:30 PM.

SHIFT DIFFERENTIALS:

- The second shift shall receive an additional 10% of the hourly rate, per hour, and the third shift shall receive an additional 15% of the hourly rate, per hour.

OVERTIME:

- Hours in excess of 8 per day, Monday through Friday, and all hours on Saturdays and Sundays shall be paid at time and one-half the regular rate. All hours on holidays shall be paid at double the regular rate.
- Saturday or Sunday may be used to make up a day lost to inclement weather, at straight time.
- Four 10-hour days may be worked, at straight time, Monday through Friday.

RECOGNIZED HOLIDAYS: New Year's Day, President's Day, Memorial Day, July 4th, Labor Day, Presidential Election Day, Veterans' Day, Thanksgiving Day, Christmas Day. Saturday holiday observed the preceding Friday. Sunday holiday observed the following Monday.

**NEW JERSEY DEPARTMENT OF LABOR AND WORKFORCE DEVELOPMENT
PREVAILING WAGE RATE DETERMINATION**

County - UNION

Craft: Painter-Structural Steel

PREVAILING WAGE RATE

	05/04/17
Foreman	W47.87 B25.27 T73.14
General Foreman	W49.87 B25.27 T75.14
Journeyman	W42.87 B25.27 T68.14

Craft: Painter-Structural Steel

APPRENTICE RATE SCHEDULE

INTERVAL	PERIOD AND RATES									
	SEE	PAINTER	BRIDGES							

Craft: Painter-Structural Steel

COMMENTS/NOTES

These rates apply to: All work in power plants (any aspect). On steeples, on dams, on hangers, transformers, substations, etc. and on open steel, whether new or repaint. All new work (excluding traditional commercial painting work) in refineries, tank farms, water/sewerage treatment facilities and on pipelines.

FOREMEN REQUIREMENTS:

- When there are 4 or more Painters on a job, 1 shall be designated a Foreman.
- When there are 15 or more Painters on a job, 1 shall be designated a General Foreman.

The regular workday shall consist of 8 hours between 7:00 AM and 5:30 PM.

SHIFT DIFFERENTIALS:

- The second shift shall receive an additional 10% of the hourly rate, per hour, and the third shift shall receive an additional 15% of the hourly rate, per hour.

OVERTIME:

- Hours in excess of 8 per day, Monday through Friday, and all hours on Saturdays and Sundays shall be paid at time and one-half the regular rate. All hours on holidays shall be paid at double the regular rate.
- Saturday or Sunday may be used to make up a day lost to inclement weather, at straight time.
- Four 10-hour days may be worked, at straight time, Monday through Friday.

RECOGNIZED HOLIDAYS: New Year's Day, President's Day, Memorial Day, July 4th, Labor Day, Presidential Election Day, Veterans' Day, Thanksgiving Day, Christmas Day. Saturday holiday observed the preceding Friday. Sunday holiday observed the following Monday.

**NEW JERSEY DEPARTMENT OF LABOR AND WORKFORCE DEVELOPMENT
PREVAILING WAGE RATE DETERMINATION**

County - UNION

Craft: Paperhanger - New Construction

PREVAILING WAGE RATE

	05/17/18	05/01/19	05/01/20
Foreman	W45.82 B24.11 T69.93	W46.75 B24.11 T70.86	W47.68 B24.11 T71.79
Journeyman	W40.75 B24.11 T64.86	W41.68 B24.11 T65.79	W42.61 B24.11 T66.72

Craft: Paperhanger - New Construction

APPRENTICE RATE SCHEDULE

INTERVAL	PERIOD AND RATES									
	SEE	PAINTER	NEW	CONSTR	TION					
				UC						

Ratio of Apprentices to Journeymen - 1:4

Craft: Paperhanger - New Construction

COMMENTS/NOTES

FOREMEN REQUIREMENTS:

- When there are 4 or more Paperhangers on a job, 1 shall be designated a Foreman.

The regular workday shall consist of 8 hours between 7:00 AM and 5:30 PM.

SHIFT DIFFERENTIALS:

- The second shift shall receive an additional 10% of the hourly rate, per hour, and the third shift shall receive an additional 15% of the hourly rate, per hour.

OVERTIME:

- Hours in excess of 8 per day, Monday through Friday, and all hours on Saturdays shall be paid at time and one-half the regular rate. All hours on Sundays and holidays shall be paid at double the regular rate.

- Saturday or Sunday may be used to make up a day lost to inclement weather, at straight time.

- Four 10-hour days may be worked, at straight time, Monday through Friday.

RECOGNIZED HOLIDAYS: New Year's Day, President's Day, Memorial Day, July 4th, Labor Day, General Election Day, Veterans' Day, Thanksgiving Day, Christmas Day.

**NEW JERSEY DEPARTMENT OF LABOR AND WORKFORCE DEVELOPMENT
PREVAILING WAGE RATE DETERMINATION**

County - UNION

Craft: Paperhanger - Renovation

PREVAILING WAGE RATE

	05/17/18	05/01/19	05/01/20
Foreman	W33.11	W34.13	W35.15
	B19.81	B19.81	B19.81
	T52.92	T53.94	T54.96
Journeyman	W30.10	W31.03	W31.96
	B19.81	B19.81	B19.81
	T49.91	T50.84	T51.77

Craft: Paperhanger - Renovation

APPRENTICE RATE SCHEDULE

INTERVAL	PERIOD AND RATES									
		SEE	PAINTER	NEW	CONSTR	TION				
					UC					

Ratio of Apprentices to Journeymen - 1:4

Craft: Paperhanger - Renovation

COMMENTS/NOTES

NOTE: These rates may only be used on jobs where no major alterations occur, and where not more than 3 other trades are present on the job, but may NOT, under any circumstances, be used for work on bridges, stacks, elevated tanks, or generating stations.

FOREMEN REQUIREMENTS:

- When there are 4 or more Paperhangers on a job, 1 shall be designated a Foreman.

OVERTIME:

- Hours in excess of 8 per day and 40 per week shall be paid at time and one-half the regular rate.
- Four 10-hour days may be worked, at straight time, Monday through Sunday.

**NEW JERSEY DEPARTMENT OF LABOR AND WORKFORCE DEVELOPMENT
PREVAILING WAGE RATE DETERMINATION**

County - UNION

Craft: Pipefitter PREVAILING WAGE RATE

	05/01/18	05/01/19
Foreman	W53.23 B42.41 T95.64	W0.00 B0.00 T97.82
Journeyman	W49.48 B39.43 T88.91	W0.00 B0.00 T91.13

Craft: Pipefitter APPRENTICE RATE SCHEDULE

INTERVAL	PERIOD AND RATES									
Yearly	35%	45%	55%	65%	75%					
Benefit	18.22	22.15	24.59	27.04	29.49					

Ratio of Apprentices to Journeymen - 1:5

Craft: Pipefitter COMMENTS/NOTES

FOREMAN REQUIREMENTS:

- When there are 2 or more Journeyman Pipefitters on a job, 1 shall be designated a Foreman.
- There shall be a Foreman for every 8 Journeyman Pipefitters on a job.

The regular workday shall be 8 hours between 7:00 AM and 3:30 PM.

SHIFT DIFFERENTIAL:

- 2nd Shift (3:30 PM-11:30 PM) shall work 7.5 hours and receive 8 hours pay at the regular rate, plus 10% per hour on the total rate.
- 3rd Shift (11:30 PM-7:00 AM) shall work 7 hours and receive 8 hours pay at the regular rate, plus 15% per hour on the total rate.

OVERTIME:

- All hours worked in excess of 8 per day, Monday through Friday, and all hours worked on Saturday, shall be paid at time and one-half, inclusive of benefits. All hours on Sunday and holidays shall be paid at double time, inclusive of benefits.
- By mutual agreement, employees may work four 10-hour days, Monday to Thursday, at straight time rate. Friday may be used as a make-up day for a day lost to inclement weather, and may be paid at straight time. If Friday is not a make-up day, the first 8 hours shall be paid at time and one-half, inclusive of benefits; hours in excess of 8 shall be paid at double time, inclusive of benefits.

SHIFT DIFFERENTIAL (Maintenance Work Only):

- 2nd Shift (3:30 PM-11:30 PM) shall work 7.5 hours and receive 8 hours pay at the regular rate, plus 10% per hour on the total rate.
- 3rd Shift (11:30 PM-7:00 AM) shall work 7 hours and receive 8 hours pay at the regular rate, plus 15% per hour on the total rate.

OVERTIME (Maintenance Work Only):

- All hours in excess of 8 per day, Monday through Saturday, shall be paid at time and one-half, inclusive of benefits. All

**NEW JERSEY DEPARTMENT OF LABOR AND WORKFORCE DEVELOPMENT
PREVAILING WAGE RATE DETERMINATION**

County - UNION

hours on Sundays and holidays shall be paid at double time, inclusive of benefits.

NOTE: Maintenance work is work to repair, restore, or improve the efficiency of existing facilities. This does NOT apply to ANY new construction.

RECOGNIZED HOLIDAYS: New Year's Day, Presidents' Day, Memorial Day, July 4th, Labor Day, Presidential Election Day, Veterans' Day, Thanksgiving Day, Christmas Day. Sunday holidays are observed the following Monday.

**NEW JERSEY DEPARTMENT OF LABOR AND WORKFORCE DEVELOPMENT
PREVAILING WAGE RATE DETERMINATION**

County - UNION

Craft: Plasterer

PREVAILING WAGE RATE

See Bricklayer, Stone Mason Rates

Craft: Plasterer

COMMENTS/NOTES

See BRICKLAYER, STONE MASON Rates

**NEW JERSEY DEPARTMENT OF LABOR AND WORKFORCE DEVELOPMENT
PREVAILING WAGE RATE DETERMINATION**

County - UNION

Craft: Plumber PREVAILING WAGE RATE

	05/01/18
Foreman	W58.41 B34.66 T93.07
General Foreman	W62.19 B34.66 T96.85
Journeyman	W54.08 B34.66 T88.74

Craft: Plumber APPRENTICE RATE SCHEDULE

INTERVAL	PERIOD AND RATES									
	30%	45%	55%	65%	75%					
Yearly										
Benefits	10.15	15.23	18.61	22.00	25.38					

Ratio of Apprentices to Journeymen - *

* Employers may employ 1 apprentice on any job where 1 or 2 journeymen are employed. Thereafter, 1 apprentice may be employed for every 4 journeymen.

Craft: Plumber COMMENTS/NOTES

APPRENTICE RATE SCHEDULE AS OF 5-1-18:

INTERVAL	PERIOD AND RATES				
Yearly	30%	45%	55%	65%	75%
Benefits	13.35	19.71	21.51	23.34	25.13

FOREMAN REQUIREMENTS:

- On any job having 2 or more Plumbers, 1 must be designated a Foreman.
- On any job having 9 or more Plumbers, 2 shall be designated as Foremen.

The regular workday shall consist of 8 hours between 7:00 AM and 4:30 PM.

SHIFT DIFFERENTIALS:

- Shift work must continue for a minimum of 5 consecutive workdays.
- When two shifts are worked, the second shift shall work 7.5 hours and receive 8 hours pay, at a rate equal to the hourly rate plus 10%, inclusive of benefits.
- When a third shift is worked, the third shift shall work 7 hours and receive 8 hours pay, at a rate equal to the hourly rate plus 15%, inclusive of benefits.

OVERTIME:

- All hours in excess of 8 per day, or before of after the regular workday that are not shift work, Monday through Friday, and all hours on Saturday, shall be paid at time and one-half the regular rate, inclusive of benefits. All hours on Sunday and holidays, shall be paid at double the hourly rate, inclusive of benefits.
- Four 10-hour days may be worked, Monday to Thursday, at straight time. Friday may be used as a make-up day for a

**NEW JERSEY DEPARTMENT OF LABOR AND WORKFORCE DEVELOPMENT
PREVAILING WAGE RATE DETERMINATION**

County - UNION

day lost due to inclement weather. If Friday is not a make-up day, all hours on Friday shall be paid at time and one-half, inclusive of benefits.

RECOGNIZED HOLIDAYS: New Year's Day, Presidents' Day, Memorial Day, July 4th, Labor Day, Presidential Election Day, Veterans' Day, Thanksgiving Day, Christmas Day. Sunday holidays will be observed the following Monday.

**NEW JERSEY DEPARTMENT OF LABOR AND WORKFORCE DEVELOPMENT
PREVAILING WAGE RATE DETERMINATION**

County - UNION

Craft: Roofer PREVAILING WAGE RATE

	06/07/18
Foreman	W39.52 B26.28 T65.80
Journeyman	W37.52 B26.28 T63.80

Craft: Roofer APPRENTICE RATE SCHEDULE

INTERVAL	PERIOD AND RATES									
6 Months	15.00	18.76	22.51	26.26	30.01	33.77				
Benefits	0.00	0.00	21.40	21.40	21.40	21.40				

Ratio of Apprentices to Journeymen - *

- * A) For roofing jobs that are of the 1 or single ply nature: 1:2 or fraction thereof
- B) For roofing jobs on new built up roofs: 1:3 or fraction thereof
- C) For roofing jobs that are of a tear-off nature: 1:2 or fraction thereof
- D) For roofing jobs {not requiring complete removal of existing systems, installation done over existing roof}: 1:3 or fraction thereof

Craft: Roofer COMMENTS/NOTES

APPRENTICE RATE SCHEDULE FOR THOSE APPRENTICES ENTERING PROGRAM AFTER 4-1-17:

INTERVAL	PERIOD AND RATES							
6 Months	15.00	18.76	22.51	24.38	26.26	28.14	30.01	33.77
Benefits	0.00	0.00	21.40	21.40	21.40	21.40	21.40	21.40

Pitch: +.50 per hour

Mop Man: +.30 per hour

The regular workday consists of 8 hours between 8:00 AM and 4:30 PM.

OVERTIME:

Hours in excess of 8 per day, or before or after the regular workday, Monday through Friday, and all hours on Saturdays, Sundays, and holidays shall be paid at time and one-half the regular rate.

RECOGNIZED HOLIDAYS: New Year's Day, Good Friday, Memorial Day, July 4th, Labor Day, Presidential Election Day, Veterans' Day, Thanksgiving Day, Christmas Day.

**NEW JERSEY DEPARTMENT OF LABOR AND WORKFORCE DEVELOPMENT
PREVAILING WAGE RATE DETERMINATION**

County - UNION

Craft: Sheet Metal Sign Installation

PREVAILING WAGE RATE

	04/01/18
Foreman	W35.79 B33.00 T68.79
Journeyman	W34.54 B33.00 T67.54

Craft: Sheet Metal Sign Installation

APPRENTICE RATE SCHEDULE

INTERVAL	PERIOD AND RATES									
1000 hours	35%	40%	45%	50%	55%	60%	65%	70%	75%	80%
Benefits	11.17	12.73	14.30	15.86	17.82	19.43	21.03	22.63	24.23	25.82

Ratio of Apprentices to Journeymen - 1:3

Craft: Sheet Metal Sign Installation

COMMENTS/NOTES

FOREMAN REQUIREMENT:

When there are 6 or more Sheet Metal Sign Installers on a job, 1 shall be designated a Foreman.

The regular workday consists of 8 hours, between 7:00 AM and 3:30 PM.

OVERTIME:

Hours before or after the regular workday, Monday through Friday, and all hours worked on Saturday shall be paid at time and one-half the hourly rate. All hours on Sunday and holidays shall be paid at double the hourly rate.

Four(4) 10 hour days may be worked, Monday through Friday, at straight time, for projects lasting at least one week in duration. The fifth day may be used as a make-up day at straight time for a day lost due to inclement weather. However, if the fifth day is not a make-up day, all hours worked will be paid at time and one-half the hourly rate.

RECOGNIZED HOLIDAYS: New Year's Day, Presidents' Day, Good Friday, Memorial Day, July 4th, Labor Day, Veterans' Day, Thanksgiving Day and the day after, Christmas Day. Saturday holidays observed the preceding Friday, Sunday holidays observed the following Monday.

**NEW JERSEY DEPARTMENT OF LABOR AND WORKFORCE DEVELOPMENT
PREVAILING WAGE RATE DETERMINATION**

County - UNION

Craft: Sheet Metal Worker

PREVAILING WAGE RATE

	10/17/18	06/01/19	06/01/20
Foreman	W51.29	W0.00	W0.00
	B42.93	B0.00	B0.00
	T94.22	T97.22	T100.47
General Foreman	W52.29	W0.00	W0.00
	B42.93	B0.00	B0.00
	T95.22	T98.22	T101.47
Journeyman	W47.79	W0.00	W0.00
	B42.93	B0.00	B0.00
	T90.72	T93.72	T96.97

Craft: Sheet Metal Worker

APPRENTICE RATE SCHEDULE

INTERVAL	PERIOD AND RATES									
	Yearly	35%	45%	55%	65%	of	Journey	man	Wage	Rate
Benefit	35%	45%	55%	65%	of	Journey	man	Benefit	Rate	

Ratio of Apprentices to Journeymen - 1:4

Craft: Sheet Metal Worker

COMMENTS/NOTES

FOREMAN REQUIREMENTS:

- When there are 2 or more Sheet Metal Workers on a project, 1 must be designated a Foreman.
- When there are 17 or more Sheet Metal Workers on a project, 1 must be designated a General Foreman.
- When there is only 1 Sheet Metal Worker (1 Journeyman) on a project, he/she shall receive \$1.00 more than the regular Journeyman's rate.

The regular workday is 8 hours between 7:00 AM and 4:30 PM.

SHIFT DIFFERENTIAL:

- 2nd Shift (3:30 PM - 12:00 AM) : +17% of regular hourly rate
- Shift work must run for a minimum of 5 consecutive workdays.

OVERTIME:

- Hours in excess of 8 per day, or before or after the regular workday, that are not shift work, and the first 10 hours on Saturdays shall be paid at time and one-half of the regular rate, inclusive of benefits. Hours in excess of 10 per day on Saturday, and all hours on Sundays and holidays shall be at double the regular rate, inclusive of benefits.
- Four 10-hour days may be worked, Monday through Friday, at straight time, with hours in excess of 10 per day, and hours in excess of 40 per week paid at the overtime rates listed above.

RECOGNIZED HOLIDAYS: New Year's Day, Presidents' Day, Good Friday, Memorial Day, July 4th, Labor Day, Presidential Election Day, Veterans' Day, Thanksgiving Day, Christmas Day. Sunday holidays will be observed the following Monday.

**NEW JERSEY DEPARTMENT OF LABOR AND WORKFORCE DEVELOPMENT
PREVAILING WAGE RATE DETERMINATION**

County - UNION

Craft: Sprinkler Fitter

PREVAILING WAGE RATE

	01/01/19
Foreman	W64.33 B28.97 T93.30
General Foreman	W67.45 B28.97 T96.42
Journeyman	W60.23 B28.97 T89.20

Craft: Sprinkler Fitter

APPRENTICE RATE SCHEDULE

INTERVAL	PERIOD AND RATES									
	10.50	12.25	50%	55%	60%	65%	70%	75%	80%	85%
1000 Hours	10.50	12.25	50%	55%	60%	65%	70%	75%	80%	85%
Benefits	11.87	11.87	23.72	23.72	23.72	23.72	Intervals	7 to 10	Jourymn	Ben.

APPRENTICE RATE SCHEDULE FOR THOSE APPRENTICES REGISTERED AS OF 7-1-13:

INTERVAL	PERIOD AND RATES									
1000 hours	25%	30%	40%	45%	55%	60%	70%	75%	85%	90%
Benefits	11.87	11.87	23.72	23.72	23.72	23.72	Intervals	7 to 10	receive	Journeyman Ben.

Craft: Sprinkler Fitter

COMMENTS/NOTES

The regular workday consists of 8 consecutive hours between 6:00 AM and 4:30 PM.

FOREMAN REQUIREMENTS:

- The first Sprinkler Fitter on the job must be designated a Foreman.
- On any job having 12 or more Sprinkler Fitters, one must be designated a General Foreman.

SHIFT DIFFERENTIALS:

- Shift work must run for a minimum of 2 consecutive workdays.
- 2nd and 3rd shift shall receive an additional 15% of the regular rate, per hour.
- Any "off hours" shift starting at 8:00 PM or later shall receive an additional 25% of the regular rate, per hour.

OVERTIME:

The first 2 hours in excess of 8 per day, after the regular workday that are not shift work, Monday through Friday, shall be paid at time and one-half the regular rate. Hours worked in excess of 10 per day, Monday through Friday, and all hours on Saturday, Sunday and holidays, shall be paid double the regular rate.

Four 10 hour days may be worked, Monday through Friday, at straight-time.

RECOGNIZED HOLIDAYS: New Year's Day, Presidents' Day, Good Friday, Memorial Day, July 4th, Labor Day, Presidential Election Day, Veterans Day, Thanksgiving Day, Christmas Day.

**NEW JERSEY DEPARTMENT OF LABOR AND WORKFORCE DEVELOPMENT
PREVAILING WAGE RATE DETERMINATION**

County - UNION

Craft: Tile Finisher-Marble

PREVAILING WAGE RATE

	01/01/19
Finisher	W47.07 B34.58 T81.65

Craft: Tile Finisher-Marble

APPRENTICE RATE SCHEDULE

INTERVAL	PERIOD AND RATES									
750 Hours	40%	45%	50%	55%	60%	65%	70%	75%	85%	95%

Ratio of Apprentices to Journeymen - 1:4

Craft: Tile Finisher-Marble

COMMENTS/NOTES

OVERTIME:

Hours in excess of 7 per day, Monday through Friday, and the first 7 hours on Saturdays shall be paid at time and one half the regular rate, inclusive of benefits. Hours in excess of 7 on Saturdays and all hours on Sundays and holidays shall be paid at double the regular rate, inclusive of benefits.

RECOGNIZED HOLIDAYS: New Year's Day, Presidents' Day, Good Friday, Memorial Day, July 4th, Labor Day, Columbus Day, Veterans' Day, Thanksgiving Day and the day after, Christmas Day. Sunday holidays observed the following Monday.

**NEW JERSEY DEPARTMENT OF LABOR AND WORKFORCE DEVELOPMENT
PREVAILING WAGE RATE DETERMINATION**

County - UNION

Craft: Tile Setter - Ceramic

PREVAILING WAGE RATE

	12/03/18
Finisher	W45.08 B30.27 T75.35
Setter	W58.37 B33.69 T92.06

Craft: Tile Setter - Ceramic

APPRENTICE RATE SCHEDULE

INTERVAL	PERIOD AND RATES									
750 Hours	35%	40%	50%	55%	60%	65%	70%	75%	80%	90%

Ratio of Apprentices to Journeymen - 1:4

Craft: Tile Setter - Ceramic

COMMENTS/NOTES

OVERTIME:

Hours in excess of 7 per day, and the first 10 hours on Saturdays shall be paid at time and one-half the hourly rate. All hours on Saturdays after 10 hours shall be paid double the hourly rate. All hours on Sundays and holidays shall be paid at double the hourly rate.

RECOGNIZED HOLIDAYS: New Year's Day, Memorial Day, July 4th, Labor Day, Thanksgiving Day, Christmas Day.

**NEW JERSEY DEPARTMENT OF LABOR AND WORKFORCE DEVELOPMENT
PREVAILING WAGE RATE DETERMINATION**

County - UNION

Craft: Tile Setter - Marble

PREVAILING WAGE RATE

	01/01/19
Tile Setter	W59.03 B36.82 T95.85

Craft: Tile Setter - Marble

APPRENTICE RATE SCHEDULE

INTERVAL	PERIOD AND RATES									
750 Hours	40%	45%	50%	55%	60%	65%	70%	75%	85%	95%

Ratio of Apprentices to Journeymen - 1:4

Craft: Tile Setter - Marble

COMMENTS/NOTES

OVERTIME:

Hours in excess of 7 per day, Monday through Friday, and the first 7 hours on Saturdays shall be paid at time and one-half the regular rate, inclusive of benefits. Hours in excess of 7 on Saturdays, and all hours on Sundays and holidays shall be paid at double the regular rate, inclusive of benefits.

RECOGNIZED HOLIDAYS: New Year's Day, Presidents' Day, Good Friday, Memorial Day, July 4th, Labor Day, Columbus Day, Veterans' Day, Thanksgiving Day and the day after, Christmas Day. Sunday holidays observed the following Monday.

**NEW JERSEY DEPARTMENT OF LABOR AND WORKFORCE DEVELOPMENT
PREVAILING WAGE RATE DETERMINATION**

County - UNION

Craft: Tile Setter - Mosaic & Terrazzo

PREVAILING WAGE RATE

	01/01/19
Grinder or Assistant	W54.24 B36.03 T90.27
Mechanic	W55.84 B36.05 T91.89
Terrazzo Resinous Worker	W46.57 B29.20 T75.77

Craft: Tile Setter - Mosaic & Terrazzo

APPRENTICE RATE SCHEDULE

INTERVAL	PERIOD AND RATES									
750 Hours	50%	55%	60%	65%	70%	75%	85%	95%	100%	

Ratio of Apprentices to Journeymen - 1:5

Craft: Tile Setter - Mosaic & Terrazzo

COMMENTS/NOTES

APPRENTICE RATE SCHEDULE FOR THOSE APPRENTICES ENTERING PROGRAM AFTER 7-1-17:

INTERVAL	PERIOD AND RATES						
1500 Hours	35%	45%	60%	70%	80%	90%	100%

The regular workday consists of 7 hours, between 8:00 AM and 3:30 PM.

OVERTIME:

- Hours in excess of 7 per day, or before or after the regular workday, Monday through Friday, and all hours on Saturdays shall be paid at time and one-half the hourly rate. All hours on Sundays and holidays shall be paid at double the hourly rate.

RECOGNIZED HOLIDAYS: New Year's Day, Presidents' Day, Good Friday, Monday after Easter, Memorial Day, July 4th, Labor Day, Columbus Day, Veterans' Day, Thanksgiving Day and the day after, Christmas Day. Sunday holidays observed the following Monday.

**NEW JERSEY DEPARTMENT OF LABOR AND WORKFORCE DEVELOPMENT
PREVAILING WAGE RATE DETERMINATION**

County - UNION

Craft: Truck Driver

PREVAILING WAGE RATE

	11/01/18
Bucket, Utility, Pick-up, Fuel Delivery trucks	W37.66 B35.80 T73.46
Dump truck, Asphalt Distributor, Tack Spreader	W37.66 B35.80 T73.46
Euclid-type vehicles (large, off-road equipment)	W37.81 B35.80 T73.61
Helper on Asphalt Distributor truck	W37.66 B35.80 T73.46
Slurry Seal, Seeding/Fertilizing/ Mulching truck	W37.66 B35.80 T73.46
Straight 3-axle truck	W37.71 B35.80 T73.51
Tractor Trailer (all types)	W37.81 B35.80 T73.61
Vacuum or Vac-All truck (entire unit)	W37.66 B35.80 T73.46
Winch Trailer	W37.91 B35.80 T73.71

Craft: Truck Driver

COMMENTS/NOTES

BLENDED RATE:

When a truck driver is performing work on the site and also serving as a material delivery driver, the driver shall be paid a "blended rate" which shall be 80% of the above-listed wage rates, plus the full benefit rate. This rate shall be used when the driver "round robins" for a minimum of 6 hours during the work day.

HAZARDOUS WASTE REMOVAL:

- On hazardous waste removal work on a State designated hazardous waste site where the driver is in direct contact with hazardous materials and when personal protective equipment is required for respiratory, skin, and eye protection, the driver shall receive an additional \$3.00 per hour (with or without protective gear).
- A hazardous waste related certified worker at a designated hazardous waste site who is not working in a zone requiring level A, B or C personal protection shall receive an additional \$1.00 per hour.

TRUCK FOREMAN: \$.75 cents per hour above regular rate. Overtime shall be increased accordingly.

**NEW JERSEY DEPARTMENT OF LABOR AND WORKFORCE DEVELOPMENT
PREVAILING WAGE RATE DETERMINATION**

County - UNION

The regular workday shall be 8 hours, starting between 6:00 AM and 8:00 AM.

SHIFT DIFFERENTIAL:

- Shifts starting at 4:00 PM (2nd Shift): + \$2.50 per hour.
- Shifts starting at 12:00 AM (midnight/3rd Shift): time and one-half the hourly rate.
- Shifts starting at a time other than from 6:00 AM to 8:00 AM, when such hours are mandated by the project owner: + \$2.50 per hour.

OVERTIME:

- Hours in excess of 8 per day, or before or after the regular workday, Monday through Friday, that are not shift work, and all hours on Saturdays shall be paid at time and one-half the hourly rate. All hours on Sundays and holidays shall be paid at double the hourly rate.
- Employees may work four 10-hour days at straight time, Monday through Thursday, with Friday used as a make-up day for a lost day. If Friday is not a make-up day, then all hours on Friday shall be paid at time and one-half the hourly rate.

RECOGNIZED HOLIDAYS: New Year's Day, Presidents' Day, Memorial Day (Decoration Day), July 4th, Labor Day, Presidential Election Day, Veterans' Day, Thanksgiving Day, Christmas Day. Sunday holidays will be observed the following Monday. The day after Thanksgiving may be substituted for Veterans' Day.

**NEW JERSEY DEPARTMENT OF LABOR AND WORKFORCE DEVELOPMENT
PREVAILING WAGE RATE DETERMINATION**

County - UNION

Craft: Truck Driver-Material Delivery Driver

PREVAILING WAGE RATE

	08/24/18	04/01/19	04/01/20
Driver	W24.60	W25.10	W25.60
	B14.81	B15.25	B15.71
	T39.41	T40.35	T41.31

Craft: Truck Driver-Material Delivery Driver

COMMENTS/NOTES

BLENDED RATE:

When a truck driver is performing work on the site and also serving as a material delivery driver, the driver shall be paid a "blended rate". See the "Truck Driver" craft for the blended rates.

Truck Foreman/Shop Steward: +\$0.25 per hour

SHIFT DIFFERENTIALS:

- 2nd Shift shall receive an additional \$0.50 per hour
- 3rd Shift shall receive time and one-half the hourly rate.

OVERTIME:

- Hours in excess of 8 per day, or before or after the regular workday that are not shift work, Monday through Friday, and all hours on Saturday shall be paid at time and one-half the hourly rate. All hours on Sunday and holidays shall be paid at double the hourly rate.

RECOGNIZED HOLIDAYS: New Year's Day, President's Day, Memorial Day (Decoration Day), July 4th, Labor Day, Presidential Election Day, Veterans' Day, Thanksgiving Day, Christmas Day. Sunday holidays will be observed the following Monday. The day after Thanksgiving may be substituted for Veterans' Day.

**NEW JERSEY DEPARTMENT OF LABOR AND WORKFORCE DEVELOPMENT
PREVAILING WAGE RATE DETERMINATION**

County - UNION

Craft: Welder

PREVAILING WAGE RATE

Welder

Craft: Welder

COMMENTS/NOTES

Welders rate is the same as the craft to which the welding is incidental .

STATEWIDE RATES

OPERATING ENGINEERS **Rates Expiration Date :**

{For apprentice rates refer to "Operating Engineers" apprentice rates in any county rate package}

The regular workday consists of 8 hours, Monday to Friday, between 6:00 AM and 4:30 PM.

SHIFT DIFFERENTIALS:

- Shift work must run for 5 consecutive workdays.
- When 2 shifts are worked, the second shift shall receive an additional 10% of the regular rate inclusive of benefits, per hour.
- When 3 shifts are worked, the second shift shall receive 8 hours pay for 7.5 hours of work, plus an additional 10% of the regular rate inclusive of benefits, per hour. The third shift shall receive 8 hours pay for 7 hours of work, plus an additional 15% of the regular rate inclusive of benefits, per hour.
- When such hours are mandated by the project owner, a shift that starts between 8:00 PM and midnight and ends by 6:00 AM Saturday, or that starts after 8:00 PM on Sunday, provided there are consecutive hours of work within the shift, shall receive an additional 15% of the regular rate, inclusive of benefits.
- On Highway, Road, Street, and Sewer projects irregular shifts starting between 5:00 PM and 12:00 AM may be worked Monday through Friday, and shall receive an additional 15% of the regular rate, inclusive of benefits. When working with other trades that receive a higher irregular shift rate, the Operating Engineer shall also receive the higher irregular shift rate.

OVERTIME:

- Hours in excess of 8 per day, or outside of the regular workday, Monday through Friday, that are not shift work, and all hours on Saturdays shall be paid at time and one-half the regular rate, inclusive of benefits. All hours on Sundays and holidays shall be paid at double the regular rate, inclusive of benefits.
- Four 10-hour days may be worked, Monday through Thursday, at straight time, with all hours on Friday paid at time and one-half the regular rate, inclusive of benefits.

RECOGNIZED HOLIDAYS: New Year's Day, Presidents' Day, Memorial Day, July 4th, Labor Day, Presidential Election Day, Veterans Day, Thanksgiving Day, Christmas Day. Sunday holidays observed the following Monday. When all trades on a particular job site agree, the day after Thanksgiving may be substituted for Veteran's Day.

On hazardous waste removal work or asbestos removal work, on a state or federally designated hazardous waste site, where the operating engineer is in direct contact with hazardous material and when personal protective equipment is required for respiratory, skin, and eye protection, the operating engineer shall receive an additional 20% of the hourly wage, per hour.

OPERATING ENGINEERS **Rates Expiration Date :**

Effective Dates:

01/01/2019			07/01/2019
Rate	Fringe	Total	Total
50.18	32.85	83.03	85.38

CLASSIFICATIONS:

A-Frame

Backhoe (combination)

Boom Attachment on loaders (Except pipehook)

Boring & Drilling Machine

Brush Chopper, Brush Shredder, Tree Shredder, Tree Shearer

Bulldozer, finish grade

Cableway

Carryall

Concrete Pump

Concrete Pumping System (Pumpcrete & similar types)

Conveyor, 125 feet or longer

Drill Doctor (Duties include dust collector and maintenance)

Front End Loader (2 cu. yds. but less than 5 cu. yds.)

Grader, finish

Groove Cutting Machine (ride-on type)

Heater Planer

Hoist: Outside Material Tower Hoist (all types including steam, gas, diesel, electric, air hydraulic, single and double drum, concrete, brick shaft caisson, snorkle roof, and other similar types, Except Chicago-boom type) * receives an additional \$1.00 per hour on 100 ft. up to 199 ft. total height, and an additional \$2.00 per hour on 200 ft. and over total height.

Hydraulic Crane (10 tons & under)

Hydraulic Dredge

Hydro-Axe

Hydro-Blaster

OPERATING ENGINEERS **Rates Expiration Date :**

Effective Dates:

	01/01/2019		07/01/2019
Rate	Fringe	Total	Total
50.18	32.85	83.03	85.38

CLASSIFICATIONS:

Jack (screw, air hydraulic, power-operated unit, or console type, Except hand jack or pile load test type)

Log Skidder

Pan

Paver, concrete

Plate & Frame Filter Press

Pumpcrete (unit type)

Pumpcrete, Squeezecrete, or Concrete Pumping machine (regardless of size)

Scraper

Side Boom

Straddle Carrier (Ross and similar types)

Whiphammer

Winch Truck (hoisting)

OPERATING ENGINEERS **Rates Expiration Date :**

Effective Dates:

01/01/2019		07/01/2019	
Rate	Fringe	Total	Total
48.27	32.85	81.12	83.47

CLASSIFICATIONS:

- Asphalt Curbing Machine
- Asphalt Plant Engineer
- Asphalt Spreader
- Autograde Curb Trimmer & Sidewalk Shoulder Slipform (CMI & similar types)
- Autograde Curecrete Machine (CMI & similar types)
- Autograde Tube Finisher & Texturing Machine (CMI & similar types)
- Bar Bending Machines (Power)
- Batcher, Batching Plant, & Crusher [On Site]
- Belt Conveyor System
- Boom-Type Skimmer Machine
- Bridge Deck Finisher
- Bulldozer (all sizes)
- Captain (Power Boats)
- Car Dumper (railroad)
- Compressor & Blower unit for loading/unloading of concrete, cement, fly ash, or similar type materials (used independently or truck-mounted)
- Compressor (2 or 3 battery)
- Concrete Breaking Machine
- Concrete Cleaning/Decontamination Machine
- Concrete Finishing Machine
- Concrete Saw or Cutter (ride-on type)
- Concrete Spreader (Hetzl, Rexomatic & similar types)
- Concrete Vibrator

OPERATING ENGINEERS **Rates Expiration Date :**

Effective Dates:

01/01/2019		07/01/2019	
Rate	Fringe	Total	Total
48.27	32.85	81.12	83.47

CLASSIFICATIONS:

- Conveyors - under 125 feet
- Crane Signalman
- Crushing Machine
- Directional Boring Machine
- Ditching Machine - Small (Ditchwitch, Vermeer or similar types)
- Dope Pot - Mechanical (with or without pump)
- Dumpster
- Elevator
- Fireman
- Fork Lift (Economobile, Lull & similar types)
- Front End Loader (1 cu. yd. and over but less than 2 cu. yds.)
- Generator (2 or 3 battery)
- Giraffe Grinder
- Goldhofer/Hydraulic Jacking Trailer
- Grader & Motor Patrols
- Grout Pump
- Gunnite Machine (Excluding nozzle)
- Hammer - Vibratory (in conjunction with generator)
- Heavy Equipment Robotics - Operator/Technician
- Hoist (roof, tigger, aerial platform hoist, house car)
- Hopper
- Hopper Doors (power operated)
- Ladder (motorized)

OPERATING ENGINEERS **Rates Expiration Date :**

Effective Dates:

01/01/2019		07/01/2019	
Rate	Fringe	Total	Total
48.27	32.85	81.12	83.47

CLASSIFICATIONS:

Laddervator

Locomotive (Dinky-type)

Maintenance Utility Man

Master Environmental Maintenance Technician

Mechanic

Mixer (Except paving mixers)

Pavement Breaker (truck-mounted or small self-propelled
ride-on type)

Pavement Breaker - maintenance of compressor or hydraulic unit

Pipe Bending Machine (power)

Pitch Pump

Plaster Pump (regardless of size)

Post Hole Digger (post pounder, auger)

Rod Bending Machines

Roller (black top)

Scale (power)

Seamen Pulverizing Mixer

Shoulder Widener

Silo

Skimmer Machine (boom type)

Steel Cutting Machine (service & maintenance)

Tamrock Drill

Tractor

Transfer Machines

OPERATING ENGINEERS **Rates Expiration Date :**

Effective Dates:

01/01/2019			07/01/2019
Rate	Fringe	Total	Total
48.27	32.85	81.12	83.47

CLASSIFICATIONS:

Tug Captains

Tug Master (Power Boats)

Ultra High Pressure Waterjet Cutting Tool System -
Operator/Maintenance Technician

Vacuum Blasting Machine - Operator/Maintenance Technician

Vibrating Plant (used with unloading)

Welder & Repair Mechanic

Effective Dates:

01/01/2019			07/01/2019
Rate	Fringe	Total	Total
44.93	32.85	77.78	80.13

CLASSIFICATIONS:

Assistant Engineer/Oiler

Driller's Helper

Field Engineer - Transit man or Instrument man

Maintenance Apprentice (Deckhand)

Maintenance Apprentice (Oiler)

Mechanic's Helper

Off Road Back Dump

Tire Repair & Maintenance

Effective Dates:

01/01/2019			07/01/2019
Rate	Fringe	Total	Total
42.35	32.85	75.20	77.55

CLASSIFICATIONS:

Field Engineer - Rodman or Chainman

TERRITORY
ENTIRE STATE

NEW JERSEY DEPARTMENT OF LABOR AND WORKFORCE DEVELOPMENT
PREVAILING WAGE RATE DETERMINATION

OPERATING ENGINEERS Rates Expiration Date :

Effective Dates:

	01/01/2019		07/01/2019
Rate	Fringe	Total	Total
52.51	32.85	85.36	87.71

CLASSIFICATIONS:

Lead Engineer, Foreman Engineer, Safety Engineer (minimum)

OPERATING ENGINEERS **Rates Expiration Date :**

Effective Dates:

01/01/2019		07/01/2019	
Rate	Fringe	Total	Total
51.77	32.85	84.62	86.97

CLASSIFICATIONS:

Autograde Pavement Profiler (CMI & similar types)

Autograde Pavement Profiler - Recycle Type (CMI & similar types)

Autograde Placer/Trimmer/Spreader Combination (CMI & similar types)

Autograde Slipform Paver (CMI & similar types)

Backhoe (Excavator)

Central Power Plant

Concrete Paving Machine

Cranes, Derricks, Pile Drivers (all types), under 100 tons with a boom (including jib and/or leads) under 100 ft.

Draglines

Drill, Bauer, AMI and similar types

Drillmaster, Quarrymaster

Drillmaster/Quarrymaster (down-the-hole drill), rotary drill, self-propelled hydraulic drill, self-powered drill

Elevator Grader

Field Engineer-Chief of Party

Front End Loader (5 cu. yards or larger)

Gradall

Grader, Rago

Helicopter Co-Pilot

Helicopter Communications Engineer

Juntann Pile Driver

Locomotive (large)

Mucking Machine

OPERATING ENGINEERS **Rates Expiration Date :**

Effective Dates:

01/01/2019			07/01/2019
Rate	Fringe	Total	Total
51.77	32.85	84.62	86.97

CLASSIFICATIONS:

Pavement & Concrete Breaker (Superhammer & Hoe Ram)

Pile Driver

Prentice Truck

Roadway Surface Grinder

Scooper (loader & shovel)

Shovel (Excavator)

Trackhoe (Excavator)

Tree Chopper with boom

Trenching Machine (cable plow)

Tunnel Boring Machine

Vacuum Truck

OPERATING ENGINEERS **Rates Expiration Date :**

Effective Dates:

01/01/2019		07/01/2019	
Rate	Fringe	Total	Total
46.64	32.85	79.49	81.84

CLASSIFICATIONS:

- Chipper
- Compressor (single)
- Concrete Spreader (small type)
- Conveyor Loader (Except elevator graders)
- Engines, Large Diesel (1620 HP) & Staging Pump
- Farm Tractor
- Fertilizing Equipment (operation & maintenance)
- Fine Grade Machine (small type)
- Form Line Grader (small type)
- Front End Loader (under 1 cubic yard)
- Generator (single)
- Grease, Gas, Fuel, & Oil Supply Trucks
- Heaters (Nelson or other type)
- Lights - portable generating light plant
- Mixer, Concrete (small)
- Mulching Equipment (operation & maintenance)
- Power Broom or Sweeper
- Pump (diesel engine & hydraulic - regardless of power)
- Pump (larger than 2 inch suction, including submersible pumps)
- Road Finishing Machine (small type)
- Roller - grade, fill, or stone base
- Seeding Equipment (operation & maintenance)
- Sprinkler & Water Pump Trucks

OPERATING ENGINEERS **Rates Expiration Date :**

Effective Dates:

01/01/2019			07/01/2019
Rate	Fringe	Total	Total
46.64	32.85	79.49	81.84

CLASSIFICATIONS:

Steam Generator or Boiler

Stone Spreader

Tamping Machine (vibrating ride-on type)

Temporary Heating Plant (Nelson or other type, including propane, natural gas, and flow-type units)

Water or Sprinkler Truck

Welding Machine (gas, diesel, or electric convertor, of any type)

Welding System - Multiple (rectifier transformer type)

Wellpoint Systems (including installation by bull gang and maintenance)

Effective Dates:

01/01/2019			07/01/2019
Rate	Fringe	Total	Total
53.59	32.85	86.44	88.79

CLASSIFICATIONS:

Helicopter Pilot/Engineer

Effective Dates:

01/01/2019			07/01/2019
Rate	Fringe	Total	Total
58.27	32.85	91.12	93.47

CLASSIFICATIONS:

Cranes, Derricks, Pile Driver (all types), 100 tons and over and TOWER CRANE with boom (including jib and/or leads) 140 ft. and over

Effective Dates:

01/01/2019			07/01/2019
Rate	Fringe	Total	Total
57.27	32.85	90.12	92.47

CLASSIFICATIONS:

Cranes, Derricks, Pile Driver (all types), 100 tons and over and TOWER CRANE with boom (including jib and/or leads) from 100 ft. to 139 ft.

OPERATING ENGINEERS **Rates Expiration Date :**

Effective Dates:

01/01/2019			07/01/2019
Rate	Fringe	Total	Total
53.77	32.85	86.62	88.97

CLASSIFICATIONS:

Cranes, Derricks, Pile Driver (all types) , under 100 tons with a boom (including jib and/or leads) 140 ft. and over

Effective Dates:

01/01/2019			07/01/2019
Rate	Fringe	Total	Total
56.27	32.85	89.12	91.47

CLASSIFICATIONS:

Cranes, Derricks, Pile Driver (all types), 100 tons and over and TOWER CRANE with a boom (including jib and/or leads) under 100 ft.

Effective Dates:

01/01/2019			07/01/2019
Rate	Fringe	Total	Total
52.77	32.85	85.62	87.97

CLASSIFICATIONS:

Cranes, Derricks, Pile Driver (all types), under 100 tons with a boom (including jib and/or leads) from 100 ft. to 139 ft.

STRUCTURAL STEEL ERECTION **Rates Expiration Date :**

{For apprentice rates refer to "Operating Engineers" apprentice rates in any county rate package}

The regular workday consists of 8 hours, Monday to Friday, between 6:00 AM and 4:30 PM.

SHIFT DIFFERENTIALS:

- Shift work must run for 5 consecutive workdays.
- When 2 shifts are worked, the second shift shall receive an additional 10% of the regular rate inclusive of benefits, per hour.
- When 3 shifts are worked, the second shift shall receive 8 hours pay for 7.5 hours of work, plus an additional 10% of the regular rate inclusive of benefits, per hour. The third shift shall receive 8 hours pay for 7 hours of work, plus an additional 15% of the regular rate inclusive of benefits, per hour.
- When such hours are mandated by the project owner, a shift that starts between 8:00 PM and midnight and ends by 6:00 AM Saturday, or that starts after 8:00 PM on Sunday, provided there are consecutive hours of work within the shift, shall receive an additional 15% of the regular rate, inclusive of benefits.
- On Highway, Road, Street, and Sewer projects irregular shifts starting between 5:00 PM and 12:00 AM may be worked Monday through Friday, and shall receive an additional 15% of the regular rate, inclusive of benefits. When working with other trades that receive a higher irregular shift rate, the Operating Engineer shall also receive the higher irregular shift rate.

OVERTIME:

- Hours in excess of 8 per day, or outside of the regular workday, Monday through Friday, that are not shift work, and all hours on Saturdays shall be paid at time and one-half the regular rate, inclusive of benefits. All hours on Sundays and holidays shall be paid at double the regular rate, inclusive of benefits.
- Four 10-hour days may be worked, Monday through Thursday, at straight time, with all hours on Friday paid at time and one-half the regular rate, inclusive of benefits.

RECOGNIZED HOLIDAYS: New Year's Day, Presidents' Day, Memorial Day, July 4th, Labor Day, Presidential Election Day, Veterans Day, Thanksgiving Day, Christmas Day. Sunday holidays observed the following Monday. When all trades on a particular job site agree, the day after Thanksgiving may be substituted for Veteran's Day.

On hazardous waste removal work or asbestos removal work, on a state or federally designated hazardous waste site, where the operating engineer is in direct contact with hazardous material and when personal protective equipment is required for respiratory, skin, and eye protection, the operating engineer shall receive an additional 20% of the hourly wage, per hour.

Effective Dates:

	01/01/2019		07/01/2019
Rate	Fringe	Total	Total
55.40	32.85	88.25	90.60

CLASSIFICATIONS:

Helicopter Co-Pilot & Communications Engineer

TERRITORY
ENTIRE STATE

NEW JERSEY DEPARTMENT OF LABOR AND WORKFORCE DEVELOPMENT
PREVAILING WAGE RATE DETERMINATION

STRUCTURAL STEEL ERECTION Rates Expiration Date :

Effective Dates:

01/01/2019			07/01/2019
Rate	Fringe	Total	Total
51.34	32.85	84.19	86.54

CLASSIFICATIONS:

A-Frame

Cherry Picker -10 tons or less (Over 10 tons use crane rate)

Hoist (all types Except Chicago-boom)

Jack (screw, air hydraulic, power-operated unit or console type, Except hand jack or pile load test type)

Side Boom

Straddle Carrier

STRUCTURAL STEEL ERECTION **Rates Expiration Date :**

Effective Dates:

01/01/2019			07/01/2019
Rate	Fringe	Total	Total
48.68	32.85	81.53	83.88

CLASSIFICATIONS:

- Aerial Platform Used On Hoists
- Apprentice Engineer/Oiler with Compressor or Welding Machine
- Captain (Power Boats)
- Compressor (2 or 3 in battery)
- Concrete Cleaning/Decontamination Machine Operator
- Conveyor or Tugger Hoist
- Directional Boring Machine
- Elevator or House Car
- Fireman
- Forklift
- Generator (2 or 3)
- Heavy Equipment Robotics, Operator/Technician
- Maintenance Utility Man
- Master Environmental Maintenance Technician
- Tug Master (Power Boats)
- Ultra High Pressure Waterjet Cutting Tool System Operator/Maintenance Technician
- Vacuum Blasting Machine Operator/Maintenance Technician
- Welding Machines, Gas or Electric Converters on any type-2 or 3 in battery including diesels

STRUCTURAL STEEL ERECTION **Rates Expiration Date :**

Effective Dates:

01/01/2019			07/01/2019
Rate	Fringe	Total	Total
47.15	32.85	80.00	82.35

CLASSIFICATIONS:

Compressor (Single)

Generators

Welding Machines, Gas, Diesel, Or Electric Converters of any type-single

Welding System, Multiple (Rectifier Transformer Type)

Effective Dates:

01/01/2019			07/01/2019
Rate	Fringe	Total	Total
45.39	32.85	78.24	80.59

CLASSIFICATIONS:

Assistant Engineer/Oiler

Drillers Helper

Field Engineer - Transit/Instrument Man

Maintenance Apprentice (Deckhand)

Maintenance Apprentice (Oiler)

Off Road Back Dump

Effective Dates:

01/01/2019			07/01/2019
Rate	Fringe	Total	Total
52.96	32.85	85.81	88.16

CLASSIFICATIONS:

Lead Engineer, Foreman Engineer, Safety Engineer (Minimum)

Effective Dates:

01/01/2019			07/01/2019
Rate	Fringe	Total	Total
42.35	32.85	75.20	77.55

CLASSIFICATIONS:

Field Engineer - Rodman or Chainman

STRUCTURAL STEEL ERECTION **Rates Expiration Date :**

Effective Dates:

01/01/2019			07/01/2019
Rate	Fringe	Total	Total
52.10	32.85	84.95	87.30

CLASSIFICATIONS:

Field Engineer-Chief of Party

Vacuum Truck

Effective Dates:

01/01/2019			07/01/2019
Rate	Fringe	Total	Total
60.29	32.85	93.14	95.49

CLASSIFICATIONS:

Cranes (all cranes, land or floating with booms, including jib, 140 ft. and over, above ground). Derricks (all derricks, land, floating or Chicago Boom type with booms including jib, 140 ft. and over, above ground), and Pile Drivers (all types) 100 tons and over and Tower Cranes.

Effective Dates:

01/01/2019			07/01/2019
Rate	Fringe	Total	Total
58.63	32.85	91.48	93.83

CLASSIFICATIONS:

Cranes (all cranes, land or floating with booms including jib, less than 140 ft. above ground), Derricks (all derricks, land, floating or Chicago Boom type with booms including jib, less than 140 ft. above ground), Pile Drivers (all types), 100 tons and over and Tower Crane.

Effective Dates:

01/01/2019			07/01/2019
Rate	Fringe	Total	Total
55.79	32.85	88.64	90.99

CLASSIFICATIONS:

Cranes (all cranes, land or floating with booms including jib, 140 ft. and over, above ground), Derricks (all derricks, land, floating or Chicago Boom type with booms including jib, 140 ft. and over, above ground), Pile Drivers (all types), under 100 tons.

Effective Dates:

01/01/2019			07/01/2019
Rate	Fringe	Total	Total
54.13	32.85	86.98	89.33

CLASSIFICATIONS:

Cranes (all cranes, land or floating with booms including jib, less than 140 ft. above ground), Derricks (all derricks, land, floating or Chicago Boom type with booms including jib, less than 140 ft. above ground), Pile Drivers (all types), under 100 tons.

TERRITORY
ENTIRE STATE

NEW JERSEY DEPARTMENT OF LABOR AND WORKFORCE DEVELOPMENT
PREVAILING WAGE RATE DETERMINATION

STRUCTURAL STEEL ERECTION Rates Expiration Date :

Effective Dates:

01/01/2019			07/01/2019
Rate	Fringe	Total	Total
55.79	32.85	88.64	90.99

CLASSIFICATIONS:

Helicopter Pilot & Engineer

TEST BORING PRELIMINARY TO CONSTRUCTION-SOUTH/WEST **Rates Expiration Date :**

THESE RATES APPLY IN THE FOLLOWING COUNTIES ONLY:

Atlantic, Burlington, Camden, Cape May, Cumberland, Gloucester, Hunterdon, Mercer, Monmouth, Ocean, Salem, Sussex, Warren

The regular workday consists of 8 hours, Monday to Friday, between 6:00 AM and 4:30 PM.

SHIFT DIFFERENTIALS:

- Shift work must run for 5 consecutive workdays.
- When 2 shifts are worked, the second shift shall receive an additional 10% of the regular rate inclusive of benefits, per hour.
- When 3 shifts are worked, the second shift shall receive 8 hours pay for 7.5 hours of work, plus an additional 10% of the regular rate inclusive of benefits, per hour. The third shift shall receive 8 hours pay for 7 hours of work, plus an additional 15% of the regular rate inclusive of benefits, per hour.
- When such hours are mandated by the project owner, a shift that starts between 8:00 PM and midnight and ends by 6:00 AM Saturday, or that starts after 8:00 PM on Sunday, provided there are consecutive hours of work within the shift, shall receive an additional 15% of the regular rate, inclusive of benefits.
- On Highway, Road, Street, and Sewer projects irregular shifts starting between 5:00 PM and 12:00 AM may be worked Monday through Friday, and shall receive an additional 15% of the regular rate, inclusive of benefits. When working with other trades that receive a higher irregular shift rate, the Operating Engineer shall also receive the higher irregular shift rate.

OVERTIME:

- Hours in excess of 8 per day, or outside of the regular workday, Monday through Friday, that are not shift work, and all hours on Saturdays shall be paid at time and one-half the regular rate, inclusive of benefits. All hours on Sundays and holidays shall be paid at double the regular rate, inclusive of benefits.
- Four 10-hour days may be worked, Monday through Thursday, at straight time, with all hours on Friday paid at time and one-half the regular rate, inclusive of benefits.

RECOGNIZED HOLIDAYS: New Year's Day, Presidents' Day, Memorial Day, July 4th, Labor Day, Presidential Election Day, Veterans Day, Thanksgiving Day, Christmas Day. Sunday holidays observed the following Monday. When all trades on a particular job site agree, the day after Thanksgiving may be substituted for Veteran's Day.

On hazardous waste removal work or asbestos removal work, on a state or federally designated hazardous waste site, where the operating engineer is in direct contact with hazardous material and when personal protective equipment is required for respiratory, skin, and eye protection, the operating engineer shall receive an additional 20% of the hourly wage, per hour.

Effective Dates:

	01/01/2019		07/01/2019
Rate	Fringe	Total	Total
51.77	32.85	84.62	86.97

CLASSIFICATIONS:

Driller

Effective Dates:

	01/01/2019		07/01/2019
Rate	Fringe	Total	Total
44.93	32.85	77.78	80.13

CLASSIFICATIONS:

Driller's Helper

FREE AIR TUNNEL JOBS **Rates Expiration Date :**

{For apprentice rates refer to "Heavy & General" apprentice rates in any county rate package}

The regular workday consists of 8 hours, starting at 7:00 AM or 8:00 AM.

SHIFT DIFFERENTIALS:

- Shifts must start at 3:00 PM, 4:00 PM, 12:00 AM, or 1:00 AM, to be considered shift work, except when the project owner mandates special hours of work in the job specifications, in which case those hours may be considered shift work.
- When such hours are mandated by the project owner, a shift that begins before midnight on Friday and ends on Saturday morning, or that begins at or after 8:00 PM on Sunday and ends on Monday morning may be paid at the shift differential rate.
- Shifts shall receive an additional \$3.00 per hour.

OVERTIME:

- Hours in excess of 8 per day, Monday through Friday, or outside of the regular workday that are not shift work, and all hours on Saturdays, shall be paid at time and one-half the hourly rate. All hours on Sundays and holidays shall be paid at double the hourly rate.
- Four 10-hour days may be worked, Monday through Thursday, at straight time, with Friday used as a make-up day for a day lost to inclement weather. If Friday is not a make-up day, all hours on Friday shall be paid at time and one-half the hourly rate.

RECOGNIZED HOLIDAYS: New Year's Day, Presidents' Day, Memorial Day, July 4th, Labor Day, Presidential Election Day, Veterans' Day, Thanksgiving Day, Christmas Day. Sunday holidays observed the following Monday. Veterans Day may be substituted for the day after Thanksgiving. However, in the trading of Veterans Day for the day after Thanksgiving, if overtime is worked on Veterans Day, it shall be paid at double the hourly rate.

Hazardous Waste Work:

- where Level A, B, or C protection is required: + \$3.00/hr
- other Hazardous Waste site: + \$1.00/hr

Effective Dates:

	09/01/2018		03/01/2019	03/01/2020
Rate	Fringe	Total	Total	Total
42.75	30.28	73.03	75.78	78.28

CLASSIFICATIONS:

Walking Boss & Superintendent

Effective Dates:

	09/01/2018		03/01/2019	03/01/2020
Rate	Fringe	Total	Total	Total
42.45	30.28	72.73	75.48	77.98

CLASSIFICATIONS:

Heading Foreman, Shaft Foreman, Rod Foreman, Electrician Foreman, Rigging Foreman

FREE AIR TUNNEL JOBS **Rates Expiration Date :**

Effective Dates:

09/01/2018			03/01/2019	03/01/2020
Rate	Fringe	Total	Total	Total
41.95	30.28	72.23	74.98	77.48

CLASSIFICATIONS:

Iron Foreman, Caulking Foreman, Form Foreman, Cement Finishing Foreman, Concrete Foreman, Track Foreman, Cleanup Foreman, Grout Foreman

Effective Dates:

09/01/2018			03/01/2019	03/01/2020
Rate	Fringe	Total	Total	Total
44.45	30.28	74.73	77.48	79.98

CLASSIFICATIONS:

Blaster

Effective Dates:

09/01/2018			03/01/2019	03/01/2020
Rate	Fringe	Total	Total	Total
41.40	30.28	71.68	74.43	76.93

CLASSIFICATIONS:

Top Labor Foreman

Effective Dates:

09/01/2018			03/01/2019	03/01/2020
Rate	Fringe	Total	Total	Total
41.05	30.28	71.33	74.08	76.58

CLASSIFICATIONS:

Skilled Men (including Caulker, Powder Carrier, all other skilled men)

Skilled Men (including Miner, Drill Runner, Iron Man, Conveyor Man, Manintenance Man, Safety Miner, Rigger, Block Layer, Cement Finisher, Tod Man)

Effective Dates:

09/01/2018			03/01/2019	03/01/2020
Rate	Fringe	Total	Total	Total
40.90	30.28	71.18	73.93	76.43

CLASSIFICATIONS:

Semi-Skilled Men (including Bell or Signal Man Top or Bottom, Form Worker & Mover, Concrete Worker, Shaft Man, Tunnel Laborer, Caulker's Helper, all other semi-skilled)

Semi-Skilled Men (including Miner's Helper, Chuck Tender, Track Man, Nipper, Brake Man, Derail Man, Cable Man, Hose Man, Gravel Man, Form Man)

TERRITORY
ENTIRE STATE

NEW JERSEY DEPARTMENT OF LABOR AND WORKFORCE DEVELOPMENT
PREVAILING WAGE RATE DETERMINATION

FREE AIR TUNNEL JOBS Rates Expiration Date :

Effective Dates:

09/01/2018			03/01/2019	03/01/2020
Rate	Fringe	Total	Total	Total
40.50	30.28	70.78	73.53	76.03

CLASSIFICATIONS:

All Others (including Powder Watchman, Change House Attendant, Top Laborer)

DRILL FOR GROUND WATER SUPPLY **Rates Expiration Date :**

The well driller and/or helper may perform all work relative to the construction, finishing, and servicing of wells, pumps and borings for ground water supply. The present methods of well drilling entailing as they do, many diverse job operations calling for drilling, pump discharge, piping, and the operation of various types of related power equipment, shall all be within the job duties and functions of the well driller and/or helper. In the event that an extension of work should occur beyond water well drilling functions, into the field of general construction work, such extension of work would come under the appropriate rates listed elsewhere in this wage determination.

- For Work Hours, Shift Differentials, Overtime Rates, and Recognized Holidays see the "Operating Engineers" section of this wage determination.

Effective Dates:

01/01/2019			07/01/2019
Rate	Fringe	Total	Total
50.52	32.85	83.37	85.72

CLASSIFICATIONS:

Driller

Effective Dates:

01/01/2019			07/01/2019
Rate	Fringe	Total	Total
43.68	32.85	76.53	78.88

CLASSIFICATIONS:

Driller's Helper

OPERATING ENGINEERS MARINE-DREDGING **Rates Expiration Date :**

NOTE: These wage rates only apply to dredging and other marine construction activities occurring in navigable waters and their tributaries.

Boat crews carrying explosive material (dynamite, pourfex, and other similar materials) shall be paid at 120% of the hourly wage rate for hours engaged in handling of said materials. Employees required to possess a Hazardous Material Certification as a condition of employment shall be compensated at 120% of the hourly wage rate.

OVERTIME:

Hours in excess of 40 per week, and all hours on Saturdays and Sundays, shall be paid at time and one-half the hourly rate. All hours on holidays shall be paid at double the hourly rate.

RECOGNIZED HOLIDAYS: New Year's Day, Martin Luther King Day, Good Friday, Memorial Day, July 4th, Labor Day, Veterans' Day, Thanksgiving Day, Christmas Day. Sunday holidays observed the following Monday.

Effective Dates:

10/01/2017

Rate	Fringe	Total
38.18	14.33	52.51

CLASSIFICATIONS:

Lead Dredgerman, Operator, Leverman

Licensed Tug Operator (over 1000 HP)

Effective Dates:

10/01/2017

Rate	Fringe	Total
33.03	13.92	46.95

CLASSIFICATIONS:

Derrick Operator, Spider/Spill Barge Operator

Engineer, Electrician, Chief Welder, Chief Mate

Fill Placer, Operator II

Licensed Boat Operator

Maintenance Engineer

Effective Dates:

10/01/2017

Rate	Fringe	Total
31.09	13.77	44.86

CLASSIFICATIONS:

Certified Welder

TERRITORY
ENTIRE STATE

NEW JERSEY DEPARTMENT OF LABOR AND WORKFORCE DEVELOPMENT
PREVAILING WAGE RATE DETERMINATION

OPERATING ENGINEERS MARINE-DREDGING Rates Expiration Date :

Effective Dates:

10/01/2017

Rate	Fringe	Total
30.24	13.40	43.64

CLASSIFICATIONS:

Mate, Drag Barge Operator, Steward, Assistant Fill Placer

Welder

Effective Dates:

10/01/2017

Rate	Fringe	Total
29.26	13.32	42.58

CLASSIFICATIONS:

Boat Operator

Effective Dates:

10/01/2017

Rate	Fringe	Total
24.30	12.62	36.92

CLASSIFICATIONS:

Shoreman, Deckhand, Rodman, Scowman

MICROSURFACING/SLURRY SEAL Rates Expiration Date :

THESE RATES APPLY IN THE FOLLOWING COUNTIES ONLY:

Atlantic, Burlington, Camden, Cape May, Cumberland, Gloucester, Mercer, Ocean, Salem

IN ALL OTHER COUNTIES use the Heavy and General Laborers - North "Slurry Seal Laborer" rates.

SHIFT DIFFERENTIALS:

Any shift starting at 3:30 PM or later shall receive an additional \$0.35/hr

OVERTIME:

Hours in excess of 8 per day or 40 per week shall be paid at time and one-half the hourly rate. All hours on holidays shall be paid at double the hourly rate.

RECOGNIZED HOLIDAYS: New Year's Day, Washington's Birthday, Memorial Day, July 4th, Labor Day, Presidential Election Day, Veterans' Day, Thanksgiving Day, Christmas Day.

Effective Dates:

03/01/2017

Rate	Fringe	Total
36.50	21.27	57.77

CLASSIFICATIONS:

Foreman

Effective Dates:

03/01/2017

Rate	Fringe	Total
33.80	21.27	55.07

CLASSIFICATIONS:

Box man

Effective Dates:

03/01/2017

Rate	Fringe	Total
31.75	21.27	53.02

CLASSIFICATIONS:

Microsurface/Slurry Preparation

Effective Dates:

03/01/2017

Rate	Fringe	Total
31.75	21.27	53.02

CLASSIFICATIONS:

Squeegee man

TERRITORY
ENTIRE STATE

NEW JERSEY DEPARTMENT OF LABOR AND WORKFORCE DEVELOPMENT
PREVAILING WAGE RATE DETERMINATION

MICROSURFACING/SLURRY SEAL Rates Expiration Date :

Effective Dates:

03/01/2017

Rate	Fringe	Total
30.30	21.27	51.57

CLASSIFICATIONS:

Cleaner, Taper

ASPHALT LABORERS - SOUTH Rates Expiration Date :

"THESE RATES APPLY IN THE FOLLOWING COUNTIES ONLY: Atlantic, Burlington, Camden, Cape May, Cumberland, Gloucester, Mercer, Ocean, Salem

{For apprentice rates refer to "Laborer - Heavy & General" apprentice rates in any county rate package}

The regular workday consists of 8 hours, starting at 7:00 AM or 8:00 AM.

SHIFT DIFFERENTIALS:

- Shifts must start at 3:00 PM, 4:00 PM, 12:00 AM, or 1:00 AM, to be considered shift work, except when the project owner mandates special hours of work in the job specifications, in which case those hours may be considered shift work.
- When such hours are mandated by the project owner, a shift that begins before midnight on Friday and ends on Saturday morning, or that begins at or after 8:00 PM on Sunday and ends on Monday morning may be paid at the shift differential rate.
- Shifts shall receive an additional \$3.00 per hour.

OVERTIME:

- Hours in excess of 8 per day, Monday through Friday, or outside of the regular workday that are not shift work, and all hours on Saturdays, shall be paid at time and one-half the hourly rate. All hours on Sundays and holidays shall be paid at double the hourly rate.
- Four 10-hour days may be worked, Monday through Thursday, at straight time, with Friday used as a make-up day for a day lost to inclement weather. If Friday is not a make-up day, all hours on Friday shall be paid at time and one-half the hourly rate.

RECOGNIZED HOLIDAYS: New Year's Day, Presidents' Day, Memorial Day, July 4th, Labor Day, Presidential Election Day, Veterans' Day, Thanksgiving Day, Christmas Day. Sunday holidays observed the following Monday. Veterans Day may be substituted for the day after Thanksgiving. However, in the trading of Veterans Day for the day after Thanksgiving, if overtime is worked on Veterans Day, it shall be paid at double the hourly rate.

Hazardous Waste Work:

- where Level A, B, or C protection is required: + \$3.00/hr
- other Hazardous Waste site: + \$1.00/hr

Effective Dates:

	09/01/2018		03/01/2019	03/01/2020
Rate	Fringe	Total	Total	Total
42.25	30.28	72.53	75.28	77.78

CLASSIFICATIONS:

Paving Foreman

Effective Dates:

	09/01/2018		03/01/2019	03/01/2020
Rate	Fringe	Total	Total	Total
40.80	30.28	71.08	73.83	76.33

CLASSIFICATIONS:

Head Raker

Effective Dates:

	09/01/2018		03/01/2019	03/01/2020
Rate	Fringe	Total	Total	Total
40.65	30.28	70.93	73.68	76.18

CLASSIFICATIONS:

Raker, Screedman, Luteman

ASPHALT LABORERS - SOUTH **Rates Expiration Date :**

Effective Dates:

09/01/2018			03/01/2019	03/01/2020
Rate	Fringe	Total	Total	Total
40.40	30.28	70.68	73.43	75.93

CLASSIFICATIONS:

Tampers, Smoothers, Kettlemen,
Painters, Shovelers, Roller Boys

Effective Dates:

09/01/2018			03/01/2019	03/01/2020
Rate	Fringe	Total	Total	Total
40.50	30.28	70.78	73.53	76.03

CLASSIFICATIONS:

Milling Controller

Effective Dates:

09/01/2018			03/01/2019	03/01/2020
Rate	Fringe	Total	Total	Total
40.70	30.28	70.98	73.73	76.23

CLASSIFICATIONS:

Traffic Control Coordinator

TEST BORING PRELIMINARY TO CONSTRUCTION-NORTH **Rates Expiration Date :**

THESE RATES APPLY IN THE FOLLOWING COUNTIES ONLY:
Bergen, Essex, Hudson, Middlesex, Morris, Passaic, Somerset, Union

SHIFT DIFFERENTIAL:

Employees on a shift other than between the hours of 8:00 AM and 5:00 PM shall receive an additional \$1.00 per hour.

OVERTIME:

Hours in excess of 8 per day, Monday through Friday, and all hours on Saturday shall be paid at time and one-half the regular rate. All hours on Sundays and holidays shall be paid at double the regular rate.

RECOGNIZED HOLIDAYS: New Year's Day, Memorial Day, July 4th, Labor Day, Thanksgiving Day, and Christmas Day. Sunday holidays observed the following Monday.

Hazardous Waste Pay (for Levels A, B, and C): an additional 10% of the hourly rate, per hour.

A newly hired Helper with no experience in the industry shall be paid as follows:

- 1st year on the job - 70% of Helper wage rate
- 2nd year on the job - 80% of Helper wage rate
- 3rd year on the job - 90% of Helper wage rate
- All helpers receive full fringe benefit rate.

Effective Dates:

10/17/2017

Rate	Fringe	Total
31.62	25.55	57.17

CLASSIFICATIONS:

Helper (4th year helper)

Effective Dates:

10/17/2017

Rate	Fringe	Total
39.69	25.55	65.24

CLASSIFICATIONS:

Driller

Effective Dates:

10/17/2017

Rate	Fringe	Total
45.73	25.55	71.28

CLASSIFICATIONS:

Foreman

HEAVY & GENERAL LABORERS - NORTH **Rates Expiration Date :**

THESE RATES APPLY IN THE FOLLOWING COUNTIES ONLY:

Bergen, Essex, Hudson, Hunterdon, Middlesex, Monmouth, Morris, Passaic, Somerset, Sussex, Union, Warren

{For apprentice rates refer to "Laborer - Heavy & General" apprentice rates in any county rate package}

The regular workday consists of 8 hours, starting at 7:00 AM or 8:00 AM.

SHIFT DIFFERENTIALS:

- Shifts must start at 3:00 PM, 4:00 PM, 12:00 AM, or 1:00 AM, to be considered shift work, except when the project owner mandates special hours of work in the job specifications, in which case those hours may be considered shift work.
- When such hours are mandated by the project owner, a shift that begins before midnight on Friday and ends on Saturday morning, or that begins at or after 8:00 PM on Sunday and ends on Monday morning may be paid at the shift differential rate.
- Shifts shall receive an additional \$3.00 per hour.

OVERTIME:

- Hours in excess of 8 per day, Monday through Friday, or outside of the regular workday that are not shift work, and all hours on Saturdays, shall be paid at time and one-half the hourly rate. All hours on Sundays and holidays shall be paid at double the hourly rate.
- Four 10-hour days may be worked, Monday through Thursday, at straight time, with Friday used as a make-up day for a day lost to inclement weather. If Friday is not a make-up day, all hours on Friday shall be paid at time and one-half the hourly rate.

RECOGNIZED HOLIDAYS: New Year's Day, Presidents' Day, Memorial Day, July 4th, Labor Day, Presidential Election Day, Veterans' Day, Thanksgiving Day, Christmas Day. Sunday holidays observed the following Monday. Veterans Day may be substituted for the day after Thanksgiving. However, in the trading of Veterans Day for the day after Thanksgiving, if overtime is worked on Veterans Day, it shall be paid at double the hourly rate.

Hazardous Waste Work:

- where Level A, B, or C protection is required: + \$3.00/hr
- other Hazardous Waste site: + \$1.00/hr

Effective Dates:

	09/01/2018		03/01/2019	03/01/2020
Rate	Fringe	Total	Total	Total
40.00	30.28	70.28	73.03	75.53

CLASSIFICATIONS:

"D" Rate:

basic, landscape, asphalt, slurry seal, or railroad track laborer; utility meter installer; flagman; salamander tender; pitman; dumpman; rakers or tampers on cold patch work; wrappers or coatiers of pipe; waterproofer; timberman; wagon drill or drill master helper; powder carrier; magazine tender; signal man; power buggy operator; tree cutter; operator of basic power tools

Effective Dates:

	09/01/2018		03/01/2019	03/01/2020
Rate	Fringe	Total	Total	Total
40.70	30.28	70.98	73.73	76.23

CLASSIFICATIONS:

"C" Rate:

pipe layer; laser man; conduit or duct line layer; operator of jack hammer, chipping hammer, pavement breaker, concrete cutter, asphalt cutter, sheet hammer, or walk-behind saw cutter; sandblaster; acetylene cutting or burning; wagon drill, directional drill, or hydraulic drill operator; drill master; core driller; traffic control coordinator; asphalt raker or lute man

HEAVY & GENERAL LABORERS - NORTH **Rates Expiration Date :**

Effective Dates:

09/01/2018			03/01/2019	03/01/2020
Rate	Fringe	Total	Total	Total
40.95	30.28	71.23	73.98	76.48

CLASSIFICATIONS:

"B" Rate:

concrete finisher; setter of brick or stone pavers; stone cutter; form setter; manhole, catch basin, or inlet builder; asphalt screedman; rammer; hardscaping; gunite nozzle man

Effective Dates:

09/01/2018			03/01/2019	03/01/2020
Rate	Fringe	Total	Total	Total
44.50	30.28	74.78	77.53	80.03

CLASSIFICATIONS:

"A" Rate:

blaster

Effective Dates:

09/01/2018			03/01/2019	03/01/2020
Rate	Fringe	Total	Total	Total
42.25	30.28	72.53	75.28	77.78

CLASSIFICATIONS:

"FOREMAN" Rate:

labor foreman, asphalt foreman, drill foreman, pipe foreman, grade foreman, finisher foreman, concrete foreman

Effective Dates:

09/01/2018			03/01/2019	03/01/2020
Rate	Fringe	Total	Total	Total
43.25	30.28	73.53	76.28	78.78

CLASSIFICATIONS:

"GENERAL FOREMAN" Rate

HEAVY & GENERAL LABORERS - SOUTH **Rates Expiration Date :**

THESE RATES APPLY IN THE FOLLOWING COUNTIES ONLY:

Atlantic, Burlington, Camden, Cape May, Cumberland, Gloucester, Mercer, Ocean, Salem

{For apprentice rates refer to "Laborer - Heavy & General" apprentice rates in any county rate package}

The regular workday consists of 8 hours, starting at 7:00 AM or 8:00 AM.

SHIFT DIFFERENTIALS:

- Shifts must start at 3:00 PM, 4:00 PM, 12:00 AM, or 1:00 AM, to be considered shift work, except when the project owner mandates special hours of work in the job specifications, in which case those hours may be considered shift work.
- When such hours are mandated by the project owner, a shift that begins before midnight on Friday and ends on Saturday morning, or that begins at or after 8:00 PM on Sunday and ends on Monday morning may be paid at the shift differential rate.
- Shifts shall receive an additional \$3.00 per hour.

OVERTIME:

- Hours in excess of 8 per day, Monday through Friday, or outside of the regular workday that are not shift work, and all hours on Saturdays, shall be paid at time and one-half the hourly rate. All hours on Sundays and holidays shall be paid at double the hourly rate.
- Four 10-hour days may be worked, Monday through Thursday, at straight time, with Friday used as a make-up day for a day lost to inclement weather. If Friday is not a make-up day, all hours on Friday shall be paid at time and one-half the hourly rate.

RECOGNIZED HOLIDAYS: New Year's Day, Presidents' Day, Memorial Day, July 4th, Labor Day, Presidential Election Day, Veterans' Day, Thanksgiving Day, Christmas Day. Sunday holidays observed the following Monday. Veterans Day may be substituted for the day after Thanksgiving. However, in the trading of Veterans Day for the day after Thanksgiving, if overtime is worked on Veterans Day, it shall be paid at double the hourly rate.

Hazardous Waste Work:

- where Level A, B, or C protection is required: + \$3.00/hr
- other Hazardous Waste site: + \$1.00/hr

Effective Dates:

	09/01/2018		03/01/2019	03/01/2020
Rate	Fringe	Total	Total	Total
40.00	30.28	70.28	73.03	75.53

CLASSIFICATIONS:

basic, landscape, or railroad track laborer; utility meter installer; flagman; salamander tender; pitman; dumpman; rakers or tampers on cold patch work; wrappers or coaters of pipe; waterproofers; tree cutter, timberman

Effective Dates:

	09/01/2018		03/01/2019	03/01/2020
Rate	Fringe	Total	Total	Total
40.00	30.28	70.28	73.03	75.53

CLASSIFICATIONS:

wagon drill or drill master helper; powder carrier; magazine tender; signal man

HEAVY & GENERAL LABORERS - SOUTH **Rates Expiration Date :**

Effective Dates:

09/01/2018			03/01/2019	03/01/2020
Rate	Fringe	Total	Total	Total
40.70	30.28	70.98	73.73	76.23

CLASSIFICATIONS:

pipe layer; laser man; conduit or duct line layer; operator of jack hammer, chipping hammer, pavement breaker, concrete cutter, asphalt cutter, sheet hammer, or walk-behind saw cutter; sandblaster; acetylene cutting or burning

Effective Dates:

09/01/2018			03/01/2019	03/01/2020
Rate	Fringe	Total	Total	Total
40.70	30.28	70.98	73.73	76.23

CLASSIFICATIONS:

wagon or directional drill operator; drill master

Effective Dates:

09/01/2018			03/01/2019	03/01/2020
Rate	Fringe	Total	Total	Total
44.50	30.28	74.78	77.53	80.03

CLASSIFICATIONS:

blaster

Effective Dates:

09/01/2018			03/01/2019	03/01/2020
Rate	Fringe	Total	Total	Total
42.25	30.28	72.53	75.28	77.78

CLASSIFICATIONS:

labor foreman, drill foreman, pipe foreman, grade foreman, finisher foreman, concrete foreman

Effective Dates:

09/01/2018			03/01/2019	03/01/2020
Rate	Fringe	Total	Total	Total
43.25	30.28	73.53	76.28	78.78

CLASSIFICATIONS:

general foreman

TERRITORY
ENTIRE STATE

NEW JERSEY DEPARTMENT OF LABOR AND WORKFORCE DEVELOPMENT
PREVAILING WAGE RATE DETERMINATION

HEAVY & GENERAL LABORERS - SOUTH Rates Expiration Date :

Effective Dates:

09/01/2018			03/01/2019	03/01/2020
Rate	Fringe	Total	Total	Total
40.95	30.28	71.23	73.98	76.48

CLASSIFICATIONS:

concrete finisher; setter of brick or stone pavers; stone cutter; form setter; manhole, catch basin, or inlet builder; rammer; gunite nozzle man

PIPELINE - MAINLINE TRANSMISSION Rates Expiration Date :

These rates apply to the following: welding on Transportation Mainline pipe lines (cross-country pipe lines, or any segments thereof, transporting coal, gas, oil, water or other transportable materials, vapors or liquids, including portions of such pipe lines within private property boundaries up to the final metering station or connection - the point where a valve, consumer connection, or town border station divides mainline transmission lines or higher pressure lateral and branch lines from lower pressure distribution systems).

PER DIEM PAYMENT:

In addition to the total wage rate paid for each craft, the following per diem (per day) amounts must also be paid - Pipeline Journeyman: \$42.50; Pipeline Journeyman Welder: \$102.50; and Pipeline Helper: \$42.50. Note: in order to receive the per diem payment an employee must work a minimum of 8 hours in a 24 hour period.

NOTES:

- Journeymen employed as "stringer bead" welders and journeymen who are regularly employed as "hot-pass" welders shall receive \$1.00 per hour more than other journeymen.
- Welders running "stringer bead" or "hot-pass" on "cutouts" or "tie-ins" on a production basis shall be paid \$1.00 per hour above the journeymen rate.
- Whenever a welder helper is employed using a power buffer or power grinder immediately behind the stringer bead and/or hot-pass welders, and the pipe gang is set on a production basis, the helper shall be paid \$2.00 per hour above the helper rate.
- If back welding is performed inside a pipe under either or both of the following conditions, the welder engaged in the welding will receive \$3.00 per hour above the regular rate for the job only for the days on which such back welding is performed:
 - The employer elects, as a regular procedure, to back weld each line-up. This condition is not intended to apply to occasional back welding performed by the pipe gang to repair a bead, to rectify a "high-lo" condition or wall thickness, etc.
 - A welder is required to back weld a completed weld behind the firing line.
- If the welder helper is required to go inside the pipe for the purpose of brushing, buffing and grinding the weld, they shall receive a wage rate \$1.00 per hour above the regular helper rate for the days involved.
- Welders working on "hot work" shall be paid \$2.00 per hour above the regular rate for each day engaged in such work. "Hot work" is defined as work on lines in service where there is the danger of fire or explosion.

The regular workday shall be 8 hours, between 8:00 AM and 4:30 PM.

OVERTIME:

Hours in excess of 8 per day, and all hours on Sundays shall be paid at time and one-half the regular rate, inclusive of benefits. All hours on holidays shall be paid at double the regular rate, inclusive of benefits.

RECOGNIZED HOLIDAYS: New Year's Day, July 4th, Labor Day, Thanksgiving Day, and Christmas Day. Sunday holidays observed the following Monday.

Effective Dates:

06/08/2018

Rate	Fringe	Total
54.61	29.59	84.20

CLASSIFICATIONS:

Pipeline Journeyman Welder

TERRITORY
ENTIRE STATE

NEW JERSEY DEPARTMENT OF LABOR AND WORKFORCE DEVELOPMENT
PREVAILING WAGE RATE DETERMINATION

PIPELINE - MAINLINE TRANSMISSION Rates Expiration Date :

Effective Dates:

06/08/2018

Rate	Fringe	Total
54.61	29.59	84.20

CLASSIFICATIONS:

Pipeline Journeyman

Effective Dates:

06/08/2018

Rate	Fringe	Total
33.55	20.42	53.97

CLASSIFICATIONS:

Pipeline Helper

PIPELINE - GAS DISTRIBUTION **Rates Expiration Date :**

These rates apply to the following: welding on gas line distribution systems (that portion of the gas distribution system placed in streets, roads, subways, tunnels, viaducts, highways and easements which serves the users of gas).

SHIFT DIFFERENTIALS:

An "irregular" shift may start any time from 5:00 PM to 12:00 AM, Monday through Friday, and shall receive an additional 15% of the regular rate per hour, inclusive of benefits.

OVERTIME:

Hours in excess of forty per week, and all hours on Saturdays shall be paid at time and one-half the regular rate, inclusive of benefits. All hours on Sundays and holidays shall be paid at double the regular rate, inclusive of benefits.

RECOGNIZED HOLIDAYS: New Year's Day, Memorial Day, July 4th, Labor Day, Thanksgiving Day, and Christmas Day. Sunday holidays observed the following Monday.

Effective Dates:

11/01/2018			11/01/2019
Rate	Fringe	Total	Total
60.00	23.73	83.73	86.23

CLASSIFICATIONS:

Pipeline Journeyman Welder

Effective Dates:

11/01/2018			11/01/2019
Rate	Fringe	Total	Total
60.00	23.73	83.73	86.23

CLASSIFICATIONS:

Pipeline Journeyman

Effective Dates:

11/01/2018			11/01/2019
Rate	Fringe	Total	Total
38.46	17.54	56.00	57.67

CLASSIFICATIONS:

Pipeline Helper

ASPHALT LABORERS- NORTH **Rates Expiration Date :**

THESE RATES APPLY IN THE FOLLOWING COUNTIES ONLY:

Bergen, Essex, Hudson, Hunterdon, Middlesex, Monmouth, Morris, Passaic, Somerset, Sussex, Union, Warren

{For apprentice rates refer to "Laborer - Heavy & General" apprentice rates in any county rate package}

The regular workday consists of 8 hours, starting at 7:00 AM or 8:00 AM.

SHIFT DIFFERENTIALS:

- Shifts must start at 3:00 PM, 4:00 PM, 12:00 AM, or 1:00 AM, to be considered shift work, except when the project owner mandates special hours of work in the job specifications, in which case those hours may be considered shift work.
- When such hours are mandated by the project owner, a shift that begins before midnight on Friday and ends on Saturday morning, or that begins at or after 8:00 PM on Sunday and ends on Monday morning may be paid at the shift differential rate.
- Shifts shall receive an additional \$3.00 per hour.

OVERTIME:

- Hours in excess of 8 per day, Monday through Friday, or outside of the regular workday that are not shift work, and all hours on Saturdays, shall be paid at time and one-half the hourly rate. All hours on Sundays and holidays shall be paid at double the hourly rate.
- Four 10-hour days may be worked, Monday through Thursday, at straight time, with Friday used as a make-up day for a day lost to inclement weather. If Friday is not a make-up day, all hours on Friday shall be paid at time and one-half the hourly rate.

RECOGNIZED HOLIDAYS: New Year's Day, Presidents' Day, Memorial Day, July 4th, Labor Day, Presidential Election Day, Veterans' Day, Thanksgiving Day, Christmas Day. Sunday holidays observed the following Monday. Veterans Day may be substituted for the day after Thanksgiving. However, in the trading of Veterans Day for the day after Thanksgiving, if overtime is worked on Veterans Day, it shall be paid at double the hourly rate.

Hazardous Waste Work:

- where Level A, B, or C protection is required: + \$3.00/hr
- other Hazardous Waste site: + \$1.00/hr

Effective Dates:

	09/01/2018		03/01/2019	03/01/2020
Rate	Fringe	Total	Total	Total
42.25	30.28	72.53	75.28	77.78

CLASSIFICATIONS:

Asphalt Foreman

Effective Dates:

	09/01/2018		03/01/2019	03/01/2020
Rate	Fringe	Total	Total	Total
40.95	30.28	71.23	73.98	76.48

CLASSIFICATIONS:

Asphalt Screedman

Effective Dates:

	09/01/2018		03/01/2019	03/01/2020
Rate	Fringe	Total	Total	Total
40.70	30.28	70.98	73.73	76.23

CLASSIFICATIONS:

Asphalt Raker or Lute Man

TERRITORY
ENTIRE STATE

NEW JERSEY DEPARTMENT OF LABOR AND WORKFORCE DEVELOPMENT
PREVAILING WAGE RATE DETERMINATION

ASPHALT LABORERS- NORTH Rates Expiration Date :

Effective Dates:

09/01/2018			03/01/2019	03/01/2020
Rate	Fringe	Total	Total	Total
40.00	30.28	70.28	73.03	75.53

CLASSIFICATIONS:

Asphalt Laborer

ELECTRICIAN- UTILITY WORK (NORTH) **Rates Expiration Date :**

Electrician-Utility Work (North)

(For apprentice rates refer to Electrician-Utility Work (North) in any county rate package).

These rates apply to work contracted for by the following utility companies:

Public Service Electric & Gas Co. of NJ, GPU Energy, Borough of Madison Electric Department, Sussex Rural Electric Cooperative, Rockland Utilities, and Butler Municipal Electric Co.

These rates do not apply to work on substations or switching stations.

For Utility work contracted for by a utility company other than those listed above or those listed under "Electrician-Utility Work (South), see the "Outside Commercial Rates" for the county in which the jobsite is located.

* FOR OUTSIDE COMMERCIAL RATES PLEASE SEE COUNTY RATES

The regular workday is 8 hours, between 6:00 AM and 6:00 PM.

FOR EMERGENCY WORK ONLY: (emergency work is defined as work caused by storm, catastrophe, act of god, and circumstances beyond the control of the employer)-all hours of work shall be paid at double the hourly rate.

SHIFT DIFFERENTIALS:

Shift work must run for a minimum of 5 consecutive workdays.

2nd shift (between the hours of 4:30 PM and 1:00 AM): 8 hours of work + 17.3% of the regular rate, inclusive of benefits.

3rd shift (between the hours of 12:30 AM and 9:00 AM): 8 hours of work + 31.4% of the regular rate per hour, inclusive of benefits.

OVERTIME:

Hours in excess of 8 per day, or before or after the regular workday Monday through Friday, that is not shift work, and all hours on Saturday shall be paid at time and one-half the regular rate, inclusive of benefits. All hours on Sundays and holidays shall be paid at double the hourly rate, inclusive of benefits.

Four 10-hour days may worked, at straight time, between 7:00 AM and 6:30 PM, Monday through Thursday.

RECOGNIZED HOLIDAYS:

New Year's Day, Presidents' Day, Memorial Day, July 4th, Labor Day, Presidential Election Day, Veterans' Day, Thanksgiving Day and Christmas Day, or day on which they are legally observed.

Effective Dates:

	12/02/2018		12/01/2019	11/29/2020
Rate	Fringe	Total	Total	Total
55.13	36.93	92.06	94.45	96.84

CLASSIFICATIONS:

Chief Lineman

Effective Dates:

	12/02/2018		12/01/2019	11/29/2020
Rate	Fringe	Total	Total	Total
52.01	34.84	86.85	89.11	91.36

CLASSIFICATIONS:

Journeyman Lineman

ELECTRICIAN- UTILITY WORK (NORTH) **Rates Expiration Date :**

Effective Dates:

12/02/2018			12/01/2019	11/29/2020
Rate	Fringe	Total	Total	Total
52.01	34.84	86.85	89.11	91.36

CLASSIFICATIONS:

Special License Operator

Effective Dates:

12/02/2018			12/01/2019	11/29/2020
Rate	Fringe	Total	Total	Total
51.49	34.49	85.98	88.22	90.44

CLASSIFICATIONS:

Transit Man

Effective Dates:

12/02/2018			12/01/2019	11/29/2020
Rate	Fringe	Total	Total	Total
49.93	33.45	83.38	85.53	87.70

CLASSIFICATIONS:

Line Equipment Operator

Effective Dates:

12/02/2018			12/01/2019	11/29/2020
Rate	Fringe	Total	Total	Total
43.69	29.27	72.96	74.84	76.73

CLASSIFICATIONS:

Dynamite Man

Effective Dates:

12/02/2018			12/01/2019	11/29/2020
Rate	Fringe	Total	Total	Total
65.01	43.55	108.56	111.38	114.19

CLASSIFICATIONS:

General Foreman

Effective Dates:

12/02/2018			12/01/2019	11/29/2020
Rate	Fringe	Total	Total	Total
59.81	40.07	99.88	102.47	105.05

CLASSIFICATIONS:

Assistant General Foreman

ELECTRICIAN- UTILITY WORK (NORTH) **Rates Expiration Date :**

Effective Dates:

12/02/2018			12/01/2019	11/29/2020
Rate	Fringe	Total	Total	Total
58.25	39.02	97.27	99.79	102.32

CLASSIFICATIONS:

Line Foreman

Effective Dates:

12/02/2018			12/01/2019	11/29/2020
Rate	Fringe	Total	Total	Total
42.13	28.22	70.35	72.17	73.99

CLASSIFICATIONS:

Street Light Mechanical Leader

Effective Dates:

12/02/2018			12/01/2019	11/29/2020
Rate	Fringe	Total	Total	Total
40.05	26.83	66.88	68.62	70.34

CLASSIFICATIONS:

Groundman Winch Operator

Effective Dates:

12/02/2018			12/01/2019	11/29/2020
Rate	Fringe	Total	Total	Total
40.05	26.83	66.88	68.62	70.34

CLASSIFICATIONS:

Groundman Truck Operator

Effective Dates:

12/02/2018			12/01/2019	11/29/2020
Rate	Fringe	Total	Total	Total
39.53	26.48	66.01	67.71	69.43

CLASSIFICATIONS:

Street Light Mechanic

Effective Dates:

12/02/2018			12/01/2019	11/29/2020
Rate	Fringe	Total	Total	Total
39.53	26.48	66.01	67.71	69.43

CLASSIFICATIONS:

Line Equipment Mechanic

ELECTRICIAN- UTILITY WORK (NORTH) **Rates Expiration Date :**

Effective Dates:

12/02/2018			12/01/2019	11/29/2020
Rate	Fringe	Total	Total	Total
33.81	22.65	56.46	57.91	59.38

CLASSIFICATIONS:

Groundman 2nd Year

Effective Dates:

12/02/2018			12/01/2019	11/29/2020
Rate	Fringe	Total	Total	Total
31.21	20.91	52.12	53.47	54.80

CLASSIFICATIONS:

Groundman 1st Year

Effective Dates:

12/02/2018			12/01/2019	11/29/2020
Rate	Fringe	Total	Total	Total
51.49	34.49	85.98	88.22	90.44

CLASSIFICATIONS:

Line Equipment Foreman

ELECTRICIAN- UTILITY WORK (SOUTH) **Rates Expiration Date :**

Electrician-Utility Work (South)

(For apprentice rates refer to Electrician-Utility Work (South) in any county rate package).

These rates apply to work contracted for by the following utility company:

Atlantic City Electric.

These rates do not apply to work on substations or switching stations.

For utility work contracted for by a utility company other than the one listed above or those listed under "Electrician-Utility Work (North), see the "Outside Commercial Rates" for the county in which the jobsite is located.

* FOR OUTSIDE COMMERCIAL RATES PLEASE SEE COUNTY RATES

The regular workday is 8 hours, between 7:00 AM and 4:30 PM.

FOR EMERGENCY WORK ONLY: (emergency work is defined as work caused by storm, catastrophe, act of god, and circumstances beyond the control of the employer)- all hours of work shall be paid at double the hourly rate.

SHIFT DIFFERENTIALS:

Shift work must run for a minimum of 5 consecutive workdays.

When two (2) or three (3) shifts are worked the following shall apply:

1st shift (between the hours of 8:00 AM and 4:30 PM)

2nd shift (between the hours of 4:30 PM and 12:30 AM): 8 hours of work + 10% of the regular rate of pay for 7.5 hours worked.

3rd shift (between the hours of 12:30 AM and 8:00 AM): 8 hours of work + 15% of the regular rate of pay for 7 hours worked.

OVERTIME:

Hours in excess of 8 per day, or before or after the regular workday Monday through Friday, that is not shift work, and all hours on Saturday shall be paid at time and one-half the regular rate. All hours on Sundays and Holidays shall be paid double the hourly rate.

Four 10-hour days may be worked, at straight time, between 6:00 AM and 6:00 PM, Monday through Thursday with Friday used as a make-up day.

RECOGNIZED HOLIDAYS:

New Year's Day, Memorial Day, July 4th, Labor Day, Veterans' Day, Thanksgiving Day and Christmas Day or on days celebrated.

WORKING RULES:

There shall be a Foreman in charge of each work crew. No crews are to exceed twelve (12) men, including Foremen.

There shall be a General Foreman designated for transmission work when three (3) or more crews are on the same job and for distribution work where there are more than twenty (20) employees on site.

A small job crew shall consist of five (5) or less employees, one (1) of the Journeyman Linemen in the crew shall be designated as a Small Job Foreman.

Work performed from ladders and/or mechanical lift equipment shall be the work of Linemen and/or Apprentices.

On new construction, fitting and framing poles, towers or structures may be done by Journeymen and/or Apprentices. Groundmen may assist, but may not perform any work which would be performed by Linemen if assembled in the air.

There shall be a Journeyman Lineman in each pole setting, erection, grounding, wire and cable-pulling crew of more than three (3) men.

Effective Dates:

12/02/2018

Rate	Fringe	Total
60.86	48.05	108.91

CLASSIFICATIONS:

General Foreman

ELECTRICIAN- UTILITY WORK (SOUTH) **Rates Expiration Date :**

Effective Dates:

12/02/2018

Rate	Fringe	Total
54.21	44.12	98.33

CLASSIFICATIONS:

Foreman

Effective Dates:

12/02/2018

Rate	Fringe	Total
51.35	42.44	93.79

CLASSIFICATIONS:

Small Job Foreman

Effective Dates:

12/02/2018

Rate	Fringe	Total
47.55	40.18	87.73

CLASSIFICATIONS:

Heavy Equipment Operator

Effective Dates:

12/02/2018

Rate	Fringe	Total
47.55	40.18	87.73

CLASSIFICATIONS:

Cable Splicer

Effective Dates:

12/02/2018

Rate	Fringe	Total
47.55	40.18	87.73

CLASSIFICATIONS:

Journeyman Lineman

Effective Dates:

12/02/2018

Rate	Fringe	Total
47.55	40.18	87.73

CLASSIFICATIONS:

Journeyman Welder

ELECTRICIAN- UTILITY WORK (SOUTH) Rates Expiration Date :

Effective Dates:

12/02/2018

Rate	Fringe	Total
47.55	40.18	87.73

CLASSIFICATIONS:

Journeyman Painter

Effective Dates:

12/02/2018

Rate	Fringe	Total
38.04	34.55	72.59

CLASSIFICATIONS:

Light Equipment Operator

Effective Dates:

12/02/2018

Rate	Fringe	Total
33.29	31.73	65.02

CLASSIFICATIONS:

Groundman Truck Driver

Effective Dates:

12/02/2018

Rate	Fringe	Total
30.91	30.31	61.22

CLASSIFICATIONS:

Groundman 3rd Year

Effective Dates:

12/02/2018

Rate	Fringe	Total
28.53	28.91	57.44

CLASSIFICATIONS:

Groundman 2nd Year

Effective Dates:

12/02/2018

Rate	Fringe	Total
26.15	27.51	53.66

CLASSIFICATIONS:

Groundman 1st Year

TERRITORY
ENTIRE STATE

NEW JERSEY DEPARTMENT OF LABOR AND WORKFORCE DEVELOPMENT
PREVAILING WAGE RATE DETERMINATION

ELECTRICIAN- UTILITY WORK (SOUTH) Rates Expiration Date :

Effective Dates:

12/02/2018

Rate	Fringe	Total
20.92	24.41	45.33

CLASSIFICATIONS:

Flagman

HEAVY & GENERAL LABORERS- NEW TRANS HUDSON TUNNELS Rates Expiration Date :

****THESE RATES APPLY TO CONSTRUCTION ON NEW TRANS HUDSON TUNNELS ONLY****

{For apprentice rates refer to "Laborer - Heavy & General" apprentice rates in any county rate package}

The regular workday consists of 8 hours, starting at 7:00 AM or 8:00 AM.

SHIFT DIFFERENTIALS:

- Shifts must start at 3:00 PM, 4:00 PM, 12:00 AM, or 1:00 AM, to be considered shift work, except when the project owner mandates special hours of work in the job specifications, in which case those hours may be considered shift work.
- When such hours are mandated by the project owner, a shift that begins before midnight on Friday and ends on Saturday morning, or that begins at or after 8:00 PM on Sunday and ends on Monday morning may be paid at the shift differential rate.
- Shifts shall receive an additional \$3.00 per hour.

OVERTIME:

- Hours in excess of 8 per day, Monday through Friday, or outside of the regular workday that are not shift work, and all hours on Saturdays, shall be paid at time and one-half the hourly rate. All hours on Sundays and holidays shall be paid at double the hourly rate.
- Four 10-hour days may be worked, Monday through Thursday, at straight time, with Friday used as a make-up day for a day lost to inclement weather. If Friday is not a make-up day, all hours on Friday shall be paid at time and one-half the hourly rate.

RECOGNIZED HOLIDAYS: New Year's Day, Presidents' Day, Memorial Day, July 4th, Labor Day, Presidential Election Day, Veterans' Day, Thanksgiving Day, Christmas Day. Sunday holidays observed the following Monday. Veterans Day may be substituted for the day after Thanksgiving. However, in the trading of Veterans Day for the day after Thanksgiving, if overtime is worked on Veterans Day, it shall be paid at double the hourly rate.

Hazardous Waste Work:

- where Level A, B, or C protection is required: + \$3.00/hr
- other Hazardous Waste site: + \$1.00/hr

Effective Dates:

	09/01/2018		03/01/2019	03/01/2020
Rate	Fringe	Total	Total	Total
64.13	30.28	94.41	97.91	101.16

CLASSIFICATIONS:

Walking Boss & Superintendent

Effective Dates:

	09/01/2018		03/01/2019	03/01/2020
Rate	Fringe	Total	Total	Total
63.68	30.28	93.96	97.46	100.71

CLASSIFICATIONS:

Heading Foreman, Shaft Foreman, Rod Foreman, Electrical Foreman, Rigging Foreman

HEAVY & GENERAL LABORERS- NEW TRANS HUDSON TUNNELS **Rates Expiration Date :**

Effective Dates:

09/01/2018			03/01/2019	03/01/2020
Rate	Fringe	Total	Total	Total
62.93	30.28	93.21	96.71	99.96

CLASSIFICATIONS:

Iron Foreman, Caulking Foreman, Form Foreman, Cement Finishing Foreman, Concrete Foreman, Track Foreman, Clean-up Foreman, Grout Foreman

Effective Dates:

09/01/2018			03/01/2019	03/01/2020
Rate	Fringe	Total	Total	Total
66.68	30.28	96.96	100.46	103.71

CLASSIFICATIONS:

Blaster

Effective Dates:

09/01/2018			03/01/2019	03/01/2020
Rate	Fringe	Total	Total	Total
62.10	30.28	92.38	95.88	99.13

CLASSIFICATIONS:

Top Labor Foreman

Effective Dates:

09/01/2018			03/01/2019	03/01/2020
Rate	Fringe	Total	Total	Total
61.58	30.28	91.86	95.36	98.61

CLASSIFICATIONS:

Skilled Men (including Caulker, Powder Carrier, all other skilled men)

Skilled Men (including Miner, Drill Runner, Iron Man, Conveyor Man, Maintenance Man, Safety Miner, Rigger, Block Layer, Cement Finisher, Rod Man)

Effective Dates:

09/01/2018			03/01/2019	03/01/2020
Rate	Fringe	Total	Total	Total
61.35	30.28	91.63	95.13	98.38

CLASSIFICATIONS:

Semi-Skilled Men (including Bell or Signal Man top or bottom, Form Worker & Mover, Concrete Worker, Shaft Man, Tunnel Laborer, Caulker's Helper, all other semi-skilled)

Semi-Skilled Men (including Miner's Helper, Chuck Tender, Track Man, Nipper, Brake Man, Derail Man, Cable Man, Hose Man, Gravel Man, Form Man)

TERRITORY
ENTIRE STATE

NEW JERSEY DEPARTMENT OF LABOR AND WORKFORCE DEVELOPMENT
PREVAILING WAGE RATE DETERMINATION

HEAVY & GENERAL LABORERS- NEW TRANS HUDSON TUNNELS Rates Expiration Date :

Effective Dates:

09/01/2018			03/01/2019	03/01/2020
Rate	Fringe	Total	Total	Total
60.75	30.28	91.03	94.53	97.78

CLASSIFICATIONS:

All others (including Powder Watchman, Change House Attendant, Top Laborer, Job Steward)

GALLOPING HILL G. C. 2019 IRRIGATION IMPROVEMENT PROJECT KENILWORTH, NEW JERSEY

TECHNICAL SPECIFICATIONS

1.0 GENERAL

A) Qualification of Irrigation Installer

In determining the qualifications of the Irrigation Installer, the Owner will consider his/her record in the performance of other contracts with the Owner and other public or private bodies. Any Subcontractors to be used for this project must be listed on the proposal page. The Owner expressly reserves the right to reject a bidder and/or subcontractor if their record discloses that they do not meet the experience requirement, or have not properly performed any contracts in the opinion of the Owner, or that they have habitually and without just cause neglected the payment of bills, or that they have otherwise disregarded their obligations to subcontractors, suppliers, or employees.

The Irrigation Installer must demonstrate to the Owner's satisfaction that they are experienced at performing the irrigation work required in the project. The Irrigation Installer shall provide a list of references from five similar or larger golf course irrigation projects that were installed within the past three years. Listed projects shall have included the complete installation of multiple row, fully automatic central based irrigation systems on comparable golf courses. The Irrigation Installer must be able to demonstrate experience in the installation of Rain Bird Golf Sprinklers and Central/Satellite control systems and must have the ability to provide GPS data collection and map image creation services.

The Owner will make such investigations, as it deems necessary to determine the Irrigation Installer's ability to perform the work. The Irrigation Installer shall furnish to the Owner all information and data that the Owner may request for this purpose. The Owner reserves the right to reject the Irrigation Installer if evidence submitted by, or investigation of, the Irrigation Installer fails to satisfy the Owner that the Irrigation Installer is properly qualified to carry out all the obligations required by the project. The Irrigation Contractor must also be certified by NJ State as a Licensed Landscape Irrigation Installer. Copy of NJ License and Business Permit must be submitted with all bids.

B) Description of System

Galloping Hill Golf Course is an existing private 18-hole championship golf course and 9-hole learning course, owned by the County of Union. Currently an expanded double row Rain Bird automatic sprinkler system exists and major key

components of it will be salvaged for re-use in the new system. The irrigation improvements depicted in these bid documents are necessary to correct deficiencies in the existing system infrastructure in order to properly irrigate the improved features of the golf course.

Installation of this system will require the highest quality of labor and components. It is imperative that all work proceed in a timely manner. Strict deadlines will be set by the owner and adhered to by the installer.

C) Installer's Representative

The Irrigation Installer shall keep a technically qualified irrigation superintendent on the site full time for the entire duration of this project. This superintendent shall be experienced in the type of work required by the project and must be familiar with the Contract Documents. This individual shall be the Irrigation Installer's Representative in all matters relating to the irrigation installation. The superintendent shall be acceptable to the Owner. The superintendent shall supervise in the field all work performed by the Irrigation Installer's employees or subcontractors. The superintendent shall consult the Owner and the Irrigation Consultant regarding all work to be performed. The Installer's Representative shall abide by the Owner's directions in all matters in which the Owner's approval or direction is specified.

D) Scope of Work

The Irrigation Contractor shall install all irrigation system improvements in accordance with the Plans and other Contract Documents, the manufacturer's recommended procedures, industry standards and the direction and instructions of the Owner's Representative in the field. The work shall include, but is not limited to, the following:

1. Furnishing, delivery, assembly and secure storage of materials.
2. Cutting Sod, Trenching or pulling, backfilling restoration.
3. Removal of irrigation pump panel for salvage and re-use.
4. Removal of existing pump station skid from pump house for disposal off site.
5. Furnish and Installation of new Watertronics pump skid per specs, compatible with existing control panel.
6. Re-install and re-wire existing Watertronics pump control panel for re-use on new pump skid.
7. Furnish and Installation of irrigation control wire, power wire, and grounding,

new Rain Bird Par + ES Controller for holes #10 and #18. Preparation of GPS Record Drawings and GPS map image creation.

8. Testing of completed system and verification of proper system operation and warranty all products and workmanship according to specifications.

E) Coordination

The Irrigation Installer, through his on site superintendent, shall coordinate all work with the Designer, the Owner's Representative, and supplier and any other contractors on the site. The Owner's Representative must give prior approval to the installer for any water use whatsoever.

F) Provide Materials

All irrigation material, including pump skid, wire, etc. shall be as specified, no alternates will be accepted. It is the intent of the owner to limit the products to only those specified in order to ultimately achieve a consistently uniform installation at the completion various phases of implementation. The installer will coordinate all deliveries to the site and offload and store and protect all equipment, materials and components necessary for the installation of a fully automatic irrigation system as indicated in the plans and specifications.

All wire and pump skid must be stored off the ground and care shall be taken to keep the pump skid clean and free of debris. The irrigation installer shall provide security for all irrigation materials on site. Receive and unload all materials that are shipped to the site. Provide all labor, forklifts, crane and/or any other equipment required to properly and safely unload all materials. All material overages at the completion of the project are the property of the Contractor, who shall promptly remove them from the site.

It is requested that all materials be supplied from one distributor (Factory Authorized Rain Bird/Watertronics Golf Distributor) as a package purchase for ease of service, support and warranty administration.

G) Payment for Materials

Refer to General Specifications.

H) Comply With Applicable Codes

Install the entire system in compliance with all local laws, ordinances and established codes applicable to the class of work involved (including OSHA regulations), and enforce on the date of execution of the Agreement. If compliance necessitates a change in design, notify the Owner's Representative immediately, in writing. The Contractor shall secure and pay for all required

permits and licenses necessary to install the irrigation system.

I) Quantities

The quantities shown on the plans have been indicated as closely as possible but are approximate only. The Contractor shall be responsible for preparing his/her own material take-off.

J) Repair and Instruction Obligation

The Contractor must immediately repair any system malfunction that may occur prior to final acceptance of the system by the Owner. During the execution of this contract, keep a technically qualified man on the job full time and maintain adequate labor and equipment at the site to immediately repair the system or components in the event of any leak or failure.

If there should be an interruption in the work and the Contractor leaves the golf course for an extended period of time, ensure that adequate materials are on hand to repair any failure and that Owner's personnel are familiar with performing such repairs in a manner that will not void any warranties. Prior to completion of the job, thoroughly instruct the Owner's personnel in the proper programming, operation, maintenance and repair of the system. Contractor is responsible to cover the cost of setting initial watering schedules in the central controller with field data collected and programmed by a Rain Bird certified programmer.

K) Damage to Other Work and Vegetation

If, in the Owner's opinion, a malfunction or other failure renders the irrigation system or a portion of the system inoperable and this results in erosion, loss of grass, or other damage to the golf course during the construction period, the cost of corrective work necessary to repair, replant, or otherwise return the damaged area to an acceptable condition shall be borne by the Contractor. Driving equipment or vehicles on greens or tees is prohibited. Avoid damage to shrubs, trees and their roots.

Repair, to the satisfaction of the Owner, all ruts and other damage to the course caused by the Contractor's equipment or employees.

L) Adjustment of Plans

It is to be recognized that the irrigation system as staked in the field may differ substantially from the installation plans. Adjust the installation of the irrigation system to accommodate the staking. Additions and deletions to the bid quantities will be made using unit prices.

M) Staking and Layout (if needed)

The installer must provide four experienced crewmembers for the purpose of staking the locations of all irrigation equipment and appurtenances when requested. All staking will be done at the direction of the owner's representative in conjunction with the golf course Superintendent. Furnish a 300-foot fiberglass tape and new, 18" tall, colored wire flags to mark head locations. Flags must be a different than any others used for golf course construction.

The plans and these specifications will be used as a guide in selecting the final locations for head placement. The Owner's Rep. will stake all head locations in conjunction with the Owner and the Contractor. Install heads within one foot of the stake. If for any reason it is necessary to locate a head more than a foot from a stake, inform the Owner in writing and obtain his approval prior to installation.

Immediately after sprinkler locations are set, draw an as staked plan of each hole. Include all sprinkler and quick coupler locations relative to golf course features. As staked plan shall note the sprinkler type, spacing, staked quantities and net differences by hole. Provide copies of all as staked drawings to the owner's representative as soon as they are available.

Maintain flags/stakes, until all installation of sprinklers and quick couplers is complete.

N) Wire Routing and Size

Wire sizing shall be in accordance with the Plan and these specifications only, no substitutes.

Routing of the wire shall be in accordance with the plans except that the Owner's Representative reserves the right to change the routing from that shown on the plans and to change the depth of trench and cover over the top of wire in case of rock or other obstacles. In no event shall field changes of this nature affect the overall cost of the project, except where these changes may alter the quantity of materials to be provided according to the plans or where excess depth of trench and backfill is required.

Do not route any wire through the sand area of bunkers, the putting surfaces of greens, or the tops of tees. The Contractor, subject to approval of the Owner, may adjust the location of any pipeline to avoid trees, rock outcrops or other obstacles provided that such adjustment is not in conflict with the evident intent of the plans or these specifications.

O) Record Drawing-General

Whereas the Irrigation Plans are furnished by the Supplier to provide a guide for the staking and installation of the system, the Record Drawing is furnished by the Contractor to provide an accurate record of the actual location of all the installed and existing to remain system components. The base map for the As Built shall include all features and irrigation elements for the entire area under construction. This includes all fairway, bunker, tee and green outlines, tree lines, water bodies, bridges, building outlines, roads and other significant features.

The as-built for the irrigation system must include all sprinklers (existing and proposed), including spray heads, quick couplers, electric valves, isolation valves, drain valves, pond fill valves, air release valves, all piping, tees, directional fittings, and reducers. The electrical as-built shall include all stations (including sprinklers and electric valves), controllers, splices, telephone cables, communication cable, power wire and sizes, location of all spare 24 volt wires. Include satellite and control station numbering in accordance with sequence specified by Owner.

The Record Drawing is considered as essential as any other component of the irrigation system. Approval for payment is predicated on the submission of the updated Record Drawing to the Owner's Representative keep the Record Drawing current on a weekly basis and always available to the Owner and the irrigation designer at the site.

P) Record Drawing-Details

The Contractor shall be responsible for keeping accurate information of the Golf irrigation system during the installation of the project. The Contractor shall maintain a record copy of all changes and additions in the Superintendent's office during this construction phase.

The final record drawing shall be produced through the use of GPS Global Positioning System equipment that meets or exceeds the following standards:

Data gathering shall be by differential GPS measurement and verified by post processing and accuracy must be within one foot.

Employ differential correction processing from Omni-STAR or from a base station located on site that collects data at one-second intervals. Use of offsite community type base stations not under direct control of contractor is not acceptable.

Export GPS data into appropriate State Plane coordinate system and import it in to an AutoCAD drawing. Structure CAD drawing so that each element has its own separate layer. AutoCAD blocks shall be used for all irrigation elements. Symbols and block names must be consistent with irrigation industry standards and naming conventions and approved by the Consultant. All as-built and base

data shall be collected and presented in a fashion that is compatible with Rain Bird Central Software. Import areas as polylines, not splines.

When the Owner and the Consultant have approved final record drawings, provide the following to the Owner:

- 2 color plots of each sheet in Record Drawing at 1"= 100'.
- 1 laminated color plot of each sheet at 1" = 100'.
- 2 sets of laminated copies of each hole plotted on 8 1/2 x 14" paper.

In addition, provide the following to both the Owner and the Rain Bird factory certified programmer. Contractor is fully responsible for all costs incurred for importing map image on Central Controller and linking all data points to the data base in order to create a final working image on the Central.

One CD containing Final approved record drawing prior to map conversion in AutoCAD .dwg and .dxf formats and Final approved record drawing and map conversion in AutoCAD .dwg and .dxf formats.

Q) Inspections

The Owner's Representative shall be afforded access to make whatever inspections are necessary. Provide whatever labor and maintain and operate whatever equipment may be required to properly test or inspect the work. The progress of the work shall not interfere with the Owner's right to inspect. Inspection shall not constitute acceptance. Subsequent to inspection and prior to final acceptance, any work or materials found by the Irrigation consultant or the Owner to be not as specified shall be removed and properly replaced by the Contractor at his own cost.

R) Final Inspection and Testing

At least ten days prior to scheduled date of final inspection of the complete irrigation system, submit to the Owner's Representative for his approval a complete and correct copy of the preliminary Record Drawing and three copies of manufacturer's maintenance and operation instructions for all components installed. Test the system in accordance with these specifications. At the completion of the work, the Irrigation consultant will inspect the system to insure that all equipment is fully operable and that the system complies with the plans and specifications. The Consultant shall assist the Owner in preparing a final punch list that is to be furnished to the Contractor for completion prior to satisfying his/her contract.

S) Guarantee

The following is added to the requirements of the General Specifications:

The Contractor is responsible for the immediate repair of any system malfunction or defect (due to faulty materials or workmanship) that may appear during that period. If an equipment manufacturer's warranty continues for a longer period, that warranty shall extend to the Owner as well.

T) Operating Schedule

The system is designed to irrigate the entire course each night, and to apply 1.5" (gross) per week in less than 8 hours of daily operation. Components are sized to operate any combination of stations up to the capacity of the water source, as long as the stations are spread reasonably throughout the distribution network and flow management zones are programmed to limit velocity to 5 feet per second or less. Operating other combinations could result in reduced performance or possible damage to components.

U) Pump Station Winterization, Spring Start-up, and Trench Leveling

The Contractor must blow out and winterize the new pump station, when directed by the Owner, in the fall of the first year of operation following acceptance of the system. Fill and pressurize the system, when directed by the Owner, in the Spring after the first winterization. At this time, reset and level any trenches which may have settled and return to the proper grade, and repair and replace with new sod if required, and level any new valve boxes which have settled.

V) Existing Pipe and Utilities, etc.

The locations of utilities on the plans are approximate only. The Contractor shall be responsible for field location and marking of utilities. Call One Call or equivalent utility locating service prior to any excavation. The Contractor shall immediately notify the Owner if utilities not shown on the plans are found during excavation. At points where new installation work crosses utilities, or connects to existing irrigation pipe to remain; the Contractor must dig by hand to locate them prior to machine trenching. Repair all such lines damaged in the course of the installation. The Contractor shall pay for repair of all damage to utilities or existing irrigation to remain caused by his employees or subcontractors.

W) Insurance

Refer to General Specifications.

2.0 MATERIALS

A) General Material Specifications

Except for the existing Watertronics Pump Control Panel being salvaged and re-used, all materials shall be as specified, and shall be new and unused. Any equipment or materials found to be defective or not as specified shall be removed and proper materials shall be installed as ordered by the Owner. The local factory authorized large turf distributor servicing the region shall provide all Rain Bird and Watertronics components and allied materials. It is required that only one supplier be utilized for supply of the complete irrigation package, this allows the Owner to contact one representative for all product warranty and service issues. The Owner's Representative shall decide on the acceptability of any and all materials submitted for installation in the system. No deviations from these specifications will be allowed. Promptly remove equipment or materials found to be defective, damaged or not as specified.

B) Storage

Machinery and material storage shall be confined within the areas so designated by the Owner. The Contractor shall be solely responsible for all machinery and materials stored on the site. All pipe must be stored off the ground and care shall be taken to keep the pipe clean (inside and outside) and free of debris. The Contractor, at his own expense, shall provide security of machinery and materials on site.

C), D) & E) n/a

F) Reachwells, Valve Boxes

Access to 14/1 & 12/1 field wire and 110V power wire splices shall be provided by Carson model 1419 standard boxes with green T-top cover and standard 6" extensions if needed.

All communication wire (14/2 Maxi) splices not associated with VIH units shall be housed in a Carson model 910 10" round box with GRAY electrical lid and locking mechanism. Each gate valve shall be housed in its own valve box.

G) Wire, Splice Kits

Only MAXI Wire, Paige model P7072D 14/2 gauge, or equal, will be accepted for use in repair, if required, of existing Rain Bird communication wire path. Sizes will be as indicated on plans. Jacket Colors must be specific to existing wire path.

Use 14/2 gauge wire where wire paths follow main or lateral piping. Insulation shall be Polyethylene. PE insulated wire shall be UL listed, suitable for direct burial, and rated for operation up to 600 volts. PE insulated wire shall be used for 24V wiring only. 110 V power wire for new controller shall be #10/3 Tray Cable with PVC insulated jacket, Paige model P7627D.

All Valve and Sprinkler wire must be Paige model P7079D 14/1 and 12/1 wire PE Insulated copper wire. Jacket colors will be chosen to match existing field wire colors.

Splice kits shall be 3M DBR/Y units for ALL sprinkler and valve splices. Where Maxi wire three way splices are necessary, use a 3M Scotch-lok connector installed in a 270323 Scotch-cast Resin Pack, all housed in its own Carson 1419 standard valve box with T-top lid.

H), I), J), & K) n/a

L) Rain Bird Controller

The New Irrigation Controller to be installed on hole #18 shall be a Rain Bird model PAR+ES722S, 72 Station Controller with Two Wire Modem. No alternates will be accepted, this controller is the only compatible model currently available with the Course's existing Rain Bird Satellite Control system.

M) Surge Arrestor

An Intermatic model AG2401C3 w/LED indication shall be furnished and installed per manufacturer's recommendations in the new Rain Bird Controller.

N) Grounding

Grounding for the new Controller shall be as follows: one each 5/8" x 10 foot Copper Clad Ground Rod, one each 4" x 96" Copper Ground Plate with 25 feet of insulated #6/1 wire, 2 50lb bags of Powerset Ground Enhancement Material, Loose 6/1 Bare Copper Connected to ground rod with a Cadweld #GT1161G Exothermic Weld Connector. All items are as distributed via Paige Electric, Union, NJ, via the Authorized Rain Bird Golf Distributor.

O) Pump Station

It is the intention of this specification to describe an automatic, prefabricated pump station. Design, fabrication, testing and service shall be the sole responsibility of the pump station manufacturer. The pump station shall provide water to the system while simultaneously maintaining a constant discharge pressure by using a prefabricated pump station pump for pressure regulation, under varying flow conditions up to the maximum specified capacity.

3.0 PUMP STATION

A) General

1. The prefabricated pump station shall have a minimum capacity and discharge pressure at skid edge as described in the technical specifications. The overall pump length shall extend to within twelve inches of the bottom of the wet well. The main pumps shall operate at no more than 1800 RPM.
2. The station shall be completely wired, piped, hydraulically, electrically, and flow tested to full station capacity at factory prior to shipment to job site. Documentation of dynamic test shall be verified by owner prior to pump station shipment.
3. Construction shall include a fabricated steel plate and skid assembly to support all components during shipping and to serve as the installation mounting base.
4. The discharge manifold from the pump station shall terminate at or near the pump station skid edge and be provided by the pump station manufacturer.

The pumping station shall be model number VT as manufactured by WATERTRONICS, INC. 525 Industrial Drive, P.O. Box 530, Hartland, Wisconsin 53029-0530, www.watertronics.com

B) Manufacturer Requirements

1. Manufacturer: The pump station shall be manufactured by **Watertronics, Inc.**, Hartland, Wisconsin. The following information must be furnished by the contractor or manufacturer's representative within 10 days before bid date, to the Consultant/Engineer for consideration as an equal brand.
 - a. A complete specification and submittal of all major components for the proposed pump station with individual pump performance verification.
 - b. A detailed pumping station proposal drawing complete with component location, sizes and dimensions specific to the installation and matching the specifications herein.
 - c. A complete electrical schematic for all high and low voltage circuits showing breaker/ fuse sizing, wire numbering and color.
 - d. Pump station manufacturers U.L. file number for the electrical controls and pump station.

- e. A copy of the manufacturer's certificate of insurance in excess of \$1,000,000.
- f. Product support technicians shall be capable of accessing all information pertaining to the pumping equipment, e.g. electrical schematics, pump curves, program data, bill of materials, etc. The manufacturer shall have no less than two technicians on call seven days a week. Verify with Names, Addresses, and Phone Numbers.
- g. The pump station manufacturer shall provide factory authorized or factory direct service personnel for the set, start-up, preventative maintenance and general service of the pump system. A factory authorized or factory direct service technician must be located within one-hundred (100) mile radius of the project site. The pump systems technician must have a minimum of 5 years' experience. The pump station manufacturer shall provide technical phone support twenty-four hours a day seven days a week. Verify with Names, Addresses, and Phone Numbers.

C) Pump Assemblies

1. Vertical Turbine Irrigation Pump

Bowl assembly including suction case, intermediate bowls and discharge bowls shall be of Class 30 cast iron. The impellers shall be of **stainless steel**, statically balanced. Impellers shall be adjusted vertically by means of an adjusting nut located at the top of the driver. Each pump shaft is to be turned, ground and polished stainless steel having a chromium content of not less than 12%. It shall be supported by bearings above and below each impeller. The size of each shaft shall be appropriate to transmit the horsepower required by the pump.

Each turbine pump inlet strainer shall be corrosive resistant basket type with an area not less than four times the pump suction bell inlet area.

The discharge column pipe shall be A53 Grade B schedule 40 and furnished in interchangeable 10' sections with threaded couplings. The line shafts shall be ground and polished 416 stainless steel, and shall be coupled with steel couplings, have left hand threads, which tighten during operation. Drop-in type shaft centering spiders shall be provided at each column coupling at maximum 10' spacing. The section of shaft passing through the stuffing box shall be stainless steel having a chromium content of not less than 12%.

2. Discharge Head

Each pump shall be supplied with a DUCTILE IRON discharge head having a flanged discharge opening. The top diameter of the discharge head shall match the motor base to distribute the load uniformly. The minimum operating pressure of each discharge head shall be no less than 30% higher than the maximum output pressure of the pump. The DUCTILE IRON discharge head will have a tensile strength of 65,000 PSI.

3. Mechanical Seal

Each turbine pump discharge head shall contain a mechanical seal assembly located where the line shaft protrudes through the discharge head. The mechanical seal assembly shall consist of a main housing, shaft sleeve assembly, locking and drive collars. The shaft sleeve shall be machined from 416 stainless steel. The locking and driving collars shall be machined from 7075 aluminum. Integral to the seal housing, a permanently lubricated ball bearing shall be mounted, located out of the pumping media. The mechanical seal shall be resistant to corrosion and abrasives, totally self-lubricating, and rated for no less than 300 PSI. The seal assembly shall require no bypass tubes or related devices to provide cooling or lubrication.

4. Column Pipe

Column pipe should be A53, Grade B schedule 40 material, in inter-changeable sections not more than 10 feet in length. Pump line shaft shall be AISI 416 SS. The size of the shaft shall be no less than determined by ANSI specification B58.1, Section 4.2, Table 4. Bearing retainers shall be bronze with rubber bearings.

5. Submersible Pressure Maintenance Pump

For the purpose of maintaining system pressure during non-irrigation periods, a pressure maintenance pump shall be incorporated in the system. Pressure maintenance pump shall be submersible type, constructed of stainless steel. The pressure maintenance pump shall perform as specified by the Technical Specifications.

D) Motors

1. Pressure Maintenance Pump Motor

The system pressure maintenance pump shall be equipped with a 3600 RPM, high efficiency submersible motor. The pressure maintenance pump shall perform as specified by the Technical Specifications.

E) Skid, Piping, Valves, Gauges, & Mechanical Equipment

1. Skid Construction

Pump station skid shall be formed from a single sheet of 3/8" steel, continuous welded and smooth ground at all corners resulting in a seamless, one piece structure with rounded edges and corners. Two 3" holes shall be located at each corner of the skid, on the side wall, for the purpose of lifting the pump station. The skid shall be strategically reinforced underneath with structural channel iron to support pumps, manifolds, control enclosures and periphery. The skid shall be drilled and tapped for mounting of pumps, manifolds, tanks, relief valves and other equipment. All tolerances shall be sufficient to permit direct bolting of pump station components to skid. No slotted holes shall be permitted in the pump station skid and no nuts or bolt heads shall be permitted on the underside of the skid. The pump station skid shall cover the wet well completely, without the need for a separate wet well cover plate. The pump station skid shall incorporate an integral wet well access hatch measuring not less than 16 inches by 24 inches. The access hatch door shall be both hinged and removable. For safety purposes, the wet well hatch access handle shall not protrude above the skid surface. The skid shall be primed and painted per enclosed specification on both top and bottom.

2. Fabricated Piping

All fabricated piping shall conform to ASTM specifications A53 for Grade B welded or seamless pipe. Discharge piping 8" and above shall be a minimum of Schedule 10. Discharge piping 6" and smaller shall be Schedule 40. All welded flanges shall be forged steel slip-on or weld neck type. All welded fittings shall be seamless, conforming to ASTM Specification A234, with pressure rating not less than 150 psi.

3. Drains

Drains are to be provided from any possible low point in the system and are to be equipped with 3/8" A or 1/4" brass valves. Drains shall include, but are not limited to, the following:

- Drain for each pump discharge check valve
- Drain in discharge manifold upstream of station discharge isolation valve.
- A wash down 3/4" brass hose bib on the discharge manifold, upstream of the main station isolation valve.

4. Pump Check Valve

Pump check valves shall be bolted directly to the pump discharge heads and sized per the technical data sheet. They shall be of the silent operating type that begins to close as forward velocity diminishes and be fully closed at zero velocity preventing flow reversal. Valve bodies shall be cast from ASTM-126C cast-iron or better and shall be free from blow holes, sand holes, and other impurities. The valve design shall incorporate a center guided, spring loaded poppet, guided at opposite ends and having a short linear stroke that generates a flow area equal to the pipe diameter. Internals shall be machined bronze disc, seat, and stem guide. Valves shall be sized to permit full pump capacity to discharge through them without exceeding a pressure drop of 2.5 PSI. Valves 4" and smaller to be pressure rated for 250 PSI, 6" to 10" to be pressure rated to 150 PSI. Valves 12" and larger check valves to be globe style with 150 PSI rating iron bodied with bronze trim.

5. Isolation Valve

Each pump shall be isolated by means of a butterfly valve after the check valve and before the discharge manifold. The discharge manifold shall also have an isolation valve at the skid edge. Isolation valves shall be butterfly type with ten position lever for valves 4" and smaller or gear operators for valves 5" and larger, rated for 200 PSI WOG working pressure. Trim shall include stainless steel stem, bronze or nickel coated iron streamlined disk with full faced resilient seat design to eliminate need for flange gaskets.

6. Pressure Relief Valve

A pressure relief valve shall be installed on the discharge piping downstream of the pressure regulating valves. The valve shall be sized to bypass sufficient water back to the water source to avoid the discharge pressure from exceeding the maximum programmed pressure set point by more than 10 PSI.

7. System Air Release

Individual pump column air shall be purged prior to entering the pump station discharge manifold. An air release assembly shall be located on each pump discharge head, upstream of the pump check valve. Separation reservoirs or tanks with air/ water balance controls shall not be accepted.

8. Pressure Gauge

A pressure gauge shall be located on the discharge manifold for the purpose of measuring regulated, downstream pressure. Pressure gauge shall be 304 stainless steel case and bezel construction. Gauge shall be 4" diameter, liquid filled. Pressure sensing connection shall be 1/4" NPT lower gauge connection.

F) Additional Skid Mounted and Control Integrated Equipment

1. Lake Level Controls

The irrigation reservoir shall be continuously monitored by an electronic pressure transducer, which will send a 4-20ma signal to the PLC. The reservoir level will be read on the Touchscreen operator interface and displayed in inches. The user shall be able to control the remote signal activation level by making the desired adjustments on the screen. When low (set point) level has been maintained for the pre-set period of time, a 120 VAC signal shall be sent to a dry contact relay in the pump station panel to activate the start signal for a fill pump or valve. Upon a rise in the reservoir level the signal will stop and the relay will drop out to stop the filling operation. Lake level wire terminal connections will be located in a J-box on the control panel exterior.

2. Flow Sensor

A flow sensor shall be installed providing the pump station flow rate and total flow through the operator interface device (OID) as specified in section (3.11). The flow sensor shall be a six bladed design, which provides a low impedance signal proportional to the flow. The accuracy shall be plus/minus 2% of actual flow rate between flow velocities of 1-30 ft./sec. A flow meter run shall be included with a minimum of 5 pipe diameters straight run upstream and 2.5 pipe diameters downstream for proper meter accuracy. Flow sensor model must have internal noise filtering feature. Flow sensor wire must be encased in 1½" liquid tight conduit from sensor to enclosure. Meter run shall be sized as shown in technical data sheet.

G) Construction

Construction shall be of modular form utilizing a steel base structurally adequate to support pumps, piping, tanks, and electrical equipment as a single integral assembly. All nuts, bolts, washers, and fasteners shall be zinc or cadmium plated for corrosion resistance.

H) Painting

Painting of the entire unit shall consist of a multi-step coating system including metal preparation, a rust prohibitive epoxy prime coat and a two part ultraviolet insensitive polyurethane finish having a total dry film thickness of not less than 5 mils. Each coat will be applied and baked for one half hour at 165 degrees F. All pump station components including skid, manifolds, isolation and relief valves, grooved clamps and supports shall be painted medium green. All electrical enclosures and accessory panels and tanks shall be appliance white.

I) Testing

The pump station manufacturer shall conduct and document a complete factory dynamic test of the pump station prior to shipment. Pump station shall be tested throughout the entire operating range at the net discharge pressure called for in the technical specifications. Individual pump pressure, flow, RPMs, volts, amps, KW and power factor shall be documented for verification by the consulting engineer or owners' representative prior to delivery upon request.

J) On-Site Pump Station Off Loading & Setting

Specifically called out elsewhere in the specification. Crane to off-load and set the pump station on the concrete slab is to be provided by contractor.

K) On-Site Pump Station Start Up

1. Technical start up shall be furnished by the pump station manufacturer or a qualified, Watertronics certified service agency. Location and mounting details shall be furnished by the pump station manufacturer. Electrical connection, by purchaser, shall consist of a single conduit from owners disconnect to the pump station main disconnect. Additional purchaser responsibility shall include confirming correct motor rotation and securing local inspection/approval.

2. Technical start up procedures by the pump station technician shall include the following:

- a. Station start up and pressurization.
- b. Pressure, flow and programming adjustments.
- c. Monitoring of complete operational cycle when possible.
- d. Customer training and presentation of owner's manual.

L) Warranty

The manufacturer shall warrant the pumping station to be free of defects and product malfunctions for a period of two year from date of start-up or twenty-seven months after shipment, whichever occurs first. Failures caused by, lightning strikes, power surges, vandalism, flooding, operator abuse, or acts of God are excluded from warranty coverage. All warranties implied or otherwise shall not exceed those warranties extended by major or sub-component suppliers.

M) Site Preparation Drawings

Site preparation drawings shall be furnished by the manufacturer within two weeks after receipt of order. Drawings shall indicate pump station alignment, discharge piping size, and electrical services required from local contractor. The owner shall return one set of drawings marked approved or corrected within one week of receipt.

N) Operation and Maintenance Manual

Operation and maintenance manuals shall be furnished at time of startup and initial training. Owner will also receive training specific to this station as specified.

O) Installation

1. General Installation Specifications

Install pump skid, wire, splices, controller components and all other appurtenances in strict accordance with the manufacturer's recommended procedures, standard industry practices, construction details, these specifications and the directions of the Owner's Rep. in the field.

2. Excavation

No trenching whatsoever shall occur on or under greens. All mainline piping shall be trenched. Vibratory plowing of solvent weld pipe for laterals is acceptable where soil affords proper depth of plowing.

Excavate the trench only wide enough to allow for proper tamping around the pipe in accordance with the manufacturer's recommendations. Excavate the trench deep enough to allow a minimum of 18" of cover over the wire for laterals and 24" for wire following mains. Power wire must have a minimum of 24" cover. Ensure that the bottom of the trench is clean and smooth with all rock, loose soil and organic matter removed, and that there are no conditions in the trench that could damage the pipe or wires. Any deviation from the above must be reviewed and approved by the Owner's Representative prior to installation.

3. Deleterious Material

Excavated material, which consists of rock larger than 2" in diameter, or other material unsuitable for backfill (as defined by the pipe manufacturer's installation instructions) is classified as deleterious material. Remove this material and haul it to an on-site dump location designated by the Owner. In backfilling excavations where deleterious material has been removed, install select backfill. Select Fill shall be clean, granular mineral soil suitable for growing healthy turf. Select Fill must be inspected and approved by the owner's representative prior to delivery. There is no rock clause for this project, please figure your bid accordingly.

4. Blasting

If subsurface conditions along the proposed trench line are such that excavating equipment of the type and size correctly suited to this installation cannot properly excavate the trench and blasting is required, the Contractor shall do so only after obtaining the written approval of the Owner. Store and use explosives as prescribed by state and local laws, and obtain all required permits. Pay all fees, and conform to all regulations pertaining to blasting operations.

Employ only experienced personnel. Provide protection for all persons on the Owner's property and on adjacent property. The Contractor shall be responsible for any personal or property damage resulting from this work. Remove and dispose of, on site, all excess and other material unsuitable for backfill as directed by the Owner's Representative. Payment for blasting shall be based on a cubic yard measurement at a price to be stated in the bid form.

5. Pipe and Fittings

All pipe must be stored off of the ground and care shall be taken to keep the pipe clean and free of debris. The owner and the irrigation consultant reserve the right to reject any PVC pipe that is not stored or handled properly, and that may be damaged or contaminated.

The contractor will replace any rejected piping installed at no additional cost. Store PVC pipe, fittings and gaskets such that they are protected from oil and grease and from prolonged exposure to sunlight and excessive heat.

Make all field cuts and bevels to manufacturer's specifications. Make solvent weld joints in strict accordance with manufacturer's recommendations and ASTM Standards D2564 and D2855, especially as they apply to ambient temperatures. Solvent and primer must be of a type approved by the manufacturer of the pipe and fittings. Do not lay pipe in a trench that contains standing water. Cap, tape or plug all openings in installed pipe until they are closed by the fitting or pipe that connects at that point. Prior to initial operation of sprinkler heads, thoroughly flush all pipe through drain valves or quick coupling valves to remove all pipe shavings, dirt and pebbles which may have entered during pipe installation. Pipe sizes are shown on the plan.

Where proposed gasket joint piping is required to connect to existing piping use only ductile iron bell x bell couplers. Where existing solvent weld piping is required to connect to proposed solvent weld piping use only solvent weld couplers. No compression couplers or Flo-span couplers will be allowed in the final installation.

If two pipes of any size cross, there must be a minimum of 4" of separation using clean compacted earth.

At locations of all buried fittings install wood lath stakes identifying the type of fitting and size. These stakes shall remain until all GPS data collection is complete.

6. Valves

Install isolation valves plumb and level, and anchor them with the appropriate joint restraints as required. All valves shall be housed in proper valve box with PVC sleeve.

7. Thrusting

Install thrust blocks or anchoring for all isolation valves larger than 2½" and all gasketed piping including reducers and changes in direction, in strict accordance with the pipe manufacturer's recommendations for the soil and pressure conditions on this site and ASAE spec. # S376.2. Construct thrust blocks of Sakrete or pre-mixed concrete of the following mix having a compressive strength of 2000 PSI or more:

- 1 part cement
- 2½ parts sand
- 5 parts washed gravel
- Water

The area of the bearing surface of the thrust block shall meet the pipe manufacturer's recommendations based on the fitting, pressure and soil involved.

Do not put concrete on top of pipe, wire, valves, or fittings. All thrust blocks must bear against undisturbed soil. If undisturbed soil is not available due to excessive earthwork (i.e. pushed up greens) use Harco joint restraints according to manufacturer's recommendations.

8. Wire

Do not stretch, or excessively pull wire during installation. Provide a minimum of one foot of slack, in an expansion coil, in each 100 feet of wire. Lay wire on a firm even bed in the trench that shall support the entire length. At wire splice locations provide sufficient slack to allow the splice to be raised a minimum of 24" above grade for inspection. Take strict precautions to ensure that wires are not cut, scraped or nicked during installation. Do not lay wire above, or on top of the pipe. All wire shall be installed in the bottom of the trench. Where multiple wires exist in the same trench, Bundle all like wires every 20 feet using black UL electrical tape.

Install all power wire runs in the mainline trenches and locate them accurately on the record drawings. .

Anywhere wiring will be run above grade (on building walls, on mounting posts, bridges, etc.) it must be protected in approved PVC gray schedule 40 UL listed sweeps and conduit. If a change of direction is required on these runs, make it as an angle between two straight runs, and not as a sweeping curve. Install a reach well at the angle point and leave sufficient slack in all wires to allow them to be raised at least 24" above grade.

Accurately locate the reach wells with measurements on the Record Drawing. 2" gray Schedule 40 PVC electrical conduits will be installed for power wire at all road and stream crossing locations. Should wire need to be installed under pavement or at bridge crossings, install it in 2" gray Schedule 40 PVC electrical conduit as well. Install all wiring inside buildings in accordance with NEC and local codes.

Wire shall be properly stored at the job site and should not be exposed to sunlight for more than a three day stretch. The golf course representative shall be responsible for the security of the wire and ensure wire is properly protected from the weather element. The golf course will be responsible for replacement if wire is damaged or stolen.

All Communication cable shall be buried at the same depth and in the same trench (where applicable) as the PVC pipe with a minimum cover of 18". Communication wire that is plowed in shall be installed at a minimum depth of 18".

All Field Communication Wire for the Rain Bird Sprinklers shall be 14/1 single conductor insulated with a high quality polyethylene (PE) jacket. Use only 12/1 gauge wire for common.

At changes in direction in the mainline routing, the wire should have a loop or coil that is 36" in length to allow for thermal expansion and contraction.

At locations where future wire connections will be made, typically where lateral isolation valves or splices will be installed, allow a 36" loop of wire. This should be done in a manner that allows sufficient extra wire to lift the wire splice at least 24" above final grade to allow for future service access.

When the communication cable is being installed using a vibratory plow, the wire sleeve on the plow must be of sufficient size to prevent damage to the outer jacket. The wire shall be "laid" and must never be literally "pulled" in. In addition, proper use of the vibratory plow so that stretching of wire does not occur.

All splices in the communication path must be placed in a 10" round valve box w Grey electric lid, to facilitate future troubleshooting. All three-way and four-way splices must have sufficient slack to lift the splice 24" above grade for ease of access. Where possible, valve boxes should be avoided in high profile areas like fairways. All splice locations must be recorded on construction 'as-built' plans so they may be located in the future.

All wires in a valve box should be permanently identified with a permanent marking pen on a suitable permanent tag to identify where the wire is coming from and where it is going.

It is very important the communication cable is properly installed so that the copper conductors are not damaged or exposed after installation. The outer communication cable jacket shall be removed by use of a King UF Safety Stripper. Tools such as utility, pocket, carpet, and box cutter knives should not be used nor should Romex Strippers.

All wires splices shall be made by use of a 3M DBR/Y-6 splice kit to ensure waterproof splices. Do not use tape of any sort to hold wires and splices to the rotor body. Locate all splices under the selector assembly on the rotor so that they can be easily identified in the future.

9. Wire Splicing

Splice all wires to requirements of local minimum regulations or to the following specifications, whichever is more restrictive. Crimp sleeves; wire nuts, or brass service clamps are acceptable in lieu of soldering. Make the splice completely waterproof using connector kits in strict accordance with manufacturer's recommendations, especially concerning ambient temperatures during installation. Install only one splice in a connector kit. House all splices not located at VIH sprinklers or field controller sites in a Carson Gray "electrical" valve box (10" round w/ T-top lid) and accurately locate them on the Record Drawing. Leave sufficient slack in all wires at all splices so they can be raised at least 24" above grade. Power wire and communication cables shall be laid in continuous runs without splices, except at connection points, and these splices shall be made in controller enclosures where possible.

Install a DBR/Y kit on the end of any spare wires and locate in nearest valve box, and accurately locate the end of each spare wire on the Record Drawing. Install Maxi Cable Communication splices in 3M Watertight Gel Packs. Use 3M 82-A style splice kits with gel packs on power wire splices.

10. Reachwells, Valve Boxes

Support all reachwells and boxes on bricks or concrete blocks and properly notch or "saddle" them so they will not damage pipe or wire if they are pushed down.

Install reachwells and valve boxes flush with finish grade and on level, dry ground. Do not locate them in green approaches, collars or putting surfaces, or on the tops or slopes of tees. Communication Splices not associated with VIH units or field controllers shall be housed in Carson Gray 10" round "electrical" box with cover. Power and field wire splice locations shall be installed in Carson 1419 Standard Boxes. A minimum of 18 inches clearance shall exist between top of all wire runs and valve box lids. All valve box lids shall fit tightly and snug. Inside of all valve box enclosures shall be lined with 3" of washed pea gravel.

11. Backfill

Backfill trenches using excavated material with a maximum size of 2". No rocks, frozen earth or other unsuitable material (as defined by the pipe manufacturer's installation instructions), which could damage the pipe or wires are permitted. Cover pipe to a depth of 6" inches before any machine backfilling or tamping is used. In filling around pipe, keep materials on both sides at equal height and tamp with the same thoroughness. Compact the backfill with a trench compactor, or a rammer (or equal), to eliminate voids and future settling and to bring the settled trench line flush with surrounding grade. The goal is to achieve the same compaction as exists in the adjacent undisturbed soil. Do not compact excessively.

If insufficient quantities of acceptable backfill are generated from trench excavation, use select backfill to bed the pipe (4" below pipe) and cover it to a depth of 6", before installing any other backfill material. Fill the remainder of the trench with excavated material. Payment for supply and installation of select backfill shall be included in the deleterious material item on the Bid Proposal. Remove and dispose of all excess or unsuitable material on site as directed by the Owner's Representative.

12. Bridge, Road and Stream Crossings (If Necessary)

Attach SCH40 PVC UL listed gray conduit securely to the bridges using approved neoprene coated steel pipe U shaped hangers. Bearing surface must be at least 2" wide. Hangers must be placed at least 5 feet apart, and must support the weight of the pipe full of water without allowing any lateral or longitudinal movement or sagging. Pipe attachment procedure and location must be acceptable to the Owner. Transition of HDPE to PVC will be accomplished using HDPE and Ductile Iron Flange Adapters, Backing Rings, joint restraints, and hardware for 150 psi rated Flange Connections.

Ensure that fittings installed to make the vertical bends up to the bridge are properly thrust or restrained in accordance with pipe manufacturer's recommendations. Install 2" solvent weld gray UL listed PVC electrical conduit parallel to pipe as a conduit for wiring, and seal the ends with Duct Seal. Power and communication cable cannot share a common conduit.

13. Road Crossings (If Necessary)

Install wire in a 2" SCH 40 UL Listed solvent weld gray PVC conduit at all road crossings. Seal the ends of the conduit with Duct Seal. Sleeves and conduit shall extend 10' past the pavement edge on both sides of the road. Surface of roadway and shoulder to be restored to original condition.

Make road crossings in accordance with local codes and requirements. Secure and pay for all necessary permits. Notify local officials as required.

14. Central Data Entry

New Controller and newly wired existing Valve in Head and Block Zone Valve Station Data must be recorded on detailed Controller Data sheets by the contractor, and provided to the Authorized Rain Bird Factory Rep for addition to the existing Rain Bird Nimbus Central Controller Data Base for automatic operation. Data sheets must be generated for each area immediately upon completion of work in that area so system can be modified for instant automation and watering of newly grassed areas. Cost for this procedure will be the bidder's responsibility and should be covered in your bid.

15. Pump Station

The existing Watertronics Control Panel and two existing 75HP Motors all get removed and stored safely. Panel and Motors must be stored inside, out of weather while removed. The Control panel and motors are being salvaged for re-use on the proposed new pump skid. Prevention of damage during removal, handling, or any damage due weather exposure is the bidder's responsibility. Existing power wire connections shall be carefully removed by a licensed electrician working for the bidder. Care must be taken to maintain all existing wiring intact as it is intended for re-use once panel is re-installed on new skid.

The existing Childers pump skid, submersible pressure maintenance pump and motor, and two turbine pumps will be removed, and disposed of off-site by the bidder. Care must be taken to maintain flange and existing zee pipe as it will be re-used. Any damage to the existing steel zee pipe during removal or installation of the new skid will be the responsibility of the bidder to repair.

Existing wetwell and slab inside pump house are to be maintained and re-used. The new pump skid will be installed as closely to the existing pump station location as is possible (some dimensions vary). The new pumps shall be centered in the existing wetwell. Under no circumstances shall the pumps be no closer than 8" from side of the existing wetwell. Once new skid is set in place it must be inspected by local Factory Authorized Watertronics Pump Technician before anchoring and any connections are made. (These steps are considered

part of the Factory Authorized "Set Assistance" including in the manufacturer's pricing).

New Turbine Pumps are to be set in place and per Factory Authorized Technician, and inspected before existing 75HP motors are re-installed. Once this step is completed satisfactorily, the existing control panel can be installed and re-connected.

Licensed Electrician working for the bidder must reconnect all power to the control panel and check for polarity and phase balance. Once all electric is connected and tested satisfactorily, the station can be initially started by the Factory Authorized Watertronics Pump Technician. Final Startup requires water usage for flow testing and calibration. This step may or may not happen the same time and will be determined by the Golf Course Superintendent allowing water to be applied. If a second visit is required to complete this step it will be the bidder's responsibility to bear all necessary costs. Upon final start up and testing, a copy of the Factory Authorized Watertronics Pump Technician's set and start up reports must be supplied to the Owner's rep as proof that this phase of the project is completed satisfactorily.

All equipment for unloading, transporting on site, installation and removal of the existing skid and pumps, as well as any site clean-up and restoration are the responsibility of the bidder.

16. System Testing

Fill the system slowly, taking care to bleed out all air. Thoroughly flush all mains before operating heads. Cycle all heads and adjust or otherwise correct for any discrepancies that appear. Set the central to run two complete cycles with each head running for 5 minutes. After the two cycles are run, note and correct any head malfunctions. Run a pressure/leakage test as follows:

- A) Ensure that all isolation valves are open, and that all pressure controls and timing relays are properly set to normal operating values.
- B) With no heads operating, observe water meter operation for a period of six hours. If the meters show water usage, the Contractor shall locate the leak(s) and make repairs as necessary. This process shall be repeated until the meters show no usage.

Central and Controller communications and sprinkler operation shall be tested in accordance with controller manufacturer's recommendation. Any failure due to faulty wiring or installation will be corrected at the Contractor's expense.

17. Punch List

The Consultant shall perform a final punch list immediately after the installation is complete. It is the golf course representative's responsibility to schedule a meeting with the contractor to review the final punch list so all outstanding issues can be resolved in a timely manner. Any leaks or failures will be the responsibility of the contractor to remedy or repair while under the warranty period.

END OF SPECIFICATIONS

COUNTY OF UNION, NEW JERSEY
BOARD OF CHOSEN FREEHOLDERS
GALLOPING HILL G.C.
2019 IRRIGATION IMPROVEMENT PROJECT



BOROUGH OF KENILWORTH
UNION COUNTY PROJECT NO. 2019-002
MARCH 2019



LOCATION MAP

GALLOPING HILL GOLF COURSE 2019 IRRIGATION IMPROVEMENT PROJECT	
<small>BOROUGH OF KENILWORTH</small>	<small>COUNTY OF UNION, NJ</small>
TITLE SHEET	
<small>DIVISION OF ENGINEERING COUNTY OF UNION, NJ</small>	
THOMAS O. MNEO, P. E. <small>DIRECTOR OF ENGINEERING</small>	<small>COUNTY ENGINEER N.J. LIC. No. 19646</small>
	DATE: 3/11/19
<small>SHEET 1 OF 4</small>	

LEGEND

SYMBOL	DESCRIPTION
	10/3 TYPE TC POWER CABLE - PATH 2
	14/2 RAIN BIRD MAXI CABLE - PATH 4

PROJECT DESCRIPTION

A. REMOVE EXISTING SATELLITE CONTROLLER. SPLICE INTO EXISTING POWER CABLE AND MAXI CABLE. INSTALL NEW 10/3 TYPE TC POWER CABLE AND NEW RAIN BIRD MAXI CABLE FROM EXISTING LOCATION TO NEW LOCATION. CONSTRUCT NEW CONCRETE PAD WITH SWEEPS. INSTALL NEW SATELLITE CONTROLLER AND HOOK-UP NEW POWER CABLE AND MAXI CABLE. INSTALL NEW GROUNDING. INSTALL ALL NEW SIGNAL AND COMMON WIRES FROM ALL SPRINKLERS, ELECTRIC VALVES AND BUNKER ZONES ON HOLES 10 AND 18 TO NEW SATELLITE.

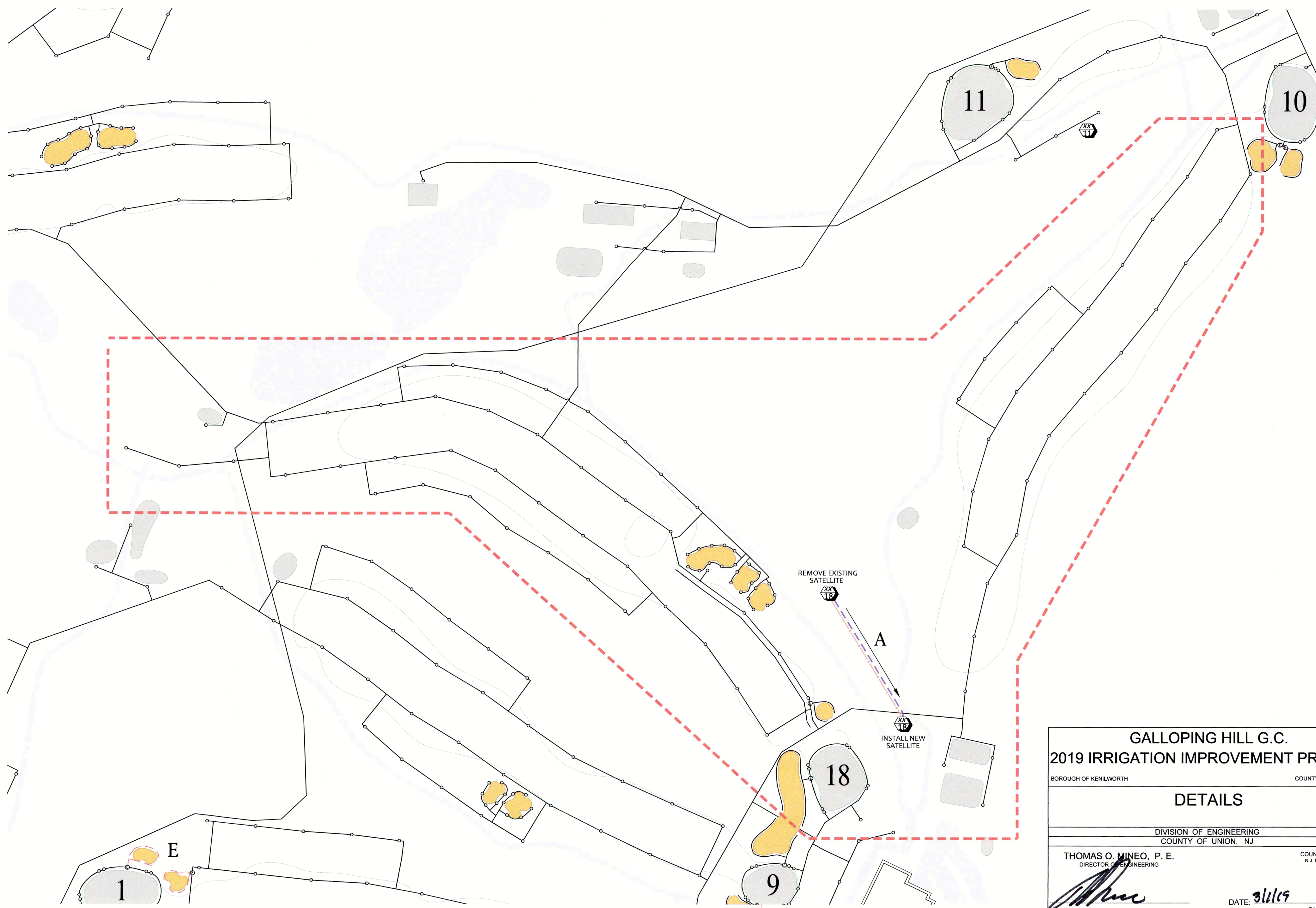



PROJECT:
GALLOPING HILL GOLF COURSE
 KENILWORTH, NEW JERSEY

SHEET DESCRIPTION:
IRRIGATION

GALLOPING HILL G.C.	
2019 IRRIGATION IMPROVEMENT PROJECT	
BOROUGH OF KENILWORTH	COUNTY OF UNION, NJ
DETAILS	
DIVISION OF ENGINEERING COUNTY OF UNION, NJ	
THOMAS O. MINEO, P. E. DIRECTOR OF ENGINEERING	COUNTY ENGINEER N.J. LIC. No. 19648
DATE: 3/1/19	
SHEET 2 OF 4	

JOB NUMBER: GALLOPING - 6 - FALL 2018
START DATE: 10.04.2018
REVISED DATE: 10.11.2018
PRINT DATE: 10.11.2018
SALESMAN: JIM MINER
DESIGN BY: TOM VOGT
SCALE: NOT TO SCALE
SHEET: 2 OF 4

LEGEND

SYMBOL	DESCRIPTION
	10/3 TYPE TC POWER CABLE - PATH 2
	14/2 RAIN BIRD MAXI CABLE - PATH 4

PROJECT DESCRIPTION

A. REMOVE EXISTING SATELLITE CONTROLLER. SPLICE INTO EXISTING POWER CABLE AND MAXI CABLE. INSTALL NEW 10/3 TYPE TC POWER CABLE AND NEW RAIN BIRD MAXI CABLE FROM EXISTING LOCATION TO NEW LOCATION. CONSTRUCT NEW CONCRETE PAD WITH SWEEPS. INSTALL NEW SATELLITE CONTROLLER AND HOOK-UP NEW POWER CABLE AND MAXI CABLE. INSTALL NEW GROUNDING. INSTALL ALL NEW SIGNAL AND COMMON WIRES FROM ALL SPRINKLERS, ELECTRIC VALVES AND BUNKER ZONES ON HOLES 10 AND 18 TO NEW SATELLITE.

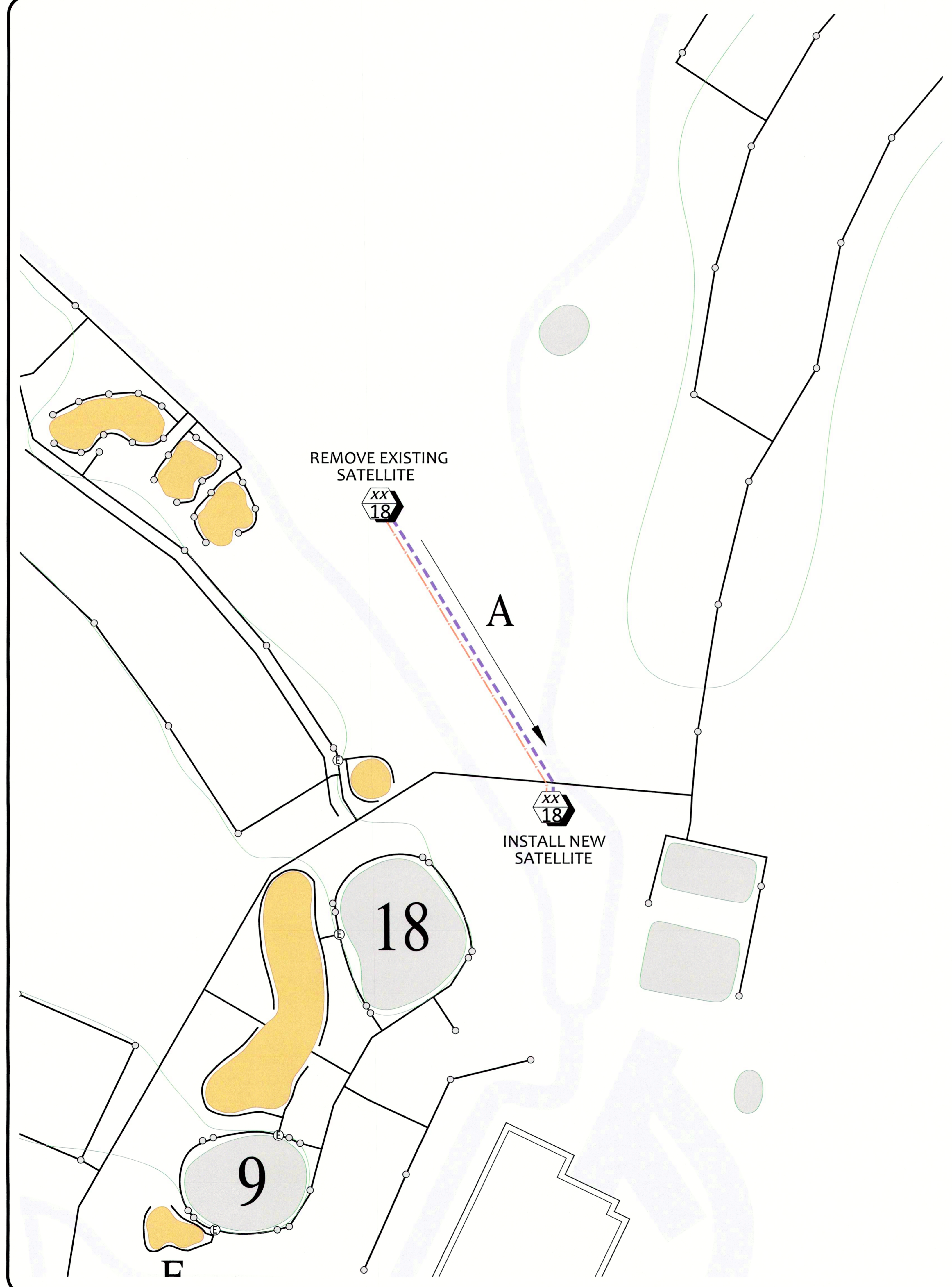

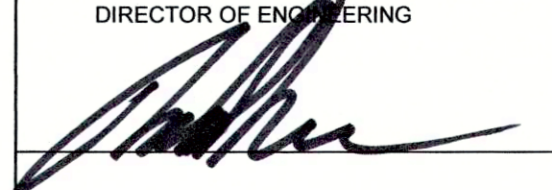
GALLOPING HILL G.C.	
2019 IRRIGATION IMPROVEMENT PROJECT	
<small>BOROUGH OF KENILWORTH</small>	<small>COUNTY OF UNION, NJ</small>
DETAILS	
<small>DIVISION OF ENGINEERING COUNTY OF UNION, NJ</small>	
<small>THOMAS O. MINEO, P. E. DIRECTOR OF ENGINEERING</small>	<small>COUNTY ENGINEER N.J. LIC. No. 19649</small>
	
DATE: 3/1/19	
SHEET 3 OF 4	

<small>JOB NUMBER: GALLOPING - 6 - FALL 2018</small>
<small>START DATE: 10.04.2018</small>
<small>REVISED DATE: 10.11.2018</small>
<small>PRINT DATE: 10.11.2018</small>
<small>SALESMAN: JIM MINER</small>
<small>DESIGN BY: TOM VOGT</small>
<small>SCALE: 1" = 100'</small>
<small>SHEET: 3 OF 4</small>

PUMP STATION SPECIFICATIONS:
 NAME: GALLOPING HILL GOLF COURSE
 STATION MODEL:
 VTV-(1)-75X2/5HPST-480-3-1500-115
 STATION TOTAL PERFORMANCE:
 1500 GPM @ 115 PSI
 PUMP HORSEPOWER:
 SUSTAIN PUMP: 5HP
 PUMP NO. 1-2: 75HP
 CHECK VALVE SIZE
 SUSTAIN: 2"
 PUMP NO. 1-2: 6"
 ISOLATION VALVE SIZES:
 SUSTAIN PUMP: 2"
 PUMP NO. 1-2: 5"
 DISCHARGE ISOLATION VALVE: 8"
 RELIEF VALVE SIZE: 4"
 PUMP STATION DISCONNECT: 400 AMP

POWER REQUIREMENTS:
 480V, 60 HZ, 3 PZ, 201 FLA

EXHAUST FAN REQ'D FOR BUILDING:
 2800 CFM

WET WELL DIMS: Ø60"

WET WELL DEPTH: 11'-6"

MAIN LINE CONNECTION: 8" FL
 NOMINAL PIPE SIZE: TBD
 ACTUAL O.D.: TBD
 TYPE: TBD
 DROP PIPE COVER: N/A

INTAKE FLUME SIZE: N/A

INTAKE FLUME MATERIAL: N/A

PLEASE VERIFY ALL INFO WITH
 YOUR INITIALS AND DATE

PLEASE INDICATE POWER SUPPLY CONDITION BELOW FOR
 FCC COMPLIANCE. REFER TO WATERTRONICS DRAWING #
 FCC-1 FOR ADDITIONAL INFORMATION

- A: CONNECTED THROUGH A COMMERCIAL BUILDING
- B: CONNECTED THROUGH A DEDICATED TRANSFORMER
- C: CONNECTED THROUGH A PAD TRANSFORMER SHARED WITH OTHER NON-RESIDENTIAL EQUIPMENT.
- D: CONNECTED TO A POLE TRANSFORMER ON A RESIDENTIAL POWER GRID.
- E: CONNECTED TO A PAD TRANSFORMER SHARED WITH RESIDENTIAL DWELLINGS.

- APPROVED AS SUBMITTED
- APPROVED AS NOTED
- REVISE AND RESUBMIT

REVIEWED BY: _____

NAME: _____

DATE: _____

PLEASE USE THE SPACE BELOW FOR ANY ADDITIONAL COMMENTS:

DIMENSIONS AND SIZES OF EXISTING STRUCTURES, AND/OR COMPONENTS MUST BE VERIFIED TO WATERTRONICS BEFORE STATION CONSTRUCTION BEGINS.

UNLESS SPECIFIED BY THE CUSTOMER, PUMP HOUSE/CONCRETE SLAB DIMENSIONS ARE RECOMMENDED MINIMUMS FOR NEC AND SERVICE CLEARANCE, AND ARE FOR ILLUSTRATION PURPOSES ONLY. PROJECT MANAGER SHALL BE CONSULTED ON FINAL DESIGN.

THE PUMP STATION PROPOSED HEREIN IS DESIGNED TO BE PLACED IN A PUMP HOUSE FOR PROTECTION FROM THE ENVIRONMENT. IF A PUMP HOUSE IS NOT USED, WATERTRONICS MUST BE NOTIFIED AT TIME OF QUOTATION SO SPECIAL PROVISIONS CAN BE MADE.



PHONE: 1-262-367-5000
 FAX: 1-262-367-5551

SHEET 1 OF 3 SHEETS

DRAWING NO. PRVT12267 08/09/2018
 REV 0 08/09/2018

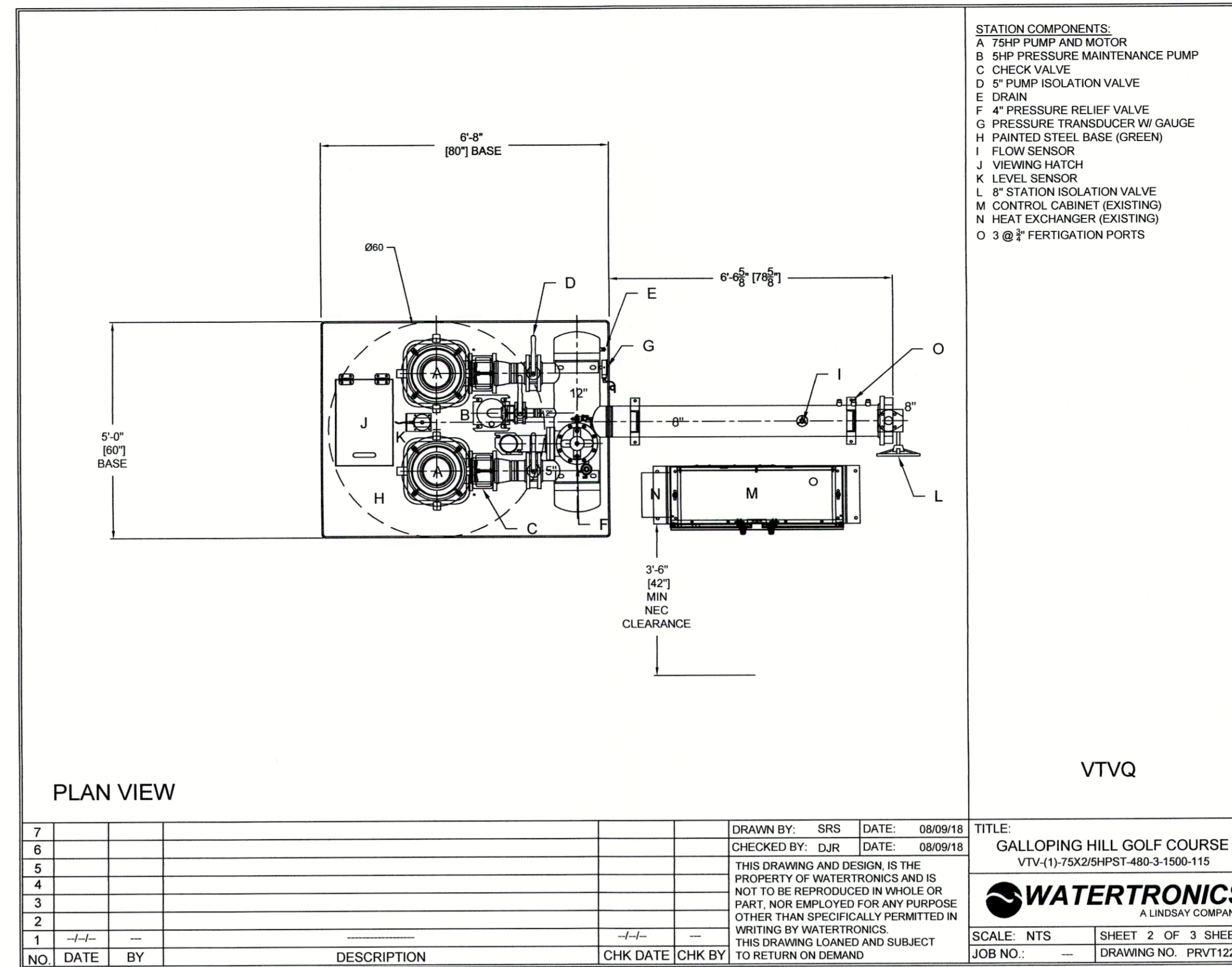

PLAN VIEW

- STATION COMPONENTS:**
 A 75HP PUMP AND MOTOR
 B 5HP PRESSURE MAINTENANCE PUMP
 C CHECK VALVE
 D 5" PUMP ISOLATION VALVE
 E DRAIN
 F 4" PRESSURE RELIEF VALVE
 G PRESSURE TRANSDUCER W/ GAUGE
 H PAINTED STEEL BASE (GREEN)
 I FLOW SENSOR
 J VIEWING HATCH
 K LEVEL SENSOR
 L 8" STATION ISOLATION VALVE
 M CONTROL CABINET (EXISTING)
 N HEAT EXCHANGER (EXISTING)
 O 3 @ 1/2" FERTIGATION PORTS

VTVQ

7						DRAWN BY: SRS	DATE: 08/09/18	TITLE:	GALLOPING HILL GOLF COURSE
6						CHECKED BY: DJR	DATE: 08/09/18		VTV-(1)-75X2/5HPST-480-3-1500-115
5						THIS DRAWING AND DESIGN IS THE PROPERTY OF WATERTRONICS AND IS NOT TO BE REPRODUCED IN WHOLE OR PART, NOR EMPLOYED FOR ANY PURPOSE OTHER THAN SPECIFICALLY PERMITTED IN WRITING BY WATERTRONICS. THIS DRAWING LOANED AND SUBJECT TO RETURN ON DEMAND.			
4									
3									
2									
1									
NO.	DATE	BY	DESCRIPTION	CHK DATE	CHK BY			SCALE: NTS	SHEET 2 OF 3 SHEETS
								JOB NO.:	DRAWING NO. PRVT12267

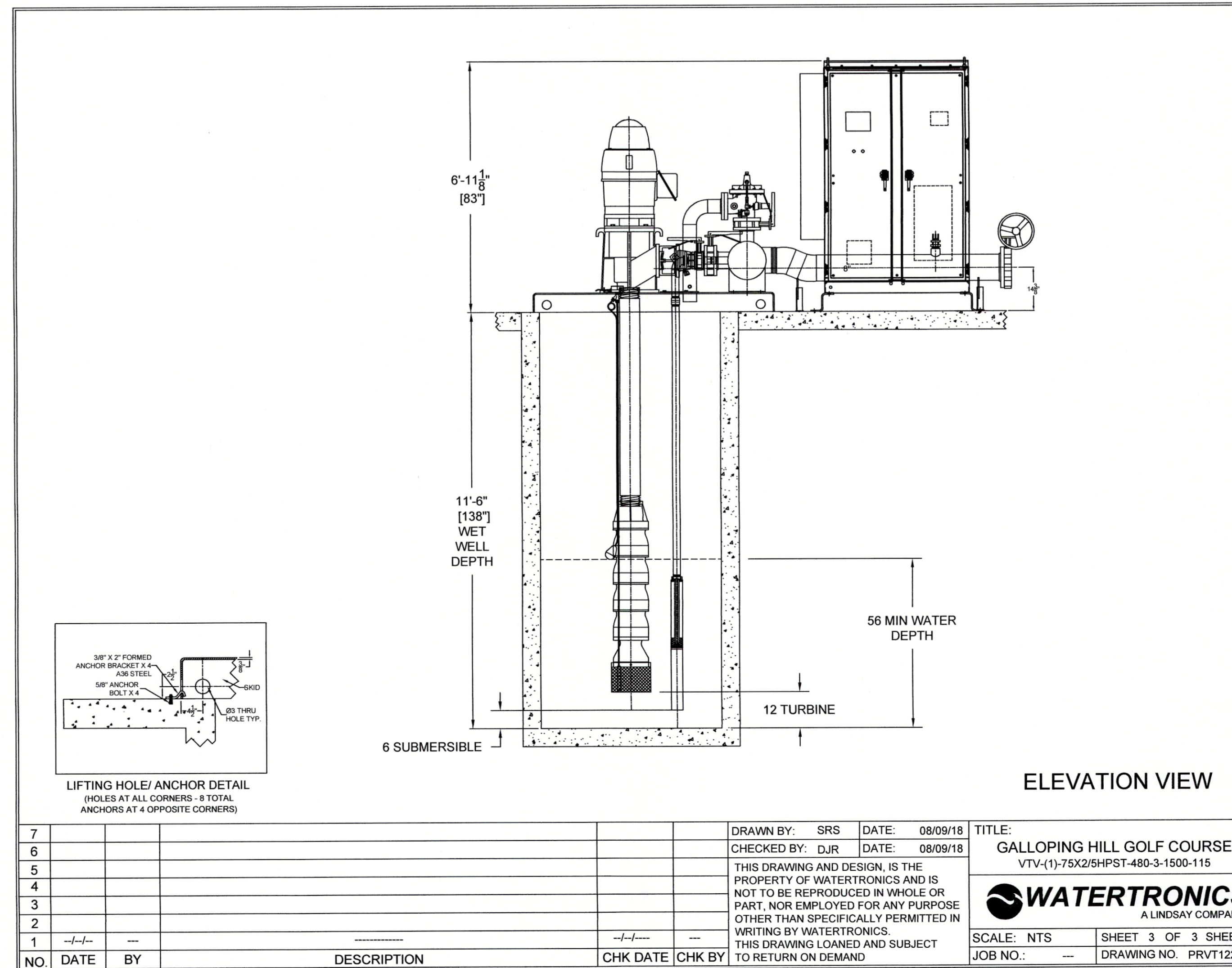

ELEVATION VIEW

7						DRAWN BY: SRS	DATE: 08/09/18	TITLE:	GALLOPING HILL GOLF COURSE
6						CHECKED BY: DJR	DATE: 08/09/18		VTV-(1)-75X2/5HPST-480-3-1500-115
5						THIS DRAWING AND DESIGN IS THE PROPERTY OF WATERTRONICS AND IS NOT TO BE REPRODUCED IN WHOLE OR PART, NOR EMPLOYED FOR ANY PURPOSE OTHER THAN SPECIFICALLY PERMITTED IN WRITING BY WATERTRONICS. THIS DRAWING LOANED AND SUBJECT TO RETURN ON DEMAND.			
4									
3									
2									
1									
NO.	DATE	BY	DESCRIPTION	CHK DATE	CHK BY			SCALE: NTS	SHEET 3 OF 3 SHEETS
								JOB NO.:	DRAWING NO. PRVT12267

GALLOPING HILL G.C.
2019 IRRIGATION IMPROVEMENT PROJECT

BOROUGH OF KENILWORTH COUNTY OF UNION, NJ

DETAILS

DIVISION OF ENGINEERING
 COUNTY OF UNION, NJ

THOMAS O. MONEO, P. E.
 DIRECTOR OF ENGINEERING
 COUNTY ENGINEER
 N.J. LIC. NO. 19646

DATE: 3/11/19

SHEET 4 OF 4