



COUNTY OF UNION

DEPARTMENT OF ENGINEERING, PUBLIC WORKS & FACILITIES MANAGEMENT
Joseph A. Graziano Sr., Director

BOARD OF
CHOSEN FREEHOLDERS

ALEXANDER MIRABELLA
Chairman

ANGELA R. GARRETSON

SERGIO GRANADOS

CHRISTOPHER HUDAK

BETTE JANE KOWALSKI

KIMBERLY PALMIERI-MOUDED

ANDREA STATEN

REBECCA WILLIAMS

EDWARD T. OATMAN
County Manager

AMY C. WAGNER
Deputy County Manager

BRUCE H. BERGEN, ESQ.
County Counsel

JAMES E. PELLETTIERE, RMC
Clerk of the Board

MEMORANDUM

TO: All Potential Bidders

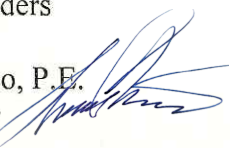
FROM: Thomas O. Mineo, P.E.
County Engineer 

DATE: November 6, 2020

RE: CLARIFICATION - NUMBER 2
Intersection Improvements at South Michigan
Avenue and Quinton Avenue,
Borough of Kenilworth, County of Union,
New Jersey
BA# 20-2020,
Union County Engineering Project #2018-012

The drawings have been replaced with a higher resolution version. No changes have been made to the drawings.

THOMAS O. MINEO, P.E.
*County Engineer,
Director, Division of Engineering*

DIVISION OF ENGINEERING



COUNTY OF UNION BOARD OF CHOSEN FREEHOLDERS PLANS FOR INTERSECTION IMPROVEMENTS AT SOUTH MICHIGAN AVENUE AND QUINTON AVENUE UNION COUNTY PROJECT NO. 2018-012

LIST OF UTILITIES AND EMERGENCY CONTACT INFORMATION

FIRE DEPARTMENT:	KENILWORTH FIRE DEPARTMENT CHIEF WILLIAM KRUEGER 491 WASHINGTON AVENUE KENILWORTH, NJ 07033 908-276-3791
POLICE DEPARTMENT:	KENILWORTH POLICE DEPARTMENT CHIEF JOHN ZIMMERMAN 567 BOULEVARD KENILWORTH, NJ 07033 908-276-1700
PUBLIC WORKS:	KENILWORTH PUBLIC WORKS JOSEPH KANIA 401 SHERIDAN AVENUE KENILWORTH, NJ 07033 908-276-5073
SEWER:	KENILWORTH PUBLIC WORKS JOSEPH KANIA 401 SHERIDAN AVENUE KENILWORTH, NJ 07033 908-276-5073
WATER:	NEW JERSEY AMERICAN WATER SHERRY CHARLES 600 SOUTH AVENUE WEST WESTFIELD, NJ 07090 908-791-3414
ELECTRIC:	PSE&G EDWARD GRAY 80 PARK PLAZA, T-12 NEWARK, NJ 07102
CABLE:	COMCAST RICH GUGULSKI 800 RAHWAY AVENUE UNION CITY, NJ 07083
GAS:	ELIZABETHTOWN GAS GREGORY J. BALINT 520 GREEN LANE UNION, NJ 07083 800-242-5830
TELEPHONE:	VERIZON BILL SCHNEIDER 175 W MAIN STREET FREEHOLD, NJ 07728

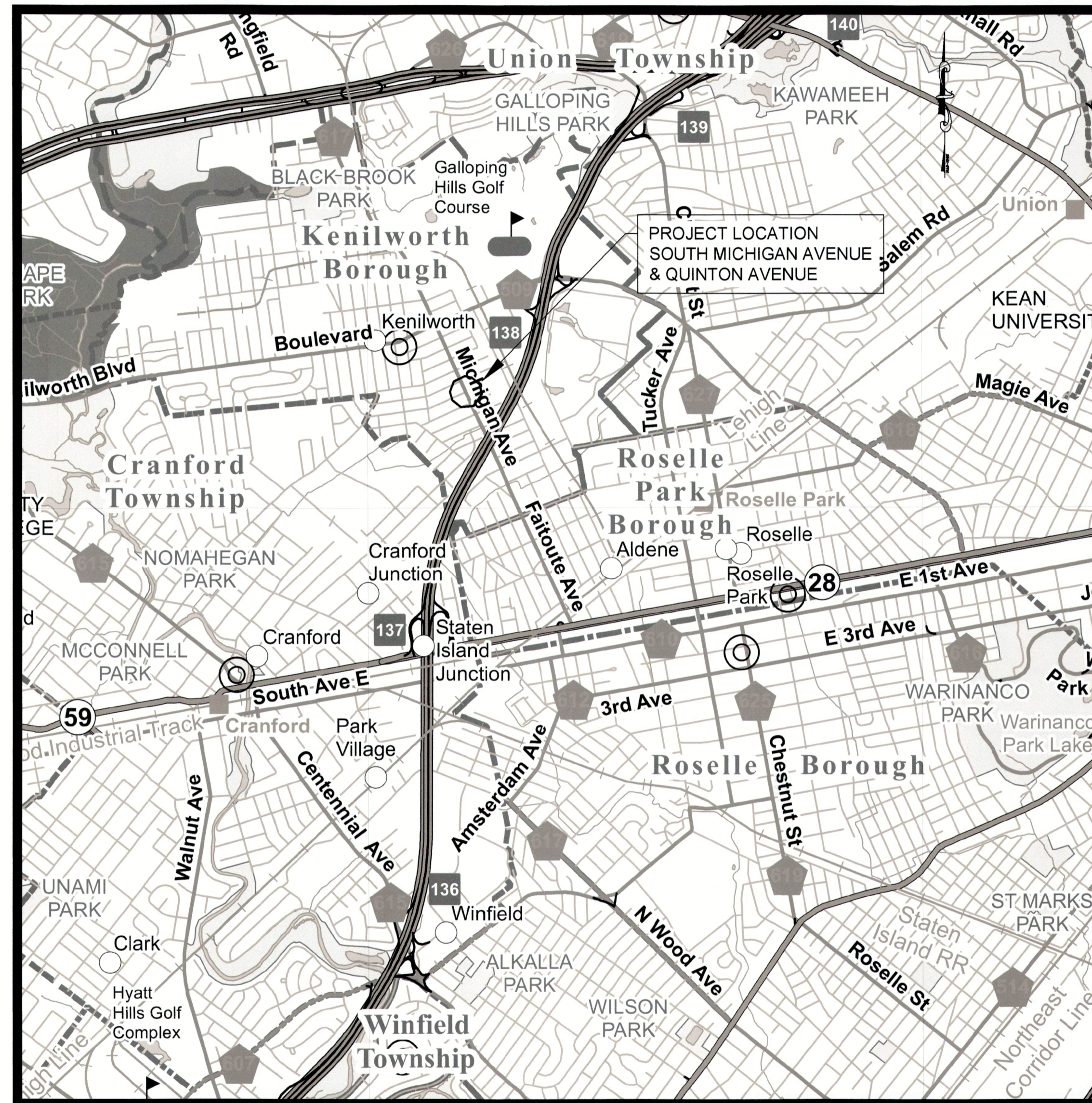

PROJECT LOCATION MAP
NOT TO SCALE

THE BOUND VERSION OF THE NEW JERSEY DEPARTMENT OF TRANSPORTATION STANDARD SPECIFICATIONS FOR ROAD AND BRIDGE CONSTRUCTION OF 2007 (U.S. CUSTOMARY ENGLISH UNITS) AND ALL AMENDMENTS IN THE SUPPLEMENTAL SPECIFICATION FORMAT THERE TO SHALL GOVERN.

THE NEW JERSEY DEPARTMENT OF TRANSPORTATION "STANDARD ROADWAY CONSTRUCTION\TRAFFIC CONTROL\BRIDGE CONSTRUCTION DETAILS" BOOKLET DATED 2007 AND "ELECTRICAL BUREAU STANDARD DETAILS, 2007" AND ALL BASELINE DOCUMENT CHANGES MADE TO THESE CONSTRUCTION DETAILS, SHALL GOVERN, EXCEPT FOR THOSE DETAILS CONTAINED HEREIN.

BOROUGH OF KENILWORTH UNION COUNTY, NEW JERSEY

JUNE 2020

SHEET INDEX	
SHEET #	DESCRIPTION
1	TITLE SHEET
2	ESTIMATE AND DISTRIBUTION OF QUANTITIES
3	GENERAL NOTES
4	LEGEND
5	SIGNALIZATION PLAN
6	SIGNAGE & STRIPING PLAN
7	ELECTRICAL PLAN
8	CONSTRUCTION DETAILS
9	SIGNAL TIMING SCHEDULE

APPROVALS		
RECOMMENDED FOR APPROVAL BY		10/7/20 DATE
	HARBOR CONSULTANTS, BOROUGH OF KENILWORTH, ENGINEER	
RECOMMENDED FOR APPROVAL BY		10-8-20 DATE
	LINDA KARLOVICH, BOROUGH OF KENILWORTH, MAYOR	
RECOMMENDED FOR APPROVAL BY		10/14/2020 DATE
	THOMAS O. MINEO, P.E., COUNTY ENGINEER	
APPROVED BY		10/15/20 DATE
	EDWARD T. OATMAN, COUNTY MANAGER	



DATE: 10/28/2020
FRANK J. SENEY JR.
NJ PROFESSIONAL ENGINEER LIC. No. 35321

PLANS WHICH DO NOT BEAR AN EMBOSSED SEAL ARE NOT VALID

ALL DOCUMENTS PREPARED BY REMINGTON & VERNICK ENGINEERS AND AFFILIATES ARE INSTRUMENTS OF SERVICE IN RESPECT OF THE PROJECT. THEY ARE NOT INTENDED OR REPRESENTED TO BE SUITABLE FOR REUSE BY OWNER OR OTHERS ON EXTENSIONS OF THE PROJECT OR ON ANY OTHER PROJECT. ANY REUSE WITHOUT WRITTEN VERIFICATION OR ADAPTATION BY REMINGTON & VERNICK ENGINEERS AND AFFILIATES FOR THE SPECIFIC PURPOSE INTENDED WILL BE AT OWNERS SOLE RISK AND WITHOUT LIABILITY OR LEGAL EXPOSURE TO REMINGTON & VERNICK ENGINEERS AND AFFILIATES. OWNER SHALL INDEMNIFY AND HOLD HARMLESS REMINGTON & VERNICK ENGINEERS AND AFFILIATES FROM ALL CLAIMS, DAMAGES, LOSSES AND EXPENSES ARISING OUT OF OR RESULTING THEREFROM.

NO.	REVISION	DATE	BY

TITLE SHEET

UNION COUNTY
INTERSECTION IMPROVEMENTS
SOUTH MICHIGAN AVENUE AND QUINTON AVENUE
BOROUGH OF KENILWORTH
UNION COUNTY
NEW JERSEY

DRAWN BY	DESIGN BY	CHECKED BY	SCALE
			AS NOTED
DATE:	SHEET No.:		
JUNE 2020	1		9
JOB No.:			
2000F015			

**New Jersey One Call
CALL BEFORE YOU DIG
811 or 1-800-272-1000
IT'S THE LAW**

IT IS THE RESPONSIBILITY OF THE CONTRACTOR TO CONTACT NJ ONE CALL PRIOR TO THE START OF CONSTRUCTION. CALL FOR MARKOUTS THREE (3) FULL BUSINESS DAYS IN ADVANCE AND BEGIN EXCAVATION WITHIN 10 DAYS. ALL CONTRACTORS ON-SITE MUST HAVE THEIR OWN MARKOUT.

ESTIMATE/DISTRIBUTION OF QUANTITIES

#	DESCRIPTION	UNITS	Signage & Striping Plan	Electrical Plan	PLAN QUANTITY	IF & WHERE DIRECTED	BID QUANTITY
1	CONSTRUCTION LAYOUT	LS			1	0	1
2	SOIL EROSION AND SEDIMENT CONTROL	LS			1	0	1
3	NO ITEM	-			-	-	-
4	DRUM	UN			0	50	50
5	TRAFFIC CONE	UN			0	50	50
6	CONSTRUCTION SIGNS	SF			0	150	150
7	POLICE TRAFFIC DIRECTOR	ALLOWANCE					ALLOWANCE
8	CLEARING SITE	LS			1	0	1
9	TRAFFIC CONTROL TRUCK WITH MOUNTED CRASH CUSHION	UN			1	0	1
10	TRAFFIC DIRECTOR, FLAGGER	HR			16	0	16
11	FLASHING ARROW BOARD 2' X 4'	UN			1	0	1
12	NO ITEM	-			-	-	-
13	NO ITEM	-			-	-	-
14	NO ITEM	-			-	-	-
15	NO ITEM	-			-	-	-
16	TRAFFIC MARKINGS, LINES, THERMOPLASTIC, 24"	LF	30		30	5	35
17	REGULATORY AND WARNING SIGN	SF	47		47	8	55
18	REMOVAL OF TRAFFIC STRIPES	LF	68		68	12	80
19	TRAFFIC SIGNAL HEAD	UN		4	4	0	4
20	ADVANCED PUSH BUTTON	UN		2	2	0	2
21	TRAFFIC SIGNAL CABLE, 2 CONDUCTOR	LF		130	130	20	150
22	TRAFFIC SIGNAL CABLE, 5 CONDUCTOR	LF		130	130	20	150
23	TRAFFIC SIGNAL CABLE, 10 CONDUCTOR	LF		408	408	42	450
24	ADVANCED PEDESTRIAN CONTROLLER	UN		1	1	0	1
25	3" RIGID METALLIC CONDUIT, TYPE CUG	LF		89	89	16	105
26	CONTROLLER, 2 PHASE	UN		1	1	0	1
27	FOUNDATION, TYPE P-MC	UN		1	1	0	1
28	FOUNDATION, TYPE STF	UN		1	1	0	1
29	FOUNDATION, TYPE SPF	UN		1	1	0	1
30	18" X 36" JUNCTION BOX	UN		2	2	0	2
31	SERVICE WIRE, NO. 6 AWG	LF		20	20	10	30
32	GROUND WIRE, NO. 8 AWG	LF		130	130	20	150
33	TRAFFIC SIGNAL STANDARD, STEEL, BLACK	UN		1	1	0	1
34	TRAFFIC SIGNAL MAST ARM, STEEL, BLACK	UN		1	1	0	1
35	PEDESTRIAN SIGNAL STANDARD, BLACK	UN		1	1	0	1
36	PEDESTRIAN SIGNAL HEAD	UN		2	2	0	2
37	UPS SYSTEM, COMPLETE	UN		1	1	0	1
38	METER CABINET, TYPE T	UN		1	1	0	1
39	CONTROLLER TURN-ON	UN		1	1	0	1
40	CONCRETE SIDEWALK, 4" THICK	SY				25	25
41	DETECTABLE WARNING SURFACE	SY				2	2
42	TOPSOIL SPREADING, 4" THICK	SY				25	25
43	FERTILIZING AND SEEDING, TYPE A-3	SY				25	25
44	FIBER MULCH	SY				25	25



REMINGTON & VERNICK ENGINEERS
 232 KINGS HIGHWAY EAST
 HADDONFIELD, NJ 08033
 (856) 795-9595, FAX (856) 795-1882
 WEB SITE ADDRESS : WWW.RVE.COM
 Certification of Authorization: 24 CA 28003300
 ~ENGINEERING EXCELLENCE~

DATE: 10/28/2020

FRANK J. SENEY JR.
 NJ PROFESSIONAL ENGINEER LIC. No. 35321

PLANS WHICH DO NOT BEAR AN EMBOSSED SEAL ARE NOT VALID.

ALL DOCUMENTS PREPARED BY REMINGTON & VERNICK ENGINEERS AND AFFILIATES ARE INSTRUMENTS OF SERVICE IN RESPECT OF THE PROJECT. THEY ARE NOT INTENDED OR REPRESENTED TO BE SUITABLE FOR REUSE BY OWNER OR OTHERS ON EXTENSIONS OF THE PROJECT OR ON ANY OTHER PROJECT. ANY REUSE WITHOUT WRITTEN VERIFICATION OR ADAPTATION BY REMINGTON & VERNICK ENGINEERS AND AFFILIATES FOR THE SPECIFIC PURPOSE INTENDED WILL BE AT OWNERS SOLE RISK AND WITHOUT LIABILITY OR LEGAL EXPOSURE TO REMINGTON & VERNICK ENGINEERS AND AFFILIATES. AND OWNER SHALL INDEMNIFY AND HOLD HARMLESS REMINGTON & VERNICK ENGINEERS AND AFFILIATES FROM ALL CLAIMS, DAMAGES, LOSSES AND EXPENSES ARISING OUT OF OR RESULTING THEREFROM.

NO.	REVISION	DATE	BY/CHK

ESTIMATE & DISTRIBUTION OF QUANTITIES

UNION COUNTY
 INTERSECTION IMPROVEMENTS
 SOUTH MICHIGAN AVENUE AND QUINTON AVENUE
 BOROUGH OF KENILWORTH
 UNION COUNTY
 NEW JERSEY

DRAWN BY: DESIGN BY: CHECKED BY: SCALE: AS NOTED
 DATE: JUNE 2020
 SHEET No.: 2 of 9
 JOB No.: 2000F015

N:\Projects\2020\06\2000F015\2000F015.dwg, 01/10/2024 17:16 PM

STANDARD LEGEND

NOTE: NOT ALL SYMBOLS MAY BE USED



REMINGTON & VERNICK ENGINEERS
 232 KINGS HIGHWAY EAST
 HADDONFIELD, NJ 08033
 (856) 795-9595, FAX (856) 795-1882
 WEB SITE ADDRESS : WWW.RVE.COM
 Certification of Authorization: 24 CA 28003300
 ~ENGINEERING EXCELLENCE~

DATE: 10/28/2020
FRANK J. SENEY JR.
 NJ PROFESSIONAL ENGINEER LIC. No. 35321

PLANS WHICH DO NOT BEAR AN EMBOSSED SEAL ARE NOT VALID

ALL DOCUMENTS PREPARED BY REMINGTON & VERNICK ENGINEERS AND AFFILIATES ARE INSTRUMENTS OF SERVICE IN RESPECT OF THE PROJECT. THEY ARE NOT INTENDED OR REPRESENTED TO BE SUITABLE FOR REUSE BY OWNER OR OTHERS ON EXTENSIONS OF THE PROJECT OR ON ANY OTHER PROJECT. ANY REUSE WITHOUT WRITTEN VERIFICATION OR ADAPTATION BY REMINGTON & VERNICK ENGINEERS AND AFFILIATES FOR THE SPECIFIC PURPOSE INTENDED WILL BE AT OWNERS SOLE RISK AND WITHOUT LIABILITY OR LEGAL EXPOSURE TO REMINGTON & VERNICK ENGINEERS AND AFFILIATES. AND OWNER SHALL INDEMNIFY AND HOLD HARMLESS REMINGTON & VERNICK ENGINEERS AND AFFILIATES FROM ALL CLAIMS, DAMAGES, LOSSES AND EXPENSES ARISING OUT OF OR RESULTING THEREFROM.

No.	REVISION	DATE	BY/CHK

LEGEND

UNION COUNTY
 INTERSECTION IMPROVEMENTS
 SOUTH MICHIGAN AVENUE AND QUINTON AVENUE
 BOROUGHS OF KENILWORTH
 UNION COUNTY
 NEW JERSEY

ITEM	DESCRIPTION	EXISTING	PROPOSED
	OVERHEAD WIRE		
	SANITARY FORCE MAIN PIPE		
	STORM SEWER PIPE ≤12"		
	STORM SEWER PIPE >12"		
	GAS SERVICE		
	SANITARY SEWER PIPE ≤12"		
	SANITARY SEWER PIPE >12"		
	ELECTRIC SERVICE		
	FIBER OPTIC SERVICE		
	TELEPHONE SERVICE		
	COMMUNICATIONS SERVICE		
	IRRIGATION PIPE		
	WATER SERVICE		
	WATER SHUT-OFF		
	WATER METER		
	WATER VALVE		
	WATER HYDRANT		
	WELL		
	YARD HYDRANT		
	METER PIT		
	GAS SHUT-OFF		
	GAS METER		
	GAS VALVE		
	GAS LINE MARKER		
	CLEANOUT		
	SEWER VENT		
	INLET TYPE A		
	INLET TYPE B		
	INLET TYPE E		
	AREA DRAIN		
	MANHOLES		
	IRRIGATION CONTROL VALVE		
	IRRIGATION BOX		
	IRRIGATION CONTROL BOX		
	SPRINKLER HEAD		
	UNKNOWN VALVE		
	COMMUNICATIONS PEDESTAL		
	COMMUNICATIONS LINE MARKER		
	TELEPHONE PEDESTAL		
	TELEPHONE LINE MARKER		
	ELEC. BOX		
	ELEC. METER		
	ELEC. TRANSFORMER PAD		
	ELEC. VAULT		
	ELEC. LINE MARKER		
	UTILITY POLE		
	GUY ANCHOR		
	ELEC. OUTLET		
	LIGHTS		
	VENT		
	VENT PIPE		

ITEM	DESCRIPTION	EXISTING	PROPOSED
	CROWS FOOT		
	AERIAL TARGET		
	CONCRETE MONUMENT		
	PK / MAG NAIL		
	DRILL HOLE SPIKE		
	DRILL HOLE W/ WINGS		
	STAKE		
	HUB		
	PIN W/ CAP		
	IRON PIPE		
	IRON PIN		
	CROSS CUT		
	DISK		
	STONE		
	REBAR		
	BASELINE		
	CENTERLINE		
	EASEMENT		
	RIGHT-OF-WAY		
	PROPERTY BOUNDARY		
	ADJACENT PROPERTY BOUNDARY		
	RAILROAD TRACKS		
	STATE BOUNDARY		
	MUNICIPAL / COUNTY BOUNDARY		
	BORING LOCATION		
	MONITORING WELL LOCATION		
	TEST PIT LOCATION		
	FRESHWATER WETLAND FLAG		
	FRESHWATER WETLAND LINE		
	FRESHWATER WETLAND BUFFER		
	EDGE OF WATER		
	STREAM CENTERLINE		
	GRASS/SOD		
	DECIDUOUS TREE		
	SHRUBS / BUSH		
	EVERGREENS		
	STUMP		
	WOODS / TREE LINE		
	WIRE FENCE		
	SPLIT RAIL FENCE		
	WOOD / VINYL FENCE		
	CHAIN-LINK FENCE		
	TOP OF BANK / DITCH		
	BOTTOM OF BANK / DITCH		
	CONTOUR (MAJOR)		
	CONTOUR (MINOR)		
	FLOW LINE / SWALE		
	TIME OF CONCENTRATION		
	SPOT GRADE		
	ROADWAY GRADE		
	DRAINAGE FLOW		

ITEM	DESCRIPTION	EXISTING	PROPOSED																																																																																																																																								
	EDGE OF PAVEMENT																																																																																																																																										
	CURB																																																																																																																																										
	PAVEMENT / CONC. / SIDEWALK																																																																																																																																										
	LIMIT OF EXCAVATION																																																																																																																																										
	GUIDE RAIL																																																																																																																																										
	BOLLARD																																																																																																																																										
	MAILBOX																																																																																																																																										
	SIGNS																																																																																																																																										
	FLAG POLE																																																																																																																																										
	BENCH																																																																																																																																										
	PILE																																																																																																																																										
	DETECTABLE WARNING SURFACE																																																																																																																																										
	TYPICAL STRIPING																																																																																																																																										
	ADA STRIPING																																																																																																																																										
	TRAFFIC CONTROL BOX																																																																																																																																										
	TRAFFIC LIGHT																																																																																																																																										
	DEPT. OF TRANSPORTATION MANHOLE																																																																																																																																										
	STATE HIGHWAY DEPARTMENT																																																																																																																																										
	RAILROAD CROSSING BEACON																																																																																																																																										
	CALL BOX																																																																																																																																										
	OIL FILL																																																																																																																																										
	UNDERGROUND STORAGE TANK LID																																																																																																																																										
	RISER PIPE																																																																																																																																										
	RAISED PAVEMENT MARKER																																																																																																																																										
	BBQ GRILL																																																																																																																																										
	WATER FOUNTAIN																																																																																																																																										
	KIOSK																																																																																																																																										
	AIR CONDITIONER																																																																																																																																										
	PARKING METER																																																																																																																																										
	FIRE CONTROL VALVE																																																																																																																																										
	BARRICADE																																																																																																																																										
	PHOTO LOCATION																																																																																																																																										
	BENCHMARK LOCATION																																																																																																																																										
	TYPICAL SECTION ARROW																																																																																																																																										
	MATCH LINE																																																																																																																																										
	TYPICAL NORTH ARROW																																																																																																																																										
	NORTH POINT TO BE USED ON STANDARD CONSTRUCTION SHEETS WHERE BEARINGS REFER TO STATE PLANE COORDINATE SYSTEM.																																																																																																																																										
	ABBREVIATIONS	<table border="0"> <tr><td>APR.</td><td>APRON</td><td>E.B., W.B.</td><td>EASTBOUND, WESTBOUND</td><td>PC</td><td>POINT OF CURVATURE</td><td>S.H.D.</td><td>STATE HIGHWAY DEPARTMENT</td></tr> <tr><td>BL</td><td>BASELINE</td><td>N.B., S.B.</td><td>NORTHBOUND, SOUTHBOUND</td><td>PI</td><td>POINT OF INFLECTION</td><td>SHLD.</td><td>SHOULDER</td></tr> <tr><td>BM</td><td>BENCH MARK</td><td>G</td><td>GUTTER</td><td>PT</td><td>POINT OF TANGENCY</td><td>STY.</td><td>STORY</td></tr> <tr><td>BIT.</td><td>BITUMINOUS</td><td>GR</td><td>GRATE</td><td>PK</td><td>PARKER KAYLON MASONRY NAIL</td><td>T.B.A.</td><td>TO BE ABANDONED</td></tr> <tr><td>BLDG.</td><td>BUILDING</td><td>HW</td><td>HEADWALL</td><td>PROP.</td><td>PROPOSED</td><td>T.B.R.</td><td>TO BE REMOVED</td></tr> <tr><td>CL</td><td>CENTERLINE</td><td>H.D.P.E.</td><td>HIGH DENSITY POLYETHYLENE PIPE</td><td>P.V.C.</td><td>POLYVINYL CHLORIDE PIPE</td><td>TC</td><td>TOP OF CURB</td></tr> <tr><td>C.I.P.</td><td>CAST IRON PIPE</td><td>INV.</td><td>INVERT</td><td>PVC</td><td>POINT OF VERTICAL CURVATURE</td><td>TEL</td><td>TELEPHONE</td></tr> <tr><td>CONC.</td><td>CONCRETE</td><td>IP</td><td>IRON PIN</td><td>PVI</td><td>POINT OF VERTICAL INTERSECTION</td><td>TEMP.</td><td>TEMPORARY</td></tr> <tr><td>C.M.P.</td><td>CORRUGATED METAL PIPE</td><td>J.B.</td><td>JUNCTION BOX</td><td>PVT</td><td>POINT OF VERTICAL TANGENCY</td><td>TYP.</td><td>TYPICAL</td></tr> <tr><td>CULV.</td><td>CULVERT</td><td>L.O.M.</td><td>LIMIT OF MILLING</td><td>R</td><td>RADIUS</td><td>U.D.</td><td>UNDERDRAIN</td></tr> <tr><td>D.C.</td><td>DEPRESSED CURB</td><td>L.O.P.</td><td>LIMIT OF PAVING</td><td>R.C.P.</td><td>REINFORCED CONCRETE PIPE</td><td>U.P.</td><td>UTILITY POLE</td></tr> <tr><td>DH</td><td>DRILL HOLE</td><td>MB</td><td>MAILBOX</td><td>RMC</td><td>RIGID METALLIC CONDUIT</td><td>VAR.</td><td>VARIES</td></tr> <tr><td>DIA.</td><td>DIAMETER</td><td>MAX.</td><td>MAXIMUM</td><td>R.O.W.</td><td>RIGHT OF WAY</td><td>WM</td><td>WATER METER</td></tr> <tr><td>DWY</td><td>DRIVEWAY</td><td>MIN.</td><td>MINIMUM</td><td>R.R.</td><td>RAILROAD</td><td> </td><td> </td></tr> <tr><td>D.I.P.</td><td>DUCTILE IRON PIPE</td><td>NO.</td><td>NUMBER</td><td>RTE.</td><td>ROUTE</td><td> </td><td> </td></tr> <tr><td>EL.</td><td>ELEVATION</td><td>N.T.S.</td><td>NOT TO SCALE</td><td>SAN.</td><td>SANITARY</td><td> </td><td> </td></tr> <tr><td>EX.</td><td>EXISTING</td><td>PERF.</td><td>PERFORATED</td><td>SWK.</td><td>SIDEWALK</td><td> </td><td> </td></tr> </table>	APR.	APRON	E.B., W.B.	EASTBOUND, WESTBOUND	PC	POINT OF CURVATURE	S.H.D.	STATE HIGHWAY DEPARTMENT	BL	BASELINE	N.B., S.B.	NORTHBOUND, SOUTHBOUND	PI	POINT OF INFLECTION	SHLD.	SHOULDER	BM	BENCH MARK	G	GUTTER	PT	POINT OF TANGENCY	STY.	STORY	BIT.	BITUMINOUS	GR	GRATE	PK	PARKER KAYLON MASONRY NAIL	T.B.A.	TO BE ABANDONED	BLDG.	BUILDING	HW	HEADWALL	PROP.	PROPOSED	T.B.R.	TO BE REMOVED	CL	CENTERLINE	H.D.P.E.	HIGH DENSITY POLYETHYLENE PIPE	P.V.C.	POLYVINYL CHLORIDE PIPE	TC	TOP OF CURB	C.I.P.	CAST IRON PIPE	INV.	INVERT	PVC	POINT OF VERTICAL CURVATURE	TEL	TELEPHONE	CONC.	CONCRETE	IP	IRON PIN	PVI	POINT OF VERTICAL INTERSECTION	TEMP.	TEMPORARY	C.M.P.	CORRUGATED METAL PIPE	J.B.	JUNCTION BOX	PVT	POINT OF VERTICAL TANGENCY	TYP.	TYPICAL	CULV.	CULVERT	L.O.M.	LIMIT OF MILLING	R	RADIUS	U.D.	UNDERDRAIN	D.C.	DEPRESSED CURB	L.O.P.	LIMIT OF PAVING	R.C.P.	REINFORCED CONCRETE PIPE	U.P.	UTILITY POLE	DH	DRILL HOLE	MB	MAILBOX	RMC	RIGID METALLIC CONDUIT	VAR.	VARIES	DIA.	DIAMETER	MAX.	MAXIMUM	R.O.W.	RIGHT OF WAY	WM	WATER METER	DWY	DRIVEWAY	MIN.	MINIMUM	R.R.	RAILROAD			D.I.P.	DUCTILE IRON PIPE	NO.	NUMBER	RTE.	ROUTE			EL.	ELEVATION	N.T.S.	NOT TO SCALE	SAN.	SANITARY			EX.	EXISTING	PERF.	PERFORATED	SWK.	SIDEWALK			
APR.	APRON	E.B., W.B.	EASTBOUND, WESTBOUND	PC	POINT OF CURVATURE	S.H.D.	STATE HIGHWAY DEPARTMENT																																																																																																																																				
BL	BASELINE	N.B., S.B.	NORTHBOUND, SOUTHBOUND	PI	POINT OF INFLECTION	SHLD.	SHOULDER																																																																																																																																				
BM	BENCH MARK	G	GUTTER	PT	POINT OF TANGENCY	STY.	STORY																																																																																																																																				
BIT.	BITUMINOUS	GR	GRATE	PK	PARKER KAYLON MASONRY NAIL	T.B.A.	TO BE ABANDONED																																																																																																																																				
BLDG.	BUILDING	HW	HEADWALL	PROP.	PROPOSED	T.B.R.	TO BE REMOVED																																																																																																																																				
CL	CENTERLINE	H.D.P.E.	HIGH DENSITY POLYETHYLENE PIPE	P.V.C.	POLYVINYL CHLORIDE PIPE	TC	TOP OF CURB																																																																																																																																				
C.I.P.	CAST IRON PIPE	INV.	INVERT	PVC	POINT OF VERTICAL CURVATURE	TEL	TELEPHONE																																																																																																																																				
CONC.	CONCRETE	IP	IRON PIN	PVI	POINT OF VERTICAL INTERSECTION	TEMP.	TEMPORARY																																																																																																																																				
C.M.P.	CORRUGATED METAL PIPE	J.B.	JUNCTION BOX	PVT	POINT OF VERTICAL TANGENCY	TYP.	TYPICAL																																																																																																																																				
CULV.	CULVERT	L.O.M.	LIMIT OF MILLING	R	RADIUS	U.D.	UNDERDRAIN																																																																																																																																				
D.C.	DEPRESSED CURB	L.O.P.	LIMIT OF PAVING	R.C.P.	REINFORCED CONCRETE PIPE	U.P.	UTILITY POLE																																																																																																																																				
DH	DRILL HOLE	MB	MAILBOX	RMC	RIGID METALLIC CONDUIT	VAR.	VARIES																																																																																																																																				
DIA.	DIAMETER	MAX.	MAXIMUM	R.O.W.	RIGHT OF WAY	WM	WATER METER																																																																																																																																				
DWY	DRIVEWAY	MIN.	MINIMUM	R.R.	RAILROAD																																																																																																																																						
D.I.P.	DUCTILE IRON PIPE	NO.	NUMBER	RTE.	ROUTE																																																																																																																																						
EL.	ELEVATION	N.T.S.	NOT TO SCALE	SAN.	SANITARY																																																																																																																																						
EX.	EXISTING	PERF.	PERFORATED	SWK.	SIDEWALK																																																																																																																																						

UTILITIES

SITE & ROADWORK

MISC.

GENERAL

ABBREVIATIONS

SURVEY

ENVIRONMENTAL

LANDSCAPING

GRADING

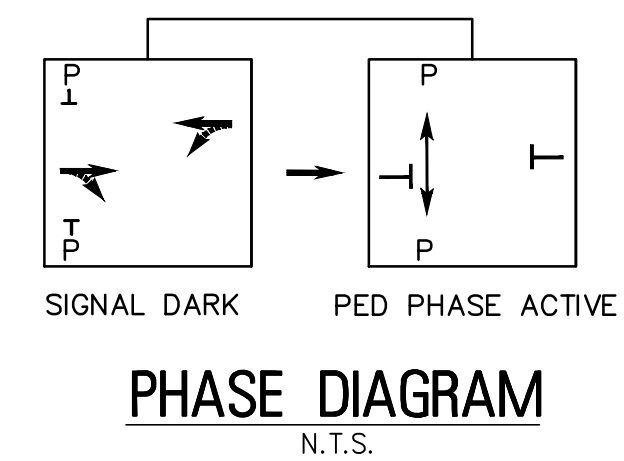

PHASE LEGEND

- PROHIBITED VEHICLE MOVEMENT
- PROTECTED VEHICLE MOVEMENT
- PERMITTED VEHICLE MOVEMENT
- P— PROHIBITED PEDESTRIAN MOVEMENT
- PROTECTED PEDESTRIAN MOVEMENT

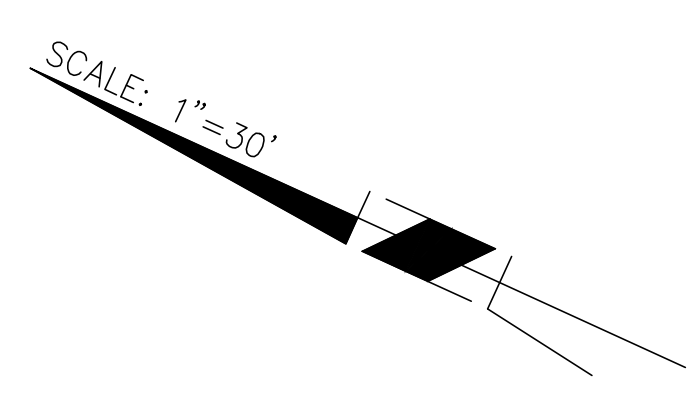
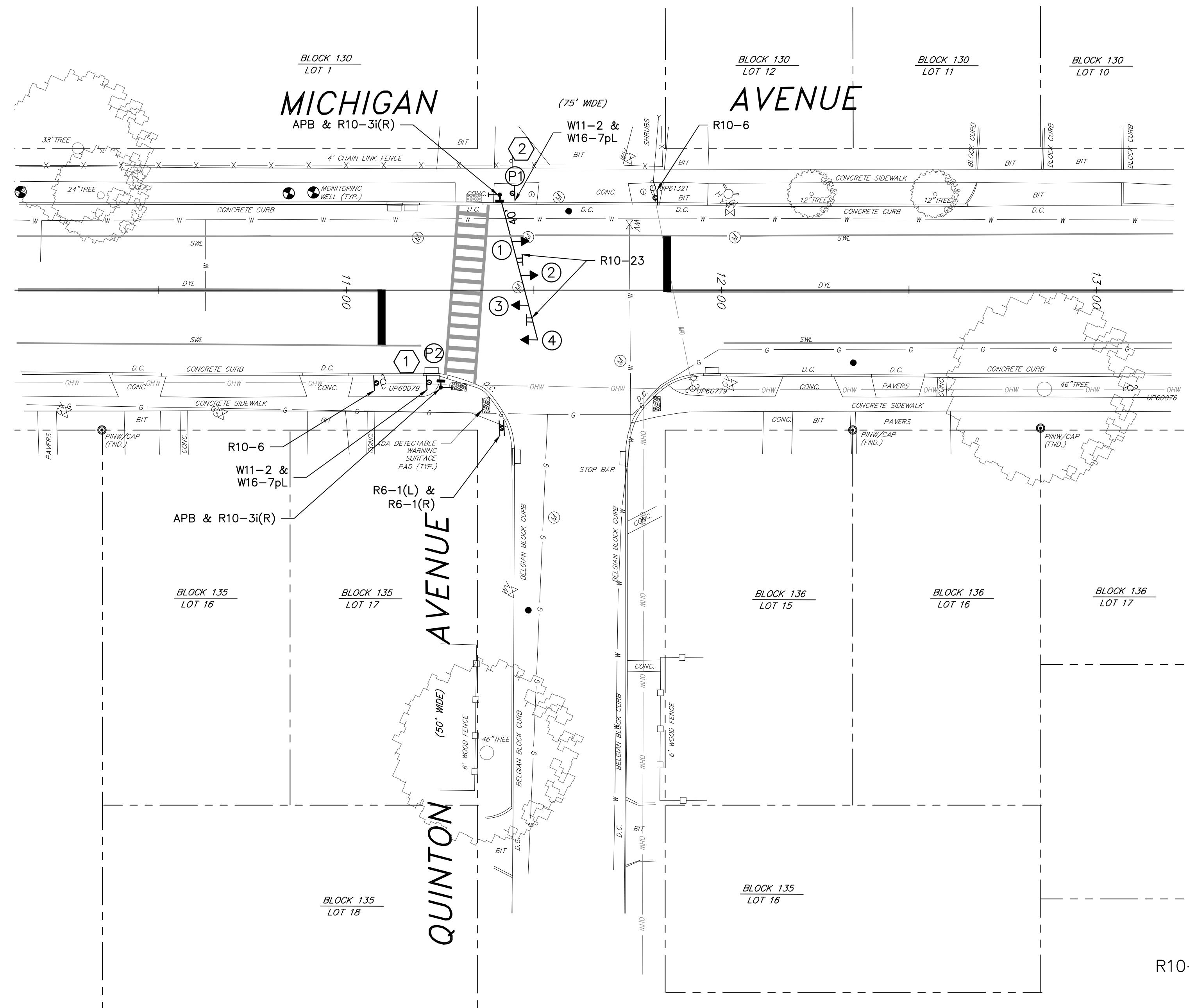

SIGNALIZATION PLAN

SCALE: 1"= 20'

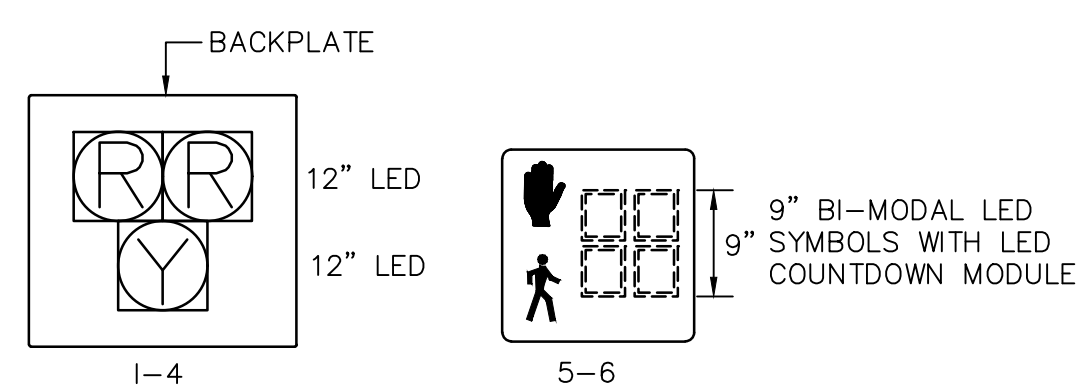

SIGNAL INDICATIONS

SIGN LEGEND		
SIGN DESIGNATION	MESSAGE	SIZE (IN. X IN.)
R6-1(L)	ONE WAY (LEFT ARROW)	36 x 12
R6-1(R)	ONE WAY (RIGHT ARROW)	36 x 12
R10-23	CROSSWALK-STOP ON RED	24 x 30
W11-02	PEDESTRIAN CROSSING	30 x 30
W16-7P	DOWNWARD ARROW	24 x 12
R10-6	STOP HERE ON RED	24 x 36
R10-3i(R)	PEDESTRIAN PUSH BUTTON INSTRUCTIONS (RIGHT ARROW)	9 x 15

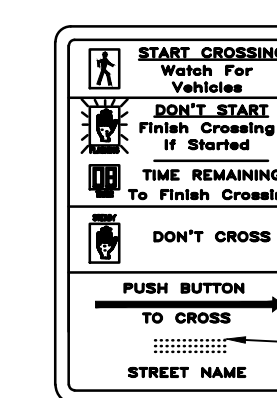
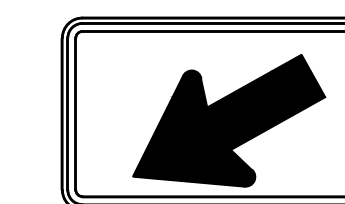
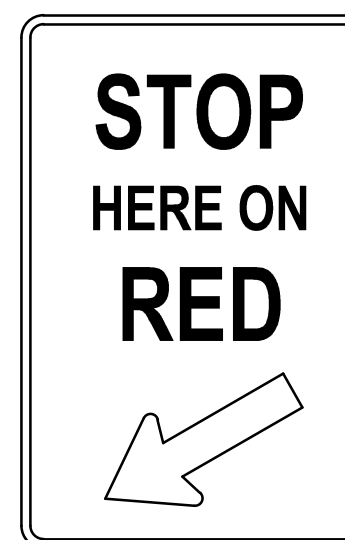
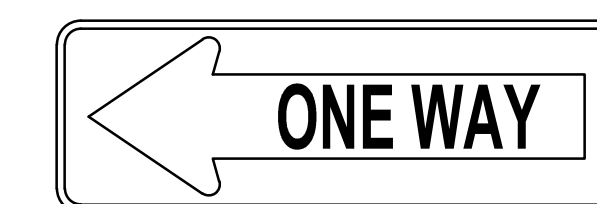
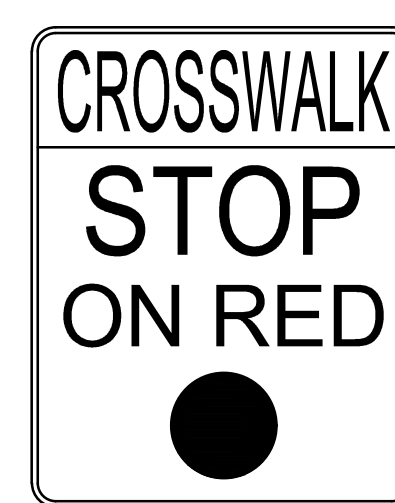

ADD BRAILLE TO STATE 'STREET NAME'.
USE DOMED GRADE 2 BRAILLE AS REQUIRED BY USA A.D.A. STANDARDS

SIGN DETAILS

N.T.S.

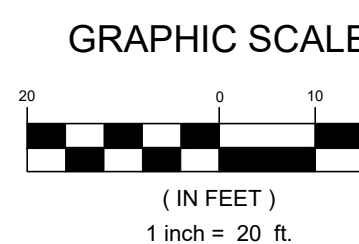

REMINGTON & VERNICK ENGINEERS
232 KINGS HIGHWAY EAST
HADDONFIELD, NJ 08033
(856) 795-9595, FAX (856) 795-1882
WEB SITE ADDRESS : WWW.RVE.COM
Certification of Authorization: 24 CA 28003300
"ENGINEERING EXCELLENCE"

DATE: 10/28/2020
FRANK J. SENEY JR.
NJ PROFESSIONAL ENGINEER LIC. NO. 35321

PLANS WHICH DO NOT BEAR AN EMBOSSED SEAL ARE NOT VALID

ALL DOCUMENTS PREPARED BY REMINGTON & VERNICK ENGINEERS AND AFFILIATES ARE INSTRUMENTS OF SERVICE IN RESPECT OF THE PROJECT. THEY ARE NOT INTENDED OR REPRESENTED TO BE SUITABLE FOR REUSE BY OWNER OR OTHERS ON EXTENSIONS OF THE PROJECT OR ON ANY OTHER PROJECT. ANY REUSE WITHOUT WRITTEN VERIFICATION OR ADAPTATION BY REMINGTON & VERNICK ENGINEERS AND AFFILIATES FOR THE SPECIFIC PURPOSE INTENDED WILL BE AT OWNERS SOLE RISK AND WITHOUT LIABILITY OR LEGAL EXPOSURE TO REMINGTON & VERNICK ENGINEERS AND AFFILIATES. AND OWNER SHALL INDEMNIFY AND HOLD HARMLESS REMINGTON & VERNICK ENGINEERS AND AFFILIATES FROM ALL CLAIMS, DAMAGES, LOSSES AND EXPENSES ARISING OUT OF OR RESULTING THEREFROM.

NO.	REVISION	DATE	BY	CHK

SIGNALIZATION PLAN

UNION COUNTY
INTERSECTION IMPROVEMENTS
SOUTH MICHIGAN AVENUE AND QUINTON AVENUE
BOROUGH OF KENILWORTH UNION COUNTY NEW JERSEY

DATE	DESIGN BY	CHECKED BY	SCALE
JUNE 2020			AS NOTED
JOB No.: 2000F015			5 of 9

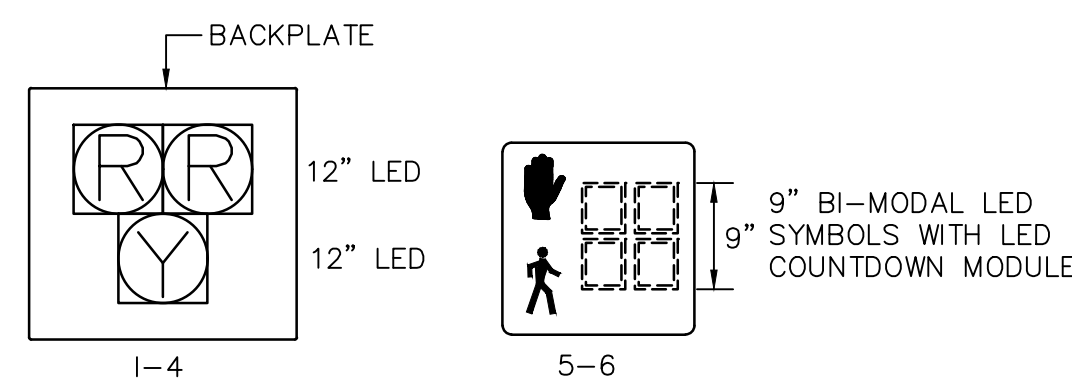
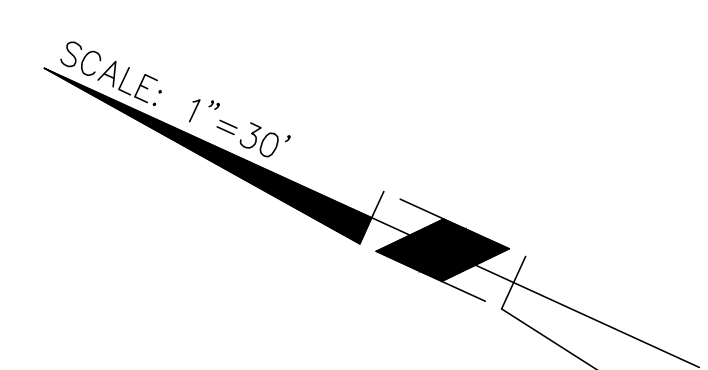

SIGNAL INDICATIONS
N.T.S.

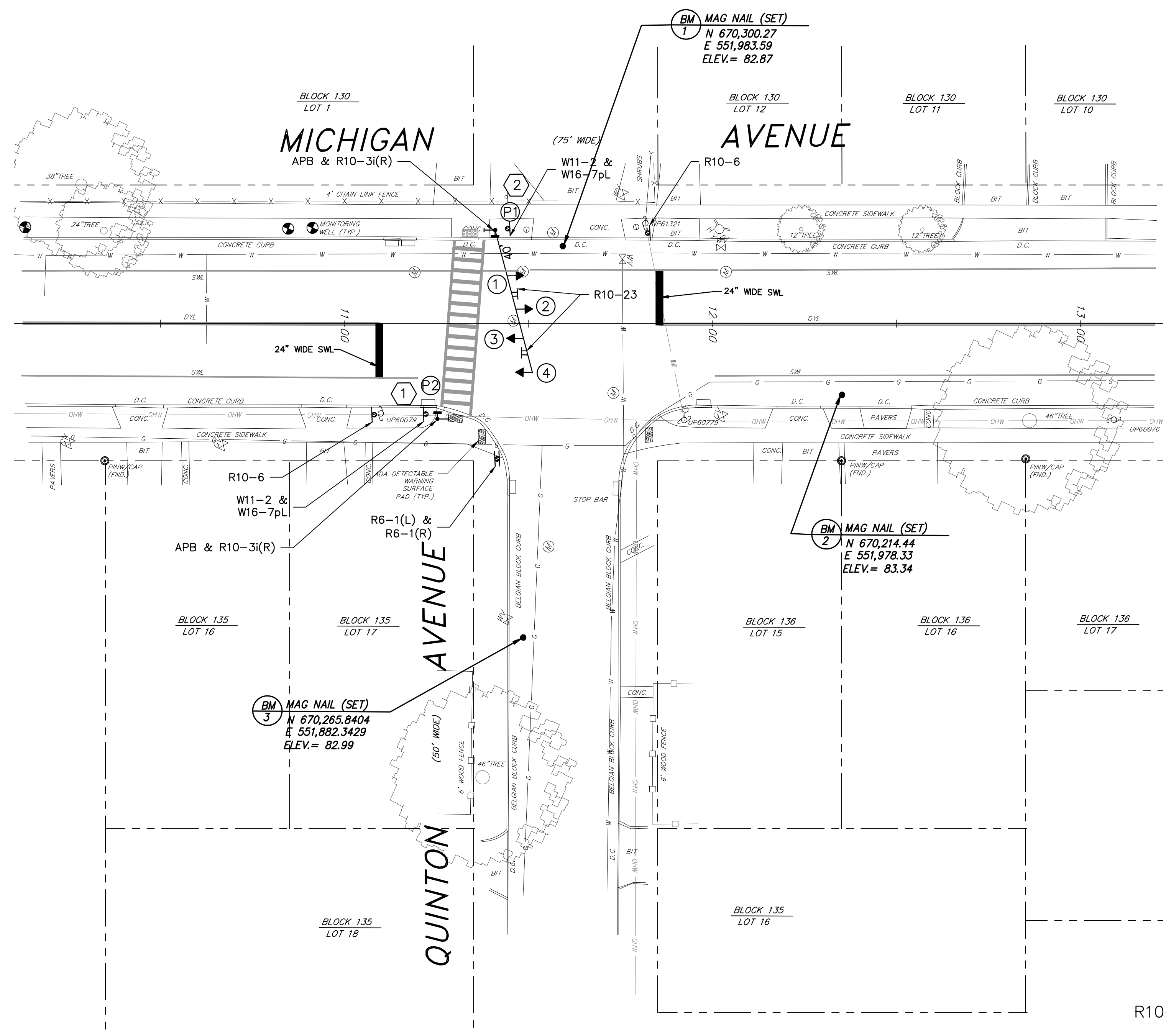

SIGNAGE & STRIPING PLAN
SCALE: 1" = 20'

TO BE CONSTRUCTED

ITEM NO.	DESCRIPTION	UNIT	PLAN QUANTITY	AS-BUILT QUANTITY
16	TRAFFIC MARKINGS, LINES, THERMOPLASTIC, 24"	LF	30	
17	REGULATORY AND WARNING SIGN	SF	47	
18	REMOVAL OF TRAFFIC STRIPES	LF	68	

SIGN LEGEND

SIGN DESIGNATION	MESSAGE	SIZE (IN. X IN.)
R6-1(L)	ONE WAY (LEFT ARROW)	36 x 12
R6-1(R)	ONE WAY (RIGHT ARROW)	36 x 12
R10-23	CROSSWALK-STOP ON RED	24 x 30
W11-02	PEDESTRIAN CROSSING	30 x 30
W16-7P	DOWNWARD ARROW	24 x 12
R10-6	STOP HERE ON RED	24 x 36
R10-3(R)	PEDESTRIAN PUSH BUTTON INSTRUCTIONS (RIGHT ARROW)	9 x 15

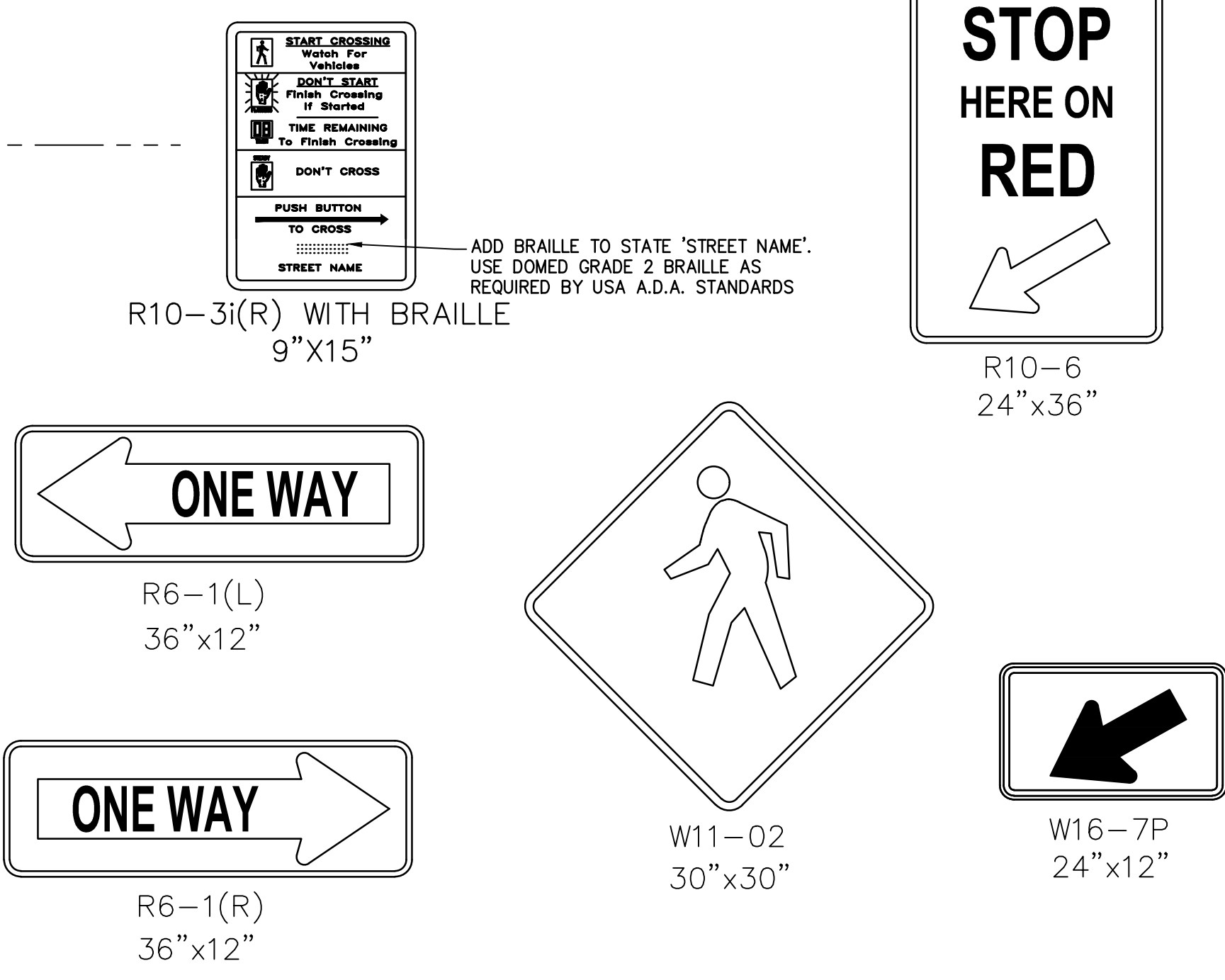

SIGN DETAILS
N.T.S.

GRAPHIC SCALE
0 10 20
1
1 (IN FEET)
1 inch = 20 ft.

RVE
1901
REMINGTON & VERNICK ENGINEERS
232 KINGS HIGHWAY EAST
HADDONFIELD, NJ 08033
(856) 795-9595, FAX (856) 795-1882
WEB SITE ADDRESS : WWW.RVE.COM
Certification of Authorization: 24 CA 28003300
"ENGINEERING EXCELLENCE"

DATE: 10/28/2020
FRANK J. SENEY JR.
NJ PROFESSIONAL ENGINEER LIC. NO. 35321

PLANS WHICH DO NOT BEAR AN EMBOSSED SEAL ARE NOT VALID

ALL DOCUMENTS PREPARED BY REMINGTON & VERNICK ENGINEERS AND AFFILIATES ARE INSTRUMENTS OF SERVICE IN RESPECT OF THE PROJECT. THEY ARE NOT INTENDED OR REPRESENTED TO BE SUITABLE FOR REUSE BY OWNER OR OTHERS ON EXTENSIONS OF THE PROJECT OR ON ANY OTHER PROJECT. ANY REUSE WITHOUT WRITTEN VERIFICATION OR ADAPTATION BY REMINGTON & VERNICK ENGINEERS AND AFFILIATES FOR THE SPECIFIC PURPOSE INTENDED WILL BE AT OWNERS SOLE RISK AND WITHOUT LIABILITY OR LEGAL EXPOSURE TO REMINGTON & VERNICK ENGINEERS AND AFFILIATES. AND OWNER SHALL INDEMNIFY AND HOLD HARMLESS REMINGTON & VERNICK ENGINEERS AND AFFILIATES FROM ALL CLAIMS, DAMAGES, LOSSES AND EXPENSES ARISING OUT OF OR RESULTING THEREFROM.

NO.	REVISION	DATE	BY	CHK

SIGNAGE & STRIPING PLAN

UNION COUNTY
INTERSECTION IMPROVEMENTS SOUTH MICHIGAN AVENUE AND QUINTON AVENUE
UNION COUNTY
BOROUGH OF KENILWORTH
NEW JERSEY

DATE: JUNE 2020
JOB No.: 2000F015
SHEET No.: 6 of 9

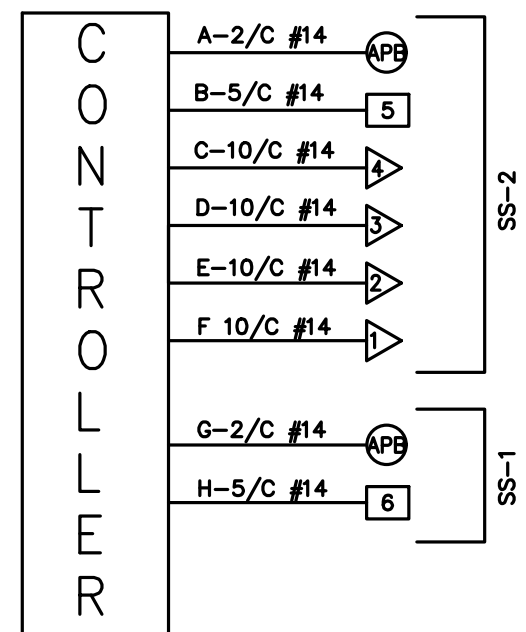

BLOCK WIRING DIAGRAM
N.T.S.

WIRING DIAGRAM LEGEND

- ▶ TRAFFIC SIGNAL HEAD
- 5 PEDESTRIAN SIGNAL HEAD
- APB ADVANCED PUSH BUTTON (APB)

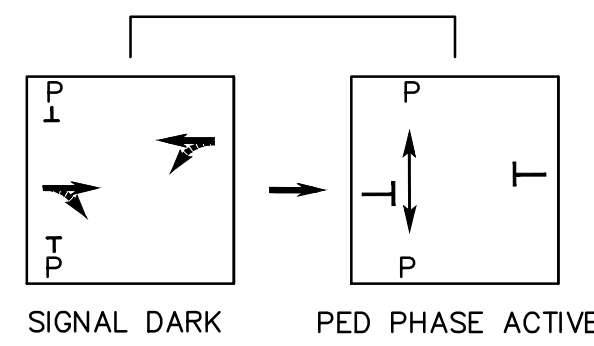

PHASE DIAGRAM
N.T.S.

PHASE LEGEND

- PROHIBITED VEHICLE MOVEMENT
- ▶ PROTECTED VEHICLE MOVEMENT
- ▶ PERMITTED VEHICLE MOVEMENT
- P-1 PROHIBITED PEDESTRIAN MOVEMENT
- P-2 PROTECTED PEDESTRIAN MOVEMENT

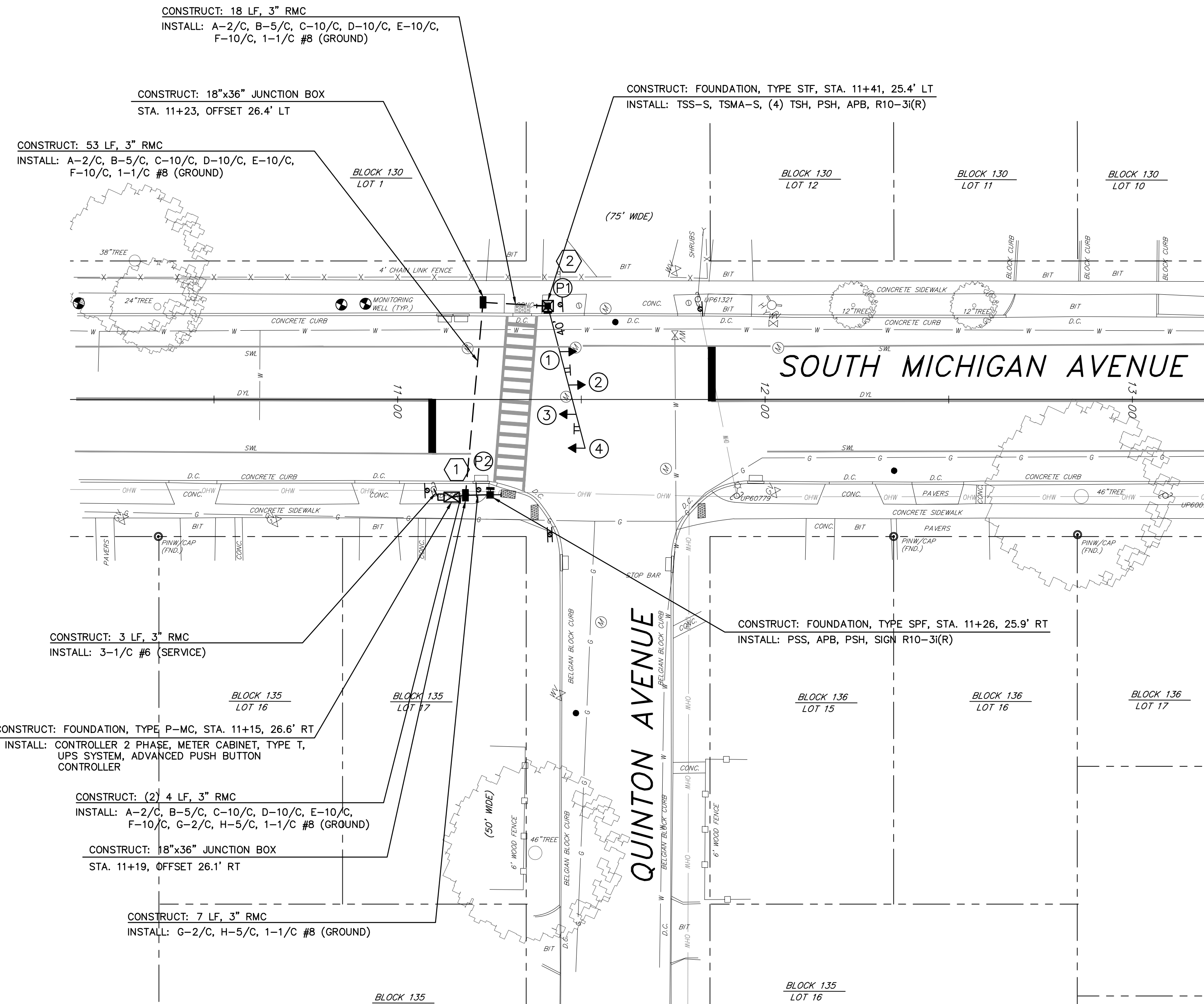

ELECTRICAL PLAN

SCALE: 1" = 20'

NOTES:

1. ALL ALUMINUM & STEEL, ABOVE GROUND ELECTRICAL EQUIPMENT SHALL BE BLACK POWDER COATED.
2. ALL SIGNAL HEAD HOUSINGS SHALL BE BLACK.
3. INSTALL GROUND WIRE (GND), 1/C#8 AWG, INSULATED (COLOR GREEN) CONTINUOUSLY THROUGHOUT THE TRAFFIC SIGNAL SYSTEM. SECURE TO ALL GROUND RODS, CABINETS AND TRAFFIC SIGNAL BASES AS NOTED.

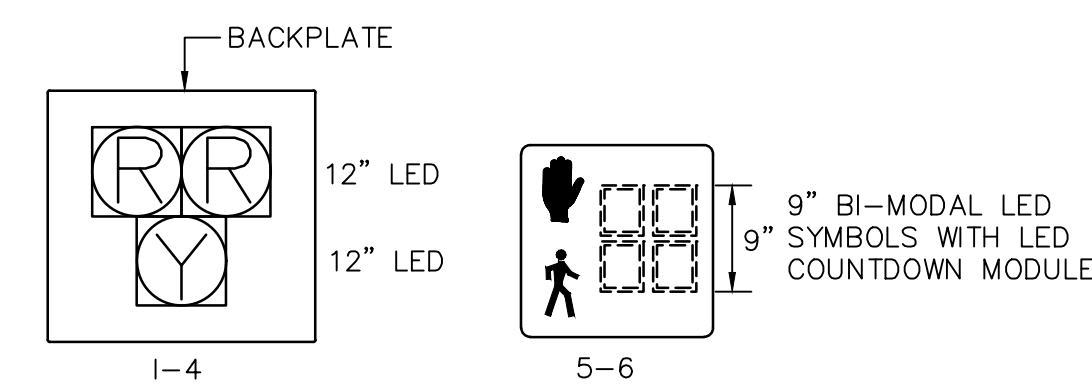

SIGNAL INDICATIONS
N.T.S.

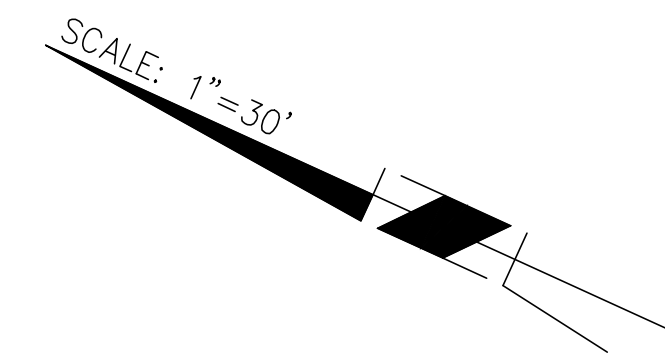

GRAPHIC SCALE

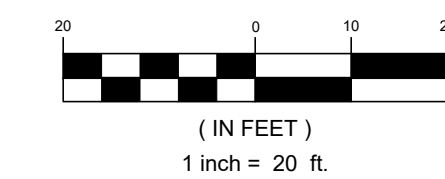

ELECTRICAL PLAN ABBREVIATIONS

- PB PUSH BUTTON
- GRN GROUND
- ID IMAGE DETECTOR
- IDC IMAGE DETECTOR CABLE
- JB JUNCTION BOX
- L LUMINAIRE
- LMA-A LIGHTING MAST ARM, ALUMINUM
- MAS MAST ARM SIGN
- PBS PUSH BUTTON STANDARD
- PSH PEDESTRIAN SIGNAL HEAD
- PSS PEDESTRIAN SIGNAL STANDARD
- RMC RIGID METALLIC CONDUIT
- RNM RIGID NON METALLIC CONDUIT
- TSH TRAFFIC SIGNAL HEAD
- T SMA-A TRAFFIC SIGNAL MAST ARM, ALUMINUM
- T SMA-S TRAFFIC SIGNAL MAST ARM, STEEL
- TSS-K TRAFFIC SIGNAL STANDARD, ALUMINUM "K"
- V VERTICAL LUMINAIRE

SIGNAL LEGEND

- 5 TRAFFIC / PEDESTRIAN SIGNAL HEAD NUMBER
- ▶ TRAFFIC SIGNAL HEAD
- 5 PEDESTRIAN SIGNAL HEAD
- ▶ ADVANCED PUSH BUTTON (APB)
- 5 TRAFFIC SIGNAL STANDARD NUMBER

ITEM NO.	DESCRIPTION	UNIT	CONTRACT QUANTITY
19	TRAFFIC SIGNAL HEAD	UN	4
20	ADVANCED PUSH BUTTON	UN	2
21	TRAFFIC SIGNAL CABLE, 2 CONDUCTOR	LF	130
22	TRAFFIC SIGNAL CABLE, 5 CONDUCTOR	LF	130
23	TRAFFIC SIGNAL CABLE, 10 CONDUCTOR	LF	408
24	ADVANCED PEDESTRIAN CONTROLLER	UN	1
25	3" RIGID METALLIC CONDUIT, TYPE CUG	LF	89
26	CONTROLLER, 2 PHASE	UN	1
27	FOUNDATION, TYPE P-MC	UN	1
28	FOUNDATION, TYPE STF	UN	1
29	FOUNDATION, TYPE SPF	UN	1
30	18" X 36" JUNCTION BOX	UN	2
31	SERVICE WIRE, NO. 6 AWG	LF	20
32	GROUND WIRE, NO. 8 AWG	LF	130
33	TRAFFIC SIGNAL STANDARD, STEEL, BLACK	UN	1
34	TRAFFIC SIGNAL MAST ARM, STEEL, BLACK	UN	1
35	PEDESTRIAN SIGNAL STANDARD, BLACK	UN	1
36	PEDESTRIAN SIGNAL HEAD	UN	2
37	UPS SYSTEM, COMPLETE	UN	1
38	METER CABINET, TYPE T	UN	1
39	CONTROLLER TURN-ON	UN	1



REMINGTON & VERNICK ENGINEERS
232 KINGS HIGHWAY EAST
HADDONFIELD, NJ 08033
(856) 795-9595, FAX (856) 795-1882
WEB SITE ADDRESS : WWW.RVE.COM
Certification of Authorization: 24 GA 28003300
-ENGINEERING EXCELLENCE-

DATE: 10/28/2020
FRANK J. SENEY JR.
NJ PROFESSIONAL ENGINEER LIC. NO. 35321

PLANS WHICH DO NOT BEAR AN EMBOSSED SEAL ARE NOT VALID.
ALL DOCUMENTS PREPARED BY REMINGTON & VERNICK ENGINEERS AND AFFILIATES ARE INSTRUMENTS OF SERVICE IN RESPECT OF THE PROJECT. THEY ARE NOT INTENDED OR REPRESENTED TO BE SUITABLE FOR REUSE BY OWNER OR OTHERS ON EXTENSIONS OF THE PROJECT OR ON ANY OTHER PROJECT. ANY REUSE WITHOUT WRITTEN VERIFICATION OR ADAPTATION BY REMINGTON & VERNICK ENGINEERS AND AFFILIATES FOR THE SPECIFIC PURPOSE INTENDED WILL BE AT OWNERS SOLE RISK AND WITHOUT LIABILITY OR LEGAL EXPOSURE TO REMINGTON & VERNICK ENGINEERS AND AFFILIATES. AND OWNER SHALL INDEMNIFY AND HOLD HARMLESS REMINGTON & VERNICK ENGINEERS AND AFFILIATES FROM ALL CLAIMS, DAMAGES, LOSSES AND EXPENSES ARISING OUT OF OR RESULTING THEREFROM.

NO.	REVISION	DATE	BY	CHK

ELECTRICAL PLAN
UNION COUNTY
INTERSECTION IMPROVEMENTS
SOUTH MICHIGAN AVENUE AND QUINTON AVENUE
BOROUGH OF KENILWORTH
UNION COUNTY
NEW JERSEY

DATE	DESIGN BY	CHECKED BY	SCALE
JUNE 2020			AS NOTED
JOB No.:			
2000F015			



REMINGTON & VERNICK ENGINEERS
 232 KINGS HIGHWAY EAST
 HADDONFIELD, NJ 08033
 (856) 795-9595, FAX (856) 795-1882
 WEB SITE ADDRESS : WWW.RVE.COM
 Certification of Authorization: 24 CA 28003300
 ~ENGINEERING EXCELLENCE~

DATE: 10/28/2020
FRANK J. SENEY JR.
 NJ PROFESSIONAL ENGINEER LIC. No. 35321

PLANS WHICH DO NOT BEAR AN EMBOSSED SEAL ARE NOT VALID

ALL DOCUMENTS PREPARED BY REMINGTON & VERNICK ENGINEERS AND AFFILIATES ARE INSTRUMENTS OF SERVICE IN RESPECT OF THE PROJECT. THEY ARE NOT INTENDED OR REPRESENTED TO BE SUITABLE FOR REUSE BY OWNER OR OTHERS ON EXTENSIONS OF THE PROJECT OR ON ANY OTHER PROJECT. ANY REUSE WITHOUT WRITTEN VERIFICATION OR ADAPTATION BY REMINGTON & VERNICK ENGINEERS AND AFFILIATES FOR THE SPECIFIC PURPOSE INTENDED WILL BE AT OWNERS SOLE RISK AND WITHOUT LIABILITY OR LEGAL EXPOSURE TO REMINGTON & VERNICK ENGINEERS AND AFFILIATES. AND OWNER SHALL INDEMNIFY AND HOLD HARMLESS REMINGTON & VERNICK ENGINEERS AND AFFILIATES FROM ALL CLAIMS, DAMAGES, LOSSES AND EXPENSES ARISING OUT OF OR RESULTING THEREFROM.

NO.	REVISION	DATE	BY	CHK

CONSTRUCTION DETAILS

UNION COUNTY
 INTERSECTION IMPROVEMENTS
 SOUTH MICHIGAN AVENUE AND QUINTON AVENUE
 BOROUGH OF KENILWORTH UNION COUNTY NEW JERSEY

DRAWN BY:	DESIGN BY:	CHECKED BY:	SCALE:
DATE:	JUNE 2020	SHEET No.:	AS NOTED
JOB No.:	2000F015	8	of 9

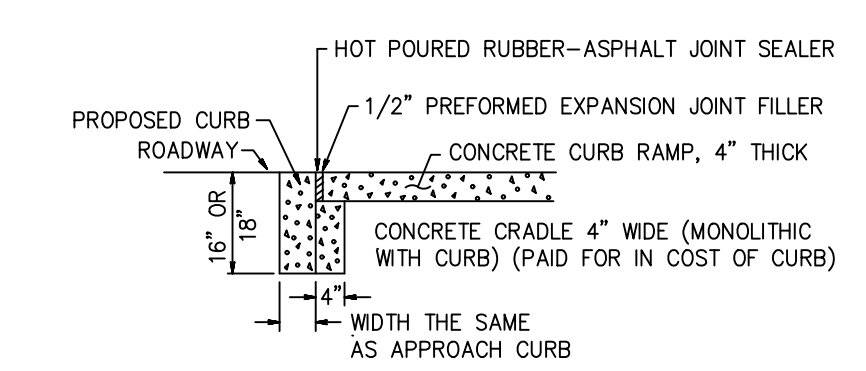

DROPPED CURB AND CRADLE AT ALL PUBLIC SIDEWALK CURB RAMPS
 N.T.S.

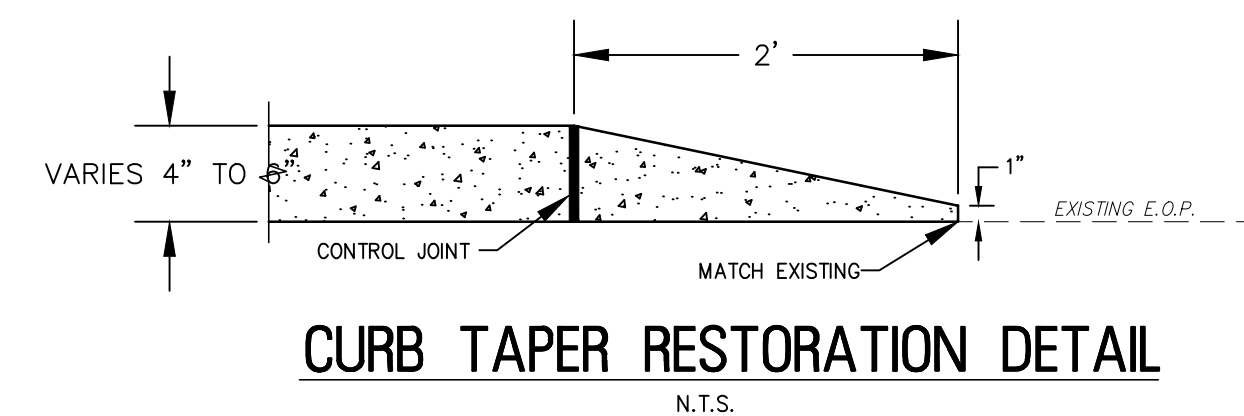

CURB TAPER RESTORATION DETAIL
 N.T.S.

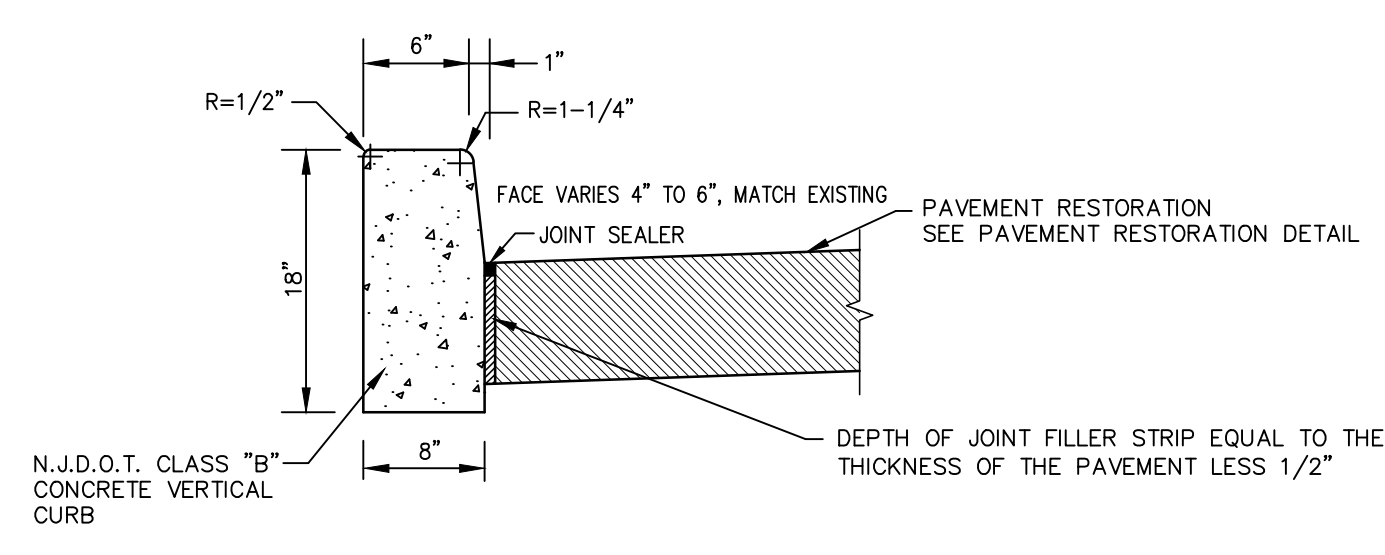

CONCRETE VERTICAL CURB RESTORATION DETAIL
 N.T.S.

NOTES:
 1. TRANSVERSE JOINTS 1/2" WIDE SHALL BE INSTALLED IN THE CURB 20'-0" APART AND SHALL BE FILLED WITH PREFORMED, BITUMINOUS-IMPREGNATED FIBER JOINT FILLER, COMPLYING WITH THE REQUIREMENTS OF AASHTO M-213, RECESSED 1/4" FROM THE FRONT FACE AND TOP OF CURB.
 2. DUMMY JOINTS (FORMED) SHALL BE INSTALLED MIDWAY BETWEEN EXPANSION JOINTS.
 3. NO SEPARATE PAYMENT WILL BE MADE FOR PAVEMENT RESTORATION BUT THE COST SHALL BE INCLUDED IN THE PRICE BID FOR THE CURB

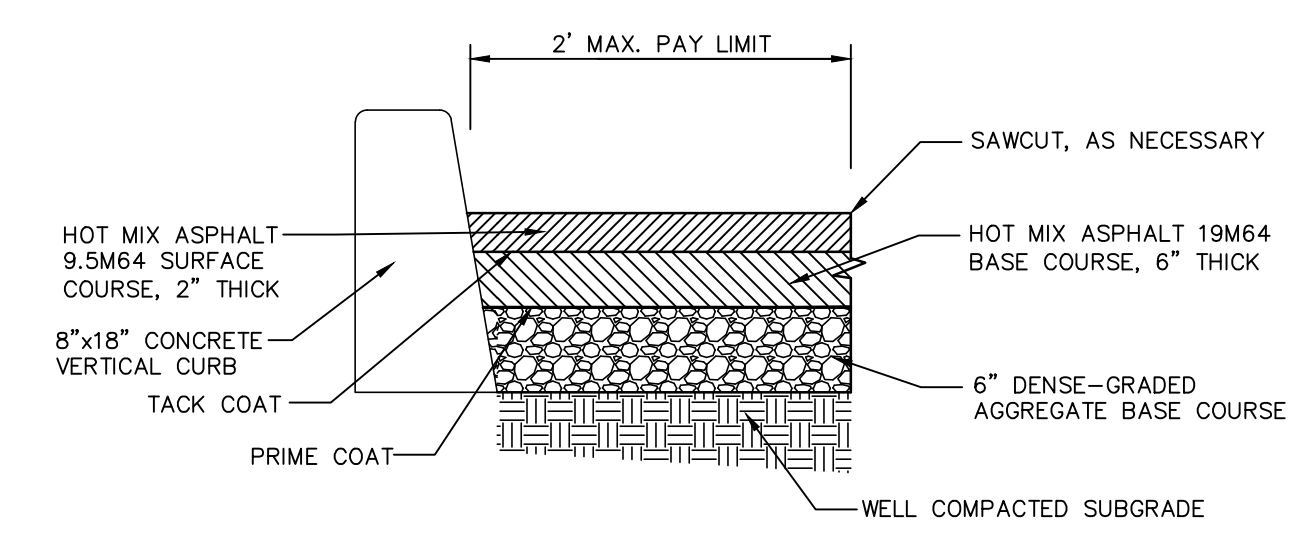

CURB PAVEMENT RESTORATION DETAIL
 N.T.S.

NOTES:
 1. ALL MATERIALS EXCEPT THE HMA SURFACE COURSE AND TACK COAT ARE INCLUDED IN THE "HOT MIX ASPHALT PAVEMENT REPAIR" PAY ITEM.

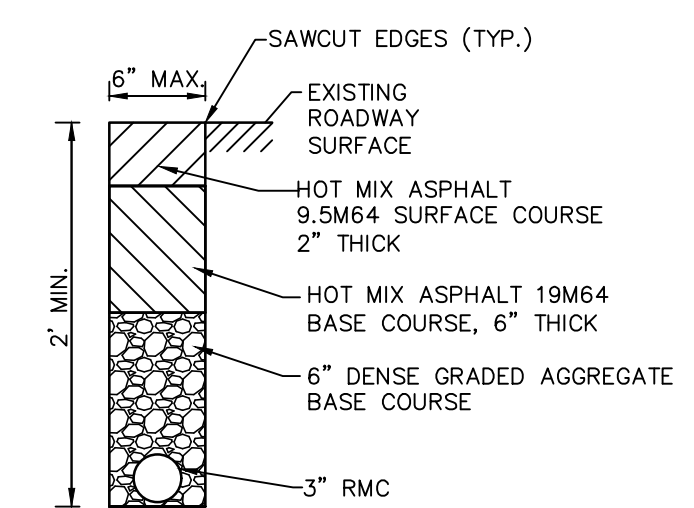

TRENCH RESTORATION DETAIL FOR OPEN CUT METHOD
 N.T.S.

NOTES:
 1. NO SEPARATE PAYMENT WILL BE MADE FOR PAVEMENT RESTORATION BUT THE COST SHALL BE INCLUDED IN THE PRICE BID FOR THE CONDUIT.

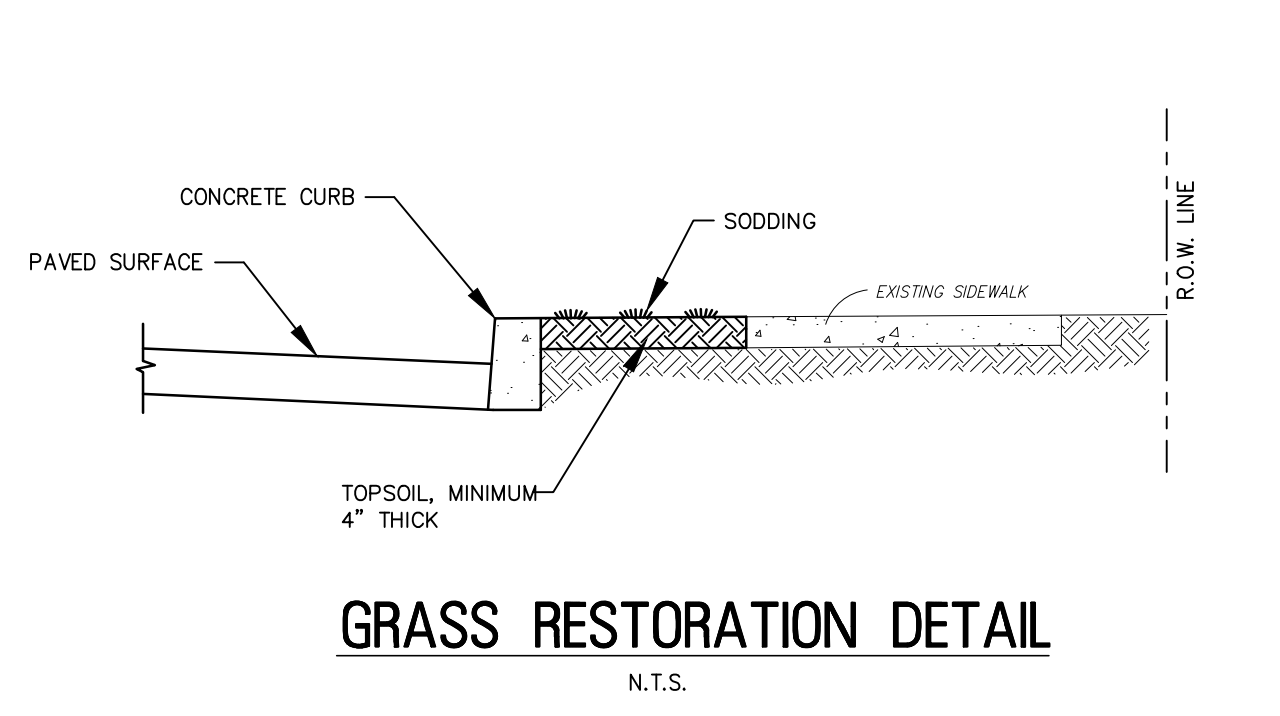

GRASS RESTORATION DETAIL
 N.T.S.

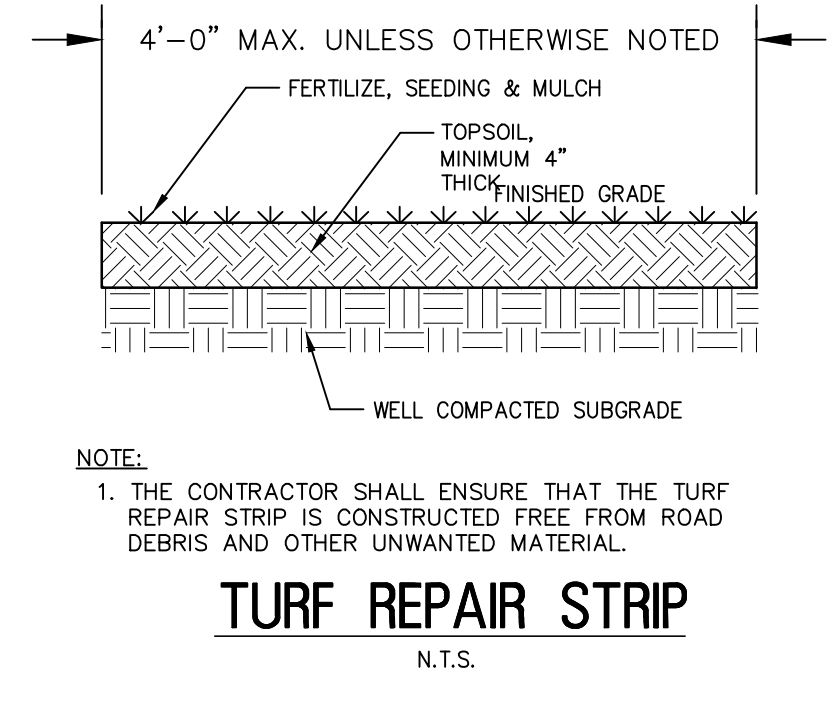

TURF REPAIR STRIP
 N.T.S.

NOTE:
 1. THE CONTRACTOR SHALL ENSURE THAT THE TURF REPAIR STRIP IS CONSTRUCTED FREE FROM ROAD DEBRIS AND OTHER UNWANTED MATERIAL.

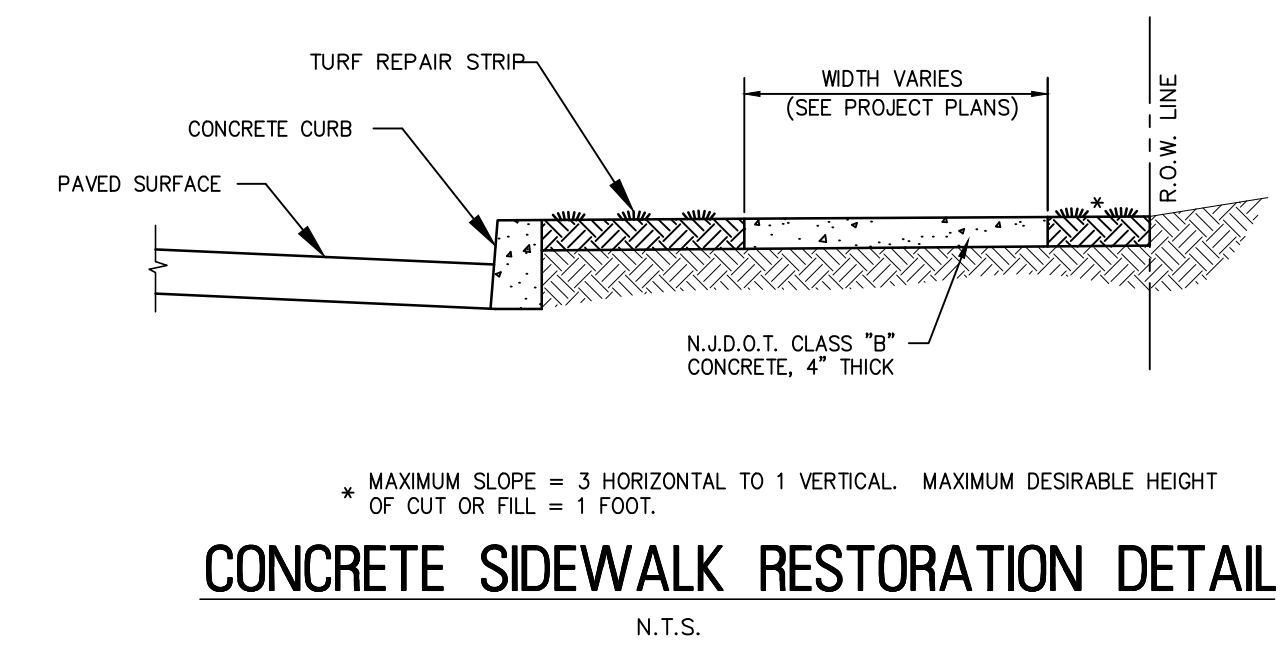

CONCRETE SIDEWALK RESTORATION DETAIL
 N.T.S.

* MAXIMUM SLOPE = 3 HORIZONTAL TO 1 VERTICAL. MAXIMUM DESIRABLE HEIGHT OF CUT OR FILL = 1 FOOT.

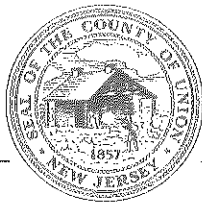

COUNTY OF UNION

DEPARTMENT OF ENGINEERING, PUBLIC WORKS & FACILITIES MANAGEMENT
Joseph A. Graziano Sr., Director

BOARD OF
CHOSEN FREEHOLDERS

ALEXANDER MIRABELLA
Chairman

ANGELA R. GARRETSON

SERGIO GRANADOS

CHRISTOPHER HUDAK

BETTE JANE KOWALSKI

KIMBERLY PALMIERI-MOUEDE

ANDREA STATEN

REBECCA WILLIAMS

EDWARD T. OATMAN
County Manager

AMY C. WAGNER
Deputy County Manager

BRUCE H. BERGEN, ESQ.
County Counsel

JAMES E. PELLETTIERE, RMC
Clerk of the Board

THOMAS O. MINEO, P.E.
*County Engineer,
Director, Division of Engineering*

MEMORANDUM

TO: All Potential Bidders

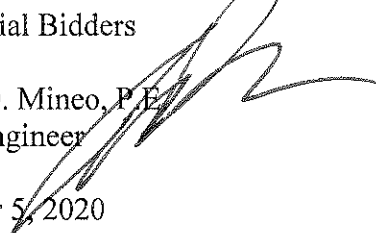
FROM: Thomas O. Mineo, P.E.
County Engineer 

DATE: November 5, 2020

RE: CLARIFICATION - NUMBER 1
Intersection Improvements at South Michigan
Avenue and Quinton Avenue, Borough of
Kenilworth, County of Union, New Jersey
BA# 20-2020,
Union County Engineering Project #2018-012

The attached drawings were inadvertently not included in the bid documents. These drawings are part of the bid documents.

DIVISION OF ENGINEERING



COUNTY OF UNION BOARD OF CHOSEN FREEHOLDERS PLANS FOR INTERSECTION IMPROVEMENTS AT SOUTH MICHIGAN AVENUE AND QUINTON AVENUE UNION COUNTY PROJECT NO. 2018-012



FRANK J. SENEY JR.
L.P.E. PROFESSIONAL ENGINEER, No. 121,222

LIST OF UTILITIES AND EMERGENCY CONTACT INFORMATION	
FIRE DEPARTMENT:	KENILWORTH FIRE DEPARTMENT CHIEF WILLIAM KRUEGER 450 W. 20TH ST. N. J. 07033 908-276-5737
POLICE DEPARTMENT:	KENILWORTH POLICE DEPARTMENT CHIEF JOHN ZAMERMAN 450 W. 20TH ST. N. J. 07033 908-276-5737
PUBLIC WORKS:	KENILWORTH PUBLIC WORKS JOSEPH KANA 450 W. 20TH ST. N. J. 07033 908-276-5737
SEWER:	KENILWORTH PUBLIC WORKS JOSEPH KANA 450 W. 20TH ST. N. J. 07033 908-276-5737
WATER:	NEW JERSEY AMERICAN WATER SHERRY CHARLES 450 W. 20TH ST. N. J. 07033 908-276-5737
ELECTRIC:	PSE&G EDWARD GRAY 450 W. 20TH ST. N. J. 07033 908-276-5737
CABLE:	COMCAST RICH CINGULSING 800 BROADWAY AVENUE UNION CITY, NJ 07080
GAS:	ELIZABETHTOWN GAS GREGORY J. BALINT 300 GREENWICH UNION CITY, NJ 07080 908-242-8530
TELEPHONE:	VERIZON BILL SCHNEIDER 175 PALMIST STREET FREEHOLD, NJ 07728

SHEET #	DESCRIPTION
1	TITLE SHEET
2	ESTIMATE AND DISTRIBUTION OF QUANTITIES
3	GENERAL NOTES
4	LEGEND
5	SIGNALIZATION PLAN
6	SIGNAL & STRIPING PLAN
7	ELECTRICAL PLAN
8	CONSTRUCTION DETAILS
9	SIGNAL TIMING SCHEDULE

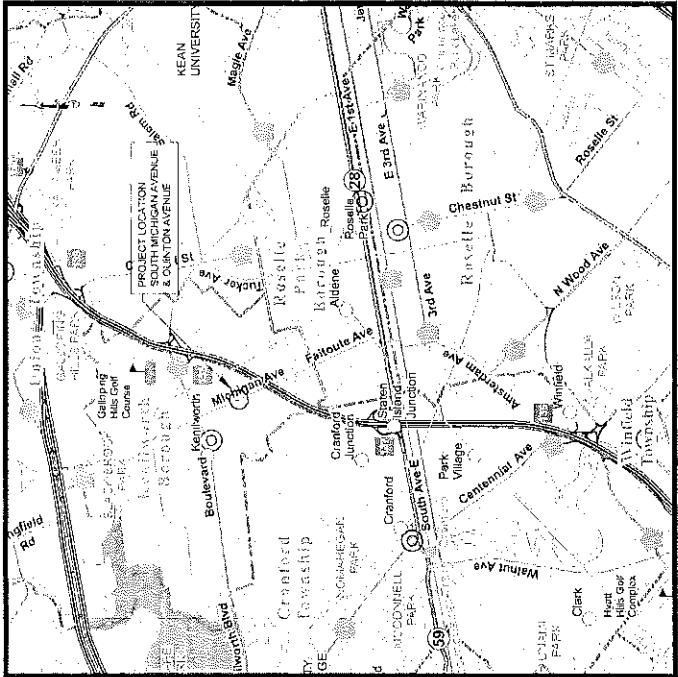

PROJECT LOCATION MAP
NOT TO SCALE

THE BOARD OF CHOSEN FREEHOLDERS OF THE BOROUGH OF KENILWORTH, NEW JERSEY, HAS ADOPTED THESE STANDARD SPECIFICATIONS FOR ROAD AND BRIDGE CONSTRUCTION OF 2007 (A.S. CUSTOMER ENGLISH) AND ALL AMENDMENTS BY THE SUPPLEMENTAL SPECIFICATION "FORM" HERE TO THESE SPECIFICATIONS.
THE NEW JERSEY DEPARTMENT OF TRANSPORTATION, DIVISION OF HIGHWAYS, HAS ADOPTED THESE STANDARD SPECIFICATIONS FOR ROAD AND BRIDGE CONSTRUCTION OF 2007 (A.S. CUSTOMER ENGLISH) AND ALL AMENDMENTS BY THE SUPPLEMENTAL SPECIFICATION "FORM" HERE TO THESE SPECIFICATIONS.
THE NEW JERSEY DEPARTMENT OF TRANSPORTATION, DIVISION OF HIGHWAYS, HAS ADOPTED THESE STANDARD SPECIFICATIONS FOR ROAD AND BRIDGE CONSTRUCTION OF 2007 (A.S. CUSTOMER ENGLISH) AND ALL AMENDMENTS BY THE SUPPLEMENTAL SPECIFICATION "FORM" HERE TO THESE SPECIFICATIONS.

BOROUGH OF KENILWORTH UNION COUNTY, NEW JERSEY

JUNE 2020

TITLE SHEET
INTERSECTION IMPROVEMENTS
SOUTH MICHIGAN AVENUE AND QUINTON AVENUE
UNION COUNTY, NEW JERSEY

APPROVALS

RECOMMENDED FOR APPROVAL BY: HANOR ENGINEERING, A DIVISION OF KENILWORTH ENGINEER DATE: 10/14/2020

APPROVED BY: EDWARD GRAY, P.E., COUNTY ENGINEER DATE: 10/14/2020

APPROVED BY: EDWARD GRAY, COUNTY ENGINEER

1 of 9



REMINGTON & VERNICK ENGINEERS
 330 ONYX HIGHWAY EAST
 SUITE 100
 WASHINGTON, DC 20007
 TEL: (703) 433-1100
 FAX: (703) 433-1101
 WWW.RVE.COM

FRANK J. SENEY JR.
 PE PROFESSIONAL ENGINEER, No. 10322

NO.	REVISION	DATE	BY	CHK

SIGNAGE & STRIPING PLAN

UNION COUNTY
 SOUTH MICHIGAN AVENUE AND QUINTON AVENUE
 INTERSECTION IMPROVEMENTS

PROJECT NO. 1
 SHEET NO. 6 OF 9

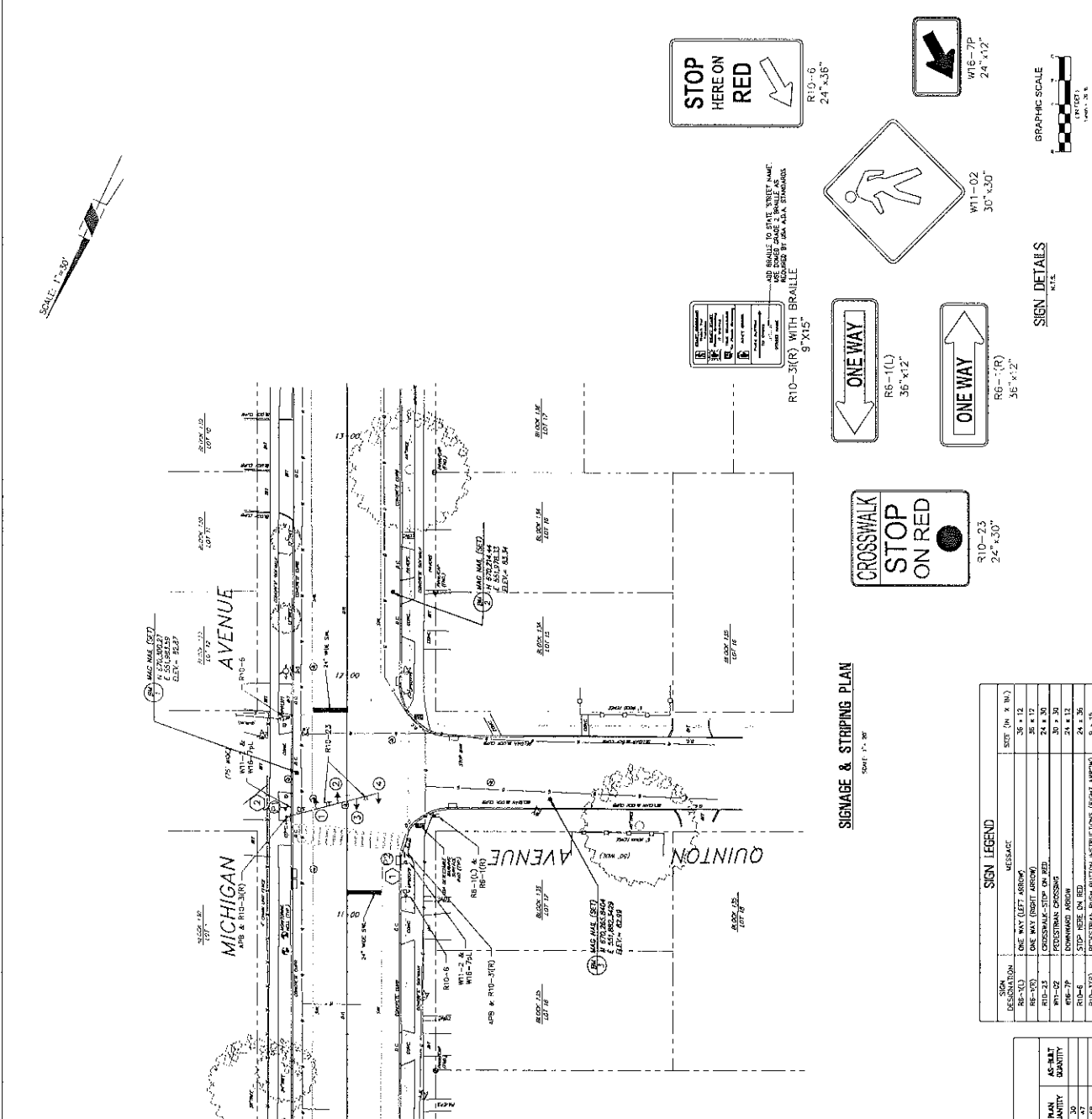

SIGNAL INDICATIONS

1-4
 1-4 LED
 1-4 LED
 1-4 LED
 1-4 LED

3-4-E
 3-4-E
 3-4-E
 3-4-E

TO BE CONSTRUCTED

SIGN LEGEND

SIGN DESIGNATION	MESSAGE	SIZE (W x H)
R10-6	ONE WAY (LEFT ARROW)	36" x 12"
R6-1(L)	ONE WAY (RIGHT ARROW)	36" x 12"
R10-23	CROSSWALK STOP ON RED	24" x 30"
W11-02	PEDESTRIAN CROSSING	30" x 30"
R10-6	STOP HERE ON RED	24" x 36"
R10-3(R)	STOP HERE ON RED WITH BRAILLE	9' x 15'

SIGNAGE & STRIPING PLAN
 SHEET 6 OF 9

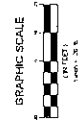

SIGN DETAILS
 N.T.S.

TO BE CONSTRUCTED

ITEM	DESCRIPTION	UNIT	PLAN QUANTITY	AS-BUILT QUANTITY
16	TRAFFIC MARKINGS, LINES, THERMOPLASTIC, 24"	LF	37	37
17	REGULATORY AND WARNING SIGNS	LF	68	68
18	REVISION OF TRAFFIC STRIPES	LF		



FRANK J. SENEY JR.
 PROFESSIONAL ENGINEER, No. 3257

DATE: 10/28/2010
 PROJECT: SOUTH MICHIGAN AVENUE AND QUINTON AVENUE INTERSECTION IMPROVEMENTS
 SHEET: 7 OF 9

NO.	DESCRIPTION	DATE
1	ISSUED FOR PERMIT	10/28/2010
2	AS NOTED	10/28/2010

ELECTRICAL PLAN
 SOUTH MICHIGAN AVENUE AND QUINTON AVENUE
 LAMON COUNTY
 INTERSECTION IMPROVEMENTS
 LAMON COUNTY
 PROJECT NO. 2009-0001
 SHEET 7 OF 9

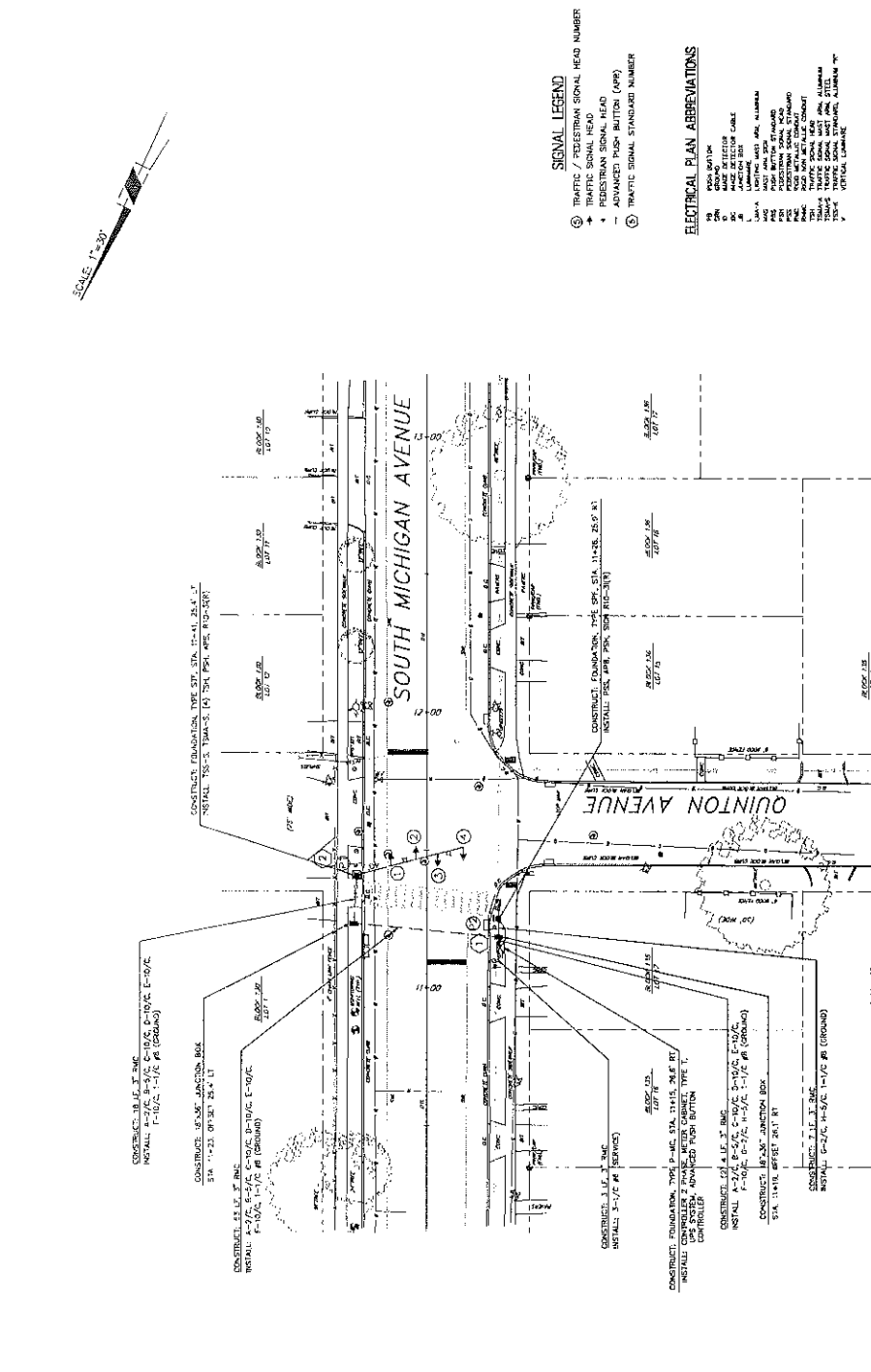
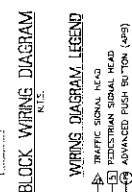
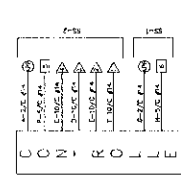
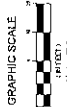
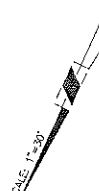

SIGNAL LEGEND
 ① TRAFFIC / PEDESTRIAN SIGNAL HEAD NUMBER
 ▲ TRAFFIC SIGNAL HEAD
 ▼ PEDESTRIAN SIGNAL HEAD
 ◆ ADVANCED PUSH BUTTON (APB)
 ○ TRAFFIC SIGNAL STANDARD NUMBER

ELECTRICAL PLAN ABBREVIATIONS
 18 BOX JOINT
 19 BOX JOINT
 20 PHASE DETECTOR
 21 PHASE DETECTOR CABLE
 22 PHASE DETECTOR CABLE
 23 PHASE DETECTOR CABLE
 24 PHASE DETECTOR CABLE
 25 PHASE DETECTOR CABLE
 26 PHASE DETECTOR CABLE
 27 PHASE DETECTOR CABLE
 28 PHASE DETECTOR CABLE
 29 PHASE DETECTOR CABLE
 30 PHASE DETECTOR CABLE
 31 PHASE DETECTOR CABLE
 32 PHASE DETECTOR CABLE
 33 PHASE DETECTOR CABLE
 34 PHASE DETECTOR CABLE
 35 PHASE DETECTOR CABLE
 36 PHASE DETECTOR CABLE
 37 PHASE DETECTOR CABLE
 38 PHASE DETECTOR CABLE
 39 PHASE DETECTOR CABLE
 40 PHASE DETECTOR CABLE
 41 PHASE DETECTOR CABLE
 42 PHASE DETECTOR CABLE
 43 PHASE DETECTOR CABLE
 44 PHASE DETECTOR CABLE
 45 PHASE DETECTOR CABLE
 46 PHASE DETECTOR CABLE
 47 PHASE DETECTOR CABLE
 48 PHASE DETECTOR CABLE
 49 PHASE DETECTOR CABLE
 50 PHASE DETECTOR CABLE
 51 PHASE DETECTOR CABLE
 52 PHASE DETECTOR CABLE
 53 PHASE DETECTOR CABLE
 54 PHASE DETECTOR CABLE
 55 PHASE DETECTOR CABLE
 56 PHASE DETECTOR CABLE
 57 PHASE DETECTOR CABLE
 58 PHASE DETECTOR CABLE
 59 PHASE DETECTOR CABLE
 60 PHASE DETECTOR CABLE
 61 PHASE DETECTOR CABLE
 62 PHASE DETECTOR CABLE
 63 PHASE DETECTOR CABLE
 64 PHASE DETECTOR CABLE
 65 PHASE DETECTOR CABLE
 66 PHASE DETECTOR CABLE
 67 PHASE DETECTOR CABLE
 68 PHASE DETECTOR CABLE
 69 PHASE DETECTOR CABLE
 70 PHASE DETECTOR CABLE
 71 PHASE DETECTOR CABLE
 72 PHASE DETECTOR CABLE
 73 PHASE DETECTOR CABLE
 74 PHASE DETECTOR CABLE
 75 PHASE DETECTOR CABLE
 76 PHASE DETECTOR CABLE
 77 PHASE DETECTOR CABLE
 78 PHASE DETECTOR CABLE
 79 PHASE DETECTOR CABLE
 80 PHASE DETECTOR CABLE
 81 PHASE DETECTOR CABLE
 82 PHASE DETECTOR CABLE
 83 PHASE DETECTOR CABLE
 84 PHASE DETECTOR CABLE
 85 PHASE DETECTOR CABLE
 86 PHASE DETECTOR CABLE
 87 PHASE DETECTOR CABLE
 88 PHASE DETECTOR CABLE
 89 PHASE DETECTOR CABLE
 90 PHASE DETECTOR CABLE
 91 PHASE DETECTOR CABLE
 92 PHASE DETECTOR CABLE
 93 PHASE DETECTOR CABLE
 94 PHASE DETECTOR CABLE
 95 PHASE DETECTOR CABLE
 96 PHASE DETECTOR CABLE
 97 PHASE DETECTOR CABLE
 98 PHASE DETECTOR CABLE
 99 PHASE DETECTOR CABLE
 100 PHASE DETECTOR CABLE

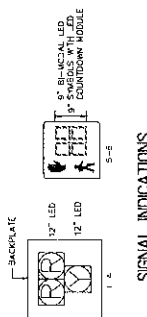

NOTES:
 1. ALL ALUMINUM & STEEL ABOVE GROUND ELECTRICAL EQUIPMENT SHALL BE BLACK POWDER.
 2. CROWNED HEAD INDICATORS SHALL BE BLACK.
 3. INITIAL GROUND WIRE (CROSS) 1/2\"/>

ITEM	DESCRIPTION	UNIT	CONTRACT QUANTITY
1	TRAFFIC SIGNAL HEAD	LN	4
2	TRAFFIC SIGNAL HEAD	LN	4
3	TRAFFIC SIGNAL HEAD	LN	4
4	TRAFFIC SIGNAL HEAD	LN	4
5	TRAFFIC SIGNAL HEAD	LN	4
6	TRAFFIC SIGNAL HEAD	LN	4
7	TRAFFIC SIGNAL HEAD	LN	4
8	TRAFFIC SIGNAL HEAD	LN	4
9	TRAFFIC SIGNAL HEAD	LN	4
10	TRAFFIC SIGNAL HEAD	LN	4
11	TRAFFIC SIGNAL HEAD	LN	4
12	TRAFFIC SIGNAL HEAD	LN	4
13	TRAFFIC SIGNAL HEAD	LN	4
14	TRAFFIC SIGNAL HEAD	LN	4
15	TRAFFIC SIGNAL HEAD	LN	4
16	TRAFFIC SIGNAL HEAD	LN	4
17	TRAFFIC SIGNAL HEAD	LN	4
18	TRAFFIC SIGNAL HEAD	LN	4
19	TRAFFIC SIGNAL HEAD	LN	4
20	TRAFFIC SIGNAL HEAD	LN	4
21	TRAFFIC SIGNAL HEAD	LN	4
22	TRAFFIC SIGNAL HEAD	LN	4
23	TRAFFIC SIGNAL HEAD	LN	4
24	TRAFFIC SIGNAL HEAD	LN	4
25	TRAFFIC SIGNAL HEAD	LN	4
26	TRAFFIC SIGNAL HEAD	LN	4
27	TRAFFIC SIGNAL HEAD	LN	4
28	TRAFFIC SIGNAL HEAD	LN	4
29	TRAFFIC SIGNAL HEAD	LN	4
30	TRAFFIC SIGNAL HEAD	LN	4
31	TRAFFIC SIGNAL HEAD	LN	4
32	TRAFFIC SIGNAL HEAD	LN	4
33	TRAFFIC SIGNAL HEAD	LN	4
34	TRAFFIC SIGNAL HEAD	LN	4
35	TRAFFIC SIGNAL HEAD	LN	4
36	TRAFFIC SIGNAL HEAD	LN	4
37	TRAFFIC SIGNAL HEAD	LN	4
38	TRAFFIC SIGNAL HEAD	LN	4
39	TRAFFIC SIGNAL HEAD	LN	4
40	TRAFFIC SIGNAL HEAD	LN	4
41	TRAFFIC SIGNAL HEAD	LN	4
42	TRAFFIC SIGNAL HEAD	LN	4
43	TRAFFIC SIGNAL HEAD	LN	4
44	TRAFFIC SIGNAL HEAD	LN	4
45	TRAFFIC SIGNAL HEAD	LN	4
46	TRAFFIC SIGNAL HEAD	LN	4
47	TRAFFIC SIGNAL HEAD	LN	4
48	TRAFFIC SIGNAL HEAD	LN	4
49	TRAFFIC SIGNAL HEAD	LN	4
50	TRAFFIC SIGNAL HEAD	LN	4

TO BE CONSTRUCTED

NO.	DATE	REVISIONS

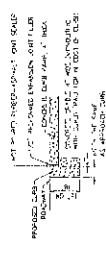

**DROPPED CURB AND CRACKLE AT ALL
PUBLIC SIDEWALK CURB RAMPS**
N.T.S.

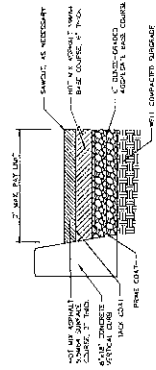

CURB PAVEMENT RESTORATION DETAIL
N.T.S.

NOTE:
1. ALL MATERIALS EXCEPT THE 1 1/2\"/>

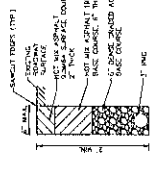

**TRENCH RESTORATION DETAIL
FOR OPEN CUT METHOD**
N.T.S.

NOTE:
1. ALL MATERIALS EXCEPT THE 1 1/2\"/>

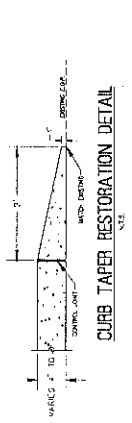

CURB TAPER RESTORATION DETAIL
N.T.S.

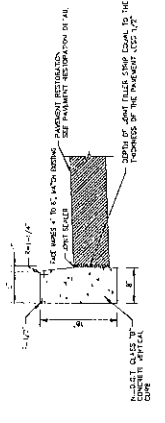

CONCRETE VERTICAL CURB RESTORATION DETAIL
N.T.S.

NOTE:
1. ALL MATERIALS EXCEPT THE 1 1/2\"/>

2. CURB JOINTS (SEAM) SHALL BE INSTALLED UPSTREAM FROM THE
EXPANSION JOINTS.
3. THE CURB SHALL BE FINISHED WITH A 1/2\"/>

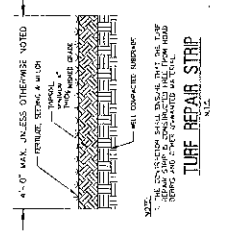

TURF REPAIR STRIP
N.T.S.

NOTE:
1. ALL MATERIALS EXCEPT THE 1 1/2\"/>

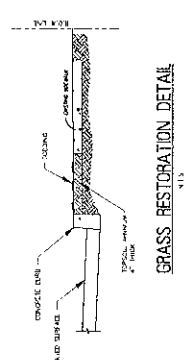

GRASS RESTORATION DETAIL
N.T.S.

NOTE:
1. ALL MATERIALS EXCEPT THE 1 1/2\"/>

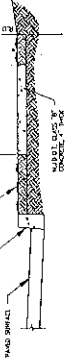

CONCRETE SIDEWALK RESTORATION DETAIL
N.T.S.

NOTE:
1. ALL MATERIALS EXCEPT THE 1 1/2\"/>



REMINGTON & VERNICK ENGINEERS
 1000 WILSON AVENUE
 ANN ARBOR, MI 48106
 PHONE: 734-769-5400 FAX: 734-769-5401
 WWW: WWW.RVE.COM

DATE: 10/11/05
 DRAWING NO.: 10501002
 PROJECT: 10501002
FRANK J. SENEY JR.
 PROFESSIONAL ENGINEER, No. 302

STATE OF MICHIGAN
 DEPARTMENT OF TRANSPORTATION
 DIVISION OF HIGHWAYS
 221 WEST WASHINGTON AVENUE
 LANSING, MICHIGAN 48224-2443
 PHONE: (313) 237-2500 FAX: (313) 237-2501
 WWW: WWW.STATE.MI.GOV

NO.	DATE	REVISION

SIGNAL TIMING SCHEDULE

UNION COUNTY
 INTERSECTION IMPROVEMENTS
 SOUTH MICHIGAN AVENUE AND QUINTON AVENUE
 NEW HENRY
 BRANCH OF NEW HENRY

SCALE:	DRAWN:	CHECKED:	DATE:
DATE PLOTTED:			

9 of 9

TRAFFIC SIGNAL TIMING SCHEDULE





PHASE	1-4	P5, P6	TIME (SEC)
A - SOUTH MICHIGAN AVENUE ROW	DARK	DW	
A - FLASHING CHANGE	FY	DW	3
A - SOLID CHANGE	Y	DW	3
A - CLEARANCE	R	DW	2
B - PEDESTRIAN ROW	R	W	7
B - PEDESTRIAN CLEARANCE	FR	FDW	14
EMERGENCY FLASH	FY	DARK	

W = WALK (SYMBOLIC MAN) FDW = FLASHING DON'T WALK (SYMBOLIC HAND) DW = DON'T WALK (SYMBOLIC HAND) FY = FLASHING YELLOW FR = FLASHING RED

SOUTH MICHIGAN AVENUE & QUINTON AVENUE SIGNAL NOTES:

1. MEMORY CIRCUIT - OFF.
2. MANUAL CONTROL - DISCONNECTED.
3. SIGNAL SHALL REST IN PHASE A - DARK INTERVAL UNTIL PEDESTRIAN ACTUATION.
4. PROVIDE A 30 SECOND DELAY BETWEEN PEDESTRIAN ACTUATIONS.

PHASE LEGEND

-  PROHIBITED VEHICLE MOVEMENT
-  PROTECTED VEHICLE MOVEMENT
-  PERMITTED VEHICLE MOVEMENT
-  PROHIBITED PEDESTRIAN MOVEMENT
-  PROTECTED PEDESTRIAN MOVEMENT

GENERAL NOTE:

1. IN THE CASE OF POWER FAILURE, THE TRAFFIC SIGNAL SHALL OPERATE IN FULL OPERATION MODE FOR FOUR (4) HOURS AND THEREAFTER IN FLASH MODE.

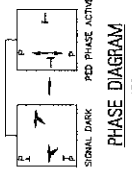

TRAFFIC SIGNAL PHASE DIAGRAM
 SOUTH MICHIGAN AVENUE & QUINTON AVENUE

**SPECIFICATIONS
FOR
INTERSECTION IMPROVEMENTS AT SOUTH MICHIGAN AVENUE &
QUINTON AVENUE, BOROUGH OF KENILWORTH, COUNTY OF UNION,
NEW JERSEY
BA#20-2020; UNION COUNTY ENGINEERING PROJECT #2018-012**

NOVEMBER 2020

**UNION COUNTY OFFICIALS
BOARD OF CHOSEN FREEHOLDERS**

Alexander Mirabella, Chairman
Angela R. Garretson, Freeholder
Sergio Granados, Freeholder
Christopher Hudak, Freeholder
Bette Jane Kowalski, Freeholder
Kimberly Palmieri-Mouded, Freeholder
Andrea Staten, Freeholder
Rebecca Williams, Freeholder

CLERK OF THE BOARD
James E. Pellettiere, RMC

COUNTY MANAGER
Edward T. Oatman

**DEPARTMENT OF ENGINEERING, PUBLIC WORKS AND
FACILITIES MANAGEMENT**
Joseph A. Graziano, Sr., CPWM, Director

**COUNTY ENGINEER
DIVISION OF ENGINEERING**
Thomas O. Mineo, P.E.

PREPARED BY:
REMINGTON & VERNICK ENGINEERS

**COUNTY OF UNION
NOTICE TO BIDDERS**

Sealed bids will be received by the Assistant Director of the Division of Purchasing, or her designee, at the County of Union, New Jersey on December 1, 2020 at 11:30 a.m., prevailing time, in the 6TH Floor Conference Room, U.C. Administration Building, 10 Elizabethtown Plaza, Elizabeth, New Jersey for:

**INTERSECTION IMPROVEMENTS AT SOUTH MICHIGAN AVENUE & QUINTON AVENUE,
BOROUGH OF KENILWORTH, COUNTY OF UNION, NEW JERSEY
BA#20-2020; UNION COUNTY ENGINEERING PROJECT #2018-012**

Bid Packages may be obtained at no charge by registering and downloading at <http://ucnj.org/bid-specs>. Bid Packages may also be obtained in person from the Division of Engineering at 2325 South Avenue, Scotch Plains, New Jersey 07076 between 8:30 a.m. and 4:00 p.m. weekdays upon payment of a non-refundable money order or bank check in the amount of \$275.00 made payable to the County of Union. No Personal / Company checks will be accepted. Requests for mailing of specifications will not be honored. For further information please call 908-789-3675.

The County reserves the right to reject any and all bids and to waive any and all informalities in the bid in accordance with the New Jersey Local Public Contracts Law.

***Public access to the County of Union Administration Building is currently restricted during the statewide public health emergency. Accordingly there will not be an in-person public opening but instead will be conducted live and streamed via the County of Union live streaming platform which will feature both audio and video capabilities. A link will be provided on the day of the opening at <https://ucnj.org/>.

Bids shall be submitted in a sealed envelope and clearly marked with the subject of the bid, name and address of the bidder, phone & fax number, and date of the bid opening. Each bid must be delivered to reach the Division of Purchasing prior to the stated time of the opening of the bids. The County will not be responsible for late delivery by the U.S. Mail or any other carrier. Hand delivery of proposals are strongly discouraged due to public restrictions. If delivered by hand, you will not receive confirmation of delivery. **No** late bids will be accepted.

Bidders are required to comply with the requirements of N.J.S.A. 10:5-31 et seq. and N.J.A.C. 17:27.

***Entire bid packages received will be scanned and available for public inspection on the portal, <http://ucnj.org/itb>, as they would be available for public inspection after an in-person bid opening. Bidders are reminded to review their submissions for any information they consider to be confidential. The County will not be responsible for the release of any information contained in the bid package which may be subject to confidentiality.

MICHELLE HAGOPIAN, ASSISTANT DIRECTOR OF PURCHASING

**UNION COUNTY BOARD
OF CHOSEN FREEHOLDERS**

We're Connected to You!

**INTERSECTION IMPROVEMENTS AT SOUTH MICHIGAN AVENUE & QUINTON AVENUE,
BOROUGH OF KENILWORTH, COUNTY OF UNION, NEW JERSEY**

BA#20-2020; UNION COUNTY ENGINEERING PROJECT #2018-012

TABLE OF CONTENTS

Cover Sheet: County Officials
NB-1: Notice to Bidders

GENERAL SPECIFICATIONS

Definitions

- Section 1: BID FORM
- Section 2: WITHDRAWAL OF BID DUE TO MISTAKE
- Section 3: QUALIFICATIONS OF BIDDERS AND REQUIRED SUBMISSIONS
- Section 4: INTERPRETATIONS AND ADDENDA
- Section 5: OBLIGATION OF BIDDER TO INSPECT SITE AND CONTRACT DOCUMENTS
- Section 6: BID AND PERFORMANCE GUARANTEE
- Section 7: COMMENCEMENT AND COMPLETION
- Section 8: BIDDER AFFIDAVIT
- Section 9: CLASSIFICATION AND QUALIFICATION OF BIDDERS
- Section 10: UNCOMPLETED CONTRACTS (BUILDING PROJECTS ONLY)
- Section 11: LABOR AND MATERIALS
- Section 12: INSURANCE REQUIREMENTS
- Section 13: INDEMNIFICATION REQUIREMENTS
- Section 14: ROYALTIES AND PATENTS
- Section 15: PLANS AND SPECIFICATIONS
- Section 16: GUARANTEE AGAINST DEFECTIVE WORK
- Section 17: TRAFFIC AND STREET MAINTENANCE
- Section 18: CONTRACTOR'S EMPLOYEES
- Section 19: OWNERSHIP DISCLOSURES REQUIRED
- Section 20: NON-COLLUSION AFFIDAVIT
- Section 21: EQUAL EMPLOYMENT OPPORTUNITY COMPLIANCES
- Section 22: COMPLIANCE WITH NEW JERSEY PREVAILING WAGE ACT
- Section 23: BRAND NAME OR EQUAL
- Section 24: LINES AND GRADES
- Section 25: NUMBER OF WORKING DAYS
- Section 26: PROMPT PAYMENT OF CONSTRUCTION CONTRACTS (NJ Prompt Payment Act)
- Section 27: STOPPING WORK ON ACCOUNT OF BAD WEATHER
- Section 28: ACCESS FOR OTHER CONTRACTORS
- Section 29: CONDEMNED MATERIALS AND WORK
- Section 30: STORAGE
- Section 31: FINAL CLEAN UP
- Section 32: SUB-LETTING OF WORK
- Section 33: SAFETY
- Section 34: QUALITY, SAFETY AND PERFORMANCE STANDARDS
- Section 35: MATTERS NOT MENTIONED IN CONTRACT DOCUMENTS
- Section 36: PERMITS
- Section 37: CONTRACTOR TO PROVIDE PROOF OF PAYMENT
- Section 38: CHANGE ORDERS
- Section 39: SUPPLEMENTAL WORK
- Section 40: FORM OF CONTRACT
- Section 41: PROGRESS PAYMENTS
- Section 42: INSPECTION
- Section 43: DAMAGES
- Section 44: LIQUIDATED DAMAGES
- Section 45: AFFIRMATIVE ACTION REQUIREMENTS
- Section 46: INVESTMENT ACTIVITIES WITH IRAN

GENERAL SPECIFICATIONS CONTINUED

- Section 47: COMPLIANCE WITH THE PUBLIC WORKS CONTRACTOR REGISTRATION ACT
(N.J.S.A. 34:11-56.48 et seq)
- Section 48: UTILITIES
- Section 49: MATERIAL COMPLIANCE AND SHOP DRAWINGS
- Section 50: PRECONSTRUCTION
- Section 51: DISPUTES UNDER THE CONTRACT
- Section 52: ORDINANCE NO. 557-2002 ADOPTED ON SEPTEMBER 5, 2002
BY THE BOARD OF CHOSEN FREEHOLDERS
- Section 53: CONTRACTOR BUSINESS REGISTRATION CERTIFICATE
(New Mandatory Requirement – Effective 1/18/2010)
- Section 54: BID PROTEST - LEGAL FEES AND COSTS
- Section 55: AMERICAN GOODS AND PRODUCTS WHERE POSSIBLE
- Section 56: NEW JERSEY PAY-TO-PLAY REQUIREMENTS
- Section 57: STATEMENT OF EQUIPMENT TO BE USED IN CONSTRUCTION
- Section 58: NEW JERSEY SALES AND USE TAX REQUIREMENTS

BIDDING DOCUMENTS

- Bid Document Submission Checklist
- Bidding Documents
- Bid Form
- Consent of Surety
- Bidder Signature Page
- Bidder Disclosure Statement
- Subcontractor Identification Statement: List of Subcontractors
- Subcontractor Identification Certification
- Acknowledgement of Addendum
- Contractor Business Registration Certificate
- Affirmative Action Requirement
- Experience Statement
- Certificate of Bidder Showing Ability to Perform Contract
- Non-Collusion Affidavit
- Contractor Registration Advisement
- Americans with Disabilities Act
- Statement of Bidder's Qualifications
- Contractor Performance Record
- Affidavit Regarding List of Disbarred, Suspended or Disqualified Bidders
- Prior Negative Experience Questionnaire-Certification
- Contractor's Certification of Compliance - New Jersey Prevailing Wage Act
- Uncompleted Contracts Affidavit
- Certificate of Insurance Statement
- Collection of Use Tax on Sales to Local Governments Statement
- Time of Completion
- Disclosure of Investment Activities in Iran Certificate Form

SS - STANDARD SPECIFICATIONS SS-1

STANDARD FORM OF AGREEMENT BETWEEN OWNER AND CONTRACTOR AIA DOCUMENT A-101/2007
(Draft form until contract is awarded)

GENERAL CONDITIONS OF THE CONTRACT FOR CONSTRUCTION AIA DOCUMENT A-201/2007
(Draft form until contract is awarded)

NEW JERSEY PREVAILING WAGE DETERMINATION DOCUMENTS

**UNION COUNTY BOARD OF CHOSEN FREEHOLDERS
INSTRUCTIONS TO BIDDERS AND FORMS**

DEFINITIONS

Wherever reference is made to the County, Title of Project, Bidder, or Vendor/Contractor they shall be as follows:

OWNER/COUNTY:

Union County Board of Chosen Freeholders
UC Administration Building, 6th Floor
10 Elizabethtown Plaza
Elizabeth, New Jersey 07207

ADDRESS INQUIRIES TO:

Union County Division of Purchasing
UC Administration Building, 3rd Floor
10 Elizabethtown Plaza
Elizabeth, NJ 07207
Attn: Michelle Hagopian, Assistant Director, Division of Purchasing
Telephone: 908-527-4130
Facsimile: 908-558-2548
ucbids@ucnj.org

ADDRESS BIDS AND SUBMIT TO:

Union County Division of Purchasing
UC Administration Building, 3rd Floor
10 Elizabethtown Plaza
Elizabeth, NJ 07207
Attn: Michelle Hagopian, Assistant Director, Division of Purchasing
Telephone: 908-527-4130
Facsimile: 908-558-2548
ucbids@ucnj.org

TITLE OF PROJECT:

**INTERSECTION IMPROVEMENTS AT SOUTH MICHIGAN AVENUE & QUINTON AVENUE,
BOROUGH OF
KENILWORTH, COUNTY OF UNION, NEW JERSEY
BA#20-2020; UNION COUNTY ENGINEERING PROJECT #2018-012**

BIDDER: Bidder shall be a single overall contract bidder

ENGINEER: Remington & Vernick Engineers

COUNTY ENGINEER AND/OR CONSTRUCTION MANAGER (as applicable):

COUNTY ENGINEER:

Thomas O. Mineo, P.E.
Union County
Division of Engineering

CONSTRUCTION MANAGER:

GENERAL SPECIFICATIONS

1. BID FORM

Bids for this Work will be enclosed in a sealed envelope addressed to the Purchasing Division, County of Union, New Jersey, Union County Administration Building, 10 Elizabethtown Plaza, Elizabeth, New Jersey 07207, with the full name of the Project clearly marked on the outside. Refer to the sheet marked "Notice of Bid (Advertisement)" for the correct name of the Project. Bidders must submit their bids on the attached pricing sheet (Bid Form), in a sealed envelope addressed to the County and bearing on the outside: the name of the Bidder, Bidder's business address, and the title of the Project.

The Division of Purchasing will receive the bids for this Work at the Union County Administration Building, 10 Elizabethtown Plaza, Elizabeth, New Jersey on the date and time noted on the sheet marked "**Notice of Bid (Advertisement)**".

The County will not assume responsibility for bids forwarded by mail. It is the individual's responsibility to see that the bids are presented to the Purchasing Division at the time and at the place designated.

Bids will be accepted only on the Bid Form supplied. Bids on forms other than the original supplied herein will be rejected. The "complete" Bid Documents includes the Bid Bond, Bid Form, Bidder's Checklist, Consent of Surety, Ownership Disclosure Certification, Non-Collusion Affidavit, and any other documents noted in these Instructions to Bidders or Contract Document to be submitted with this Bid. (See AIA Owner/Contractor Agreement & General Conditions attached.)

The bidder will state in the bidding sheet the price per unit of measure for each scheduled Item of Work for which he will agree to carry out the Work, and the Total Bid Price for the construction of the Project.

The prices in the Bid Form shall be typed or written in pen and ink. Erasures or alterations must be initialed by the bidder in ink.

The bidding sheet for this Project may include a fixed amount as a Bid Allowance. If applicable, all bidders are required to add this fixed amount to their base bid and to include this additional amount in their Bid Bond. This sum will be included in the Contract as well as the performance, labor and materials bond. Payment by the County will be made to the Contractor from these funds only upon the completion of extra Work pursuant to a written Change Order(s) signed by the County's Engineer or his designee and the Contractor, prior to the commencement of such Work. Work commenced prior to written approval by the County shall be done at Contractor's risk. Such payment will only be in the amount agreed to by the parties, in writing in the Change Order(s). See Section 39, Change Orders, of these general specifications for further details.

Refer to Bid Document Submission Checklist for all required documents.

In the event there is a discrepancy between the unit price given and the extended total, the unit price will govern. Any discrepancies will be mathematically adjusted.

Insert applicable alternates, if any have been specified, applicable to the Bidder's Work. All alternates MUST be bid upon. Any Bidder's failure to do so will be deemed a material, non-waivable defect and shall render the bid nonresponsive. The Bidder shall clearly designate whether the change in price is an addition or subtraction, by using either a "+" sign or the word "addition", or in the alternative, a "-" sign or the word "minus". If there is no other change in price, the Bidder shall insert "NC" or "No Charge".

When two or more low bids are equal in all respects, awards will be made according to the provisions of N.J.S.A. 40A:11-6.1(d).

Where unit prices have already been established by the Contract Documents, the Bidder agrees that such unit prices shall prevail. All unit prices, whether filled in by the Bidder or established by the Contract Documents, shall become part of the Contract. No bid will be considered or award made, unless applicable unit prices, as required, are filled in.

The County reserves the right to reject any or all bids and also reserves the right to waive any minor informality or non-material exceptions in the bids.

The County of Union has the right to reject any and all bids from any bidder that is in, or contemplates bankruptcy of any chapter of nature. Said bidder shall notify the County, in writing, of any condition or knowledge of the same.

Conditional bids will not be accepted. Bids may be withdrawn prior to the advertised time for the opening of bids or authorized postponement thereof or in accordance with the provisions of N.J.S.A. 40A:11-23.3 discussed below. Bids received after the advertised time shall not be considered. Bidders shall be solely responsible for premature opening or late delivery of bids not properly marked, addressed, or directed.

2. WITHDRAWAL OF BID DUE TO MISTAKE

N.J.S.A. 40A:11-23.3 authorizes a bidder to request withdrawal of a public works bid due to a mistake on the part of the bidder. A mistake is defined by N.J.S.A. 40A:11-2(42) as a clerical error that is an **unintentional and substantial computational error or an unintentional omission of a substantial quantity of labor, material, or both, from the final bid computation.**

A bidder claiming a mistake under N.J.S.A. 40A:11-23.3 must submit a request for withdrawal, **in writing**, by certified or registered mail to Michele Hagopian, Assistant Director, Division of Purchasing, County of Union, New Jersey, Union County Administration Building, 10 Elizabethtown Plaza, Elizabeth, New Jersey 07207. The

bidder must request withdrawal of a bid due to a mistake, as defined by the law, within five business days after the receipt and opening of the bids. Since the bid withdrawal request shall be effective as of the postmark of the certified or registered mailing, Michele Hagopian, Assistant Director of the Division of Purchasing or his designee may contact all bidders, after bids are opened, to ascertain if any bidders wish to, or already have exercised a request to withdraw their bid pursuant to N.J.S.A. 40A:11-23.3.

A bidder's request to withdraw the bid **shall** contain evidence, including any pertinent documents, demonstrating that a mistake was made. Such documents and relevant written information shall be reviewed and evaluated by the County's designated staff pursuant to the statutory criteria of N.J.S.A. 40A:11-23.3.

The County will not consider any written request for a bid withdrawal for a mistake, as defined by N.J.S.A. 40A:11-2(42), by a bidder in the preparation of a bid proposal unless the postmark of the certified or registered mailing is within the five business days following the opening of bids.

3. QUALIFICATIONS OF BIDDERS AND REQUIRED SUBMISSIONS

The County may make such investigation as it deems necessary to determine the ability of the Bidders to perform the Work, which includes investigation of any and all subcontractors listed with the bid. The Bidder shall furnish any information and data for this purpose as the County may request.

4. INTERPRETATIONS AND ADDENDA

Any explanation desired by a bidder regarding the meaning or interpretation of the Contract Documents must be requested in writing to the Assistant Director, Division of Purchasing at ucbids@ucnj.org with reasonable time allowed for a reply to reach bidders before submission of their bids. Any interpretation or instruction made by the County Engineer will be in the form of an addendum to the Contract Documents or clarification and will be furnished to all prospective bidders. Oral explanations or instructions given before the award of the Contract will not be binding. Bidders are required to bring to the attention of the Assistant Director, Division of Purchasing at ucbids@ucnj.org the discovery of any apparent ambiguity, inconsistency, error, discrepancy, omission in the Contract Documents for interpretation and correction at least ten (10) working days before opening of bids with the exception of Saturdays, Sundays and holidays.

All Addenda issued through the Offices of the County Engineer are amendments to the Contract Documents and shall be considered in preparing bids. Same shall become part of the Contract Documents.

Addenda take precedence over all earlier documents and over each other according to the latest date. Addenda unless themselves interpretive remain subject to interpretation the same as any other document incorporated in the Contract.

Addenda may be issued by the County Engineer up to seven (7) working days prior to the opening of bids. Failure of any bidder to receive an addendum shall not relieve such bidder from the obligation imposed by such addendum. Bidders are to keep themselves currently acquainted with the Contract Documents during the entire bidding period and make inquiry on their own initiative as to issuance of any Addenda. Receipts of all Addenda shall be acknowledged on the “*Acknowledgement of Receipt of Changes*” included in the bid package and must be submitted with the bid.

5. OBLIGATION OF BIDDER TO INSPECT SITE AND CONTRACT DOCUMENTS

At the time of the opening of bids, each Bidder will be presumed to have inspected the site(s) and to have read, and be thoroughly familiar with the Contract Documents. The failure or neglect of any Bidder to receive or examine any form, instrument, or document shall in no way relieve any Bidder from any obligation in respect to its bid.

The Bidder shall examine the contents of the Project Manual and the set of Drawings and assure itself that all pages of the Specifications, Drawings, and other Contract Documents are included in the documents obtained for bidding purposes. Should the Specifications, Drawings, and other Contract Documents be incomplete, the Bidder shall notify the County Engineer in writing, who will supply the Bidder with any missing pages of Specifications, Drawings, or other Contract Documents. The lack of such written notification by the Bidder will be construed as evidence that the Specifications, Drawings, or other Contract Documents supplied it for bidding purposes are full and complete and as a waiver of any subsequent claim to the contrary.

6. BID AND PERFORMANCE GUARANTEE

Each bidder must furnish a Bid Bond, Certified Check or Bank Cashier’s Check in the amount of ten percent (10%) of the Bid. Checks shall be drawn to the order of the County of Union, New Jersey, not to exceed \$20,000.

Each bidder must furnish with the bid a certificate from a Surety Company, i.e. Consent of Surety, stating that in the event of the contract being awarded to said bidder, such Surety Company will provide the Contractor with Bonds guaranteeing the faithful performance of the Work in accordance with the plans and specifications, and the payment for labor, materials, and all other indebtedness which may accrue on the account of this Work. A Performance, Labor and Materials bond will be furnished by the Contractor upon an award of Contract, and will be in the amount of 100% of the contract price.

A one-year Maintenance Bond will be required upon acceptance of the Project by the County in the amount as stated in Section 17 of the General Specifications. Bonds will be written by a firm authorized to issue the bonds under the laws of the State of New Jersey and be in a form acceptable to the County Counsel.

N.J.S.A. 40A:11-1 et seq. allows the prime Contractor to furnish the Performance Security for his Subcontractors. The County of Union requires Performance Security to be furnished by the prime contractor for the entire job in the total amount of the contract.

The County will return all certified checks or cashier's checks after the proposals have been opened, tabulated and reviewed except those of the three (3) bidders lowest responsible bidders. The County will return the checks of these bidders when a contract is awarded to the successful bidder within ten (10) days after the award of the contract.

If the successful bidder refuses or neglects to sign an agreement and furnish the required bonds, the Bid Bond will be held and used by the County to offset any damages for such refusal or neglect.

7. COMMENCEMENT AND COMPLETION

Work will not commence until a Notice to Proceed is received from the County Engineer.

Upon substantial completion of the Project, the Contractor must request a joint inspection with the County Engineer. Upon completion of this inspection, the County Engineer will prepare a list of incomplete or incorrect items (punch list) and have Contractor initial and date same. The Contractor shall rectify all deficiencies noted on the punch list within 30 calendar days of receipt of the list. The County Engineer may approve extensions for extenuating circumstances.

8. BIDDER AFFIDAVIT

All Bidders are required to complete, sign, and submit with their Bid, the attached "Affidavit Regarding List of Debarred, Suspended or Disqualified Bidders". (See form enclosed)

9. CLASSIFICATION AND QUALIFICATION OF BIDDERS

Pursuant to Ordinance Number 557-2002 as adopted by the County on September 5, 2002, all bidders on contracts for public works shall be classified and qualified in accordance with N.J.S.A. 40A:11-25 as well as N.J.S.A. 52:35-1 et seq. (See Section 53 of the General Specifications)

This provision shall not apply to subcontractors.

10. UNCOMPLETED CONTRACTS (BUILDING PROJECTS ONLY)

G-6

Revised: 2020.03.03

The Bidder shall submit a current Classification/Prequalification Certificate and accompanying form(s) indicating the dollar amount of uncompleted contracts, and a notarized and itemized list of these uncompleted contracts in the form provided, with their bid. (See form enclosed)

11. LABOR AND MATERIALS

The prices will cover all costs of any nature incident to and growing out of the Work, including all labor, material, equipment, transportation, loss by damage or destruction of the Project, settlement of damages, and for replacement of defective work or materials. N.J.S.A. 54:32B-1 et seq. exempts all materials sold to the County of Union from sales or use taxes and should not be included in the prices provided on the Bidding Sheet.

12. INSURANCE REQUIREMENTS

The County of Union requires all contractors to be able to comply with the following insurance requirements. In the event a bid is accepted by the County, the contractor must accept the applicable insurance requirements, as set forth below, as part of any contract awarded to it by the County.

Contractor shall carry and maintain at all times while the contract is in full force and effect, the following insurance coverage with an insurance company or companies acceptable to the County, with limits not less than those shown below. A Certificate of Insurance, shall be filed with the County prior to commencement of any Work indicating the following:

- a) Commercial General Liability (CGL): Coverage for all operations including, but not limited to, contractual, products and completed operations, and personal injury with limits no less than \$5,000,000 per occurrence/\$10,000,000 aggregate. The County of Union, its Board of Chosen Freeholders, officers, employees, agents and servants shall be included as an additional insured. Coverage is provided on a primary and on-contributory basis to the County of Union, et al.
- b) Automobile Liability: Coverage for all owned, non-owned and hired vehicles with limits not less than \$5,000,000 per occurrence, combined single limits (CSL) or its equivalent.
- c) Workers Compensation: As required by the State of New Jersey and Employers Liability with limits not less than \$1,000,000 per accident for bodily injury or disease.
- d) Professional Liability (if design/build): Coverage with limits not less than \$1,000,000 per occurrence or claim, \$2,000,000 aggregate

- e) Contractor's Pollution Legal Liability and/or Asbestos Legal Liability and/or Errors & Omissions (if project involves environmental hazards): Coverage with limits no less than \$1,000,000 per occurrence or claim/\$2,000,000 aggregate.
- f) Builders Risk (for major renovations): During the course of construction utilizing an "All Risk" coverage form with limits equal to the completed value of the project and no coinsurance penalty provisions.

Where applicable, a waiver of subrogation in favor of the County of Union, its Board of Chosen Freeholders, officers, employees, agents, servants and the State of New Jersey is to be included in those policies of insurance where permitted by law.

Notice of Cancellation: Each insurance policy required above shall provide that coverage shall not be canceled, except with notice to the Entity.

Special Risks or Circumstances: The County reserves the right to modify these requirements, including limits, based on the nature of the risk, prior experience, insurer, coverage, or other special circumstances.

13. INDEMNIFICATION REQUIREMENTS

The County of Union requires all bidders to accept the following indemnification requirements in the event the County accepts their bid. The Contract awarded by the County to the successful bidder will contain the following provision:

"To the fullest extent permitted by law the Contractor shall indemnify and hold harmless the owner and the owner's consultants, agents, representatives, and employees from and against any and all claims, damages, losses, costs, and expenses, including, but not limited to attorneys' fees, legal costs and legal expenses arising out of or resulting from the performance of the Contractor's work under this contract, provided that such claim, damage, loss, cost, or expense is attributable to bodily injury, sickness, disease or death, or to injury to or destruction of tangible property (other than the work itself) caused or alleged to be caused by the negligent acts, negligent omissions, and/or fault of the Contractor, anyone directly or indirectly employed or retained by the Contractor, or anyone for whose acts the Contractor may be liable regardless of whether caused in part by the negligent act or omission of a party indemnified hereunder provided it is not caused by the sole negligence of a party indemnified hereunder. Contractor shall further indemnify and hold harmless the County and the County's consultants, agents, representative, and employees from and against any and all claims, damages, losses, costs, and expenses, including, but not limited to attorneys' fees, legal costs and legal expenses, arising out of or resulting from performance of the work, provided that such claim, damage, loss, cost, or expense is attributable to bodily injury, sickness, disease or death, or to injury to or destruction of tangible property (other than the work itself) caused or alleged to be caused by the negligent acts,

negligent omissions, and/or fault of the County or the County's consultants, agents, representatives, or employees and arises out of this project and provided such claim, damage, loss, cost, or expense is not caused by the sole negligence of a party indemnified hereunder."

14. ROYALTIES AND PATENTS

The Contractor shall pay all royalties and license fees. He shall defend all suits or claims for infringement of any patent rights and shall hold the County harmless from loss on account thereof.

15. PLANS AND SPECIFICATIONS

In carrying out the Work, the plan(s) and the specifications will be followed by the Contractor. Minor alterations in the plan may be made or permitted by the County Engineer from time to time and, if no additional Work is necessary, there will be no additional charge for carrying out such minor alterations.

The Contractor shall provide the County Engineer a set of reproducible as-built drawings upon completion of the Project. The Contractor shall maintain an updated construction progress plan in the Project field office at all times.

When applicable, The New Jersey Department of Transportation Standard Specifications for Road and Bridge Construction, as amended, and Supplemental Specifications for State Aid Projects, herein after referred to as the "Standard Specifications", are made a part of these specifications and contract for the improvements, and will govern the construction of this Project, the material used and the execution of this Project, except as revised and modified herein. The references to these specifications are given herein for the purpose of aiding in the rapid location of the description of the various items herein specified. The entire Work must be carried on and completed to the satisfaction of the County. The Standard Specifications are amended as follows:

"Any reference to the Commissioner, Department, Department Laboratory, Engineer or Inspector should be redefined to be the County of Union".

16. GUARANTEE AGAINST DEFECTIVE WORK

Prior to final payment being made or before the release of the performance security required by Section 3 above, the Contractor and Surety shall execute and deliver to the County an original Maintenance Bond with an original signature and seal having a penal sum equal to:

- A) One hundred percent (100%) of the final adjusted Contract amount, if such amount is \$50,000.00 or less;

- B) Fifty percent (50%) of the final adjusted Contract amount, if such amount be greater than \$50,000.00 but less than \$250,000.00; and,
- C) Twenty-five percent (25%) of the final adjusted contract amount, if such amount is \$250,000.00 or more.

The Bond and Surety shall be satisfactory to the Union County Counsel. The Surety shall hold a Certificate of Authorization to do business in the State of New Jersey and shall conform to P.L. 1995 c.384, codified as N.J.S.A. 2A: 44-143, 144. The Surety Disclosure Statement and Certification required by N.J.S.A. 2A: 44-143, 144, shall be attached to the Bond. Such Maintenance Bond shall remain in full force and effect for a period of one (1) year from the date of Final Completion. Such Maintenance Bond shall also provide that the Contractor and the Surety guarantee to replace for the said period of one (1) year from the date of Final Completion, all Work performed and/or all materials furnished that were not performed or were not furnished in accordance to the terms and performance requirements of the Contract Documents, and will make good any defects thereof which become apparent before the expiration of one (1) year. If, during that period, any part of the Project, in the judgment of the Engineer, is found defective, the Contractor will repair or replace same within five (5) days of receipt of notice from the County Engineer. If the Contractor refuses or neglects to do such Work in the time specified, the County Engineer may have the Work done by others and the Contractor or his Surety thereof will pay the cost.

The Contractor will furnish the County a Maintenance Bond for a percentage of the final adjusted contract price, as stated above. The one (1) year period will start the day of Final Completion of Project by the County. Final payment is conditional on the receipt of a maintenance bond in a form acceptable to County Counsel.

17. TRAFFIC AND STREET MAINTENANCE

The Work must be started and performed by the Contractor in such a manner as to minimize delays to the traveling public. It must be completed in a timely fashion, with little or no inconvenience to traffic and pedestrians, where such inconvenience may be avoided.

All municipal, county, and state roadways shall remain open to traffic unless otherwise provided for in the technical specifications.

If modified traffic patterns are authorized in order to provide a safe working or traveling environment, the Contractor is responsible for providing all equipment, barrels, cones, signs, and barricades to implement the work zone and detours, unless otherwise specified in the technical specifications. All work zones and detours shall be established in accordance with the technical plans and specifications if provided or in strict compliance with the current version of the Manual for Uniform Traffic Control Devices

(MUTCD). The Contractor shall obtain approval for these work zones and detour plans from the Municipal Police or applicable police agency and the Union County Bureau of Traffic Maintenance prior to implementation.

All traffic control plans shall provide for safe movement of vehicular, bicycle, and pedestrian traffic. Particular attention shall be given to requirements of the Americans with Disabilities Act.

No portion of any street or alleyway may be used for the storage of any materials or equipment without the approval of the Municipal Police or other applicable police agency. Sidewalks, gutters, drains, fire hydrants and private drives shall be maintained for their intended use unless specifically approved by the County Engineer.

Upon suspension of Work, at the end of the day or for protracted periods, the Contractor shall remove all rubbish and materials from the Work site to the approved storage/staging location. All road cuts, saw cuts, and trenches that may pose hazard to vehicular, pedestrian, or bicycle traffic, to include handicapped users, shall be filled to the surface of the roadway or sidewalk. At no time will steel plates or settled trenches be allowed at the daily suspension of Work, unless specifically approved by the County Engineer.

Use of Traffic Control Officers shall be determined by the County in accordance with the provisions of N.J.S.A. 40A:11-23.1(c). If applicable to the Project, the County shall have provided an allowance for same as set forth in the Bid Form.

With respect to pedestrian traffic, the Contractor shall install signs restricting access of the general public and, as necessary, Union County employees to the area of construction. The Contractor shall provide safe access to required areas and place physical barriers to restricted areas. These barriers may range from caution tape to actual barriers, at the direction of the County Engineer.

18. CONTRACTOR'S EMPLOYEES

The Contractor must employ only suitable and competent labor in the Work, and must remove from the Work any incompetent, unsuitable, or disorderly person upon complaint from the County Engineer.

The parties to any contract resulting from this proposal do hereby agree that the provisions of N.J.S.A. 10:2-1 through 10:2-4 (discrimination in employment on public works contracts): 34:11-56.25 et seq. (payment of prevailing rate of wages determined pursuant to N.J.S.A. 34:11-56.30 by the Commissioner), and the Rules and Regulations promulgated pursuant thereto, are hereby made a part of any contract and are binding upon them.

There will be no discrimination against any employee who is employed in the Work to be covered by any contract resulting from this bid because of age, race, creed, color, national origin, ancestry, marital status or sex.

Any person, firm, or corporation violating the provisions of this Section will be deemed and judged a disorderly person.

19. OWNERSHIP DISCLOSURES REQUIRED

Pursuant to P.L. 2016, c. 43, codified as N.J.S.A. 52:25-24.2, no corporation, partnership, or limited liability company shall be awarded any contract nor shall any agreement be entered into for the performance of any work or the furnishing of any materials or supplies the County unless prior to the receipt of the bid or accompanying the bid, of said corporation, said partnership, or said limited liability company there is submitted a statement setting forth the names and addresses of all stockholders in the corporation who own ten percent (10%) or more of its stock, of any class, or of all individual partners in the partnership who own a ten percent (10%) or greater interest therein, or of all members in the limited liability company who own a ten percent (10%) or greater interest therein, as the case may be. If one or more such stockholder or partner or member is itself a corporation or partnership or limited liability company, the stockholders holding ten percent (10%) or more of that corporation's stock, or the individual partners owning ten percent (10%) or greater interest in that partnership, or the members owning ten percent (10%) or greater interest in that limited liability company, as the case may be, shall also be listed. The disclosure shall be continued until names and addresses of every non corporate stockholder, and individual partner, and member, exceeding the ten percent (10%) ownership criteria has been listed.

To comply with this section, a bidder with any direct or indirect parent entity which is publicly traded may submit the name and address of each publicly traded entity and the name and address of each person that holds a ten percent (10%) or greater beneficial interest in the publicly traded entity as of the last annual filing with the federal Securities and Exchange Commission ("SEC") or the foreign equivalent, and, if there is any person that holds a ten percent (10%) or greater beneficial interest, also shall submit links to the websites containing the last annual filings with the federal SEC or the foreign equivalent and the relevant page numbers of the filings that contain the information on each person that holds a ten percent (10%) or greater beneficial interest. (See forms attached)

20. NON-COLLUSION AFFIDAVIT

The Bidder shall submit with its bid either the attached completed "Non-Collusion Affidavit" or a statement of non-collusion with verbiage similar to same.

G-12

Revised: 2020.03.03

21. EQUAL EMPLOYMENT OPPORTUNITY COMPLIANCES

The successful bidder shall be required to complete and submit an Initial Project Workforce Report, New Jersey Department of Treasury Form AA-201, upon notification of award. Failure to submit this completed form may result in the Contract being terminated.

The successful bidder shall also be required to submit a copy of its Monthly Project Workforce Report, New Jersey Department of Treasury Form AA-202, to the New Jersey Department of Treasury's Division of Public Contracts Equal Employment Opportunity Compliance and to the Board.

22. COMPLIANCE WITH NEW JERSEY PREVAILING WAGE ACT

The County of Union, in order to fulfill the requirements of N.J.S.A. 34:11-56.25 et seq, requires that the following additional conditions be strictly followed. The bidders represent that he is not listed or is not on record in the Office of the Commissioner or the Department of Labor and Workforce Development as one who failed to pay prevailing wages in accordance with the provisions of this Act. The bidder agrees to the inclusion of a contract provision upon award which specifically requires said Contractor to fully comply with each and all of the requirements of the aforesaid Act as it relates to prevailing rates of wages on public contracts as set forth in the New Jersey Prevailing Wage Act, P.L. 1963, Chapter 150 and P.L. 1974, Chapter 64.

A Copy of the Prevailing Wage Rates is attached for your reference. Applicable rates are those wages and fringe benefit rates in effect on the date the contract is awarded. All predetermined rate increases listed at the time the contract award must also be paid, beginning on the dates specified. Rates may change between the time of issuance of this determination and the award of the public works contract. Therefore, prior to the award of the contract, verification must be made with the Public Contracts section, to insure that the rates contained in this determination are still prevailing.

The Contractor agrees to abide and be bound by each and all of the said statutory provisions with respect to the payment of prevailing rates of wages, and acknowledges that the County reserves the right to terminate the Contractor's (or his subcontractors') right to proceed with the scope of Work, or such portion thereof that relates to the failure to pay prevailing rates of wages. In such event or under the terms of N.J.S.A. 34:11-56.27, the Contractor and his surety will be liable to the County of Union for any excess costs occasioned by such a violation.

The Contractor or subcontractors for this Project will post the Prevailing Wage Rates for each craft and classification involved as determined by the Commissioner of Labor and Industry, including the effective date of any changes thereof, in prominent and

easily accessible places at the site of the Work or at such place or places as are used by them to pay workmen their wages.

The County of Union requires a copy of payroll records from the Contractor and subcontractors. Payroll records shall be submitted with each voucher request for payment. Prevailing wage rates may be obtained from the New Jersey Labor, Division of Workplace Standards, Public Contracts Section, (609-292-2259).

UNION LABOR IS PREFERRED ON ALL COUNTY WORK

The foregoing reference to specific laws will not be deemed to be a limitation of obligation of the Contractor to perform his obligations in full compliance with the provisions and requirements of all federal and state statues and local ordinances applicable to the Work to be done under the contract.

It is agreed and understood that any contracts and/or orders placed as a result of this proposal will be governed and construed and the rights and obligations of the parties hereto will be determined in accordance with the laws of the State of New Jersey.

Upon completion of the Work, the Contractor will furnish a Certification of Compliance with the New Jersey Prevailing Wage Act. The certificate in a form acceptable to County Counsel is a condition of the final payment. (See form attached)

23. BRAND NAME OR EQUAL

When the Specifications, Forms, and other Contract Documents use “brand name or equivalent” or similar language, the listed brand name shall serve as a reference or point of comparison for the functional or operational characteristic desired for the goods or services being requested. Where a bidder attempts to submit an equivalent product for a brand name, it shall be the responsibility of the bidder to fully describe and document the product to be provided with the bid in order to establish the equivalence claim.

- A. If the Bidder proposes to offer substitute goods as an equal to those specified herein, the bidder shall so indicate with the Bid Proposal. For the purposes of this paragraph, a proposed item shall be considered equal to goods specified herein if:
 - 1. The County, in its sole discretion, determines that: (i) the goods conform substantially, even with deviations, to the brand name goods specified herein; (ii) the goods are equal to or greater than the brand name goods specified herein in terms of quality, durability, functionality, appearance, strength and design; (iii) the goods are capable, at least as well as the brand name goods

specified herein, or performing with existing equipment; and (iv) the goods do not cost the County more than the brand name goods specified herein costs the County.

- B. To offer substitute goods as an equal to those specified herein, it is necessary that:
1. The Bidder submits sufficient information with its bid to permit the County to determine that the goods are equivalent to the brand name goods specified herein, including, but not necessarily limited to the brand, catalog number and specifications/data sheets;
 2. The Bidder fully identifies and describes the variations of the goods from the brand name goods specified herein on a separate sheet that is to be submitted with the bid proposal. Bidder's literature WILL NOT suffice in explaining exceptions to these specifications.
 3. The Bidder certifies that the goods (i) are similar in substance to the brand name goods specified, and (ii) are suited to the same use as the item specified;
- C. The County shall be allowed a reasonable time within which to evaluate the Bidder's proposal to offer substitute goods as an equal to those specified herein. The County shall be the sole judge of acceptability. No "or-equal" goods shall be ordered, delivered, assembled, set-up or utilized until the County's evaluation is complete. The County's determination as to equivalency shall be deemed final and absolute.

In the event the Bidder does not provide sufficient supporting documentation with the bid, it will be presumed and required that the brand name goods and services as described in the specifications will be provided.

24. LINES AND GRADES

Normally, horizontal and vertical control points will be provided in the technical specifications. All other surveying will be the responsibility of the Contractor unless otherwise noted.

25. NUMBER OF WORKING DAYS

In accordance with N.J.S.A. 40A:11-17, the Work for the within Project shall be completed as specified on the Time of Completion Form. See form attached.

G-15

Revised: 2020.03.03

There shall be taken a deduction from the contract price, or any wages paid by the County, to any inspector(s) necessarily employed by it on the Work, for any number of days in excess of the number allowed in the specifications.

26. PROMPT PAYMENT OF CONSTRUCTION CONTRACTS (NJ Prompt Payment Act)

Pursuant to N.J.S.A. 2A:30A-1 et seq., payment to the Contractor, other than for Work done pursuant to a contact allowance, where applicable, shall be processed and paid as follows:

1. All contractor bills shall be either approved for payment, or notice provided as to why the bill or any portion of it will not be approved by the representative(s) of the governing body no later than the public meeting following 20 calendar days of the billing date as defined in the statute.
2. If the billing is approved, said bill shall be paid in the payment cycle following the meeting.

27. STOPPING WORK ON ACCOUNT OF BAD WEATHER

Work must only be performed in weather suitable for the type of construction planned or underway. Extremes in temperature, humidity, precipitation, evaporation, etc. can detrimentally affect the constructed product. Refer to the Standard and Technical Specifications for specific items.

28. ACCESS FOR OTHER CONTRACTORS

The Contractor for this Work will give proper access to other contractors who may be employed upon the Project and must not hinder or delay unnecessarily any Work that may be progressing under other contracts.

29. CONDEMNED MATERIALS AND WORK

Any materials and or part of the Work that may be condemned by the County Engineer will be removed and replaced by the Contractor or otherwise rectified, as may be directed by the County Engineer. No payment will be made upon the Work until such faulty work has been made good as may be directed. In the event the Contractor refuses or neglects to make good such faulty work, he will be deemed to have abandoned the contract and proceedings may be taken against him as provided herein.

30. STORAGE

In the event that it is necessary for the Contractor to stockpile or store materials or equipment on the job site, the Contractor shall inform the County of such necessity and the County may offer available space, if any, for storage of such materials or equipment. The Contractor shall use said space only for such purpose. Any and all materials which may be stored in such space or which may be brought onto the job site at any time by the Contractor will be at the Contractor's sole risk. The County will not be responsible for loss of or damage to said materials or equipment for any cause whatsoever. The Contractor shall take necessary measures to protect any such storage area and shall be responsible for any and all damages.

31. FINAL CLEAN UP

Upon completion of the Work, the Contractor will remove all equipment, unused materials, rubbish, etc., and will repair, or replace in an a manner acceptable to the County Engineer, all areas that may have been damaged in the prosecution of the Work. Same shall be a condition precedent to final payment. Should said Contractor fail to comply with this requirement, the County shall undertake the clean-up with its own forces and charge the cost of same against the Contractor's contract balance.

32. SUB-LETTING OF WORK

Except for the List of Subcontractors, pursuant to N.J.S.A. 40A:11-16 (See form attached), no portion of the Work will be sublet by the Contractor to any other entities, except with the consent of the County Engineer. A complete list of subcontractors must be submitted to the County Engineer at the preconstruction meeting. If the job does not warrant a preconstruction meeting, the Contractor must submit such list prior to the start of Work.

All Subcontractors will be subject to N.J.S.A. 34:11-56 et al.

N.J.S.A. 40A:11-16 requires the bidder to list in the bid sheets the name or names of all subcontractors involved in the following types of Work: plumbing and gas fitting and all kindred work, steam and hot water heating, ventilating apparatus, steam power plants and kindred work, electrical work, ornamental iron work, and structural steel. In addition, the County may require the identification of specific additional subcontractors. If these trades are expected to be part of the contract, such subcontractors should be listed on the "Subcontractor Identification Statement List of Subcontractors" and Bidder shall certify same on the accompanying sheet titled "Subcontractor Identification Certification". (See forms attached) **Bidder's failure to submit these two forms shall be considered a material defect and result in rejection of Bidder's bid.** Substitutions of any listed subcontractors pursuant to N.J.S.A. 40A:11-16 will not be permitted except with the consent of the County Engineer.

33. SAFETY

The Contractor shall observe all rules and regulations of the Federal, State, and local health officials. Attention is directed to Federal, State, and local laws, rules, and regulations concerning construction safety and health standards. The Contractor shall not require any worker to work in surroundings or under conditions that are unsanitary, hazardous, or dangerous to the worker's health or safety.

The Contractor shall admit to the site, without delay and without the presentation of an inspection warrant, any inspector of OSHA or other legally responsible agency involved in safety and health administration upon presentation of proper credentials.

The Contractor shall make available to the Contractor's employees, subcontractors, the County Engineer, and the public, all information pursuant to OSHA 29 CFR Part 1926.59 of The Hazard Communication Standard 29 CFR 1910.1200, and shall also maintain a file on each job site containing all Material Safety Data Sheets (MSDS) for products in use at the Project. These Material Safety Data Sheets shall be made available to the Engineer upon request.

The Contractor shall at all times conduct the Work to provide for the safety and convenience of the general public and protection of persons and property. The safety provisions of applicable laws, OSHA regulations, building and construction codes, and the rules and regulations of the New Jersey Department of Labor and Workforce Development shall be observed.

34. QUALITY, SAFETY AND PERFORMANCE STANDARDS

All goods and services must be constructed and provided with the highest quality materials and workmanship. It is the intent of these specifications that only equipment equal to, or exceeding, the standard specified will be acceptable in order to protect the safety of the occupants of the Building.

35. MATTERS NOT MENTIONED IN CONTRACT DOCUMENTS

Any Work, material, or method, not specifically described in these specifications, but shown upon the plans of the Work, will be carried out as shown on said plan.

36. PERMITS

The Contractor will obtain all necessary permits required by law and provide the County with necessary approvals prior to commencement of permitted Work.

37. CONTRACTOR TO PROVIDE PROOF OF PAYMENT

Upon the completion of the Work, the Contractor will furnish a General Release as proof that all claims for labor, materials, etc., have been settled by the Contractor. The General Release, in a form acceptable to County Counsel, is a condition of final payment.

38. CHANGE ORDERS

The applicability of change orders and change order procedures shall comply with *N.J.S.A. 40A:11-16.7* and *N.J.A.C. 5:30-11.1 et seq.*, "Change Orders and Open End Contracts".

39. SUPPLEMENTAL WORK

In case any supplemental work is necessary, it will be performed by the Contractor at a price fixed by agreement between the Contractor and the County Engineer and approved by the County as specified in Section 39. The Contractor will do no supplemental work on any character, for which the Contractor will demand pay, except upon the written order of the County.

40. FORM OF CONTRACT

Contracts will be let on the attached Form of Agreement Between County ("Owner") and Contractor (AIA 101), and General Conditions (AIA 201), as supplemented.

The Contract will be subject to all statutory provisions on the matter of Public Works, Public Contracts, The Law Against Discrimination, the Laws Governing Affirmative Action and Prevailing Rates of Wages under the laws of New Jersey.

The Agreements shall be executed by both parties not later than twenty-one (21) days from the date of the award by the County (Sundays and holidays excluded); however, such time frame may be extended by agreement of the parties.

41. PROGRESS PAYMENTS

Monthly progress payments will be made based on the value of labor and materials incorporated in the Work and of materials suitably stored at the site. An itemized schedule of values shall be submitted with each Application for Payment.

(Refer to the Owner/Contractor Agreement for Retainage and other conditions pertaining to payment and the application of *N.J.S.A. 2A:30A-1 et seq.*)

All Applications for Payment shall be accompanied by paid invoices for materials incorporated in the Work and for materials suitably stored at the site, and affidavit(s) by Subcontractors whose Work was included in the next to the last application to the effect such Work and such materials have been paid for.

No payment shall be made without Contractor having provided all submittals set forth in this Section and the approval of same by the County.

For contracts exceeding \$100,000.00, monthly payments will be made on the Work to the extent of 98% of the value of the Work done which is considered to be retainage.

For contracts less than \$100,000.00, monthly payments will be on the Work to the extent of 90% of the value of the Work done. In lieu of the retainage, the Contractor will, at his option, deposit with the County Counsel negotiable bearer bonds of the State of New Jersey or any political subdivision thereof, equal to the amount otherwise withheld as retainage.

When the Project is completed, the final cost of the Project will be based on actual quantities of authorized Work done under each item scheduled in the bidding sheet and approved Change Orders, if any. The money due to the Contractor as determined by said final certificate after deduction of previous monthly payments on account, will be paid to the Contractor in accordance with the terms of the contract dealing with Prompt Payment, providing, however that before such final payment is made, all outstanding claims against the Contractor must be satisfied. Before final payment is released, the Contractor must furnish: **a)** Maintenance Bond (see Section 17 of these general specifications); **b)** Certification of Compliance, New Jersey Prevailing Wage Act (see Sections 23 & 53); and **c)** General Release (see Section 38) in a form satisfactory to County Counsel; **d)** complete set of as-built plans in the latest AutoCad on compact disc; and **e)** a complete set of in-progress photos in jpg, jpeg, or bmp digital format on a compact disc.

42. INSPECTION

The Work must be done in accordance with the plans and specifications, and will be inspected by the County Engineer. An inspector may be placed upon the Work at any time by the County Engineer to see that the plans, specifications, and instructions of the County Engineer are carried out. In connection herewith, bidders are referred to N.J.S.A. 40A:11-17.

43. DAMAGES

The Contractor will be held responsible for all damages that may occur to Work, or to persons or property by reason of the nature of the Work or from the elements, or by reason of inadequate protection of the Work, or from any carelessness or negligence on his part or on the part of his employees. The County will withhold payments on the Work until all suits or claims for damages sustained on, or by reason of, this Work will have been settled by the Contractor.

The construction and final completion of this Work will be guaranteed by the Contractor. Any damages that may be done to the Work or any part thereof, by the elements or otherwise, during its construction, will be made good by the Contractor.

44. LIQUIDATED DAMAGES

If the Project is not completed within the time specified herein or within such further time as may have been granted by the County Engineer, then the Contractor hereby agrees to pay to the County as liquidated damages, but not as a penalty, \$1,000.00 per day for each and every calendar day that he is in default on time to complete the Work. The said sum will be deducted from moneys due the Contractor and if the damages exceed this amount, then the Contractor or his Surety Company will pay the excess. These damages may be waived at the option of the County.

45. AFFIRMATIVE ACTION REQUIREMENTS

EXHIBIT B (Revised 4/10)

MANDATORY EQUAL EMPLOYMENT OPPORTUNITY LANGUAGE N.J.S.A. 10:5-31 et seq. (P.L. 1975, C. 127) N.J.A.C. 17:27

CONSTRUCTION CONTRACTS

During the performance of this contract, the contractor agrees as follows:

The contractor or subcontractor, where applicable, will not discriminate against any employee or applicant for employment because of age, race, creed, color, national origin, ancestry, marital status, affectional or sexual orientation, gender identity or expression, disability, nationality or sex. Except with respect to affectional or sexual orientation and gender identity or expression, the contractor will ensure that equal employment opportunity is afforded to such applicants in recruitment and employment, and that employees are treated during employment, without regard to their age, race, creed, color, national origin, ancestry, marital status, affectional or sexual orientation, gender identity or expression, disability, nationality or sex. Such equal employment opportunity shall include, but not be limited to the following: employment, up-grading, demotion, or transfer; recruitment or recruitment advertising; layoff or termination; rates of pay or other forms of compensation; and selection for training, including apprenticeship. The contractor agrees to post in conspicuous places, available to employees and applicants for employment, notices to be provided by the Public Agency Compliance Officer setting forth provisions of this nondiscrimination clause.

The contractor or subcontractor, where applicable will, in all solicitations or advertisements for employees placed by or on behalf of the contractor, state that all qualified applicants will receive consideration for employment without regard to age, race, creed, color, national origin, ancestry, marital status, affectional or sexual orientation, gender identity or expression, disability, nationality or sex.

The contractor or subcontractor will send to each labor union, with which it has a collective bargaining agreement, a notice, to be provided by the agency contracting officer, advising the labor union or workers' representative of the contractor's commitments under this act and shall post copies of the notice in conspicuous places available to employees and applicants for employment.

The contractor or subcontractor, where applicable, agrees to comply with any regulations promulgated by the Treasurer, pursuant to N.J.S.A. 10:5-31 et seq., as amended and supplemented from time to time and the Americans with Disabilities Act.

When hiring or scheduling workers in each construction trade, the contractor or subcontractor agrees to make good faith efforts to employ minority and women workers in each construction trade consistent with the targeted employment goal prescribed by N.J.A.C. 17:27-7.2; provided, however, that the Division may, in its discretion, exempt a contractor or subcontractor from

compliance with the good faith procedures prescribed by the following provisions, A, B and C, as long as the Division is satisfied that the contractor or subcontractor is employing workers provided by a union which provides evidence, in accordance with standards prescribed by the Division, that its percentage of active "card carrying" members who are minority and women workers is equal to or greater than the targeted employment goal established in accordance with N.J.A.C. 17:27-7.2. The contractor or subcontractor agrees that a good faith effort shall include compliance with the following procedures:

(A) If the contractor or subcontractor has a referral agreement or arrangement with a union for a construction trade, the contractor or subcontractor shall, within three business days of the contract award, seek assurances from the union that it will cooperate with the contractor or subcontractor as it fulfills its affirmative action obligations under this contract and in accordance with the rules promulgated by the Treasurer pursuant to N.J.S.A. 10:5-31 et. seq., as supplemented and amended from time to time and the Americans with Disabilities Act. If the contractor or subcontractor is unable to obtain said assurances from the construction trade union at least five business days prior to the commencement of construction work, the contractor or subcontractor agrees to afford equal employment opportunities minority and women workers directly, consistent with this chapter. If the contractor's or subcontractor's prior experience with a construction trade union, regardless of whether the union has provided said assurances, indicates a significant possibility that the trade union will not refer sufficient minority and women workers consistent with affording equal employment opportunities as specified in this chapter, the contractor or subcontractor agrees to be prepared to provide such opportunities to minority and women workers directly, consistent with this chapter, by complying with the hiring or scheduling procedures prescribed under (B) below; and the contractor or subcontractor further agrees to take said action immediately if it determines that the union is not referring minority and women workers consistent with the equal employment opportunity goals set forth in this chapter.

(B) If good faith efforts to meet targeted employment goals have not or cannot be met for each construction trade by adhering to the procedures of (A) above, or if the contractor does not have a referral agreement or arrangement with a union for a construction trade, the contractor or subcontractor agrees to take the following actions:

(1) To notify the public agency compliance officer, the Division, and minority and women referral organizations listed by the Division pursuant to N.J.A.C. 17:27-5.3, of its workforce needs, and request referral of minority and women workers;

(2) To notify any minority and women workers who have been listed with it as awaiting available vacancies;

(3) Prior to commencement of work, to request that the local construction trade union refer minority and women workers to fill job openings, provided the contractor or subcontractor has a referral agreement or arrangement with a union for the construction trade;

(4) To leave standing requests for additional referral to minority and women workers with the local construction trade union, provided the contractor or subcontractor has a referral agreement or arrangement with a union for the construction trade, the State Training and Employment Service and other approved referral sources in the area;

(5) If it is necessary to lay off some of the workers in a given trade on the construction site, layoffs

shall be conducted in compliance with the equal employment opportunity and non-discrimination standards set forth in this regulation, as well as with applicable Federal and State court decisions;

(6) To adhere to the following procedure when minority and women workers apply or are referred to the contractor or subcontractor:

(i) The contractor or subcontractor shall interview the referred minority or women worker.

(ii) If said individuals have never previously received any document or certification signifying a level of qualification lower than that required in order to perform the work of the construction trade, the contractor or subcontractor shall in good faith determine the qualifications of such individuals. The contractor or subcontractor shall hire or schedule those individuals who satisfy appropriate qualification standards in conformity with the equal employment opportunity and non-discrimination principles set forth in this chapter. However, a contractor or subcontractor shall determine that the individual at least possesses the requisite skills, and experience recognized by a union, apprentice program or a referral agency, provided the referral agency is acceptable to the Division. If necessary, the contractor or subcontractor shall hire or schedule minority and women workers who qualify as trainees pursuant to these rules. All of the requirements, however, are limited by the provisions of (C) below.

(iii) The name of any interested women or minority individual shall be maintained on a waiting list, and shall be considered for employment as described in (i) above, whenever vacancies occur. At the request of the Division, the contractor or subcontractor shall provide evidence of its good faith efforts to employ women and minorities from the list to fill vacancies.

(iv) If, for any reason, said contractor or subcontractor determines that a minority individual or a woman is not qualified or if the individual qualifies as an advanced trainee or apprentice, the contractor or subcontractor shall inform the individual in writing of the reasons for the determination, maintain a copy of the determination in its files, and send a copy to the public agency compliance officer and to the Division.

(7) To keep a complete and accurate record of all requests made for the referral of workers in any trade covered by the contract, on forms made available by the Division and submitted promptly to the Division upon request.

(C) The contractor or subcontractor agrees that nothing contained in (B) above shall preclude the contractor or subcontractor from complying with the union hiring hall or apprenticeship policies in any applicable collective bargaining agreement or union hiring hall arrangement, and, where required by custom or agreement, it shall send journeymen and trainees to the union for referral, or to the apprenticeship program for admission, pursuant to such agreement or arrangement. However, where the practices of a union or apprenticeship program will result in the exclusion of minorities and women or the failure to refer minorities and women consistent with the targeted county employment goal, the contractor or subcontractor shall consider for employment persons referred pursuant to (B) above without regard to such agreement or arrangement; provided further, however, that the contractor or subcontractor shall not be required to employ women and minority advanced trainees and trainees in numbers which result in the employment of advanced trainees and trainees as a percentage of the total workforce for the construction trade, which percentage significantly exceeds the apprentice to journey worker ratio specified in the applicable collective bargaining agreement, or in the absence of a

collective bargaining agreement, exceeds the ratio established by practice in the area for said construction trade. Also, the contractor or subcontractor agrees that, in implementing the procedures of (B) above, it shall, where applicable, employ minority and women workers residing within the geographical jurisdiction of the union.

After notification of award, but prior to signing a construction contract, the contractor shall submit to the public agency compliance officer and the Division an initial project workforce report (Form AA 201) electronically provided to the public agency by the Division, through its website, for distribution to and completion by the contractor, in accordance with N.J.A.C. 17:27-7. The contractor also agrees to submit a copy of the Monthly Project Workforce Report once a month thereafter for the duration of this contract to the Division and to the public agency compliance officer.

The contractor agrees to cooperate with the public agency in the payment of budgeted funds, as is necessary, for on-the-job and/or off-the-job programs for outreach and training of minorities and women.

(D) The contractor and its subcontractors shall furnish such reports or other documents to the Division of Public Contracts Equal Employment Opportunity Compliance as may be requested by the Division from time to time in order to carry out the purposes of these regulations, and public agencies shall furnish such information as may be requested by the Division of Public Contracts Equal Employment Opportunity Compliance for conducting a compliance investigation pursuant to **Subchapter 10 of the Administrative Code (NJAC 17:27)**.

[REMAINDER OF PAGE INTENTIONALLY LEFT BLANK]

46. INVESTMENT ACTIVITIES WITH IRAN

Pursuant to *N.J.S.A. 52:32-55 et seq.*, prohibits State and local public contracts with persons or entities engaging in certain investment activities in energy or finance sectors of Iran.

47. COMPLIANCE WITH THE PUBLIC WORKS CONTRACTOR REGISTRATION ACT - (N.J.S.A. 34:11-56.48 et seq.)

Pursuant to the above-referenced law, Bidders are required to be registered with the New Jersey Department of Labor and Workforce Development and to possess a current certificate by said Department indicating compliance with the Act prior to the time and date that bids are received. Bidders are notified of this requirement of their compliance. Such certificates or applications shall also be provided for each Subcontractor furnishing plumbing and gas fitting, steam and hot water heating and ventilating apparatus, and all kindred work, steam power plants and kindred work, electrical work, structural steel and ornamental iron work, and such other subcontractors as the specifications require relative to prior identification.

48. UTILITIES

Attention of the bidder is directed to the fact that the approximate locations of known utility structures and facilities that may be encountered within and adjacent to the limits of the Work are shown on the plans and described herein. The accuracy and completeness of this information is not guaranteed by the County Engineer and the bidder is advised to ascertain for himself all the facts concerning the location of these and other utilities.

The Contractor will not proceed with his Work until he has made diligent inquiries of all public utility and municipal officials to determine the exact location of all underground structures and pipes within the site of the Project. The Contractor will notify utility owners not less than ten (10) days in advance of the time he proposes to perform any Work that will endanger or affect their facilities in compliance with **New Jersey One-Call**. In excavating in any part of the Work, care must be taken not to remove or damage any gas, water, sewer, or other pipe, conduit, or structure, - public or private - without the concurrence of the owner and the County Engineer. The Contractor will, at his own expense, shore up, secure and maintain a continuous flow in such structures, and will keep them in repair until final acceptance of the Work.

When pipes or other structures are encountered or when the removal, relocation or protection of these utilities are necessary in carrying out the Project as planned, the Contractor will cooperate with the owner of said utilities and will permit the owners or their agents access to the site of the Work in order to relocate or protect their facilities and not hinder or delay unnecessarily the Work of the owners in moving same. No extra allowance of payment will be made to the Contractor for the use of any materials, equipment, etc.,

or for the performance of any Work in connection with the moving of said structures unless the Contractor is specifically ordered by the County Engineer to furnish such materials, equipment, or services. If directed by the County Engineer to do any Work or furnish any materials or equipment, payment will be allowed the Contractor in accordance with the unit prices bid for such Work, or, if such items are not scheduled in the proposal, such Work shall be allowed "Supplemental Work" as provided in Section 39 of these general specifications. The corporations, companies, agencies or municipalities owning or controlling the utilities, and the name, and telephone numbers are listed in the beginning of the Technical Specifications.

49. MATERIAL COMPLIANCE AND SHOP DRAWINGS

The Contractor will require the manufacturer or supplier to furnish three (3) copies of Certification of Compliance with each delivery of materials, components and manufactured items for the Project. Two (2) copies will be furnished to the County Engineer; one copy will be retained by the Contractor. Certificates of Compliance will contain the following information:

1. Project to which material is consigned;
2. Name of the Contractor to which the material is supplied;
3. Kind of material supplied;
4. Quantity of material represented by the Certificate;
5. Means of identifying the consignment, such as label marking, seal number, etc.;
6. Date and method of shipment;
7. That the material is in conformity with the pertinent specifications stated in the certificate; and
8. Signature of a person having legal authority to bind the supplier.

The Contractor will submit to the County Engineer for his approval five (5) copies of complete and fully detailed shop or working drawings for those items listed in the beginning of the technical specifications.

Each drawing will identify the name of the job, location and Contractor.

All drawings will be approved in accordance with the standard specifications. Refer to the Technical Specifications for specific items.

All materials or articles used in the Work will be of American manufacture, insofar as same are available, in conformance with N.J.S.A. 40A:11-18.

50. PRECONSTRUCTION

In order to provide full coordination of this Project among the parties concerned, the County Engineer will arrange for a preconstruction meeting between the Contractor, County Engineer and other interested parties as soon as possible after the contract is executed. At this meeting the Contractor will present his proposed schedule of Work which shall be subject to review and approval of the County through its designated representatives.

51. DISPUTES UNDER THE CONTRACT

A dispute arising under the Contract shall be submitted in writing to the County Engineer with all facts and supporting data. The County Engineer will review the dispute and issue his decision or request additional facts or documentation after which he will render his decision.

In the event the dispute is not then resolved, the matter shall, pursuant to law, be submitted to mediation before being submitted to a court of competent jurisdiction venued in Union County.

The County Engineer will notify the County Counsel when a matter is to be submitted to mediation. The County Counsel will communicate with the parties and inform them of the procedures to be followed in making such a submission.

[REMAINDER OF PAGE INTENTIONALLY LEFT BLANK]

**52. ORDINANCE NO. 557-2002 ADOPTED ON SEPTEMBER 5, 2002
BY THE BOARD OF CHOSEN FREEHOLDERS**

Ordinance No. 557-2002 adopted on September 5, 2002 by the Board of Chosen Freeholders on Preclassification of Bidders by the NJDPMC (**if applicable**) pursuant to Ordinance No. 557-2002, the County of Union requires all bidders on projects for the construction, reconstruction, demolition, alteration, repair or maintenance of public buildings to be preclassified by the State of New Jersey, Department of Treasury, Division of Property Management and Construction ("DPMC").

Bidders must provide proof of classification in the form of a Certificate/Notice of Classification from the DPMC showing a sufficient aggregate rating to cover their bid amount, which is active on the date of receipt of these bids. Further, Bidder must also provide proof of preclassification in the applicable/appropriate trade code necessary for Work on the Project.

AN ORDINANCE IN ACCORDANCE WITH N.J.S.A. 40A:11-25 ESTABLISHING REASONABLE REGULATIONS APPROPRIATE FOR CONTROLLING THE QUALIFICATIONS OF PROSPECTIVE BIDDERS UPON CONTRACTS TO BE AWARDED ON BEHALF OF THE CONTRACTING UNIT, BY THE CLASS OR CATEGORY OF GOODS AND SERVICES TO BE PROVIDED OR PERFORMED AND FIXING THE QUALIFICATIONS REQUIRED ACCORDING TO THE FINANCIAL ABILITY AND EXPERIENCE OF THE BIDDERS AND THE CAPITAL AND EQUIPMENT AVAILABLE TO THEM PERTINENT TO AND REASONABLY RELATED TO THE CLASS AND CATEGORY OF SERVICE TO BE PERFORMED IN THE PERFORMANCE OF ANY SUCH CONTRACT.

WHEREAS, N.J.S.A. 40A:11-25 provides that the governing body of any contracting unit may establish reasonable regulations appropriate for controlling the qualifications of prospective bidders upon contracts to be awarded on behalf of the contracting unit, by the class or category of goods and services to be provided or performed; and

WHEREAS, N.J.S.A. 40A:11-25 also states that the regulations established by the governing body may fix the qualifications required according to the financial ability and experience of the bidders and the capital and equipment available to them pertinent to and reasonably related to the class and category of service to be performed in the performance of any such contract; and

WHEREAS, N.J.S.A. 40A:11-25 also requires that prior to the adoption of any such regulations, a contracting unit shall submit them to a public hearing and notice and a general description of the subject matter shall be published in not less than two newspapers; and

WHEREAS, N.J.S.A. 52:35-1 et seq. and 18A:18A-27 et seq. establish qualifications for the experience and financial abilities of bidders and the capital and equipment available to them relative to the specific services to be performed; and

WHEREAS, currently state officials, under the Department of Treasury, Division of Property Management and Construction, classify all prospective bidders as to the character and amount of public works on which they shall be qualified to submit bids and bids shall be accepted only from persons qualified in accordance with such classifications; and

WHEREAS, application for classification is open to all Contractors, regardless of the size of the business; and

WHEREAS, classification is based on general standards equally applicable to all Contractors; and

WHEREAS, classification is expressed in terms of trade and an aggregate rating determined on the basis of experience, financial ability, equipment and capital; and

WHEREAS, generally aggregate ratings can range from 0 to \$200,000.00; and

WHEREAS, the County of Union will determine the aggregate rating it will require on contracts depending on the size and expense of the Project, but at no time shall the required aggregate rating exceed \$25,000,000.00 for any one project; and

WHEREAS, such provisions are of considerable benefit to the County and to bidders by insuring that such bidders have the requisite experience, expertise and resources necessary to effectively perform the terms and conditions of the contract:

BE IT ORDAINED by the Board of Chosen Freeholders of the County of Union that it formally adopts as **Policy** that all prospective bidders for building construction projects be classified in accordance with the Department of Treasury – Division of Property Management and Construction pursuant to N.J.S.A. 52:35-1 *et seq.* and N.J.S.A. 18A:18A-27 *et seq.*

BE IT FURTHER ORDAINED that the Board of Chosen Freeholders of the County of Union hereby adopts the classification of bidders by the New Jersey Department of Treasury, Division of Property Management and Construction as a reasonable regulation for controlling the qualifications of prospective bidders upon contracts to be awarded for construction on behalf of the County of Union.

BE IT FURTHER ORDAINED that the provisions of this ordinance are severable. To the extent any clause, phrase, sentence, paragraph or provision of this ordinance shall be declared invalid, illegal or unconstitutional, the remaining provisions shall continue to be in full force and effect.

BE IT FURTHER ORDAINED that a public hearing shall be held on this ordinance on September 5, 2002 at the meeting of the Board of Freeholders, County Administration Building, Elizabeth, New Jersey.

BE IT FURTHER ORDAINED that the Clerk of the Board of Freeholders of the County is hereby directed to publish and post notice of this ordinance as required by law.

BE IT FURTHER ORDAINED that within 10 days hereof the Clerk of the Board of Freeholders of the County shall forward certified copies of this ordinance to the County Manager, Director of Finance, County Counsel, and Division of Local Government Services.

This ordinance shall take effect twenty (20) days after final adoption and publication in accordance with applicable law.

53. CONTRACTOR BUSINESS REGISTRATION CERTIFICATE

G-30

Revised: 2020.03.03

Pursuant to N.J.S.A. 52:32-44, the County of Union is prohibited from entering into a contract with an entity unless the bidder/proposer/contractor, and each subcontractor that is required by law to be named in a bid/proposal/contract has a valid Business Registration Certificate on file with the Division of Revenue and Enterprise Services within the Department of the Treasury.

Prior to contract award or authorization, the contractor shall provide the County of Union with its proof of business registration and that of any named subcontractor(s).

Subcontractors named in a bid or other proposal shall provide proof of business registration to the bidder, who in turn, shall provide it to the County of Union prior to the time a contract, purchase order, or other contracting document is awarded or authorized.

During the course of contract performance:

- 1) the contractor shall not enter into a contract with a subcontractor unless the subcontractor first provides the contractor with a valid proof of business registration.
- 2) the contractor shall maintain and submit to the County of Union a list of subcontractors and their addresses that may be updated from time to time.
- 3) the contractor and any subcontractor providing goods or performing services under the contract, and each of their affiliates, shall collect and remit to the Director of the Division of Taxation in the Department of the Treasury, the use tax due pursuant to the Sales and Use Tax Act, (N.J.S.A. 54:32B-1 et seq.) on all sales of tangible personal property delivered into the State. Any questions in this regard can be directed to the Division of Taxation at (609)292-6400. Form NJ-REG can be filed online at <http://www.state.nj.us/treasury/revenue/busregcert.shtml>.

Before final payment is made under the contract, the contractor shall submit to the County of Union a complete and accurate list of all subcontractors used and their addresses.

Pursuant to N.J.S.A. 54:49-4.1, a business organization that fails to provide a copy of a business registration as required, or that provides false business registration information, shall be liable for a penalty of \$25 for each day of violation, not to exceed \$50,000, for each proof of business registration not properly provided under a contract with a contracting agency.

54. BID PROTEST – LEGAL FEES AND COSTS

G-31

Revised: 2020.03.03

In the event a Bidder unsuccessfully challenges a Bid Submission by filing an action in a court of law concerning same, said Bidder shall be responsible for payment of reasonable legal costs and fees incurred by the County relating to said protest.

55. AMERICAN GOODS AND PRODUCTS WHERE POSSIBLE

Bidder shall comply with the requirements of NJSA 40A:11-18 and use only manufactured and farm products of the United States, wherever available, for the Project.

56. NEW JERSEY PAY-TO-PLAY REQUIREMENTS

This Contract is required by law to be publicly advertised for bids. As such, lists of political contributions pursuant to N.J.S.A. 19:44A-1 et seq. are NOT REQUIRED to be provided with the bids.

57. STATEMENT OF EQUIPMENT TO BE USED IN CONSTRUCTION

Pursuant to N.J.S.A. 40A:11-20 entitled Certificate of Bidder Showing Ability to Perform Contract, the County requires a Certification from all bidders submitting a bid showing that the Bidder owns, leases, or controls all necessary equipment required by the Project Plans and Specifications. All bidders shall provide this information at the time of the bid opening using the attached form entitled, "CERTIFICATE OF BIDDER SHOWING ABILITY TO PERFORM CONTRACT".

If the Bidder is not the actual owner of the equipment, it shall state the source from which the equipment will be obtained and shall attach a certificate from the owner or person in control of the equipment demonstrating that the equipment owner has granted the Bidder control of the requisite equipment during such time as may be necessary for completion of the portion of the contract for which the equipment is necessary.

58. NEW JERSEY SALES AND USE TAX REQUIREMENTS,

Contractors are required to comply with the following:

New Jersey Sales and Use Tax Requirements: All contractors with subcontractors, or any of their affiliates, who enter into contracts for the provision of goods or services with or for New Jersey local government entities, are required to collect and remit to the New Jersey Director of Taxation in the Department of the Treasury the use tax due on all of their sales of tangible personal property delivered into the State of New Jersey pursuant to the "Sales and Use Tax Act," (N.J.S.A. 54:32B-1 et seq.), regardless of whether the tangible personal property is intended for a contract with the contracting agency. This tax shall be remitted for the term of the Contract.

For purposes herein “affiliate” shall mean any entity that: (a) directly, indirectly, or constructively controls another entity, (b) is directly, indirectly, or constructively controlled by another entity, or (c) is subject to the control of a common entity. For purposes of the immediately preceding sentence, an entity controls another entity if it owns, directly or indirectly, more than fifty percent (50%) of the ownership interest in that entity. NJSA 52:32-44(g)(3).

BIDDER'S NAME: _____

EDWARD T. OATMAN
COUNTY MANAGER

MICHELLE HAGOPIAN, ASSISTANT DIRECTOR
DIVISION OF PURCHASING

BID DOCUMENT SUBMISSION CHECKLIST

**ALL SIGNATURES AND SEALS SHALL BE ORIGINALS UNLESS OTHERWISE SPECIFIED
BID SHEETS SHOULD NOT BE SUBMITTED DOUBLE SIDED PAGES, (SINGLE SIDE ONLY)**

EACH BIDDER SHOULD COMPLETE THIS FORM AND INITIAL EACH ENTRY.

DATE COMPLETED: _____

**PLEASE SUBMIT BID DOCUMENTS ON SINGLE SIDED PAPER ONLY, WITH THE EXCEPTION OF
THE SURETY AND BID BOND DOCUMENTS.**

**IN ACCORDANCE WITH THE BID SPECIFICATIONS I HAVE REVIEWED, COMPLETED / EXECUTED
AND INCLUDED THE FOLLOWING FORMS:**

_____ Bid Form Page (**Signed, Dated and Bid on all alternatives applicable to the Work**).

_____ Security in the form of:

_____ Bid bond in an amount equal to 10% of the total amount of this bid not to exceed \$20,000.00; or

_____ Certified check or cashier's check in the amount of 10% of this bid not to exceed \$20,000.00

_____ Consent of Surety form signed by a Surety Company if the total amount of your Bid is over \$36,000.00. If your bid is accepted, the Surety Company that provided the Consent shall be required to furnish a Performance, Labor and Materials Bond in the amount of 100% of the award of the contract.

The County of Union has provided its Consent of Surety form for your use. The use of this form by your Surety Company will expedite the bid review process and eliminate the possibility of having your bid rejected. If, however, you should need to use another form, please use language similar to that used on the Union County form and avoid making any additions or deletions to the Union County form language. In lieu of the Consent of Surety you may submit a Certified Check in the full amount of the bid.

_____ STATEMENT OF BIDDER OWNERSHIP. Pursuant to N.J.S.A. 52:25-24.2, which includes **BOTH** of the following documents:

- Bidder Signature Page
- Bidder Disclosure Statement (**Fill out 2 pages completely**)

_____ SUBCONTRACTOR IDENTIFICATION. Pursuant to N.J.S.A. 40A:11-16, which includes **BOTH** of the following documents:

- Subcontractor Identification Statement: List of Subcontractors (**only for certain types of work**)
- Subcontractor Identification Certification

_____ Acknowledgement of Addendum form: (**This form is to be used only when an addendum has been added to the specifications**).

_____ A copy of the State of New Jersey Department of the Treasury, Division of Revenue, **Business Registration Certificate ("BRC")** may be included with the bids to expedite the contract process because the bidder is required to provide the County of Union with its proof of business registration and that of any named subcontractor(s) prior to contract award or authorization,

BIDDER'S NAME: _____

_____ A copy of the State of New Jersey Department of the Treasury, Division of Revenue, **Business Registration Certificate ("BRC")** of all named or listed subcontractors (List of Subcontractors) in a Construction bid may be included with the bid as the BRC(s) for each named or listed subcontractors in order to expedite the contract process. Subcontractors named in a bid or other proposal shall provide proof of business registration to the bidder, who in turn, shall provide it to the County of Union prior to the time a contract, purchase order, or other contracting document is awarded or authorized.

_____ Affirmative Action Requirement

_____ Experience Statement

_____ Certificate of Bidder showing ability to perform Contract

_____ Non-Collusion Affidavit – Fill out completely and notarize

_____ Certificates from New Jersey Department of Labor and Workforce and Workforce Development – Public Works Contractor Registration Act. **(Only for certain types of work)**

_____ Federal Attachments **(If applicable)**

_____ NJDPMC Certificate / Notice of Classification **(If applicable)**

_____ Americans with Disabilities Act

_____ Statement of Bidder's Qualifications

_____ Contractor Performance Record

_____ Affidavit Regarding List of Debarred, Suspended or Disqualified Bidders

_____ Prior Negative Experience Questionnaire

_____ Contractor's Certification of Compliance – New Jersey Prevailing Wage Act

_____ Uncompleted Contracts Affidavit **(For Bidder, if applicable) MUST ALSO PROVIDE DPMC FORM 701**

_____ Certificate of Insurance Statement

_____ Collection of Use Tax on Sales to Local Government Statement

_____ Time of Completion

_____ Disclosure of Investment Activities in Iran Certification Form

I HAVE TAKEN THE FOLLOWING ACTIONS:

_____ Visited the site and attended the Pre-Bid Meeting **(Where applicable)**

_____ Reviewed the Contract Documents (including any permits the County or its professionals may have obtained), Work, Site, Locality, and Local Conditions and Laws and Regulations that in any manner may affect Cost, Progress, Performance or Furnishing of Work.

_____ Reviewed Bond Requirements

_____ Provided Proof of Compliance with New Jersey Prevailing Wage Act

_____ Reviewed Form of Owner/Contractor Agreement and General Conditions to the Contract

NOTE: QUESTIONS PERTAINING TO THIS BID ARE TO BE DIRECTED TO DIVISION OF ENGINEERING AT 908-789-3675

BIDDER'S NAME: _____

BIDDING DOCUMENTS

The Bidding Documents consist of the following items:

- **ADDENDA, if issued**
- **CLARIFICATIONS, if issued**
- **INSTRUCTION TO BIDDERS**
- **BID FORM**
- **OWNER-CONTRACTOR AGREEMENT (AIA 101) AND GENERAL CONDITIONS (AIA 201)**
- **SPECIFICATIONS:** As outlined in the Table of Contents and included in the Project Manual.
- **DRAWINGS:** As per List of Drawings, indicated on the Project Title Sheet.

BIDDER'S NAME: _____

BID FORM

I/We have carefully examined the plans, specifications, and advertisement for bid for the

**INTERSECTION IMPROVEMENTS AT SOUTH MICHIGAN AVENUE & QUINTON AVENUE,
BOROUGH OF KENILWORTH, COUNTY OF UNION, NEW JERSEY
BA#20-2020; UNION COUNTY ENGINEERING PROJECT #2018-012**

that is on file in the Union County Division of Engineering. I/We have inspected the site of the work and will contract to do all the work and furnish all materials mentioned in said plans and specifications. Work will be accomplished in the manner prescribed therein.

BASE BID ITEMS:

ITEM	CONTRACT QUANTITY	UNITS	DESCRIPTION	UNIT PRICE	AMOUNT
1	1	LS	CONSTRUCTION LAYOUT	\$	\$
2	1	LS	SOIL EROSION AND SEDIMENT CONTROL	\$	\$
3	-	-	NO ITEM	\$0.00	\$0.00
4	50	UN	DRUM	\$	\$
5	50	UN	TRAFFIC CONE	\$	\$
6	150	SF	CONSTRUCTION SIGNS	\$	\$
7	ALLOWANCE	ALLOWANCE	POLICE TRAFFIC DIRECTOR	\$10,000.00	\$ 10,000.00
8	1	LS	CLEARING SITE	\$	\$
9	1	UN	TRAFFIC CONTROL TRUCK WITH MOUNTED CRASH CUSION	\$	\$
10	16	HR	TRAFFIC DIRECTOR, FLAGGER	\$	\$
11	1	UN	FLASHING ARROW BOARD 2' X 4'	\$	\$
12	-	-	NO ITEM	\$0.00	\$0.00

BIDDER'S NAME: _____

ITEM	CONTRACT QUANTITY	UNITS	DESCRIPTION	UNIT PRICE	AMOUNT
13	-	-	NO ITEM	\$0.00	\$0.00
14	-	-	NO ITEM	\$0.00	\$ 0.00
15	-	-	NO ITEM	\$0.00	\$0.00
16	35	LF	TRAFFIC MARKINGS, LINES, THERMOPLASTIC, 24"	\$	\$
17	55	SF	REGULATORY AND WARNING SIGN	\$	\$
18	80	LF	REMOVAL OF TRAFFIC STRIPES	\$	\$
19	4	UN	TRAFFIC SIGNAL HEAD	\$	\$
20	2	UN	ADVANCED PUSH BUTTON	\$	\$
21	150	LF	TRAFFIC SIGNAL CABLE, 2 CONDUCTORS	\$	\$
22	150	LF	TRAFFIC SIGNAL CABLE, 5 CONDUCTORS	\$	\$
23	450	LF	TRAFFIC SIGNAL CABLE, 10 CONDUCTORS	\$	\$
24	1	UN	ADVANCED PEDESTRIAN CONTROLLER	\$	\$
25	105	LF	3" RIGID METALLIC CONDUIT, TYPE CUG	\$	\$
26	1	UN	CONTROLLER, 2 PHASES	\$	\$
27	1	UN	FOUNDATION, TYPE P-MC	\$	\$
28	1	UN	FOUNDATION, TYPE STF	\$	\$

BIDDER'S NAME: _____

ITEM	CONTRACT QUANTITY	UNITS	DESCRIPTION	UNIT PRICE	AMOUNT
29	1	UN	FOUNDATION, TYPE SPF	\$	\$
30	2	UN	18" X 36" JUNCTION BOX	\$	\$
31	30	LF	SERVICE WIRE, NO. 6 AWG	\$	\$
32	150	LF	GROUND WIRE, NO. 8 AWG	\$	\$
33	1	UN	TRAFFIC SIGNAL STANDARD, STEEL, BLACK	\$	\$
34	1	UN	TRAFFIC SIGNAL MAST ARM, STEEL, BLACK	\$	\$
35	1	UN	PEDESTRIAN SIGNAL STANDARD, BLACK	\$	\$
36	2	UN	PEDESTRIAN SIGNAL HEAD	\$	\$
37	1	UN	UPS SYSTEM, COMPLETE	\$	\$
38	1	UN	METER CABINET, TYPE T	\$	\$
39	1	UN	CONTROLLER TURN-ON	\$	\$
40	25	SY	CONCRETE SIDEWALK, 4" THICK	\$	\$
41	2	SY	DETECTABLE WARNING SURFACE	\$	\$
42	25	SY	TOPSOIL SPREADING, 4" THICK	\$	\$
43	25	SY	FERTILIZING AND SEEDING, TYPE A-3	\$	\$
44	25	SY	FIBER MULCH	\$	\$

BIDDER'S NAME: _____

TOTAL BASE BID ITEMS:

Written

Figures

BID CONTINGENCY: (To be used if and when directed by the County)

Twenty Thousand Dollars and No Cents
Written

\$20,000
Figures

TOTAL BASE BID ITEMS PLUS BID CONTINGENCY AMOUNT:

Written

Figures

NOTE: Bid Contingency may include one-half of one percent of contract amount set aside for local training if and when directed by the County.

BIDDER'S NAME: _____

ALTERNATES:

Alternates may be added to the Total Base Bid Amount. The bid will be awarded and / or Alternate will be selected as follows:

No Alternates for this Bid.

CONSENT OF SURETY

TO ACCOMPANY PROPOSAL (BID)

_____ (hereinafter called Surety), organized and existing under the laws of the State of _____ duly authorized and qualified to transact business in the State of New Jersey, in consideration of the sum of One Dollar (\$1.00), lawful money of the United States of America, to it in hand paid, receipt whereof is hereby acknowledged, and in consideration, hereby certifies and agrees that if the contract for which the attached proposal is made be awarded to _____ (hereinafter called Contractor) for the performance of certain work and labor or the supplying of certain materials, or both, as more particularly set forth in said proposal and described for purposes of this instrument as a proposal for _____ to the COUNTY OF UNION and if Contractor shall enter into the contract, Surety will become bound as surety for its faithful performance, labor and material payment and

BIDDER'S NAME: _____

will provide the Contractor with a performance, labor and material payment bond in the full amount of the contract price.

NOTE:
Expiration date
Needed if Annual
Surety

NAME OF INSURANCE COMPANY

ADDRESS: _____

ORIGINAL SIGNATURE
ATTORNEY-IN-FACT FOR INSURANCE CO.

NOTE: PROOF OF AUTHORITY OF OFFICERS OF SURETY COMPANY TO EXECUTE THIS DOCUMENT MUST BE SUBMITTED.

BIDDER'S NAME: _____

BIDDER SIGNATURE PAGE

THE BIDDER MUST READ THE FOLLOWING INSTRUCTIONS TO COMPLETE THIS PAGE:

1. If doing business under a **trade name, partnership or a sole proprietorship**, you must submit the bid under exact title of the trade name, partnership, or proprietorship, and the bid must be signed by either the **owner**, or a **partner** and **witnessed** by a **notary public**.
2. If a **Corporation**, the bid must be signed by the **President** or **Vice President** and **witnessed** by a **Corporate Secretary** (corporate title must be exact) and **affix corporate seal**. If a Corporate Secretary does not exist, President or Vice President's signature shall be witnessed by a Notary Public.
3. Other persons **authorized** by **corporate resolution** to execute agreements in its behalf may also sign the bid documents (pages). **Copy of a resolution must accompany the bid**.
4. The person who signs this bid form **must also** sign the **Non-Collusion Affidavit**.
5. You **cannot** witness your own signature.

NAME OF BIDDER

ADDRESS OF BIDDER

ORIGINAL SIGNATURE
CORPORATE SECRETARY

PRINT NAME AND TITLE
CORPORATE SECRETARY

TEL: _____
FAX: _____
E-Mail: _____

BY: _____
ORIGINAL SIGNATURE

Corporate Seal

PRINT OR TYPE NAME AND TITLE

WARNING: IF YOU FAIL TO FULLY, ACCURATELY, AND COMPLETELY SUPPLY THE INFORMATION REQUESTED ON THIS PAGE, YOUR BID MAY BE REJECTED.

BIDDER'S NAME: _____

STATEMENT OF OWNERSHIP DISCLOSURE

N.J.S.A. 52:25-24.2 (P.L. 1977, c.33, as amended by P.L. 2016, c.43)

This statement shall be completed, certified to, and included with all bid and proposal submissions. Failure to submit the required information is cause for automatic rejection of the bid or proposal.

Name of Organization: _____

Organization Address: _____

Part I Check the box that represents the type of business organization:

- Sole Proprietorship (skip Parts II and III, execute certification in Part IV)
- Non-Profit Corporation (skip Parts II and III, execute certification in Part IV)
- For-Profit Corporation (any type) Limited Liability Company (LLC)
- Partnership Limited Partnership Limited Liability Partnership (LLP)
- Other (be specific): _____

Part II

- The list below contains the names and addresses of all stockholders in the corporation who own 10 percent or more of its stock, of any class, or of all individual partners in the partnership who own a 10 percent or greater interest therein, or of all members in the limited liability company who own a 10 percent or greater interest therein, as the case may be. **(COMPLETE THE LIST BELOW IN THIS SECTION)**

OR

- No one stockholder in the corporation owns 10 percent or more of its stock, of any class, or no individual partner in the partnership owns a 10 percent or greater interest therein, or no member in the limited liability company owns a 10 percent or greater interest therein, as the case may be. **(SKIP TO PART IV)**

(Please attach additional sheets if more space is needed):

BIDDER'S NAME: _____

Name of Individual or Business Entity	Home Address (for Individuals) or Business Address

Part III DISCLOSURE OF 10% OR GREATER OWNERSHIP IN THE STOCKHOLDERS, PARTNERS OR LLC MEMBERS LISTED IN PART II

If a bidder has a direct or indirect parent entity which is publicly traded, and any person holds a 10 percent or greater beneficial interest in the publicly traded parent entity as of the last annual federal Security and Exchange Commission (SEC) or foreign equivalent filing, ownership disclosure can be met by providing links to the website(s) containing the last annual filing(s) with the federal Securities and Exchange Commission (or foreign equivalent) that contain the name and address of each person holding a 10% or greater beneficial interest in the publicly traded parent entity, along with the relevant page numbers of the filing(s) that contain the information on each such person. **Attach additional sheets if more space is needed.**

Website (URL) containing the last annual SEC (or foreign equivalent) filing	Page #'s

Please list the names and addresses of each stockholder, partner or member owning a 10 percent or greater interest in any corresponding corporation, partnership and/or limited liability company (LLC) listed in Part II **other than for any publicly traded parent entities referenced above.** The disclosure shall be continued until names and addresses of every noncorporate stockholder, and individual partner, and member exceeding the 10 percent ownership criteria established pursuant to N.J.S.A. 52:25-24.2 has been listed. **Attach additional sheets if more space is needed.**

BIDDER'S NAME: _____

Stockholder/Partner/Member and Corresponding Entity Listed in Part II	Home Address (for Individuals) or Business Address

Part IV Certification

I, being duly sworn upon my oath, hereby represent that the foregoing information and any attachments thereto to the best of my knowledge are true and complete. I acknowledge: that I am authorized to execute this certification on behalf of the bidder/proposer; that the **County of Union** is relying on the information contained herein and that I am under a continuing obligation from the date of this certification through the completion of any contracts with **County of Union** to notify the **County of Union** in writing of any changes to the information contained herein; that I am aware that it is a criminal offense to make a false statement or misrepresentation in this certification, and if I do so, I am subject to criminal prosecution under the law and that it will constitute a material breach of my agreement(s) with the, permitting the **County of Union** to declare any contract(s) resulting from this certification void and unenforceable.

Full Name (Print):		Title:	
Signature:		Date:	

BIDDER'S NAME: _____

SUBCONTRACTOR IDENTIFICATION STATEMENT

LIST OF SUBCONTRACTORS

This form is ONLY required for plumbing and gas fitting, steam and hot water heating and ventilating apparatus, steam power plants, electrical work, structural steel, ornamental iron work, and any other trades required to be identified by the specifications (including, but not limited, to satisfying any DPMC Classification requirements).

CHECK THIS BOX IF NONE OF THE ABOVE LISTED TRADES OR THOSE REQUIRED TO BE IDENTIFIED IN THE SPECIFICATIONS ARE TO BE USED TO PERFORM THE WORK

In compliance with N.J.S.A. 40A:11-16 and the bid specifications, the undersigned hereby lists the name or names of the following subcontractors:

Company Name: _____

Address: _____

Telephone: _____ Subcontract Amount: \$ _____

Specific Scope of Work Subcontracted: _____

License No. _____

Company Name: _____

Address: _____

Telephone: _____ Subcontract Amount: \$ _____

Specific Scope of Work Subcontracted: _____

License No. _____

Company Name: _____

Address: _____

Telephone: _____ Subcontract Amount: \$ _____

Specific Scope of Work Subcontracted: _____

License No. _____

IF MORE THAN THREE SUBCONTRACTORS, PLEASE COPY THIS SHEET AS NECESSARY AND ATTACH TO THE BID PACKAGE.

(Continued on following page)

BIDDER'S NAME: _____

SUBCONTRACTOR IDENTIFICATION CERTIFICATION

Note the law does not permit the listing of alternate subcontractors. However, multiple subcontractors for the same trade are permitted to be named provided the bidder meets the following requirements:

- Bidder identifies each subcontractor named for that category;
- Bidder states the scope of work, goods and services (the portion of the work) to be performed by each subcontractor; and
- Bidder provides the price quote provided by each subcontractor.

The bidder is advised that any change of subcontractor(s) from ones listed herein is subject to the County's approval. Change of subcontractor(s) will be approved only if made for good cause and not as a result of an arbitrary purpose.

The undersigned Bidder certifies and declares that the subcontractors listed above shall be used as subcontractors to complete certain portions of the work in this project as set forth in N.J.S.A. 40A: 11-16.

Witness

Date _____

NAME OF BIDDER

ADDRESS

By: _____
ORIGINAL SIGNATURE ONLY

PRINT NAME AND TITLE

BIDDER'S NAME: _____

ACKNOWLEDGMENT OF ADDENDUM

COUNTY OF UNION

(Name of Construction /Public Works Project)

(Project or Bid Number)

Pursuant to N.J.S.A. 40A:11-23.1a., the undersigned bidder, hereby acknowledges receipt of the following notices, revisions, or addenda to the bid advertisement, specifications or bid documents. By indicating date of receipt, bidder acknowledges the submitted bid takes into account the provisions of the notice, revision or addendum. Note that the County of Union's record of notice to bidders shall take precedence and that failure to include provisions of changes in a bid proposal may be subject for rejection of the bid.

Local Unit Reference Number or Title of Addendum/Revision	How Received (mail, fax, pick-up, etc.)	Date Received

ACKNOWLEDGMENT BY BIDDER:

NAME OF BIDDER: _____

ORIGINAL SIGNATURE: _____

PRINTED NAME AND TITLE: _____

DATE: _____

BIDDER'S NAME: _____

BUSINESS REGISTRATION

Pursuant to N.J.S.A. 52:32-44, the County of Union is prohibited from entering into a contract with an entity unless the bidder/proposer/contractor, and each subcontractor that is required by law to be named in a bid/proposal/contract has a valid Business Registration Certificate on file with the Division of Revenue and Enterprise Services within the Department of the Treasury.

Prior to contract award or authorization, the contractor shall provide the County of Union with its proof of business registration and that of any named subcontractor(s).

Subcontractors named in a bid or other proposal shall provide proof of business registration to the bidder, who in turn, shall provide it to the County of Union prior to the time a contract, purchase order, or other contracting document is awarded or authorized.

During the course of contract performance:

- (1) the contractor shall not enter into a contract with a subcontractor unless the subcontractor first provides the contractor with a valid proof of business registration.
- (2) the contractor shall maintain and submit to the County of Union a list of subcontractors and their addresses that may be updated from time to time.
- (3) the contractor and any subcontractor providing goods or performing services under the contract, and each of their affiliates, shall collect and remit to the Director of the Division of Taxation in the Department of the Treasury, the use tax due pursuant to the Sales and Use Tax Act, (N.J.S.A. 54:32B-1 et seq.) on all sales of tangible personal property delivered into the State. Any questions in this regard can be directed to the Division of Taxation at (609)292-6400. Form NJ-REG can be filed online at <http://www.state.nj.us/treasury/revenue/busregcert.shtml>.

Before final payment is made under the contract, the contractor shall submit to the County of Union a complete and accurate list of all subcontractors used and their addresses.

Pursuant to N.J.S.A. 54:49-4.1, a business organization that fails to provide a copy of a business registration as required, or that provides false business registration information, shall be liable for a penalty of \$25 for each day of violation, not to exceed \$50,000, for each proof of business registration not properly provided under a contract with a contracting agency.

BIDDER'S NAME: _____

STATE OF NEW JERSEY
BUSINESS REGISTRATION CERTIFICATE
FOR STATE AGENCY AND CASINO SERVICE CONTRACTORS

DEPARTMENT OF TREASURY
DIVISION OF REVENUE
PO BOX 382
TRENTON, NJ 08646

TAXPAYER NAME: TAX REGISTRATION TEST ACCOUNT
TRADE NAME: CLIENT REGISTRATION
TAXPAYER IDENTIFICATION #: 970-097-382/000
SEQUENCE NUMBER: 0107230
ADDRESS: 847 ROEBLING AVE
TRENTON NJ 08611
ISSUANCE DATE: 07/14/04
EFFECTIVE DATE: 01/01/01

FORM BRC(06-01)

John S. Easley
Authorized

This Certificate is NOT assignable or transferable. It must be temporarily displayed at above address.

STATE OF NEW JERSEY
BUSINESS REGISTRATION CERTIFICATE

Taxpayer Name: TAX REG TEST ACCOUNT
Trade Name:
Address: 847 ROEBLING AVE
TRENTON, NJ 08611
Certificate Number: 1093907
Date of Issuance: October 14, 2004

For Office Use Only:
20041014112813533

ATTACH BRC HERE

BIDDER'S NAME: _____

AFFIRMATIVE ACTION REQUIREMENT

REQUIRED AFFIRMATIVE ACTION EVIDENCE

General Requirements of P.L. 1975, c. 127: You are hereby put on notice that:

CONSTRUCTION CONTRACTS: The successful contractor must submit within three (3) days of the notice of intent to award or the signing of the contract the initial project manning report (A.A.201). This report should be submitted at the time the signed contract is returned to the County of Union. Attention: *Affirmative Action Officer*.

If the successful contract does not submit the initial project manning report (A.A.201) within the three (3) days from the time the signed contract is returned to the County of Union, the County of Union WILL declare the contractor non-responsive and award the contract to the next lowest responsible bidder.

NAME OF BIDDER

ORIGINAL SIGNATURE

PRINT OR TYPE NAME AND TITLE

DATE THIS FORM IS COMPLETED

BIDDER'S NAME: _____

EXPERIENCE STATEMENT

I hereby certify that my company has performed the following private or public work, which is relevant to this bid. I further certify that my company has never defaulted under any contract. Should you not sign this form due to prior defaults, please provide details on an attached sheet.

Witness

Date

NAME OF BIDDER

ADDRESS

By: _____
ORIGINAL SIGNATURE ONLY

PRINT NAME AND TITLE

YOU MAY ATTACH ADDITIONAL SHEETS, BUT YOU MUST SIGN AND WITNESS THIS SHEET.

BIDDER'S NAME: _____

CERTIFICATE OF BIDDER SHOWING ABILITY TO PERFORM CONTRACT

STATE OF NEW JERSEY / _____)
 Specify, if Other) SS:
COUNTY OF _____)

I, _____, of the (City, Town, Borough, etc.) of _____
_____ State of _____, of full age, being duly sworn according
to law on my oath depose and say that:

I am _____ of the firm of _____,
the Bidder making the proposal for the above named Project ("Contractor"), and that I executed said
proposal with full authority to do so; and that said Contractor, pursuant to N.J.S.A. 40A:11-20, certifies
that it owns, leases or controls all the necessary equipment required by the Plans, Specifications and
Advertisements under this Bids are asked for.

If the Bidder is not the actual owner or lessee of any such equipment, then the Bidder shall attach to this
Certificate information identifying the source from which the equipment will be obtained, and such
information shall be accompanied by a certificate from the owner or person in control of the equipment
definitively granting to the Bidder the control of the equipment required during such time as may be
necessary for the completion of that portion of the contract.

(Also type or print name of affiant under signature)

By: _____

BIDDER'S NAME: _____

Contractor Registration Advisement
For Public Works Projects

A new law, known as "The Public Works Contractor Registration Act" (P.L. 1999, c.238), became effective April 11, 2000. Under the Act, no contractor/subcontractor will be permitted to bid on or engage in any contract for public work, as defined in Section 2 of P.L. 1963, c.150 (C:34:11-56.26), unless that contractor/subcontractor is registered with the New Jersey Department of Labor and Workforce and Workforce Development. The Act provides that upon registration with the Department, a public works contractor/subcontractor will be issued a certificate by the Department indicating compliance with the Act's requirements. The registration fee has been set at \$300.00 per year. Upon the effective date of the Act, public bodies will be expected to request production of such a certificate from those bidding on or engaging in public works projects.

It is important to note that the term "contractor," is defined in the Act as, "a person, partnership, association, joint stock company, trust, corporation or other legal business entity or successor thereof who enters into a contract which is subject to the provision of the "New Jersey Prevailing Wage Act," P.L. 1963, c.150 (C.34:11-56.25, et seq.) for the construction, reconstruction, demolition, alteration, repair or maintenance of a public building regularly open to and used by the general public or a public institution, and includes any subcontractor or lower tier subcontractor as defined herein: except that, for the purposes of the act, no pumping station, treatment plant or other facility associated with utility and environmental construction, reconstruction, demolition, alteration, repair or maintenance shall be regarded as a public building regularly open to and used by the general public or a public institution."

Registration forms, copies of the Act, and other relevant information can be obtained by contacting:

Contractor Registration Unit
New Jersey Department of Labor and Workforce and Workforce Development
Division of Wage & Hour Compliance
PO Box 389
Trenton, New Jersey 08625-0389
Telephone: 609-292-9464
Fax: 609-633-8591
E-mail: contreg@dol.state.nj.us

BIDDER'S NAME: _____

AMERICANS WITH DISABILITIES ACT
EQUAL OPPORTUNITY FOR INDIVIDUALS WITH DISABILITIES

The contractor and the County of Union (hereafter "Owner") do hereby agree that the provisions of Title II of the Americans With Disabilities Act of 1990 (the "Act") (42 U.S.C. S12101 et seq.), which prohibits discrimination on the basis of disability by public entities in all services, programs and activities provided or made available by public entities, and the rules and regulations promulgated pursuant thereto, are made a part of this contract. In providing any aid, benefit, or service on behalf of the Owner pursuant to this contract, the contractor agrees that the performance shall be in strict compliance with the Act. In the event the contractor, its agents, servants, employees, or subcontractors violate or are alleged to have violated the Act during the performance of this contract, the contractor shall defend the Owner in any action or administrative proceeding commenced pursuant to this Act. The contractor shall indemnify, protect, and save harmless the Owner, its agents, servants, and employees from and against any and all suits, claims, losses, demands, or damages of whatever kind or nature arising out of or claimed to arise out of the alleged violation. The contractor shall, at its own expense, appear, defend, and pay any and all charges for legal services and any and all costs and other expenses arising from such action or administrative proceeding or incurred in connection therewith. In any and all complaints brought pursuant to the Owner's grievance procedure, the contractor agrees to abide by any decision of the Owner which is rendered pursuant to said grievance procedure. If any action or administrative proceeding results in an award of damages against the Owner, or if the Owner incurs any expense to cure a violation of the ADA which has been brought pursuant to its grievance procedure, the contractor shall satisfy and discharge the same at its own expense.

The Owner shall, as soon as practicable after a claim has been made against it, give written notice thereof to the contractor along with full and complete particulars of the claim. If any action or administrative proceeding is brought against the Owner or any of its agents, servants, and employees, the Owner shall expeditiously forward or have forwarded to the contractor every demand, complaint, notice, summons, pleading, or process received by the Owner or its representatives.

It is expressly agreed and understood that any approval by the Owner of the services provided by the contractor pursuant to this contract will not relieve the contractor of the obligation to comply with the Act and to defend, indemnify, protect, and save harmless the Owner pursuant to this paragraph.

It is further agreed and understood that the Owner assumes no obligation to indemnify or save harmless the contractor, its agents, servants, employees and subcontractors for any claim which may arise out of their performance of this Agreement. Furthermore, the contractor expressly understands and agrees that the provisions of this indemnification clause shall in no way limit the contractor's obligations assumed in this Agreement, nor shall they be construed to relieve the contractor from any liability, nor preclude the Owner from taking any other actions available to it under any other provisions of this Agreement or otherwise at law.

Name _____
(Please print or type)

Signature _____ **Date** _____

BIDDER'S NAME: _____

STATEMENT OF BIDDER'S QUALIFICATIONS

All questions must be answered and the data given must be clear and comprehensive. This statement must be notarized. Questions may be answered on separate attached sheets. The Bidder may submit any additional information it desires.

1. _____
(Name of Bidder)

2. _____
(Permanent Main Office Address)

3. _____
(When Organized)

4. _____
(If a Corporation, where incorporated)

5. Number of years your organization has been engaged in construction or contracting business under present firm or trade name? _____

6. How many years of experience in construction work has your organization had (a) as a general contractor? And/or (b) As a subcontractor? _____

7. Contracts on hand: (Attach a list or table showing gross amounts of each Contract and the appropriate dates of completion) _____

8. General character of work performed by you. _____

9. Have you ever failed to complete any work awarded to you? _____

10. Have you ever defaulted on a Contract? _____ If so, complete details, including where and why?

BIDDER'S NAME: _____

STATEMENT OF BIDDER'S QUALIFICATIONS - (continued)

11. Has any officer or partner of your organization ever failed to complete a construction contract handled in its own name? If so, state name of individual, name of owner, location and type of project, and reason for the failure to complete. _____

12. List your major equipment available for this Contract.

13. Experience in the construction work similar in importance to this Project.

14. Have you had any material adverse changes from the trades as listed in NJ Notice of Classification within last five (5) years? _____. If so, list prior classification.

15. Background and experience of the principal members of your organization, including the officers.

Individual's Name	Present Position or Office	Yrs. of Construction Experience	Magnitude & Type of Work	In What Capacity

BIDDER'S NAME: _____

16. Bank Reference. (Name, Address, Phone, Representative) _____

17. Will you, upon request, fill out a detailed financial Statement? _____

18. The undersigned hereby authorizes and requests any person, firm or corporation to furnish any information requested by the proper agency in verification of the responses comprising this Statement of Bidder's Qualifications.

19. Bidder's telephone number, fax number and e-mail address (if applicable).

Phone _____

Fax _____

E-mail _____

Mobile _____

Dated at _____ this _____ day of _____, 20____.

BIDDER (Signature)

BIDDER (Print Name)

Subscribed and sworn to before me
this _____ day of _____, 20____.

(Seal) Notary Public of New Jersey/
Specify Other State
My Commission Expires _____, 20____.

**NOTE: FAILURE TO COMPLETE AND SUBMIT THIS DOCUMENT WITH YOUR PROPOSAL
MAY RESULT IN A REJECTION OF YOUR BID.**

BIDDER'S NAME: _____

CONTRACTOR PERFORMANCE RECORD

List all contracts completed by you below or provide separate form.

Name of Owner	Name & Location of Project: Type Of Work	Prime or Sub-Cont.	Engineer or Architect in Charge for Owner	Contract Price (Omit Cost)	Date Completed	Was Time* Extension Necessary	Were Any Penalties Imposed	Were Liens* Claims or Stop Notice Filed

* If answer is YES, provide explanation of details in connection with non-completion of contracts, time extensions, penalties imposed, labor troubles, liens, claims and notices filed against contracts listed in preceding item "Performance Record" on an attached sheet.

NOTE: FAILURE TO COMPLETE AND SUBMIT THIS DOCUMENT WITH YOUR PROPOSAL MAY RESULT IN A REJECTION OF YOUR BID.

BIDDER'S NAME: _____

CERTIFICATION

The information above is true and complete to the best of my knowledge and belief.

(Name of Organization)

(Signature)

(Title)

Subscribed and sworn to before me
This _____ day of _____, 20____.

(Seal) Notary Public of New Jersey/
Specify Other State
My Commission Expires _____, 20____.

BIDDER'S NAME: _____

PRIOR NEGATIVE EXPERIENCE QUESTIONNAIRE

(N.J.S.A. 40A:11-4)

1. Within the past ten (10) years, have you been found, through either court adjudication, arbitration, mediation, or other contractually stipulated alternate dispute resolution mechanism, to have: failed to provide or perform goods or services; or failed to complete a contract in a timely manner; or otherwise performed unsatisfactorily under a prior contract with a public entity?

_____ yes _____ no If yes, please provide full, detailed explanation.

2. Within the past ten (10) years, have you defaulted on a contract, thereby requiring a public entity to utilize the services of another contractor to provide the goods or perform the services or to correct or complete the contract?

_____ yes _____ no If yes, please provide full, detailed explanation.

3. Within the past ten (10) years, have you defaulted on a contract, thereby requiring a public entity to look to your surety for completion of the contract or tender of the costs of completion?

_____ yes _____ no If yes, please provide full, detailed explanation.

4. Within the past ten (10) years, have you been debarred or suspended from contracting with any of the agencies or department of the executive branch of the State of New Jersey at the time of the contract award, where the action was based on failure to perform a contract for goods or services with a public entity?

_____ yes _____ no If yes, please provide full, detailed explanation.

BIDDER'S NAME: _____

PRIOR NEGATIVE EXPERIENCE CERTIFICATION

I hereby certify that the above statements are true and accurate as of this _____
day of _____, 20__.

Name of Contractor

By _____
(Signature of Authorized Representative)

Subscribed and sworn to before me
This _____ day of _____, 20__.

(Seal) Notary Public of New Jersey/
Specify Other State
My Commission Expires _____, 20__.

**NOTE: FAILURE TO COMPLETE AND SUBMIT THIS DOCUMENT WITH YOUR
PROPOSAL MAY RESULT IN A REJECTION OF YOUR BID.**

BIDDER'S NAME: _____

TO BE COMPLETED ONLY WHEN FINAL PAYMENT IS REQUESTED

CONTRACTOR'S CERTIFICATION OF COMPLIANCE - NEW JERSEY PREVAILING WAGE ACT

TO: County of Union
Division of Engineering
2325 South Avenue
Scotch Plains, New Jersey 07076

CONTRACT:

PROJECT:

In accordance with the requirements of the New Jersey Prevailing Wage Act, N.J.S.A. 34:11-56 et al *, the undersigned contractor on the public work being performed for:

COUNTY OF UNION

hereby certifies that he/she has complied with the contract requirements regarding the payment of the minimum prevailing wages established under "The New Jersey Prevailing Wage Act" N.J.S.A. 34:11-56 et al.

CONTRACTOR: _____
ADDRESS: _____

BY: _____

ORIGINAL SIGNATURE ONLY

STATE OF NEW JERSEY
COUNTY OF _____

Being by me duly sworn according to law, on his oath deposes and says that _____ is _____ of _____ the above named contractor, and that the facts set forth in the above statement are true.

Subscribed and sworn before me
this ____ day of _____, 20____.

Notary Public: _____
My Commission Expires: _____

* N.J.S.A. 34:11-56.33 requires the contractor and subcontractor to file written statements with the public body in form satisfactory to the Commissioner certifying to the amounts then due and owing from such contractor and subcontractor filing such statement to any and all workmen for wages due on account of the public work, setting forth therein the names of the persons whose wages are unpaid and the amount due to each respectively. Union County will withhold the amount so deducted for the benefit of the workmen whose wages are unpaid as shown by the verified statement filed, and will pay directly to any workman the amount shown by such statement to be due to him for such wages. Such payment shall thereby discharge the obligation of the contractor to the person receiving such payment to the extent of the amount thereof.

BIDDER'S NAME: _____

UNCOMPLETED CONTRACTS AFFIDAVIT
(To be submitted with DPMC Form 701)

PURSUANT TO N.J.A.C. 17:19-2.13, BIDDER DECLARES THE FOLLOWING WITH RESPECT TO ITS UNCOMPLETED CONTRACTS, ON ALL WORK, FROM WHATEVER SOURCE (PUBLIC AND PRIVATE), BOTH IN NEW JERSEY AND FROM OTHER GOVERNMENTAL JURISDICTIONS

ENTITY	PROJECT TITLE	ORIGINAL CONTRACT AMOUNT	UNCOMPLETED AMOUNT AS OF BID OPENING DATE	NAME AND TELEPHONE NUMBER OF PARTY TO BE CONTACTED FROM ENTITY FOR VERIFICATION

TOTAL AMOUNT OF UNCOMPLETED CONTRACTS \$ _____

Sworn and Subscribed to Before me

This _____ day of _____ 20____

Notary Public

BIDDER:

(Signature)

(Print Name)

NOTE: FAILURE TO COMPLETE AND SUBMIT THIS DOCUMENT WITH YOUR PROPOSAL MAY RESULT IN A REJECTION OF YOUR BID.

BIDDER'S NAME: _____

CERTIFICATE OF INSURANCE STATEMENT

The Bidder fully understands the County of Union insurance requirements as stated in the Instructions to Bidders as well as the Owner/Contractor Agreement and agrees to provide all insurance required by these documents prior to the issuance of the Notice to Proceed.

BIDDER (Signature)

BIDDER (Print Name)

NOTE: FAILURE TO COMPLETE AND SUBMIT THIS DOCUMENT WITH YOUR PROPOSAL MAY RESULT IN A REJECTION OF YOUR BID.

BIDDER'S NAME: _____

COLLECTION OF USE TAX ON SALES TO LOCAL GOVERNMENTS STATEMENT

The Bidder fully understands the requirements of the use tax on sales to local governments as stated in the General Conditions to the Contract for Construction and the Instructions to Bidders, and agrees at all times to comply with the "Contractor Use Tax Collection Legislation", as defined therein, and the terms relating thereto contained in the Contract Documents.

BIDDER (Signature)

BIDDER (Print Name)

NOTE: FAILURE TO COMPLETE AND SUBMIT THIS DOCUMENT WITH YOUR PROPOSAL MAY RESULT IN A REJECTION OF YOUR BID.

BIDDER'S NAME: _____

TIME OF COMPLETION

The undersigned proposed that if awarded the Contract, the scope of work will be started within ten (10) calendar days and will be substantially completed within **90 calendar days** from the date of the notice to proceed.

I, _____ of _____
NAME (Print or type) COMPANY

Agree to complete work in the time frame specified _____
SIGNATURE

SITE VISIT – GENERAL CONTRACTOR

I, _____ of _____
NAME (Print or type) COMPANY

Visited the site of the work on _____
SIGNATURE

BIDDER'S NAME: _____

**COUNTY OF UNION NEW JERSEY
Division of Purchasing
DISCLOSURE OF INVESTMENT ACTIVITIES IN IRAN FORM**

Solicitation Number: _____

Vendor/Bidder: _____

PART 1

CERTIFICATION

VENDOR/BIDDER MUST COMPLETE PART 1 BY CHECKING ONE OF THE BOXES
FAILURE TO CHECK ONE OF THE BOXES WILL RENDER THE PROPOSAL NON-RESPONSIVE

Pursuant to Public Law 2012, c. 25, any person or entity that submits a bid or proposal or otherwise proposes to enter into or renew a contract must complete the certification below to attest, under penalty of perjury, that neither the person nor entity, nor any of its parents, subsidiaries, or affiliates, is identified on the State of New Jersey, Department of the Treasury's Chapter 25 list as a person or entity engaged in investment activities in Iran. The Chapter 25 list is found on the Department's website at <http://www.state.nj.us/treasury/pdf/Chapter25List.pdf>. Vendors/Bidders **must** review this list prior to completing the below certification. **Failure to complete the certification will render a Vendor's/Bidder's proposal non-responsive.** If the Director of the Division of Purchase and Property finds a person or entity to be in violation of the law, s/he shall take action as may be appropriate and provided by law, rule or contract, including but not limited to, imposing sanctions, seeking compliance, recovering damages, declaring the party in default and seeking debarment or suspension of the party.

CHECK THE APPROPRIATE BOX

A. I certify, pursuant to Public Law 2012, c.25, that neither the Vendor/Bidder listed above nor any of its parents, subsidiaries, or affiliates is listed on the N.J. Department of Treasury's list of entities determined to be engaged in prohibited activities in Iran pursuant to P.L. 2012, c. 25 ("Chapter 25 List"). Disregard Part 2 and complete and sign the Certification below.

OR

B. I am unable to certify as above because the Vendor/Bidder and/or one or more of its parents, subsidiaries, or affiliates is listed on the Department's Chapter 25 list. I will provide a detailed, accurate and precise description of the activities in Part 2 below and sign and complete the Certification below. Failure to provide such information will result in the proposal being rendered as non-responsive and appropriate penalties, fines and/or sanctions will be assessed as provided by law.

PART 2

PLEASE PROVIDE ADDITIONAL INFORMATION RELATED TO INVESTMENT ACTIVITIES IN IRAN

If you checked Box "B" above, provide a detailed, accurate and precise description of the activities of the Vendor/Bidder, or one of its parents, subsidiaries or affiliates, engaged in investment activities in Iran by completing the information below.

ENTITY NAME: _____
RELATIONSHIP TO VENDOR/BIDDER: _____
DESCRIPTION OF ACTIVITIES: _____
DURATION OF ENGAGEMENT: _____
ANTICIPATED CESSATION DATE: _____
VENDOR/BIDDER CONTACT NAME: _____
VENDOR/BIDDER CONTACT PHONE#: _____

Attach Additional Sheets If Necessary

CERTIFICATION

I, the undersigned, certify that I am authorized to execute this certification on behalf of the Vendor/Bidder, that the foregoing information and any attachments hereto, to the best of my knowledge are true and complete. I acknowledge that the County of Union, New Jersey is relying on the information contained herein, and that the Vendor/Bidder is under a continuing obligation from the date of this certification through the completion of any contract(s) with the County of Union to notify the County of Union in writing of any changes to the information contained herein; that I am aware that it is a criminal offense to make a false statement or misrepresentation in this certification. If I do so, I will be subject to criminal prosecution under the law, and it will constitute a material breach of my agreement(s) with the County of Union, permitting the County of Union to declare any contract(s) resulting from this certification void and unenforceable.

Signature

Date

Print Name and Title

Revised 10/19/17

STANDARD SPECIFICATIONS

The Standard Specifications for Road and Bridge Construction of New Jersey Department of Transportation, 2007 Edition; is added to and/or amended elsewhere herein by the Notice to Contractors (Advertisement), Proposal, Information for Bidders, General Conditions, Supplemental Conditions, Project Plans, and Supplementary Specifications; shall, insofar as technical requirements are involved, govern in the execution of this project.

Such Standard Specifications are made a part of these Specifications by this reference and will not be repeated herein. It is the responsibility of prospective bidders to familiarize themselves with these Standard Specifications, copies of which may be examined at the office of the Engineer and may be obtained, upon payment of the cost thereof, from:

Department of Transportation
State of New Jersey
1035 Parkway Avenue
Trenton, New Jersey 08625

The Notice to Contractors (Advertisement), Proposal, General Conditions, Special Provisions, Project Plans and/or Supplementary Specifications shall govern and prevail in the case of conflict between them and the Standard Specifications.

In these Standard Specifications the words "COMMISSIONER" or "DEPARTMENT" shall refer to and mean the person, persons, body, board or agent legally empowered to enter into contracts and otherwise legally act for the Owner. The word "STATE" shall refer to and mean the professional engineering representative of the Owner as hereinbefore defined and the word "ENGINEER" shall refer to and mean the professional engineering representative of the Owner as hereinbefore defined and the word "INSPECTOR" shall mean the authorized project representative of the Engineer with the authority as hereinbefore defined. The word "LABORATORY" shall mean and refer to the Engineer who may, at his discretion, and with the consent of the Owner, employ qualified technical personnel or testing laboratories to assist him in fulfilling the duties normally assigned to the "LABORATORY" in these Standard Specifications.

When reference is made herein to the bulletins, standards, specifications, publications or requirements of the American Association of State Highway Official (AASHO), the American Concrete Institute (ACI), the American Society of Civil Engineers (ASCE) or similar national or regional societies, associations, institutes or organizations; the requirements of the bulletins, specifications, publications or requirements referred to shall be considered a part of these Specifications by such reference and shall not be repeated herein but shall have the same import and be as binding as if herein set forth in full.

TECHNICAL SPECIFICATIONS

CONDITIONS SPECIFIC TO THIS PROJECT

Intersection Improvements at South Michigan Avenue & Quinton Avenue, in the Borough of Kenilworth. The work shall include the installation of a HAWK traffic signal, installation of traffic signing, and removal and replacement of traffic striping.

There are underground utilities within the project area, as well as overhead utilities on the west side of Caldwell Place. This utility pole is not in conflict with proposed construction and therefore no action to relocate the utility is required.

The contractor shall coordinate their work with any planned utility relocations as part of the construction and the existing utilities that will remain in their present location. It is the sole responsibility of the Contractor to investigate and use due care when operating in the vicinity of any utility. No additional compensation will be made for utility coordination and any other work involving the existing utilities.

Prior to the start of work, the Contractor shall go over the limits of all work with the Engineer or duly appointed representative.

The time of completion for this project has been set at Ninety (90) calendar days from the Notice to Proceed.

It is noted punch-list items will invariably arise. To minimize disruption to its citizens, the County shall require all punch-list items brought to the Contractor's attention to be rectified within seven (7) calendar days from receipt of said items. If said punch-list items are not resolved to the satisfaction of the Engineer within the specified time, Liquidated Damages as specified in Section 43 of the General Specifications ('G' sheets of this specification) shall be pursued, commencing on the eighth calendar day.

The County retains the right to increase or decrease any and all quantities up to twenty-five percent (25%) of those estimated, at the unit prices bid.

Certified payroll records shall be produced and submitted on a bi-weekly basis to the County for all personnel involved with this project. The County shall withhold any and all payments until the certified payroll records are received.

SPECIAL PROVISIONS

AUTHORIZATION OF CONTRACT

The Contract is authorized by the provisions of Title 27 of the Revised Statutes of New Jersey and supplements thereto.

SPECIFICATIONS TO BE USED

The bound version of the 2007 Standard Specifications for Road and Bridge Construction, of the New Jersey Department of Transportation as amended herein will govern the construction of this Project and the execution of the Contract.

General wage determinations issued under Davis-Bacon and related acts, published by US Department of Labor, may be obtained from the Davis-Bacon web site at <http://www.access.gpo.gov/davisbacon/nj.html> under the appropriate county; select the construction type.

Pay the prevailing wage rates determined by the United States Secretary of Labor and the New Jersey Department of Labor. If the prevailing wage rate prescribed for any craft by the United States Secretary of Labor is not the same as the prevailing wage rate prescribed for that craft by the New Jersey Department of Labor, pay the higher rate.

State wage rates may be obtained from the New Jersey Department of Labor & Workforce Development (Telephone: 609-292-2259) or by accessing the Department of Labor & Workforce Development's web site at http://lwd.dol.state.nj.us/labor/wagehour/wagehour_index.html The State wage rates in effect at the time of award are part of this Contract, pursuant to Chapter 150, Laws of 1963 (NJSA 34:11-56.25, et seq.).

If an employee of the Contractor or subcontractor has been paid a rate of wages less than the prevailing wage, the Department may suspend the Work, and declare the Contractor in default.

State wage rates may be obtained from the New Jersey Department of Labor & Workforce Development (Telephone: 609-292-2259) or by accessing the Department of Labor & Workforce Development's web site at http://lwd.dol.state.nj.us/labor/wagehour/wagehour_index.html The State wage rates in effect at the time of award are part of this Contract, pursuant to Chapter 150, Laws of 1963 (N.J.S.A. 34:11-56.25 et seq.).

If an employee of the Contractor or subcontractor has been paid a rate of wages less than the prevailing wage, the Department may suspend the Work, and declare the Contractor in default.

The following Wholly State-funded project Attachments that are located at the end of these Special Provisions:"

1. State of New Jersey [Equal Employment Opportunity Special Provisions for Construction Contracts](#) Funded by Wholly or partially State Funds.
2. [Payroll Requirements](#) for 100 Percent State Projects.
3. [Americans with Disabilities Act](#) for 100 Percent State Funded Contracts.
4. Small Business Enterprise Utilization Attachment for 100% State Funded Contracts.

The following additional project specific Attachments are located at the end of these Special Provisions:

GENERAL

Award of contract and subletting will not be permitted to, materials will not be permitted from, and use of equipment will not be permitted that is owned and/or operated by, firms and individuals included in the report of suspensions, debarments and disqualifications of firms and individuals as maintained by the Department of the Treasury, General Services Administration, CN-039, Trenton NJ 08625 (609-633-3990).

Payment for a pay item in the proposal includes all the compensation that will be made for the work of that item as described in the contract documents unless the "basis of payment" clause provides that certain work essential to that item will be paid for under another pay item.

Whenever any section, subsection, subpart or subheading is amended by such terms as changed to, deleted or added it is construed to mean that it amends that section, subsection, subpart or subheading of the bound version of the 2007 Standard Specifications unless otherwise noted.

Whenever reference to page number is made, it is construed to refer to the bound version of the 2007 Standard Specifications, as amended herein, unless otherwise noted.

Henceforth in this supplementary specification whenever reference to the State, Commissioner, Department, Engineer or Inspector is made, it is construed to mean the UNION COUNTY ENGINEER.

Whenever reference to Title 27 is made, it is construed to mean Title 40.

Materials or assemblies as specified will be accepted on the basis of certificates of compliance stating that such materials or assemblies fully comply with the requirements of the contract.

Materials or assemblies used on the basis of certificates of compliance may be sampled and tested at any time and if found not to be in conformity with the contract requirements, will be subject to rejection whether in place or not. The Contractor shall require the manufacturer or supplier to furnish three copies of certificates of compliance with each delivery of materials, components and manufactured items that are acceptable by certification. One copy shall be furnished to the Engineer, one copy shall be furnished to the District Office, Bureau of Local Government Services and the Contractor shall retain one copy.

Certificates of compliance shall contain the following information:

1. Project and location to which the material is consigned.
2. Name of the Contractor to which the material is supplied.
3. Kind of material supplied.
4. Quantity of material represented by the certificate.
5. Means of identifying the consignment, such as label marking, seal number, etc.
6. Date and method of shipment.
7. Statement that the material has been tested and found in conformity with the pertinent contract requirements stated in the certificate.
8. Signature of a person having legal authority to bind the supplier.
9. Signature attested to by a Notary Public or other properly authorized person.

Payments relative to materials specified, shall be accepted on the basis of certificates of compliance shall not be made until the Engineer has in his possession an acceptable certificate of compliance.

FOREIGN MATERIALS

The attention of the Contractor is directed to all existing federal and state statutes and regulations that prohibit on any public work the use, by the Contractor or subcontractor, of materials produced or manufactured outside the United States of America. Exceptions to this prohibition, upon the findings of the Engineer, are allowed only where its enforcement would be inconsistent with the public interest or where the material is not produced or manufactured in the United States in sufficient quantities and of a sufficient quality.

If the Engineer finds in the performance of the contract there has been a failure to comply with the provisions relative to foreign materials, he shall make public his findings, and no other contract for the construction of any public work by this contracting agent shall be awarded to such Contractor, or to any partnership, association or corporation with which such Contractor is associated or affiliated, within a period of three years after such finding is made public.

Where the use of foreign material is allowed, such material shall be furnished in accordance with the following requirements:

1. Materials manufactured or produced outside the United States shall be delivered to a location, approved by the Engineer, where they shall be retained until examination can be completed.
2. The Contractor shall arrange, at his expense, any testing which the Engineer feel necessary to ascertain the acceptability of the material.
3. A certificate of compliance shall accompany each lot of foreign material. In addition, certified mill tests reports shall be attached to the certificate of compliance for those materials for which mill test reports are required and shall clearly identify the lot to which they apply. Certificates of compliance shall contain the following information:
 - A. Project to which the material is consigned.
 - B. Name of the Contractor to which the material is supplied.
 - C. Kind of material supplied.
 - D. Quantity of material represented by the certificate.
 - E. Means of identifying the consignment, such as label marking, seal number, etc.
 - F. Date and method of shipment.
 - G. Statement that the material has been tested and found in conformity with the pertinent contract requirements stated in the certificate.
 - H. Signature of a person having legal authority to bind the supplier.
 - I. Signature attested to by a notary public or other properly authorized person.

The following Sections of the Standard Specifications are deleted:

SECTION 102 - BIDDING REQUIREMENTS AND CONDITIONS
SECTION 103 - AWARD AND EXECUTION OF CONTRACT

The above Sections of the Standard Specifications are changed to the requirements of the County of Union in General Specifications attached hereto.

The below Sections of the Standard Specifications have been changed to the requirements of the County of Union as stipulated herein, in the event of conflicts between the below sections and those of Union County, Union County stipulations shall govern.

SECTION 104 - SCOPE OF WORK
SECTION 109 - MEASUREMENT AND PAYMENT

DIVISION 100 - GENERAL PROVISIONS

SECTION 101 - GENERAL INFORMATION

101.03 TERMS

THE FOLLOWING TERMS ARE CHANGED.

Completion

(3) IS CHANGED TO:

3. the Contractor has satisfactorily executed and delivered to the RE all documents, required forms, certifications, and proofs of compliance required by the Contract Documents, it being understood that the satisfactory execution and delivery of documents, certificates, and proofs of compliance is a requirement of the Contract.

Department: Shall be defined as the County of Union.

Resident Engineer (RE) shall be defined as a representative of the County of Union or Engineer.

Pavement Structure. The combination of pavement, base courses, and when specified, a subbase course, placed on a subgrade to support the traffic load and distribute it to the roadbed (see Figure 101-1). These various courses are defined as follows:

1. **Pavement.** One or more layers of specified material of designed thickness at the top of the pavement structure.
2. **Base course.** One or more layers of specified material of designed thickness placed on the subgrade or subbase.
3. **Subbase.** One or more layers of specified material of designed thickness placed on the subgrade.

SECTION 104 - SCOPE OF WORK

104.03.03 Types of Changes

3. Changes in the Character of Work.

a. Differing Site Condition.

THE SECOND PARAGRAPH IS CHANGED TO:

The Department will make payment for increased costs resulting from a Type 1 or Type 2 Differing Site Condition as a change in the character of work; however, the Department will not consider making payment for a differing site condition unless the resulting change in cost exceeds \$7,500. Except, if the Contractor incurs cost as the result of multiple differing site conditions, with the cost of each separate differing site condition having a value of at least \$1,500 but not more than \$7,500, the Department will consider making payment for such costs if the aggregate cost of the multiple differing site conditions exceeds \$7,500. If the change in cost exceeds these amounts, the Department will base the modification on the total cost of the change, and the Department will not deduct the threshold amount of \$7,500 from the cost of the change.

104.03.04 Contractual Notice

THE SECOND PARAGRAPH IS CHANGED TO:

Immediately provide written notice to the RE of a circumstance that is believed to be a change to the Contract, include the following in the initial written notice:

1. A statement that this is a notice of a change.
2. The date when the circumstances believed to be a change was discovered.
3. A detailed and specific statement describing the nature and circumstances of the change.
4. If the change will or could affect costs to the Department.
5. If the change will or could affect Contract Time as specified in 108.11.01.C.

In addition to the hard copy of the notice, email the notice to the RE. It is not necessary to attach listed documents to the email.

104.03.08 Force Account

7. Equipment.

a. Contractor-Owned Equipment.

PART 1 IS CHANGED TO:

- 1 The Department will calculate the “rental” hourly rates by dividing the monthly rate by 176. The Department will not use weekly, daily, or hourly rates. The Department will apply rental hourly rates for every hour the equipment is in active use, except that for any 30-day period, the Department will limit the total amount paid for each piece of equipment to a maximum of the monthly rate.

THE FOLLOWING PART IS ADDED:

6. The Department will make payment for costs for transporting equipment to and from the work site, if said costs are solely required as a direct result of the Force Account activity.

THE SECOND PARAGRAPH IS CHANGED TO:

The payment established is full payment for all equipment costs, including the cost of fuel, repairs, maintenance, depreciation, storage and incidentals.

10. Subcontractors.

THE SECOND PARAGRAPH IS CHANGED TO:

The Department will make payment for markup on subcontracted work at the rate of five percent (5%) applied on the total amount of all costs for subcontracted force account work up to \$500,000 and two percent (2%) applied on the total amount of all costs for subcontracted force account work over \$500,000.

104.03.09 Delay Damages

1. Non-Productive Activity.

e. Equipment.

THE FIRST SENTENCE IS CHANGED TO:

If as the result of the delay, equipment cannot be used for any active work, and is directed by the RE to remain on the work site during the delay, the Department will make payment as specified in 104.03.08.7.a.5.

SECTION 105 - CONTROL OF WORK

105.05 WORKING DRAWINGS

THE SECOND PARAGRAPH IS CHANGED TO:

Ensure that working drawing submissions also conform to the Department design manuals and other Department standards for the proposed work. After Award, the Department will provide additional formatting information, the number of copies required, and the address of the receiving designated design unit.

THE THIRD PARAGRAPH IS CHANGED TO:

Submit working drawings on 22 × 36-inch sheets. The Department may approve the use of 8-1/2 x 11-inch sheet on a case-by-case basis. Submit design calculations required for the working drawings on 8-1/2 × 11-inch paper. Submit seven (7) copies of the working drawings to the designated design unit for review with a copy of the transmittal letter to the RE. For railroad-carrying structures, submit four (4) additional copies to the designated design unit. Submit an additional copy for each outside testing agency or authority involved in the Project.

THE NINTH PARAGRAPH IS CHANGED TO:

Submit working drawings for certification or approval as specified in [Table 105.05-1](#). This list is not all-inclusive. Ensure that the working drawings submitted for approval are signed and sealed by a Professional Engineer. The working drawings submitted for certification are not required to be signed and sealed by a Professional Engineer unless they alter the original Contract.

TABLE 105.05-1 IS CHANGED TO:

Table 105.05 1 - Working Drawing Submission Category	
Certified	Approved
Breakaway I-Beam GA Sign Support Posts	Catalog Cuts (related to landscape Items)
Bridge Drainage	Change in Structural Steel Details
Bridge Railing and Fencing Anchorage System	Change of Pre-stressed Concrete Strand Patterns
Catalog Cuts	Demolition Plans
Composite Piles	Erection Plans
DMS Sign Support Structure	High Load Multi-Rotational (HLMR) Bearings
DMS Standard Ground Mounted	Isolation Bearings
Elastomeric Bearings Pads	ITS System Drawings, including Block Diagrams
Electrical Items Not Pre-Qualified	Machinery and Electrical Items for Movable Bridges
Expansion Deck Joint Assembly Systems	Mechanically Stabilized Earth (MSE) Walls
Modular Expansion Joint Assembly	Other work shown on the Plans as conceptual
Pre-cast Pre-stressed Concrete Beams and Piles Fabrication	Pre-cast Concrete Arch Structures
Reinforced Elastomeric Bearings	Pre-cast Concrete Box Culverts

Sign Legends	Prefabricated Modular Walls
Sign Support Structures	Stay-In-Place Forms
Structural Steel Fabrication	Temporary Sheeting and Cofferdams
	Temporary Shielding
	Temporary Structures
	Value Engineering Plans

THE FIRST PARAGRAPH UNDER PART 1 OF TENTH PARAGRAPH IS CHANGED TO:

- 1. Certified Working Drawings.** For working drawings requiring certification, include 2 blank blocks directly above the title block. Designate one block for design unit certification, and designate the other block for the Contractor’s approval stamp and a signed statement stating that the Contract has not been altered. The Department will require 30 days for review and certification or rejection and return of certified working drawings.

- 1. Certified Working Drawings.**

THE LAST SENTENCE OF THE FIRST PARAGRAPH IS CHANGED TO:

The Department will require 15 days for review and certification or rejection and return of certified working drawings.

- 2. Approved Working Drawings.**

THE LAST SENTENCE OF THE FIRST PARAGRAPH IS CHANGED TO:

The Department will require 15 days for review and approval or rejection and return of working drawings.

105.07 Cooperation with Utilities.

THE FOLLOWING HAS BEEN ADDED

- A. General.** It is understood and agreed the Contractor has considered in its Proposal all of the permanent and temporary utility facilities in their present, new, or relocated positions to the extent required by the Contract Documents and as revealed by its own investigations; is aware utility service demands, adverse field conditions and emergencies may affect the Utility’s ability to comply with the proposed schedules for utility work; is cognizant of the limited ability of the County to control the actions of the Utility(s), and has made allowances in its Proposal that it is not entitled to any Additional Compensation by reasons of delays, inconvenience or damage sustained by the Contractor due to any interference from utility facilities or the operation of moving or installing them. Similarly, the Contractor is deemed to understand only limited extensions of time may be granted as specified in Subsection 108.11.

The Contractor shall notify, in writing, the Utility(s) involved of the nature and scope of the Project, and of its operations that may affect their facilities or property. The notice shall include an inquiry for all information required to determine the location of the existing utility facilities and the Contractor shall also provide the portion of the approved Preliminary Schedule relative to that respective Utility. Two copies of such notices and the Utility’s responses shall be sent to the Resident Engineer prior to the start of Construction Operations. The Contractor shall also attend a Utility preconstruction conference prior to the start of Construction Operations.

The Contractor shall provide each Utility the portion of the approved Baseline CPM Schedule related to the respective Utility and any approved updates or revisions that affect that Utility.

Information on the Utility(s), including the work to be performed by the Utility(s) on the Project, will be provided in the Special Provisions.

The corporations, companies, agencies, or municipalities owning or controlling the utilities, and the name, title, address, and telephone number of their local representative are attached herein.

Bidders are advised to verify the above information as its accuracy and completeness is not guaranteed by the County.

The Contractor is advised the design for this Contract did not identify any anticipated utility conflicts. However, this Contract does require the Contractor to call the State's One Call System as specified in Subpart C., to verify a conflict does not exist.

A pre-construction meeting will be held to enable full coordination of parties involved in this project. The County will arrange this meeting shortly after award of contract and prior to the start of any work and send an agenda and written invitations to municipal officials, utility owners and any other interested parties.

A minimum of five (5) business days prior to the pre-construction meeting, the Contractor will provide the County, in writing, with the following:

- 1. Proposed work schedule;***
- 2. List of Sub-Contractors;***
- 3. List of material suppliers;***
- 4. Certificates of Compliance for all materials and or assemblies, including: Hot Mix Asphalt Pavement Markings; Signs; Pipe and any other items required under the contract;***
- 5. Breakdown of any lump-sum items;***
- 6. Shop drawings of all construction items.***

THE CONTRACTOR WILL NOT COMMENCE WORK UNTIL THE ABOVE MATERIAL IS RECEIVED & APPROVED.

SECTION 106 - CONTROL OF MATERIAL

106.07.01 Certification of Compliance

Submit manufacturer's Certifications of Compliance stating that the materials and/or assemblies fully comply with the requirements of the Contract when required by the Contract or requested by the Department.

Ensure that Manufacturer's Certification of Compliance contains the following information:

1. Project Name.
2. Name of the Contractor.
3. Material description.
4. Quantity of material represented by the certification.
5. Means of identifying the consignment, such as label marking or seal number.
6. Date and method of shipment.
7. A statement that the material conforms to the Contract material requirements and representative samples have been sampled and tested.
8. If the submission is for an assembly of materials, a statement that the assembly conforms to the Contract.
9. Signature of a person having legal authority to bind the supplier.
10. Typed or printed name of the person who signed the certification.

Before incorporating the materials into the Project, obtain three (3) copies of the manufacturer's Certifications of Compliance for materials, components, and manufactured items that are accepted by certification. Retain one (1) copy and submit two (2) copies to the RE. With the Certification of Compliance, provide a transmittal identifying the Item for which it is submitted. For products that contain steel or iron, attach additional documents as required by the certification procedures as specified in 106.07.02. The Contractor may submit the Certifications of Compliance electronically to the RE in a scanned document. Include the transmittal and all backup documentation in the scanned document.

The Department has the right to sample and test materials or assemblies accepted on the basis of Certifications of Compliance at any time. The Department will reject materials or assemblies, whether in place or not, if found not to be in conformance with the Contract requirements.

The Department will not make payment for an Item for which material is accepted on the basis of a Certification of Compliance until the RE has received the required Certification of Compliance and has inspected and accepted the material or assembly.

106.07.02 Certification for iron and steel

- A. Pre-cast Concrete Steel and Concrete Pipe Certification of Compliance.** For pre-cast concrete and concrete pipe items, a Buy America Compliance Plan is required to confirm that the material meets the Buy America requirements as specified in 106.03. The ME will periodically audit compliance with the program at the pre-cast plant. If the pre-cast concrete item is not inspected by ME, submit a Certification of Compliance for the pre-cast concrete item as required in 106.07.01. When a Certification of Compliance is submitted, ensure the Certification of Compliance contains a statement that the reinforcing steel used in the pre-cast concrete item complies with the Buy-America requirements as specified in 106.03
- B. Incidental Steel or Iron Components and Manufactured Products.** Incidental steel and iron components such as lifting hooks, tie wire, chairs, nuts, bolts and screws are not required to be certified for compliance with Buy-America requirements. For manufactured products that are not made predominantly of steel, the steel components are not required to be certified for compliance

with Buy-America requirements.

- C. Step Certification of Compliance.** For products that contain steel or iron components and are not covered in 106.07.02.A or 106.07.02.B, step Certification of Compliance is required to confirm the item meets the Buy-America requirements as specified in 106.03. A step certification is a process under which each handler (e.g., supplier, fabricator, manufacturer, processor, coating facility) of the iron and steel components certifies the steel and iron components were of domestic origin and their step in the process was domestically performed.

Every step in the process from melting to coating must be performed in the United States in order for the steel or iron component to be considered domestic and must be documented by step certification. If a domestic source for a steel or iron component cannot be found, submit a request for waiver to the Department. Do not purchase non-domestic steel or iron components without the express written consent of the Department.

Ensure three (3) copies of the Contractor's Certification of Compliance (Form DC-17) and the step Certifications of Compliance are provided for items containing steel or iron. Retain one (1) copy and submit two (2) copies to the RE. The Contractor may submit the DC-17 and the step certifications electronically in a scanned document.

Ensure step Certifications of Compliance contain the following information:

1. Name of the Company supplying the material.
2. Name and location of the Company the material was shipped to.
3. Material description.
4. Quantity of material represented by the Certification.
5. Means of identifying the consignment, such as label marking or seal number.
6. Date and method of shipment.
7. A statement that the material conforms to the Contract material requirements and to the Buy-America requirements in 106.03.
8. A statement that all steel or iron components in the material or assembly were "melted and manufactured in the US," unless there is non-domestic steel or iron in the material or assembly.
9. If there is non-domestic steel or iron in the assembly, describe in detail the non-domestic steel or iron material and the quantity. Attach a copy of the Department's approval for the use of non-domestic steel or iron components.
10. Signature of a person having legal authority to bind the supplier.
11. Typed or printed name of the person who signed the certification.

The Department will not make payment for work containing steel or iron materials until the RE has received the required DC-17 and step Certifications of Compliance and has inspected and accepted the material or assembly.

SECTION 107 - LEGAL RELATIONS

107.04 NEW JERSEY CONTRACTUAL LIABILITY ACT

THE FOURTH PARAGRAPH IS CHANGED TO:

For purposes of determining the date of “completion of the contract” pursuant to N.J.S.A. 59:13-5, “completion of the contract” occurs on the date that the Contractor provides written notice to the Department of Acceptance or conditional Acceptance of the Proposed Final Certificate or the 30th day after the Department issues the Proposed Final Certificate, whichever event occurs first.

107.09 INDEPENDENT CONTRACTOR

THE ENTIRE SUBSECTION IS CHANGED TO:

The relationship of the Contractor to the State is that of an independent contractor. Conduct business consistent with such status. Do not hold out or claim to be an officer or employee of the Department by reason hereof. Do not make a claim, demand, or application to or for the rights or privileges applicable to an officer or employee of the Department, including, but not limited to, Workers Compensation Insurance, unemployment insurance benefits, social security coverage, or retirement membership or credit.

107.11 RISKS ASSUMED BY THE CONTRACTOR

THE ENTIRE SUBSECTION IS CHANGED TO:

- 1. Risks of Loss or Damage to the Permanent Construction.** Until Acceptance, and within the limits of the Project’s work, the Contractor shall bear the risk of all loss or damage to all permanent construction and temporary construction performed under this Contract and to materials, whether or not it has received payment for such construction or materials under Subsection 109.05, 109.06, or 109.07, except payment will be made to the Contractor for the repair or replacement of any permanent element of the construction which has not been accepted by the Department, if the element of the work damaged is completed to the stage of serving its intended function and is subsequently damaged by accident by public traffic. In order to receive payment, the Contractor must supply satisfactory evidence that such damage was caused by a public traffic accident that was not caused by vandalism or by the equipment of the Contractor or any of its subcontractors or suppliers. Satisfactory evidence shall generally be limited to: accident reports filed with the Division of Motor Vehicles, police agencies or insurance companies; statements by reliable, unbiased eyewitnesses; identification of the vehicle involved in the accident. Physical evidence that the damage was caused by a motor vehicle (such as tire marks or broken headlight glass) will not be sufficient unless it can be clearly shown that the damage was not caused by the Contractor’s vehicles or by vandalism. The Contractor shall take every precaution, as allowed by the Contract against injury or damage to any part of the construction or to materials by the action of the elements, the traveling public, vandalism, or from any other cause, whether arising from the execution or the non-execution of the work. The Contractor shall promptly repair, replace, and make good any such damage or loss without cost to the Department. The Contractor shall not bear such risk of loss or damage, which arises from acts of war or floods, tidal waves, earthquakes, cyclones, tornadoes, hurricanes, or other cataclysmic natural phenomenon unless such loss or damage is covered by insurance.

THE FOLLOWING SUBSECTION IS ADDED:

107.17 COMMUNICATION WITH THE NEWS MEDIA

Do not communicate with the news media or issue a news release without obtaining a prior written approval from the Department.

SECTION 108 - PROSECUTION AND COMPLETION

108.01 SUBCONTRACTING

1. Values and Quantities.

THE FOLLOWING IS ADDED TO FIRST PARAGRAPH

1. There are no Specialty Items in this Project.

THE THIRD PARAGRAPH IS CHANGED TO:

If a partial quantity of work for a unit price Item is subcontracted, the Department will determine the value of the work subcontracted by multiplying the price of the Item by the quantity of units to be performed by the subcontractor.

THE FOURTH PARAGRAPH IS CHANGED TO:

If only a portion of work of an Item is subcontracted, the Department will determine the value of work subcontracted based on the value of the work subcontracted as indicated in the subcontract agreement and as shown in a breakdown of cost submitted by the Contractor.

108.02 COMMENCEMENT OF WORK

THE SUBPART 4 IN THE FIRST PARAGRAPH IS CHANGED TO:

4. Progress schedule as specified in 153.03

108.06 NIGHT OPERATIONS

THE FOLLOWING IS ADDED TO THE BEGINNING OF THE FIRST PARAGRAPH:

The Contractor shall be responsible for furnishing, maintaining, removal and or disposal of all equipment, material and manpower necessary for compliance with this sub-section.

2. Visibility Requirements for Workers and Equipment.

THE FIRST PARAGRAPH IS CHANGED TO:

Ensure workers wear a 360° high-visibility retroreflective safety garment meeting ANSI/ISEA Class 3, Level 2 standards.

108.07 TRAFFIC CONTROL

THE FOLLOWING IS ADDED:

Working hours for this project are as follows:

Weekdays (Monday through Friday)

Daytime 7:00 am to 4:00 pm

Weekends/Holidays

Not Allowed without Approval from Union County

108.07.01 Interference

THE FOLLOWING IS ADDED TO THIS SUB-SECTION:

It shall be the Contractor's responsibility to maintain driveway access for all adjacent property owners.

In the event industrial and commercial driveway access must be temporarily denied, the Contractor shall provide written notice to the Engineer and property owner at least five (5) working days in advance of the driveway closing.

THE CONTRACTOR SHALL BE RESPONSIBLE FOR ESTABLISHING AND MAINTAINING ALL WORK ZONES FOR THE CONSTRUCTION. ALL TRAFFIC CONTROL DEVICES AND MANPOWER NECESSARY TO MAINTAIN SUCH WORK ZONES IN ACCORDANCE WITH THE CURRENT EDITION OF THE MANUAL OF UNIFORM TRAFFIC CONTROL DEVICES SHALL BE SUPPLIED, IMPLEMENTED AND REMOVED AT THE APPROPRIATE TIME BY THE CONTRACTOR.

108.09 Maintenance within the Project Limits

The following is added to this sub-section:

The Contractor shall not be responsible for removal of ice or snow from sections of roadways opened to traffic or for damage to the project caused by the operation of snow plows or other snow removal or deicing operations carried on by others under the supervision or direction of the County. The Contractor shall not be responsible for mowing unless an item for mowing is scheduled in the proposal form. However, the Contractor shall be responsible for the removal of all leaves, debris and other material on the road, prior to reconstruction and resurfacing. The Contractor will also be responsible for street sweeping prior to resurfacing operations, and at the end of each day following milling operations.

108.11.01 Extensions to Contract Time

B. Types of Delays.

1. Non-Excusable Delays.

THE FOLLOWING IS ADDED:

For work performed by Utilities, delays up to 30 percent of the estimated duration specified in 105.07.02 are considered non-excusable. The duration includes both the advance notice and the completion of the work by the Utility.

2. Excusable, Non-Compensable Delays.

b. Utilities.

THE LAST PARAGRAPH IS CHANGED TO:

If approved excusable, non-compensable delays exceed a total of 90 days, the time in excess of 90 days will become excusable and compensable as specified in 108.11.01.B.3.

108.19 COMPLETION AND ACCEPTANCE

THE FOLLOWING IS ADDED:

No Incentive Payment for Early Completion is specified for this project.

SECTION 109 - MEASUREMENT AND PAYMENT

109.01 MEASUREMENT OF QUANTITIES

THE SECOND PARAGRAPH IS DELETED:

109.02 SCOPE OF PAYMENT

THE THIRD SENTENCE OF THE FIRST PARAGRAPH IS CHANGED TO:

The Department will not make additional or separate payment for work or portion of work unless specifically provided for in the "Measurement and Payment" Subsection.

109.05 ESTIMATES

THE SECOND PARAGRAPH IS CHANGED TO:

The RE will provide a summary of the Estimate to the Contractor. Before the issuance of each payment, certify, on forms provided by the Department, that:

- Each subcontractor or supplier has been paid the amount due from the previous progress payment and shall be paid the amount due from the current progress payment and that full payment for any retainage withheld from a subcontractor has been or will be made within 30 days after the subcontractor's work has been satisfactorily completed; or
- There exists a valid basis under the terms of the subcontractor's or supplier's contract to withhold payment from the subcontractor or supplier, and therefore payment is withheld.

THE TENTH PARAGRAPH IS CHANGED TO:

The RE has the right to not process an Estimate when, in the judgment of the RE, the Work is not performed or proceeding as specified in the Contract or following the Department giving the Contractor and Surety notice of default as specified in 108.14.

DIVISION 150 - CONTRACT REQUIREMENTS

SECTION 151 - PERFORMANCE BOND AND PAYMENT BOND

151.04 MEASUREMENT AND PAYMENT

THE FOLLOWING IS ADDED:

Payment will not be made for Performance Bond and Payment Bond. All costs thereof shall be included within the various bid pay items.

SECTION 152 - INSURANCE

152.03.01 Owner's and Contractor's Protective Liability Insurance

A. Policy Requirements.

THE FOURTH SENTENCE OF THE FIRST PARAGRAPH IS CHANGED TO:

Ensure policies are underwritten by companies with a current A.M. Best rating of A- with a Financial Size Category of VII or better.

152.04 MEASUREMENT AND PAYMENT

THE FOLLOWING IS ADDED:

Payment will not be made for insurance of any kind. All costs thereof shall be included within the various bid pay items.

SECTION 153 - PROGRESS SCHEDULE

153.03.02 CPM Progress Schedule Updates

THE LAST PARAGRAPH IS CHANGED TO:

If the project falls behind schedule for non-excusable delays, so the schedule indicates the Work will not be completed by the Completion date, as specified in 108.10, take the necessary steps to improve progress. Under such circumstances, the RE may direct the Contractor to increase the number of shifts, begin overtime operations, work extra days, including weekends and holidays, and supplement its construction plant. Furthermore, the RE may require the Contractor to submit for approval a recovery schedule showing how the Contractor proposes to meet the directed acceleration.

2. Tabular Reports.

THE FIRST SENTENCE OF THE FIRST PARAGRAPH IS CHANGED TO:

The RE may require three (3) color paper copies of the longest path sort, total float sort, responsibility sort, area sort, and Gantt chart.

153.03.03 Bar Chart Progress Schedule and Updates

A. Schedule.

THE THIRD SENTENCE OF THE THIRD PARAGRAPH IS CHANGED TO:

Provide three (3) color paper copies of a bar chart progress schedule or similar type that is acceptable to the RE for approval as follows:

THE FOLLOWING IS ADDED:

If the project falls behind schedule for non-excusable delays, so the schedule indicates the Work will not be completed by the Completion date, as specified in 108.10, take the necessary steps to improve progress. Under such circumstances, the RE may direct the Contractor to increase the number of shifts, begin overtime operations, work extra days, including weekends and holidays, and supplement its construction plant. Furthermore, the RE may require the Contractor to submit for approval a recovery schedule showing how the Contractor proposes to meet the directed acceleration.

153.04 MEASUREMENT AND PAYMENT

THE FOLLOWING IS ADDED:

Payment will not be made for Project Schedules of any kind including updates. All costs thereof shall be included within the various bid pay items.

THE THIRD PARAGRAPH IS CHANGED TO:

If the Contractor's CPM Progress Schedule update is not approved by the date of the progress meeting for the following update, the Department will assess liquidated damages to recover the Department's increased administrative costs.

SECTION 157 - CONSTRUCTION LAYOUT AND MONUMENTS

157.03.01 CONSTRUCTION LAYOUT

THE SEVENTH PARAGRAPH IS CHANGED TO:

Provide the Utilities with the layout needed to install relocated utility facilities and coordinate the Work. Ensure relocated facilities do not conflict with proposed construction, including High Voltage Proximity Act conflicts.

157.03.01 MEASUREMENT AND PAYMENT

THE FOLLOWING IS ADDED:

Payment will not be made for Construction Layout. All costs thereof shall be included within the various bid pay items.

**SECTION 158 - SOIL EROSION AND SEDIMENT CONTROL AND WATER
QUALITY CONTROL**

158.04 MEASUREMENT AND PAYMENT

THE PAY ITEM CONCRETE WASHOUT SYSTEM IS DELETED AND THE FOLLOWING IS ADDED:

Separate payment will not be made for Concrete Washout System, but the costs shall be included in the various items of the proposal.

SECTION 159 - TRAFFIC CONTROL

THE FOLLOWING IS ADDED AFTER THE FIRST PARAGRAPH:

ALL WORKERS SHALL WEAR REFLECTORIZED GARMENTS, UTILIZING 360° VISIBILITY, AS SPECIFIED FOR TRAFFIC DIRECTORS.

THE CONTRACTOR SHALL BE RESPONSIBLE FOR ESTABLISHING AND MAINTAINING ALL WORK ZONES FOR THE CONSTRUCTION. ALL TRAFFIC CONTROL DEVICES WITHIN WORK ZONES SHALL BE ESTABLISHED IN ACCORDANCE WITH THE LATEST EDITION OF THE MANUAL OF UNIFORM TRAFFIC CONTROL DEVICES. ALL TRAFFIC CONTROL MEASURES SHALL BE SUPPLIED, IMPLEMENTED AND REMOVED AT THE APPROPRIATE TIME BY THE CONTRACTOR.

All traffic control devices shall comply with these Specifications and the Standard Details for Traffic Control Devices as developed by the New Jersey Department of Transportation.

All traffic control devices furnished by the Contractor shall be new, or in acceptable condition as defined by the American Traffic Safety Services Association (ATSSA), Quality Standards For Work Zone Traffic Control Devices - 3rd Edition. Traffic control devices damaged under this Contract as a result of carelessness or mishandling by the Contractor (i.e., running over cones or barrels with his equipment or splashing tar on traffic control devices, etc.) shall be replaced by the Contractor at no additional cost to the County. The Contractor shall replace damaged traffic control devices within one (1) calendar day. The County reserves the right to reject any traffic control device, which in their sole opinion does not satisfy the criteria of these Specifications, is damaged or otherwise incapable of providing the function for which it was intended. In this event, the Contractor shall replace the deficient traffic control devices and/or materials within one (1) calendar day. Upon completion of the Project, all traffic control devices and materials furnished by the Contractor shall be removed by the Contractor.

All signs furnished by the Contractor shall conform to the latest addition Manual of Uniform Traffic Control Devices and the U.S.D.O.T. Manual of Standard Highway Signs. *All signs and traffic control devices shall be manufactured with, or incorporate 3M diamond grade material or approved equal. All signs shall be aluminum, with a thickness of 0.100 inches, and cut to Standard sizes.*

Should the Contractor begin work prior to the work zone being properly established as described herein, the County shall assume no responsibility for tort liability issues arising from the Contractor's premature start. All liability and consequence arising from a premature start is solely the Contractor's.

In the event the manhole, inlet or other appurtenance is in the middle of a travel way and the placement of a traffic device would impede the flow of traffic, the manhole, inlet or other appurtenance will be ramped in accordance with Construction Details with fresh hot mix asphalt material (either cold or hot mix). The use of millings to perform this operation will not be allowed.

159.03.01 TRAFFIC CONTROL COORDINATOR

THE FOLLOWING IS ADDED:

The Contractor shall be responsible for project maintenance within the project limits until acceptance. This maintenance shall consist of continuous and effective work prosecuted day by day, with adequate equipment and forces to the end that the roadway is kept in satisfactory condition at all times. In the case

of a contract requiring the placing of a course upon a course or subgrade previously constructed, the Contractor shall maintain the previous course or subgrade during all construction operations.

Prior to the start of construction operations, the Contractor shall assign a supervisory-level employee to be the Traffic Control Coordinator. The Engineer and affected municipalities shall be notified as to the name and telephone number of this individual on a 24-hour, 7-day a week basis. **A PAGER NUMBER FOR THIS PURPOSE WILL NOT SUFFICE. IF AND WHEN THE NUMBER IS CALLED, THE CONTRACTOR OR DULY APPOINTED AGENT MUST BE AVAILABLE TO ANSWER AND RESPOND TO THE EMERGENCY CALL. THE CONTRACTOR'S RESPONSE TIME TO EMERGENCIES THAT ARISE DURING THIS PROJECT SHALL BE WITHIN ONE (1) HOUR.**

The Traffic Control Coordinator shall be responsible for ensuring the Contractor meets all provisions of the current edition of the Manual on Uniform Traffic Control Devices, OSHA, ANSI and Title 39 – Uniform Motor Vehicle Laws of New Jersey. The Traffic Control Coordinator shall be the liaison between the Contractor and County for the duration of the project. It will be his/her responsibility to notify the Engineer when and where the Contractor's work force and equipment shall be throughout the workday. The Traffic Control Coordinator is responsible for the following:

- Ensuring all Contractor equipment and vehicles are properly stored and parked so as not to create a traffic hazard;
- Coordinating the Contractor's work schedule and need for traffic directors with the Engineer or duly appointed representative with regards to the maintenance and protection of traffic;
- Confirming the Contractor's compliance and cooperation with the Engineer with regards to the maintenance and protection of traffic;
- Repositioning of traffic control devices displaced by traffic or construction equipment;
- Notifying County forces of damaged traffic control devices;
- Confirming all traffic control devices moved or repositioned by the Contractor or his forces are placed in their original position;
- Coordinating all Concrete Construction Work Zones, including signage, traffic control devices and the appropriate manpower.

The Contractor shall be responsible for maintaining safe and adequate pedestrian access in, near or around the work site. Neither the Contractor's equipment nor debris and materials shall occupy any part of the sidewalk, path or traveled way not being constructed.

All equipment, materials, excavated material or debris shall be removed by the end of the workday. Material or debris left at the end of the day by the Contractor on, near or adjacent to the sidewalk or traveled way that is open to pedestrians and vehicles is subject to removal by the County forces. In this event, the costs associated with the removal will be deducted from monies owed the Contractor.

159.03.02 Traffic Control Devices

THE FOLLOWING IS ADDED AFTER THE FIRST PARAGRAPH:

Traffic Control devices shall be NCHRP-350 crash test compliant by the NJDOT and shall be duly certified, if necessary.

Newly purchased devices shall be NCHRP-350 compliant. A list of NCHRP 350 compliant and FHWA approved devices can be found at:

http://www.fhwa.dot.gov/safety/fourthlevel/pro_res_road_nchrp350.htm

4. Portable Variable Message Signs (PVMS)

THE FOLLOWING IS ADDED:

Install and activate portable variable message signs (PVMS), as directed by the County. Activate PVMS a minimum of one full week (seven [7] calendar days) in advance of the start of construction and remove PVMS upon completion of the construction. PVMS shall generally read the expected construction duration and expected delays. The actual messages shall be provided by the County.

THE FOLLOWING SUBSECTION IS REPLACED IN ITS ENTIRETY WITH THE FOLLOWING:

6. Traffic Control Truck with Mounted Crash Cushions.

THE LAST SENTENCE IS CHANGED TO:

Submit drawings to the RE detailing the manner of securing the ballast, signed and sealed by a Professional Engineer, certifying it is capable of withstanding the impact forces for which the impact attenuator is rated. Contractor shall provide Traffic Control Truck with Mounted Crash Cushion to aid in the placement of traffic control devices, as needed for the duration of the project when directed.

159.03.06 TEMPORARY TRAFFIC STRIPES AND TEMPORARY TRAFFIC MARKINGS

THE ENTIRE TEXT IS CHANGED TO:

Apply temporary traffic stripes and markings when the ambient and surface temperatures are at least 45 °F and rising and the surface temperature is no more than 140 °F. Apply the traffic paint in a wet film thickness of 6 ± 1 mil. Apply glass beads to the wet paint in a uniform pattern and at the rate of 12 pounds per gallon of paint. Ensure TRAFFIC STRIPES and TRAFFIC MARKINGS are applied within 14 days of placing temporary traffic stripes and markings unless directed by the RE.

159.03.08 TRAFFIC DIRECTION

A. Flagger.

THE LAST SENTENCE IS CHANGED TO:

Ensure the flagger is equipped with a STOP/SLOW paddle and follows MUTCD flagging procedures.

THE FOLLOWING IS ADDED TO THIS SECTION:

Should the circumstances arise during any construction operations where the use of flaggers is not permitted by the Motor Vehicle & Traffic Laws of New Jersey, Title 39, specifically 39:4-57 and or 39:4-80 & 81, or any other section in Title 39, or in the opinion of the Engineer, where the limitations of such flaggers in the roadway do not optimize the safety of pedestrians and the motoring public, Off-Duty Police Traffic Directors shall be utilized. Under these circumstances, it shall be the Contractor's responsibility to coordinate and schedule all officers necessary for the appropriate construction phases; however, the County of Union will regulate the amount of and location of each director. The Contractor shall be responsible for paying prevailing wage rates for Police Traffic Directors, at the respective Municipal Police Department rate. Reimbursement for police traffic directors shall be based on the amount of actual person-hours provided by the respective municipalities. Reimbursement will not be made for any:

- *differential overtime rate;*
- *vehicle charges;*
- *Administration fees, & or taxes.*

Payment of such shall be included in the overall price bid for various traffic control pay items. The Contractor shall be required to produce proof of both payment & hours worked for each officer, at each post for each assignment. Should the Contractor fail to produce said proof, the County will withhold payment on this item until such time that adequate & satisfactory proof can be provided.

B. Police.

THIS SUBSECTION HAS BEEN REPLACED IN ITS ENTIRETY WITH THE FOLLOWING:

The Contractor shall coordinate with local police department from the Borough of Mountainside as to their requirements or compliance with State Law for police presence during commencement of closure and opening of the Bridge and movement of large equipment to and from the site. Contractor shall be responsible for scheduling all work and notifications with the local police to comply with local ordinance or police presences. The use of police services does not relinquish or diminish the Contractor’s responsibilities for work zone safety nor shall they serve as a substitute for traffic director flaggers. County is not responsible for interruptions or delays to construction activities resulting from any failure of police presences at the work site.

159.04 MEASUREMENT AND PAYMENT

THE FOLLOWING PAY ITEM IS ADDED:

<i>Item</i>	<i>Pay Unit</i>
TRAFFIC DIRECTOR, UNIFORM POLICE	ALLOWANCE

THE PAY ITEMS TEMPORARY PAVEMENT MARKERS, TEMPORARY PAVEMENT MARKING TAPE, TEMPORARY TRAFFIC STRIPES AND TEMPORARY TRAFFIC MARKINGS ARE DELETED AND THE FOLLOWING IS ADDED:

Separate payment will not be made for Temporary Pavement Markers, Temporary Pavement Marking Tape, Temporary Traffic Stripes and Temporary Traffic Markings, but the costs shall be included in the lump-sum bid for Maintenance and Protection of Traffic.

THIS SUB-SECTION IS AMENDED AS FOLLOWS:

The County has included an allowance cost in the bid proposal for the presence of uniform police for this project. The Contractor shall provide invoice receipt from the municipality for work performed by uniform police, as well as the municipality requirements for police presence on public roadways for construction activity in justifying payment and reimbursement.

Where Police Traffic Directors may be utilized, the Contractor shall notify the respective Police Department at least four (4) business days (96 hours) in advance of requiring the traffic directors. Should there be a difference between the Engineer’s requirement, and that of the Police Department, the Contractor shall immediately notify the Engineer and request clarification.

If the Contractor cancels any work, without prior notice to the affected Municipal Police Department, then any costs incurred from the respective Police Departments shall become the Contractor's responsibility. The Contractor shall be responsible for establishing any and all escrow accounts that may be required by the Municipal Police Department. The Contractor shall confirm specific details of hiring Traffic Directors with each respective Police Department.

Separate payment will not be made for relocating traffic control devices as required or as directed. Separate payment will not be made for posts or stands for construction signs. Separate payment will not be made for traffic control coordinator. Separate payment will not be made for moving the traffic control truck units during the various stages of construction. Separate payment will not be made for escape ramps provided at the edges of pavement lifts or at excavations. All costs thereof shall be included in the prices bid for the various Pay Items scheduled in the Bid Sheets.

All property owner notices, traffic control devices & labor necessary to maintain such work zones utilizing the necessary devices and items, other than those stipulated to be paid under a separate bid pay item shall be supplied, implemented and removed at the appropriate time by the Contractor. Separate payment will not be made for the cost of such traffic control devices, any relocation of such and associated manpower but the costs shall be included in the various items of the proposal.

SECTION 160 - PRICE ADJUSTMENTS

160.03.01 Fuel Price Adjustment

THROUGHOUT THIS SUBSECTION, TABLE 161.03.01-1 IS CHANGED TO TABLE 160.03.01-1

THE THIRD PARAGRAPH IS CHANGED TO:

If the as-built quantity of an Item listed in Table 160.03.01-1 differs from the sum of the quantities in the monthly Estimates, and the as-built quantity cannot be readily distributed among the months that the Item listed in Table 160.03.01-1 was constructed, then the Department will determine fuel price adjustment by distributing the difference in the same proportion as the Item’s monthly Estimate quantity is to the total of the Item’s monthly estimates.

THE 25TH LINE IN THE TABLE 160.03.01-1 IS CHANGED TO:

HOT MIX ASPHALT ___ ___ BASE COURSE 2.50 Gallons per Ton

160.03.02 Asphalt Price Adjustment

NOTE 1 OF THE THIRD PARAGRAPH IS CHANGED TO:

- 1. The New Jersey Department of Transportation will determine the weight of asphalt binder for price adjustment by multiplying the percentage of new asphalt binder in the approved job mix formula by the weight of the item containing asphalt binder. If a Hot Mix Asphalt item has a payment unit other than ton, the Department will apply an appropriate conversion factor to determine the number of tons used.

THE FOURTH PARAGRAPH IS CHANGED TO:

$$A = B \times [(MA - BA)/BA] \times C \times M \times G$$

Where:

A = Asphalt Price Adjustment

B = Bid Price for Tack Coat/Prime Coat

MA = Monthly Asphalt Price Index

BA = Basic Asphalt Price Index

C = Petroleum Content of the Tack Coat and Prime Coat in Percent by Volume:

Use 100% for cutbacks and Tack Coat 64-22

60% for Polymer Modified Tack Coat

60% for RS or similar type emulsions

M = Percentage of Bid Price Applicable to Materials Only: Use 82%

G = Gallons of Tack Coat and Prime Coat Furnished and Applied

160.04 MEASUREMENT AND PAYMENT

THE FOLLOWING IS ADDED TO THIS SUB-SECTION:

An Allowance for *Asphalt Price Adjustment* and *Fuel Price Adjustment* has been established in the bid proposal sheet. The allowance amount will be adjusted based on the formulas established in the specifications for calculating price adjustments if warranted.

Asphalt price adjustments will not be made for Tack Coat and Prime Coat.

SECTION 161 - FINAL CLEANUP

161.04 MEASUREMENT AND PAYMENT

THE ENTIRE SUBSECTION IS CHANGED TO:

Separate payment will not be made for Final Cleanup but the costs shall be included in various items of the proposal.

SECTION 202 - EXCAVATION

202.02 MATERIALS

THE FIRST IN THE LIST IS CHANGED TO:

Coarse Aggregate (No. 57, or 67)901.03

202.03.03 Excavating Unclassified Material

A. Excavating.

THE FIRST PARAGRAPH IS CHANGED TO:

Unclassified excavation consists of excavation and management of material of whatever nature encountered, including regulated material, pavement removal and acid producing soil.

202.03.04 Excavating Regulated Material.

THE FIRST PARAGRAPH IS CHANGED TO:

Regulated material excavation consists of excavation and management of material of whatever nature encountered that is classified as regulated or hazardous material in the NJDEP Solid Waste Regulations, N.J.A.C. 7:26-1 *et seq.* or N.J.A.C 7:26-8.

THE FIRST SENTENCE OF THE SECOND PARAGRAPH IS DELETED

3. Temporarily Storing.

THE FIRST PARAGRAPH IS CHANGED TO:

Temporarily store regulated or hazardous material in stockpiles within the Project Limits and as shown on the Plans. Construct stockpiles on polyethylene sheeting. Contain stockpiles with haybales or silt fence placed continuously at the perimeter of the stockpiles. For hazardous material, if a stockpile area is not available within the Project Limits, sample and analyze materials in-situ for disposal. Excavate and place the hazardous regulated material directly into trucks, and haul it directly to the approved disposal facility.

202.03.05 Excavating Acid Producing Soil (APS)

THE FIRST SENTENCE OF THE SECOND PARAGRAPH IS DELETED

202.03.07 Reuse or Disposal of Excess Material

A. Reuse.

THE THIRD PARAGRAPH IS CHANGED TO:

Upon RE’s approval, reuse excavated soil to widen or flatten slopes of embankment, to fade embankments into cuts, or as approved at other locations. Ensure that the excess material is not reused within a wetland, a transition area, a riparian zone, a flood hazard area or other regulated area without obtaining an appropriate NJDEP permit.

B. Disposal.

PARTS 1 AND 2 UNDER THE FIRST PARAGRAPH ARE CHANGED TO:

1. At least 10 days before disposing, submit the disposal procedure and location to the RE for approval. Do not dispose of excavation on property proposed to be used for parks, playgrounds, and other recreational purposes; residential facilities, and educational facilities; environmentally sensitive areas such as wetlands, and historic sites; or areas within sight of a State highway during all seasons.
2. Obtain the property owner's notarized authorization of the acceptance of the excess material and where it is being placed.

202.04 MEASUREMENT AND PAYMENT

THE FOLLOWING PAY ITEMS ARE DELETED:

<i>Item</i>	<i>Pay Unit</i>
PRESPLITTING	SQUARE YARD
EXCAVATION, REGULATED MATERIAL	CUBIC YARD
SOIL SAMPLING AND ANALYSES, REGULATED	UNIT
EXCAVATION, ACID PRODUCING SOIL	CUBIC YARD
SOIL SAMPLING AND ANALYSES, ACID PRODUCING SOIL	UNIT
DISPOSAL OF ACID PRODUCING SOIL	TON
DISPOSAL OF REGULATED MATERIAL	TON
DISPOSAL OF REGULATED MATERIAL, HAZARDOUS	TON
REMOVAL OF PAVEMENT	SQUARE YARD

THE FOLLOWING IS ADDED:

Disposal of asphalt and concrete will be made to an N.J.D.E.P. approved recycling facility. The Contractor shall notify the Recycle Facility to provide the County with appropriate credit for recycling.

The Department will not make payment for presplitting, but all costs shall be included in the unit price bid for the item Excavation, Unclassified.

The Department will not make payment for the excavation of regulated materials or acid-producing soils, but all costs shall be included in the unit price bid for the item Excavation, Unclassified.

The Department will not make payment for soil sampling and analyses required to complete the project, but all costs shall be included in the unit price bid for the item Excavation, Unclassified.

The Department will not make payment for removal of pavement, but all costs shall be included in the unit price bid for the item Excavation, Unclassified.

The Department will not make payment for disposal of material of whatever nature encountered, but all costs shall be included in the unit price bid for the item Excavation, Unclassified.

The Department will not make payment for sawcutting, stripping and disposal of excess, unstable or unsuitable or unusable material from Excavation, Unclassified.

The Department will measure Excavation, Unclassified in unstable areas by the cubic yard of material actually excavated in the work. The Department will make payment for Excavation, Unclassified as specified in this section.

SECTION 401 - HOT MIX ASPHALT (HMA) COURSES

401.02.01 Materials

EMULSIFIED ASPHALT UNDER TACK COAT IS REVISED TO:

Emulsified Asphalt, Grade RS-1, CRS-1, SS-1, SS-1h, Grade CSS-1 or CSS-1h.....902.01.03

401.03.02 Tack Coat and Prime Coat

TABLE 401.03.02-1 IS CHANGED TO:

Table 401.03.02-1 Tack Coat Application			
Material	Spraying Temp, °F	Gallons per Square Yard	Season
Cut-Back Asphalt:			
RC-70	120 to 190	0.05 to 0.15	Oct 15 to Apr 15
Emulsified Asphalt:			
RS-1	70 to 140	0.05 to 0.15	All year
CRS-1	125 to 185	0.05 to 0.15	All year
SS-1, SS-1h	70 to 140	0.05 to 0.15	All year
CSS-1, CSS-1h	70 to 140	0.05 to 0.15	All year

TABLE 401.03.02-2 IS CHANGED TO:

Table 401.03.02-2 Prime Coat Application			
Cut-Back Asphalt	Spraying Temp, °F	Gallons per Square Yard	Season
MC-30	85 to 150	0.1 to 0.5	Oct 15 to Apr 15
MC-70	120 to 190	0.1 to 0.5	Oct 15 to Apr 15
Emulsified Asphalt:			
CSS-1	70 to 140	0.1 to 0.50	All year

401.03.03 HMA Courses

D. Transportation and Delivery of HMA.

THE FIRST PARAGRAPH IS CHANGED TO:

Deliver HMA using HMA trucks in sufficient quantities and at such intervals to allow continuous placement of the material. Do not allow trucks to leave the plant within 1 hour of sunset unless nighttime lighting is provided as specified in 108.06. The RE will reject HMA if the HMA trucks do not meet the requirements specified in 1009.02. The RE will suspend construction operations if the Contractor fails to maintain a continuous paving operation. Before the truck leaves the plant, obtain a weigh ticket from a fully automatic scale. Before unloading, submit for each truckload a legible weigh ticket that includes the following:

1. Name and location of the HMA plant.
2. Project title.
3. Load time and date.
4. Truck number.
5. Mix designation.

6. Plant lot number.
7. Tare, gross, and net weight.

E. Spreading and Grading.

1. Longitudinal Joints.

THE FOLLOWING IS ADDED TO THIS SUB-SECTION:

When constructing the first lane, care shall be exercised in rolling so as not to displace the line and grade of the edges of the HMA. The joint in the surface course shall be offset from the lane lines by six (6) inches except for the centerline of a roadway in which the joint shall fall between the double yellow traffic stripes.

A wedge joint shall be constructed when traffic is to be maintained and lift thickness is greater than 2-¹/₄ inches. A vertical edge joint will be permitted for lift thickness 2-¹/₄ inches or less when traffic has to be maintained. For lift thickness greater than 2-¹/₄ inches and traffic is not required to be maintained, a vertical edge shall be utilized.

Longitudinal joints shall be constructed utilizing one of the following methods:

- A. Vertical Edge Joint.** The paver shall be positioned so that in spreading, the HMA material uniformly overlaps the edge of the lane previously placed by one (1) to two (2) inches and shall be left sufficiently high to allow for compaction. In general, the height of the uncompacted HMA above the compacted HMA shall be ¹/₄ inch for each 1 inch of compacted mix. The overlapped HMA material being placed in the abutting lane shall be tightly crowded (bumped) over the joint. Any material in excess of the 1- to 2-inch overlap shall be pulled away from the joint and removed instead of broadcasting onto the new mat. When compacted, the new mat at the joint shall be even or slightly higher (Maximum ¹/₈ of an inch) than the previously placed adjoining mat. If the newly compacted mat results in a depression at the joint of ¹/₈ of an inch or more lower than the previously placed adjacent HMA layer, all paving operations shall cease until corrective action is taken by the Contractor to prevent reoccurrence. For all longitudinal joints that do not meet this requirement, the Contractor shall saw joints according to dimension guidelines of Subsection 404.19 and seal with an approved sealer.
- B. Wedge Joint.** The sloped plate of the paver shall produce a wedge edge having a face slope of 3H: 1V. The plate shall be so constructed as to accommodate compacted layer thickness of two (2) to four (4) inches. The bottom of the sloped plate shall be mounted one (1) inch above the existing surface. The plate shall be interchangeable on either side of the screed. The Contractor shall maintain the wedge configuration under traffic conditions.

All loose material shall be removed from the traveled way before opening to traffic. The rolling operation of the adjoining lane shall proceed as indicated in Subpart A above, except that care shall be taken to keep coarse aggregate away from the point where the wedge meets the surface of the previously placed lane.

To assure a true line, the paver shall closely follow lines or markings placed along the joint for alignment purposes. All longitudinal joints shall be constructed parallel to the centerlines within

a tolerance of plus or minus three (3) inches for every 100 linear feet. If this tolerance is not met, the mat shall be cut back to conform. The width and depth of overlapped material shall be kept uniform at all times. Overlapped material shall be looted back, pushing the material to the edge of the cold HMA mat and directly over the joint with the hot HMA mat. In no case shall excess material be broadcast across the new layer. All excess material shall be removed.

F. Compacting

THE FOLLOWING IS ADDED TO THIS SUB-SECTION:

When compacting the longitudinal edge of the first lanes placed using the wedge joint, the breakdown roller shall not extend more than two (2) inches over the top of the sloped face of the wedge joint. The Contractor shall submit a plan, to ensure material at the wedge edge is properly seated and loose material is removed, for the Resident Engineer's approval prior to the commencement of paving operations.

Care shall be taken to prevent lateral displacement of the unconfined edge during the compaction operation. The edge of the drums of vibratory or static wheel rollers shall extend over the free edge of the mat by at least six (6) inches. When compacting the joint, while paving the adjacent lane, the roller shall be placed on the newly placed HMA and overlap the joint by a distance of approximately six (6) inches.

Alternate trips of the roller shall be terminated in stops approximately two (2) feet from the preceding stop. When paving in echelon, rollers compacting the mat behind the lead paver shall maintain approximately six (6) inches of uncompacted material adjacent to the second paver. After mix from the second paver is placed against the uncompacted edge of the mat from the first paver, the rollers shall compact the HMA on both sides of the joint.

401.04 MEASUREMENT AND PAYMENT

THE FOLLOWING IS ADDED:

The Department will make a payment adjustment for HMA air void quality by the following formula:

$$\text{Pay Adjustment} = Q \times \text{BP} \times \text{PPA}$$

Where:

BP = Bid Price

Q= Air Void Lot Quantity

PPA= air void PPA as specified in 401.03.03H.

The Department will make a payment adjustment for HMA thickness quality by the following formula:

$$\text{Pay Adjustment} = Q \times \text{BP} \times \text{PPA}$$

Where:

BP = Bid Price

Q= Thickness Lot Quantity

PPA= thickness PPA as specified in 401.03.03I

The Department will make a payment adjustment for HMA ride quality, as specified in 401.03.03J.

THE FOLLOWING IS DELETED FROM THE LIST OF PAY ITEMS:

<u>Item</u>	<u>Pay Unit</u>
POLYMERIZED JOINT ADHESIVE	LINEAR FOOT
TACK COAT	GALLON
PRIME COAT	GALLON
SAWING AND SEALING JOINTS IN HOT MIX ASPHALT OVERLAY	LINEAR FOOT

All costs thereof shall be included in the prices bid for the various Hot Mix Asphalt items.

Pay Adjustments for Air Voids, Thickness and Ride Quality will be made according to Subsections 401.03.03.H, 401.03.3.I, and 401.03.03.J, respectively.

Disposal of asphalt will be made to an N.J.D.E.P. approved recycling facility. Prior to the start of operations, the Contractor shall notify the County of the location where the asphalt will be disposed. Disposal of the asphalt will be carried out in accordance with the Standard Specifications

Hot mix asphalt material for manhole, inlet and other ramping will not be measured. No separate payment will be made for this hot mix asphalt material.

A prime coat will be applied to dense graded aggregate base prior to placement of hot mix asphalt pavement.

A tack coat will be applied to all layers of hot mix asphalt courses, prior to placement of new hot mix asphalt course. In addition, a tack coat will be applied at the edges of the new pavement between paver passes.

Separate payment will not be made for temporary hot mix asphalt pavement but the costs shall be included in the various traffic control pay items.

SECTION 606 - SIDEWALKS, DRIVEWAYS, AND ISLANDS

606.01 Description.

THE FOLLOWING IS ADDED

606.03.02 Concrete Sidewalks, Driveways, and Islands.

THE FOLLOWING IS ADDED:

The various items for Concrete Sidewalk, consists of the removal and disposal of any existing concrete, brick or hot mix asphalt walks; excavation to the proper depth all around; setting forms as required; placing a 4" stone subbase as required; and pouring and finishing of concrete sidewalk and ramp as required at each location. After the stripping of forms, each site shall be cleaned and restored to match all adjacent conditions, including topsoil and seeding as required. The unit price given by the bidder shall include all work and restoration described hereto, for this item.

Disposal of concrete and asphalt will be made to an NJDEP approved recycling facility. The Contractor shall notify the Recycle Facility to provide the County with appropriate credit for recycling. Any brick pavers removed from the project shall be delivered to the respective Municipal Department of Public Works whence the material originated from.

New sidewalk shall meet existing sidewalk, at an existing or newly formed joint. The Contractor shall include the cost of all expansion joint materials in the unit prices.

Concrete for Concrete Sidewalks, shall be Gray, Class B, 4500 psi, 6% air-entrained, unless otherwise specified.

Concrete sidewalks shall be constructed in 4 ft. x 4 ft. squares using approved separators. An expansion joint shall be placed at 12-foot intervals. A four-inch layer of *¾-inch clean stone subbase* shall be placed immediately below the new concrete sidewalk. This 4-inch subbase shall be constructed in accordance with Section 301, except that payment will not be made this layer. The preparation and compaction of the subbase shall be made part of the unit price bid for the Concrete Sidewalk item.

E. Expansion Joints

THIS SUB-SECTION PART E IS CHANGED AS FOLLOWS:

Expansion joints shall be ½-inch wide, placed at intervals of approximately 12 feet, and shall be filled with preformed joint filler.

H. Protection and Curing

THE LAST SENTENCE IS CHANGED TO:

Ensure vehicles and other loads are not placed on sidewalks, islands, and driveways until the concrete has attained compressive strength of 3000 pounds per square inch, as determined from two (2) concrete cylinders field cured according to AASHTO T 23.

606.04 MEASUREMENT AND PAYMENT

THE FOLLOWING IS ADDED:

The Contractor shall include the cost of all sidewalk, driveway, apron and brick removal, excavation, material disposal, expansion joint material, reinforcement material (where necessary & directed by the Engineer), curing material, adjacent site restoration, and all other material necessary for the construction of driveway aprons and various types of sidewalk including dense graded aggregate below the sidewalk and aprons, in the cost of the various items which they are a part thereof. The unit price bid for these items shall include all work described heretofore for these items.

SECTION 607 - CURBS

607.01 DESCRIPTION

THE FOLLOWING IS ADDED:

These items shall consist of the removal and disposal of various types of curb, including: concrete, Belgian block, combination curb & gutter; and or hot mix asphalt concrete curb; excavation to the proper depth; setting forms as required; placing 6" stone base as required; and pouring and finishing of concrete curb and granite as required at each location, all in the process of constructing new curb. After the stripping of forms, each site will be cleaned and restored to match all adjacent conditions, including adjoining turf repair strips in accordance with Section 805.

607.03.02 Concrete Vertical Curb and Concrete Sloping Curb

C. Installing Joints

The following is added to this sub-Section:

Expansion joints shall be provided opposite joints in abutting concrete surface course and at approximately equal distances of not more than **10** feet between joints. Joints shall be filled with preformed expansion joint filler, ½ inch thick, which shall be flush with the top and face. Between concrete curbs and concrete surface or base course, ½-inch, preformed, expansion-joint filler shall be installed and the joint shall be sealed with hot-poured joint sealer.

All materials and equipment necessary to complete the type of curb installation described in Section 607.03.02, where necessary, will also be included in the overall payment for this Item.

D. Placing Concrete.

THE ENTIRE TEXT IS CHANGED TO:

Place concrete for vertical curb and sloping curb as specified in 607.03.01.D, except that consolidation may be achieved by hand spading or internal mechanical vibrators.

607.03.04 Concrete Vertical Curb and Concrete Sloping Curb, Dowelled

D. Placing Concrete.

THE ENTIRE TEXT IS CHANGED TO:

Place concrete for vertical and sloping curb as specified in 607.03.02.D.

607.04 MEASUREMENT AND PAYMENT

THE FOLLOWING IS ADDED:

The Contractor shall include the cost of all curb removal, concrete gutter removal, excavation, material disposal, expansion joint material, curing material, adjacent site restoration and dowels (where required) in the cost of the curbs. All curbs shall be depressed at ADA curb ramps, in accordance with the respective construction details, included in these specifications. All materials, labor & equipment

necessary to complete this work shall be included in the unit price bid for the curb item. The unit price bid for this item shall include all work described heretofore.

SECTION 653 - GAS

653.04 MEASUREMENT AND PAYMENT

THIS SUB-SECTION IS CHANGED AS FOLLOWS:

The item *Reset Gas Valve Box* shall not be measured, and no separate payment will be made. All costs shall be included in the various items of the proposal.

SECTION 804 - TOPSOILING

804.04 MEASUREMENT AND PAYMENT

THE FOLLOWING PAY ITEM IS ADDED:

<i>Item</i>	<i>Pay Unit</i>
TOPSOIL SPREADING, 4" THICK	SY

THE PAY ITEMS TOPSOILING, 4" THICK AND BORROW TOPSOIL ARE DELETED AND THE FOLLOWING IS ADDED:

Separate payment will not be made for Borrow Topsoil but the cost shall be included in the pay item Topsoil Spreading, 4" Thick.

SECTION 901 - AGGREGATES

901.10.03 Virgin and RAP Mixture

3. Density Control

THE FOLLOWING IS ADDED:

When AASHTO T 310 (Direct Transmission Method, nuclear gauge method for measuring density and moisture content) is used to perform Compaction Acceptance Testing (Subsection 302.03.01), **a representative sample of five tests for each 5,000 square yards lot will be taken.**

SECTION 902 - ASPHALT

902.02.02 Composition of Mixtures

TABLE 902.02.02-2 IS CHANGED TO:

Table 902.02.02-2 Additional Fine Aggregate Requirements for HMA		
Tests	Test Method	Minimum Percent
Uncompacted Void Content of Fine Aggregate	AASHTO T 304, Method A	45
Sand Equivalent	AASHTO T 176	45

902.02.04 Sampling and Testing

B. Sampling.

THIS ENTIRE PART IS CHANGED TO:

The ME will take a random sample from each 700 tons of production for volumetric acceptance testing and to verify composition. The ME will perform sampling according to AASHTO T 168, NJDOT B-2, or ASTM D 3665.

902.03.02 Mix Design

THE FOLLOWING IS ADDED TO THIS SUB-SECTION:

UNLESS OTHERWISE APPROVED BY THE ENGINEER, ONLY ONE SOURCE OF SUPPLY FOR HOT MIX ASPHALT MATERIAL MAY BE USED ON THE PROJECT.

THE FOURTH PARAGRAPH IS CHANGED TO:

The ME will test two (2) specimens to verify the final JMF produces a mixture that has a minimum void content as specified in Table 902.03.03-1. The ME will determine percent air voids according to AASHTO T 209, and either NJDOT B-6 or AASHTO T 331.

902.03.03 Sampling and Testing

THE FOLLOWING IS ADDED TO THE FIRST PARAGRAPH:

Ensure the mix meets the requirements as specified in 902.02.04.A, otherwise the RE or ME will reject the material.

THE SECOND PARAGRAPH IS CHANGED TO:

During production, the ME will take one random acceptance sample from each 700 tons of production to verify composition. Conduct air voids and drain down tests as directed by the ME.

THE FOURTH PARAGRAPH IS CHANGED TO:

The ME will perform sampling according to NJDOT B-2 or ASTM D 3665, and will perform testing for composition according to AASHTO T 308 or NJDOT B-5. Perform testing for air voids according to AASHTO T 209 and either NJDOT B-6 or AASHTO T 331. Perform testing for drain down according to NJDOT B-7 or NJDOT B-8.

902.04.03 Sampling and Testing

THE FIRST PARAGRAPH IS CHANGED TO:

Ensure the mix meets the requirements as specified in 902.02.04.A, otherwise the RE or ME will reject the material. Maintain the temperature of the mix between 300 °F and 330 °F. Perform and meet requirements for quality control testing as specified in 902.02.04.C.

THE SECOND PARAGRAPH IS CHANGED TO:

During production, the ME will take one random acceptance sample from each 700 tons of production to verify composition. Conduct drain down tests as directed by the ME.

902.05.01 Composition of Mixture

THE FIFTH PARAGRAPH IS CHANGED TO:

For fine aggregate, use stone sand conforming to 901.05.02. Ensure the combined fine aggregate in the mixture conforms to the requirements in Table 902.02.02-2.

902.05.02 Mix Design

THE FIRST PARAGRAPH IS CHANGED TO:

Design the SMA to meet the requirements in Table 902.05.02-1 and Table 902.05.02-2. Prepare the JMF according to AASHTO R 46. Determine the JMF at four (4) percent air voids and 75 gyrations of the Superpave gyratory compactor.

TABLE 902.05.02-2 IS CHANGED TO:

Table 902.05.02-2 SMA Mixtures Volumetric For Design and Plant Production		
Property	Production Control Tolerances	Requirement
Air Voids	±1%	4.0%
Voids in Mineral Aggregate (VMA)	–	17.0% minimum
VCA _{mix}	–	Less than VCA _{dry}
Drain down @ production temperature	–	0.30% maximum
Asphalt Binder Content (NJDOT B-5)	±0.15%	6% minimum
Asphalt Binder Content (AASHTO T 308)	±0.40%	6% minimum
Tensile Strength Ratio (AASHTO T 283)	–	80% minimum

902.05.03 Sampling and Testing

THE FOLLOWING IS ADDED TO THE FIRST PARAGRAPH:

Ensure the mix meets the requirements as specified in 902.02.04.A, otherwise the RE or ME will reject the material.

THE SECOND PARAGRAPH IS CHANGED TO:

During production at the plant, the ME will take a sample from each 700 tons of production to verify composition and air voids. Conduct drain down, VCAmix, VCAdry, and VMA testing as directed by the ME. Perform tests according to AASHTO R 46.

THE FOURTH PARAGRAPH IS CHANGED TO:

The ME will perform sampling according to NJDOT B-2 or ASTM D 3665, and will perform testing for composition according to AASHTO T 308, or NJDOT B-5. The ME will determine bulk specific gravity of the compacted sample according to AASHTO T 166 or AASHTO T 331. The ME will use the most current QC maximum specific gravity test result, obtained according to AASHTO T 209, in calculating the volumetric properties of the SMA. Perform testing for drain down according to AASHTO T 305.

902.06.03 Sampling and Testing

THE FOLLOWING IS ADDED TO THE FIRST PARAGRAPH:

Ensure the mix meets the requirements as specified in 902.02.04.A, except that the temperature of the mix at discharge is required to be between 230 °F and 275 °F, otherwise the RE or ME will reject the material.

THE SECOND PARAGRAPH IS CHANGED TO:

During production, the ME will take one random acceptance sample from each 700 tons of production to verify composition. Conduct drain down tests as directed by the ME.

SECTION 905 - REINFORCEMENT METALS

905.01 REINFORCEMENT STEEL

THE ENTIRE SUBPART IS CHANGED TO:

Provide reinforcement steel manufactured at an AASHTO NTPEP (National Transportation Product Evaluation Program) certified mill. For a list of NTPEP certified mills, see the following webpage: <http://data.ntpep.org/Module/REBAR/Overview.aspx>.

For reinforcement steel, submit a certification of compliance as specified in 106.07. Attach copies of the mill certifications for each heat of reinforcement steel. The ME will randomly sample and test heats of reinforcement steel for quality assurance. The ME will randomly inspect and sample galvanized and epoxy coated reinforcement steel for quality assurance.

905.01.03 Welded Wire Reinforcement

THE SECOND PARAGRAPH IS CHANGED TO:

When approved as an alternate to galvanized reinforcement bars, use galvanized welded wire reinforcement that meets the requirements of ASTM A 641, Table 1, Class 1.

905.01.05 Dowels

THE ENTIRE SUBPART IS CHANGED TO:

Use plain reinforcement bars according to ASTM A 615, Grade 60. Galvanize according to ASTM A 123.

905.03.03 Dowel Bars

THE FIRST PARAGRAPH IS CHANGED TO:

For dowel bars in transverse joints, use epoxy-coated, Grade 60, plain reinforcement steel according to ASTM A 615. If shown on the Plans, use dowel bars fitted with end caps. Ensure the end caps are non-metallic and designed to prevent the entrance of grout or mortar into the expansion void.

SECTION 1009 - HMA PLANT EQUIPMENT

1009.01 HMA PLANT

A. Requirements for HMA Mixing Plants.

THE FOLLOWING IS ADDED AFTER THE SECOND PARAGRAPH:

The HMA producer is required to have a quality control (QC) program plan approved annually by the ME as per Materials Approval Procedure MAP-102. The HMA producer is required to ensure that the QC plan conforms to the requirements outlined in the report entitled “Hot Mix Asphalt Quality Control Program Plan” prepared by the Department of Transportation and New Jersey Asphalt Paving Association. Failure to follow these requirements will result in rejection of HMA materials supplied by the HMA producer and removal of the HMA supplier from the QPL.

END TECHNICAL SPECIFICATIONS



STATE OF NEW JERSEY
Department of Labor and Workforce Development
Division of Wage and Hour Compliance - Public Contracts Section
PO Box 389
Trenton, NJ 08625-0389

PREVAILING WAGE RATE DETERMINATION

The New Jersey Prevailing Wage Act (N.J.S.A. 34:11-56.25 et seq.) requires that the Department of Labor and Workforce Development establish and enforce a prevailing wage level for workers engaged in public works in order to safeguard their efficiency and general well being and to protect them as well as their employers from the effects of serious and unfair competition.

Prevailing wage rates are wage and fringe benefit rates based on the collective bargaining agreements established for a particular craft or trade in the locality in which the public work is performed. In New Jersey, these rates vary by county and by the type of work performed.

Applicable prevailing wage rates are those wages and fringe benefits in effect on the date the contract is awarded. All pre-determined rate increases listed at the time the contract is awarded must also be paid, beginning on the dates specified. Rates that have expired will remain in effect until new rates are posted.

Prevailing Wage Rate

The prevailing wage rate for each craft will list the effective date of the rate and the following information:

W = Wage Rate per Hour **B** = Fringe Benefit Rate per Hour* **T** = Total Rate per Hour

* Fringe benefits are an integral part of the prevailing wage rate. Employers not providing such benefits must pay the fringe benefit amount directly to the employee each payday. Employers providing benefits worth less than the fringe benefit amount must pay the balance directly to the employee each payday.

Unless otherwise stated in the Prevailing Wage Rate Determination, the fringe benefit rate for overtime hours remains at the straight time rate.

When the Overtime Notes in the Prevailing Wage Rate Determination state that the overtime rates are "inclusive of benefits," the benefit rate is increased by the same factor as the wage rate (i.e. multiplied by 1.5 for time and one-half, multiplied by 2 for double time, etc.).

Apprentice Rate Schedule

An "apprentice" is an individual who is registered with the United States Department of Labor - Office of Apprenticeship and enrolled in a certified apprenticeship program during the period in which they are working on the public works project.

The apprentice wage rate is a percentage of the journeyman wage rate, unless otherwise indicated. The apprentice benefit rate is the full journeyman benefit rate, unless otherwise indicated.

If there is no apprentice rate schedule listed, the individual must be paid at least the journeyman rate even if that individual is in a certified apprentice program for that trade.

If there is no ratio of apprentices to journeymen listed for a particular craft, then the ratio shall be one (1) apprentice to every four (4) journeymen.

Comments/Notes

For each craft listed there will be comments/notes that cover the definition of the regular workday, shift differentials, overtime, recognized holidays, and any other relevant information.

Public Works Contractor Registration

The Public Works Contractor Registration Act (N.J.S.A. 34:11-56.48, et seq.) requires that **all** contractors, subcontractors, or lower tier subcontractors who are working on or who bid on public works projects register with the Department of Labor and Workforce Development. Applications are available at www.nj.gov/labor (click on Wage & Hour and then go to Registration & Permits).

Pursuant to N.J.S.A. 34:11-56.51:

No contractor shall bid on any contract for public work as defined in section 2 of P.L.1963, c. 150 (C.34:11-56.26) unless the contractor is registered pursuant to this act. No contractor shall list a subcontractor in a bid proposal for the contract unless the subcontractor is registered pursuant to P.L.1999, c.238 (C.34:11-56.48 et seq.) at the time the bid is made. No contractor or subcontractor, including a subcontractor not listed in the bid proposal, shall engage in the performance of any public work subject to the contract, unless the contractor or subcontractor is registered pursuant to that act.

Snow Plowing

Snow plowing contracts are not subject to the New Jersey Prevailing Wage Act or the Public Works Contractor Registration Act.

**NEW JERSEY DEPARTMENT OF LABOR AND WORKFORCE DEVELOPMENT
PREVAILING WAGE RATE DETERMINATION**

County - UNION

Craft: Air Conditioning & Refrigeration - Service and Repair

PREVAILING WAGE RATE

	03/01/20
Journeyman (Mechanic)	W40.33 B25.67 T66.00

Craft: Air Conditioning & Refrigeration - Service and Repair

APPRENTICE RATE SCHEDULE

INTERVAL	PERIOD AND RATES									
As Shown	1st Year	2nd Year	3rd Year	4th Year	5th Year	Wage = %	of Jnymn	Wage		
Wage and Bene	40%	50%	60%	70%	80%	Bene = %	of Jnymn	Bene		

Ratio of Apprentices to Journeymen - 1:4

Craft: Air Conditioning & Refrigeration - Service and Repair

COMMENTS/NOTES

THESE RATES MAY BE USED FOR THE FOLLOWING:

- Service/Repair/Maintenance Work to EXISTING facilities.
- Replacement or Installation of air conditioning and refrigeration equipment when the combined tonnage does not exceed 15 tons for refrigeration, or 25 tons for air conditioning.
- Replacement or Installation of "packaged" or "unitary" rooftop-type units when the combined tonnage of the units does not exceed 75 tons.

NOTE: These rates may NOT be used for any work in new construction (including work on new additions).

The regular workday shall consist of 8 hours, starting between 6:00 AM and 10:00 AM, Monday through Friday.

SHIFT DIFFERENTIALS:

- The second and third shifts shall be paid an additional 15% of the hourly rate.
- All shifts must run for a minimum of 5 consecutive days.

OVERTIME:

Hours worked in excess of 8 per day or before or after the regular workday, that are not shift work, and all hours on Saturday shall be paid at time and one-half the hourly rate, inclusive of benefits. All hours on Sunday and holidays shall be paid at double the hourly rate, inclusive of benefits.

RECOGNIZED HOLIDAYS: New Year's Day, Presidents' Day, Memorial Day, July 4th, Labor Day, Veterans' Day, Thanksgiving Day, Christmas Day.

**NEW JERSEY DEPARTMENT OF LABOR AND WORKFORCE DEVELOPMENT
PREVAILING WAGE RATE DETERMINATION**

County - UNION

Craft: Boilermaker PREVAILING WAGE RATE

	01/01/20
Foreman	W50.88 B45.21 T96.09
General Foreman	W52.88 B46.22 T99.10
Journeyman	W45.88 B43.54 T89.42

Craft: Boilermaker APPRENTICE RATE SCHEDULE

INTERVAL	PERIOD AND RATES									
	65%	70%	75%	80%	85%	90%	95%			
1000 Hours										
Benefit =	37.08	37.99	39.49	39.84	40.78	41.70	42.61			

Ratio of Apprentices to Journeymen - *

* 1 apprentice will be allowed for the first 5 journeymen, 1 apprentice for the next 10 journeymen and 1 apprentice for each succeeding 20 journeymen up to a maximum of 5 apprentices per contractor on any one job.

Craft: Boilermaker COMMENTS/NOTES

HIGH WORK: All apprentices working on the erection, repair, or dismantling of smoke stacks, standpipes, or water towers shall be paid the Journeyman rate.

The regular workday shall consist of 8 hours, between 8:00 AM and 4:30 PM.

SHIFT DIFFERENTIALS:

- The second shift shall work 7½ hours and receive 8 hours pay, at a rate equal to the regular hourly rate plus 10%.
- The third shift shall work 7 hours and receive 8 hours pay, at a rate equal to the regular hourly rate plus 20%.
- For "Municipal Water Works" projects only, the following shall apply: Two, four day, 10 hour shifts may be worked at straight time Monday through Thursday. The day shift shall work four days, at 10 hours, for 10 hours pay. The second shift shall work four days, at nine and a half hours, for 10 hours pay, plus 10% the hourly rate for new work and .25 cents on repair work. Friday may be used as a make-up day at straight time, due to weather conditions, holiday or any other circumstances beyond the employer's control.

OVERTIME:

- Hours in excess of 8 per day, Monday through Friday, and all hours on Saturdays shall be paid at time and one-half the hourly rate. All hours on Sundays and holidays (except Labor Day) shall be paid at double the hourly rate. All hours on Labor Day shall be paid at four times the hourly rate.
- If any other craft employed by the same contractor, or a subcontractor thereof, receives double time in lieu of time and one-half, then the Boilermaker shall receive double time in lieu of time and one-half.
- For "Municipal Water Works" projects only, the following shall apply: Four 10 hour days may be worked Monday through Thursday at straight time. Friday may be used as a make-up day for a day lost to inclement weather, holiday or other conditions beyond the control of the employer. Overtime shall be paid for any hours that exceed 10 hours per day or 40

**NEW JERSEY DEPARTMENT OF LABOR AND WORKFORCE DEVELOPMENT
PREVAILING WAGE RATE DETERMINATION**

County - UNION

hours per week.

RECOGNIZED HOLIDAYS: New Year's Day, Washington's Birthday, Memorial Day, July 4th, Labor Day, Presidential Election Day, Veterans' Day, Thanksgiving Day, Christmas Day. Sunday holidays observed the following Monday.

**NEW JERSEY DEPARTMENT OF LABOR AND WORKFORCE DEVELOPMENT
PREVAILING WAGE RATE DETERMINATION**

County - UNION

Craft: Boilermaker - Minor Repairs

PREVAILING WAGE RATE

	01/01/20
Foreman	W33.62 B16.47 T50.09
General Foreman	W34.12 B16.47 T50.59
Mechanic	W32.12 B16.47 T48.59

Craft: Boilermaker - Minor Repairs

COMMENTS/NOTES

NOTE: These rates apply to MINOR REPAIR WORK ONLY (repair work in the field for which the contract amount does not exceed \$125,000.00), for boilers that do not produce electric or are not used in the heating of petroleum products.

OVERTIME:

Hours in excess of 8 per day, Monday through Friday, and all hours on Saturdays shall be paid at time and one-half the hourly rate. All hours on Sundays and holidays (except Labor Day) shall be paid at double the hourly rate. All hours on Labor Day shall be paid at four times the hourly rate.

RECOGNIZED HOLIDAYS: New Year's Day, Washington's Birthday, Good Friday, Memorial Day, July 4th, Labor Day, Presidential Election Day, Thanksgiving Day, day after Thanksgiving, Christmas Day. Saturday holidays observed the preceding Friday, Sunday holidays observed the following Monday.

**NEW JERSEY DEPARTMENT OF LABOR AND WORKFORCE DEVELOPMENT
PREVAILING WAGE RATE DETERMINATION**

County - UNION

Craft: Bricklayer, Stone Mason

PREVAILING WAGE RATE

	10/01/20
Deputy Foreman	W47.45 B33.73 T81.18
Foreman	W50.45 B33.73 T84.18
Journeyman	W44.45 B33.73 T78.18

Craft: Bricklayer, Stone Mason

APPRENTICE RATE SCHEDULE

INTERVAL	PERIOD AND RATES									
	40%	50%	55%	60%	65%	70%	75%	80%		
6 Months										
Benefits	4.00	5.00	5.50	6.00	22.17	23.66	25.14	26.62		

Ratio of Apprentices to Journeymen - 1:5

Craft: Bricklayer, Stone Mason

COMMENTS/NOTES

The regular workday shall consist of 8 hours, between 6:00 AM and 4:30 PM.

SHIFT DIFFERENTIALS:

- When a 2 shift schedule (including a day shift) is established, the first, or day shift, shall be established on an 8 hour basis. The second shift shall be established on an 8 hour basis, and receive the regular rate plus 10%, inclusive of benefits.
- When a three shift schedule is established, the first shift shall be established on an 8 hour basis, the second shift on a 7.5 hour basis, and the third shift on a 7 hour basis. The first shift shall receive the regular hourly rate, the second shift shall receive the regular rate plus 10%, inclusive of benefits, and the third shift shall receive the regular rate plus 15%, inclusive of benefits.
- When there is no day shift, and a second or third shift is established, it shall be established on an 8 hour basis. The second shift shall receive the regular rate plus 10%, inclusive of benefits, and the third shift shall receive the regular rate plus 15%, inclusive of benefits.
- When an irregular shift must be established, this shift shall receive the regular rate plus 10%, inclusive of benefits.

OVERTIME:

- The first 2 hours in excess of 8 per day, or before or after the regular workday that are not shift work, Monday through Friday, shall be paid at time and one-half the regular rate, inclusive of benefits. Any additional overtime shall be paid at double the regular rate, inclusive of benefits. The first 10 hours on Saturday shall be paid at time and one-half the regular rate, inclusive of benefits. Any additional overtime shall be paid at double the regular rate, inclusive of benefits. All hours on Sundays and holidays shall be paid at double the regular rate, inclusive of benefits.
- Saturday may be used as a make-up day for hours lost to inclement weather.
- When Bricklayers/Stone Masons work on Saturday with Laborers, and no other crafts are working on the project for the day, benefits may be paid at straight time. If other crafts are present, the applicable overtime rate for benefits shall be paid.

**NEW JERSEY DEPARTMENT OF LABOR AND WORKFORCE DEVELOPMENT
PREVAILING WAGE RATE DETERMINATION**

County - UNION

RECOGNIZED HOLIDAYS: New Year's Day, President's Day, Memorial Day, July 4th, Labor Day, Veterans' Day, Thanksgiving Day, Christmas Day. Sunday holidays will be observed the following Monday.

**NEW JERSEY DEPARTMENT OF LABOR AND WORKFORCE DEVELOPMENT
PREVAILING WAGE RATE DETERMINATION**

County - UNION

Craft: Carpenter PREVAILING WAGE RATE

	05/07/20
Foreman	W59.06 B34.29 T93.35
Journeyman	W51.36 B29.90 T81.26

Craft: Carpenter APPRENTICE RATE SCHEDULE

INTERVAL	PERIOD AND RATES									
Yearly	40%	55%	65%	80%	90%					
Benefit	57% of	Appren	tice	Wage	for all	intervals	+ \$0.63			

Ratio of Apprentices to Journeymen - 1:3

Craft: Carpenter COMMENTS/NOTES

FOREMAN REQUIREMENTS:

- When there are 2 or more Carpenters on a job, 1 shall be designated as a Foreman.
- When there are 21 or more Carpenters on a job, 2 shall be designated as Foremen.

The regular workday shall consist of 8 hours, starting between 6:00 AM and 9:00 AM.

SHIFT DIFFERENTIALS:

- When a 2 shift schedule (including a day shift) is established, the day shift shall be established on an 8 hour basis. The second shift shall be established on an 8 hour basis, and receive the regular rate plus 10%, inclusive of benefits.
- When a three shift schedule is established, the first shift shall be established on an 8 hour basis, the second shift on a 7.5 hour basis, and the third shift on a 7 hour basis. The first shift shall receive the regular hourly rate, the second shift shall receive the regular rate plus 10% and the third shift shall receive the regular rate plus 15%, inclusive of benefits.
- When there is no day shift, and a second or third shift is established, it shall be established on an 8 hour basis. The second shift shall receive the regular rate plus 10% and the third shift shall receive the regular rate plus 15%, inclusive of benefits.
- When an irregular shift must be established, this shift shall receive the regular rate plus 15%, inclusive of benefits.

OVERTIME:

- All hours in excess of 8 per day, or before or after an established shift that are not shift work, and all hours on Saturdays shall be paid at time and one-half the hourly rate, inclusive of benefits. All hours on Sundays and holidays shall be paid at double the hourly rate, inclusive of benefits.
- Four 10-hour days may be worked, Monday to Thursday, at straight time. Friday may be used as a make-up day for a day lost due to inclement weather. If Friday is not a make-up day, all hours on Friday shall be paid at time and one-half the hourly rate, inclusive of benefits.

RECOGNIZED HOLIDAYS: New Year's Day, Presidents' Day, Memorial Day, July 4th, Labor Day, Veterans' Day, Thanksgiving Day, Christmas Day. Sunday holidays observed the following Monday. Veterans' Day may be substituted for the day after Thanksgiving.

**NEW JERSEY DEPARTMENT OF LABOR AND WORKFORCE DEVELOPMENT
PREVAILING WAGE RATE DETERMINATION**

County - UNION

Craft: Carpenter - Resilient Flooring

PREVAILING WAGE RATE

	05/05/20
Foreman	W59.06 B34.20 T93.26
Journeyman	W51.36 B29.81 T81.17

Craft: Carpenter - Resilient Flooring

APPRENTICE RATE SCHEDULE

INTERVAL	PERIOD AND RATES									
Yearly	40%	55%	65%	80%	90%					
Benefit	57%	of	Appren	tice	Wage	for all	intervals	+ \$0.54		

Ratio of Apprentices to Journeymen - *

* 1 apprentice shall be allowed to every 2 journeymen or major fraction thereof. No more than 3 apprentices on any one job or project.

Craft: Carpenter - Resilient Flooring

COMMENTS/NOTES

FOREMAN REQUIREMENTS:

- On any job where there are 4 or more Carpenters of Resilient Flooring, 1 must be designated a Foreman.

FOR SYNTHETIC TURF INSTALLATION ONLY:

- The rate shall be 90% of the wage and benefit rate.

The regular workday consists of 8 hours, starting between 6:00 AM and 9:00 AM.

SHIFT DIFFERENTIALS:

- When a 2 shift schedule (including a day shift) is established, the day shift, shall be established on an 8 hour basis. The second shift shall be established on an 8 hour basis, and receive the regular wage rate plus 10%.
- When a three shift schedule is established, the first shift shall be established on an 8 hour basis, the second shift on a 7.5 hour basis, and the third shift on a 7 hour basis. The first shift shall receive the regular wage rate, the second shift shall receive the regular wage rate plus 10% and the third shift shall receive the regular wage rate plus 15%.
- When there is no day shift, and a second or third shift is established, it shall be established on an 8 hour basis. The second shift shall receive the regular wage rate plus 10% and the third shift shall receive the regular wage rate plus 15%.
- When an irregular shift must be established, this shift shall receive the regular rate plus 15%, inclusive of benefits.

OVERTIME:

- Hours in excess of 8 per day or 40 per week, or before or after the regular workday, Monday through Friday, shall be paid at time and one-half the wage rate. Saturday may be used as a make-up day, at straight time, up to 8 hours, for hours lost to reasons beyond the control of the employer, up to a total of 40 hours per week; hours in excess of 8 on Saturday shall then be paid at time and one-half the wage rate. If Saturday is not a make-up day, all hours on Saturday shall be paid at time and one-half the wage rate. All hours on Sundays and holidays shall be paid at double the wage rate.
- Four 10-hour days may be worked, Monday to Thursday, at straight time. Friday may be used as a make-up day for hours lost to reasons beyond the control of the employer. If Friday is not a make-up day, all hours on Friday shall be paid at time and one-half the wage rate.

**NEW JERSEY DEPARTMENT OF LABOR AND WORKFORCE DEVELOPMENT
PREVAILING WAGE RATE DETERMINATION**

County - UNION

RECOGNIZED HOLIDAYS: New Year's Day, Presidents' Day, Memorial Day, July 4th, Labor Day, Veterans' Day, Thanksgiving Day, Christmas Day. Sunday holidays will be observed the following Monday. Veterans' Day may be substituted for the day after Thanksgiving.

**NEW JERSEY DEPARTMENT OF LABOR AND WORKFORCE DEVELOPMENT
PREVAILING WAGE RATE DETERMINATION**

County - UNION

Craft: Commercial Painter- New Construction

PREVAILING WAGE RATE

	09/24/20
Foreman	W45.05 B27.06 T72.11
General Foreman	W49.14 B27.55 T76.69
Journeyman	W40.95 B26.56 T67.51

Craft: Commercial Painter- New Construction

APPRENTICE RATE SCHEDULE

INTERVAL	PERIOD AND RATES									
	40%	45%	55%	65%	70%	75%	80%	80%		
6 Months										
Benefits	8.05	8.05	10.05	10.05	11.05	11.05	14.05	14.05		

Ratio of Apprentices to Journeymen - 1:4

Craft: Commercial Painter- New Construction

COMMENTS/NOTES

* Commercial Painters perform work on all commercial structures such as offices, schools, hotels, shopping malls, restaurants, condominiums, etc.

Spraying, sandblasting, lead abatement work on commercial buildings, work performed above 3 stories or 30 feet in height, or using swing scaffolds requires an additional 10% of the wage rate.

FOREMEN REQUIREMENTS:

- When there are 4 or more Painters on a job, 1 shall be designated a Foreman.
- When there are 15 or more Painters on a job, 1 shall be designated a General Foreman.

The regular workday shall consist of 8 hours between 7:00 AM and 5:30 PM.

SHIFT DIFFERENTIALS:

- The second shift shall receive an additional 10% of the hourly rate, per hour, and the third shift shall receive an additional 15% of the hourly rate, per hour.

OVERTIME:

- Hours in excess of 8 per day, or before or after the regular workday, Monday through Friday, and all hours on Saturdays shall be paid at time and one-half the regular rate. All hours on Sundays and holidays shall be paid at double the regular rate.
- Saturday or Sunday may be used to make up a day lost to inclement weather, at straight time.
- Four 10-hour days may be worked, at straight time, Monday through Friday.

RECOGNIZED HOLIDAYS: New Year's Day, President's Day, Memorial Day, July 4th, Labor Day, General Election Day,

**NEW JERSEY DEPARTMENT OF LABOR AND WORKFORCE DEVELOPMENT
PREVAILING WAGE RATE DETERMINATION**

County - UNION

Veterans' Day, Thanksgiving Day, Christmas Day.

**NEW JERSEY DEPARTMENT OF LABOR AND WORKFORCE DEVELOPMENT
PREVAILING WAGE RATE DETERMINATION**

County - UNION

Craft: Commercial Painter- Repainting

PREVAILING WAGE RATE

	09/24/20
Foreman	W33.11 B20.66 T53.77
General Foreman	W34.61 B20.66 T55.27
Journeyman	W30.10 B20.66 T50.76

Craft: Commercial Painter- Repainting

APPRENTICE RATE SCHEDULE

INTERVAL	PERIOD AND RATES									
	SEE	COMME	CIAL	PAINTER	NEW	CONSTR	TION			
		R				UC				

Ratio of Apprentices to Journeymen - 1:4

Craft: Commercial Painter- Repainting

COMMENTS/NOTES

* Commercial Painters perform work on all commercial structures such as offices, schools, hotels, shopping malls, restaurants, condominiums, etc.

NOTE: These rates may only be used on jobs where no major alterations (only doing painting and carpeting with nothing else being changed in the commercial building) occur, and where not more than 3 other trades are present on the job, but may NOT, under any circumstances, be used for work on bridges, stacks, tanks, or generating stations.

Spraying, sandblasting, lead abatement work on commercial buildings, work performed above 3 stories or 30 feet in height, or using swing scaffolds requires an additional 10% of the wage rate.

FOREMEN REQUIREMENTS:

- When there are 4 or more Painters on a job, 1 shall be designated a Foreman.
- When there are 15 or more Painters on a job, 1 shall be designated a General Foreman.

OVERTIME:

- Hours in excess of 8 per day and 40 per week shall be paid at time and one-half the regular rate. All hours on Sundays and holidays shall be paid at double the regular rate.
- Four 10-hour days may be worked, at straight time, Monday through Sunday.

RECOGNIZED HOLIDAYS: New Year's Day, President's Day, Memorial Day, July 4th, Labor Day, General Election Day, Veterans' Day, Thanksgiving Day, Christmas Day.

**NEW JERSEY DEPARTMENT OF LABOR AND WORKFORCE DEVELOPMENT
PREVAILING WAGE RATE DETERMINATION**

County - UNION

Craft: Diver PREVAILING WAGE RATE

	05/05/20
Diver	W60.24 B48.47 T108.71
Tender	W48.50 B48.47 T96.97

Craft: Diver COMMENTS/NOTES

NOTE: All dive crews must consist of a Tender, a Diver, and a standby Diver (standby Diver is the same rate as a Diver).

DEPTH & PENETRATION RATES: Divers shall be paid the following depth and penetration rates, in addition to the regular hourly rate, when applicable:

AIR DIVES:

- 0-59 feet: No additional wage
- 60-74 feet: + \$0.25 per foot
- 75-125 feet: + \$0.78 per foot

MIXED GAS DIVES:

- 0-74 feet: No additional wage
- 75-125 feet: + \$1.00 per foot
- 126-200 feet: + \$2.00 per foot

PENETRATION DIVES:

- 126-200 feet: + \$1.50 per foot
- 201-275 feet: + \$1.75 per foot
- 276-350 feet: + \$2.00 per foot
- 351-425 feet: + \$2.50 per foot

OVERTIME:

Hours in excess of 8 per day, Monday through Friday, and all hours on Saturdays shall be paid at time and one-half the hourly rate. All hours on Sundays and holidays shall be paid at double the hourly rate.

RECOGNIZED HOLIDAYS: New Year's Day, Presidents' Day, Memorial Day, July 4th, Labor Day, Veterans' Day, Presidential Election Day, Thanksgiving Day, Christmas Day. Veterans' Day may be switched with the day after Thanksgiving.

**NEW JERSEY DEPARTMENT OF LABOR AND WORKFORCE DEVELOPMENT
PREVAILING WAGE RATE DETERMINATION**

County - UNION

Craft: Dockbuilder PREVAILING WAGE RATE

	05/05/20
Foreman	W55.78 B48.47 T104.25
Foreman (Concrete Form Work)	W54.97 B35.36 T90.33
Journeyman	W48.50 B48.47 T96.97
Journeyman (Concrete Form Work)	W47.80 B35.36 T83.16

Craft: Dockbuilder APPRENTICE RATE SCHEDULE

<u>INTERVAL</u>	<u>PERIOD AND RATES</u>									
Yearly	19.40	24.25	31.53	38.80						
Benefit	32.07	for all	intervals							

Ratio of Apprentices to Journeymen - *

* When there are 4 or fewer Dockbuilders on a job, no more than 1 may be an apprentice. When there are 5 or more Dockbuilders, there may be 1 apprentice for every 5 Dockbuilders.

Craft: Dockbuilder COMMENTS/NOTES

APPRENTICE RATE SCHEDULE FOR CONCRETE FORM WORK ONLY:

INTERVAL	PERIOD AND RATES			
Yearly	19.12	23.90	31.07	38.24
Benefits	24.16	for all	intervals	

CREOSOTE HANDLING:

When handling creosote products on land piledriving, floating marine construction, and construction of wharves, the worker shall receive an additional \$0.25 per hour.

HAZARDOUS WASTE WORK:

- Hazardous waste removal work on a state or federally designated hazardous waste site where Level A, B, or C personal protection is required: an additional 20% of the hourly rate, per hour.
- Hazardous waste removal work in Level D, or where personal protection is not required: an additional \$1.00 per hour.

CERTIFIED WELDER: When required on the job by the project owner, a Certified Welder shall receive an additional \$1.00 per hour.

FOREMAN REQUIREMENTS:

The first Dockbuilder on the job shall be designated a Foreman.

**NEW JERSEY DEPARTMENT OF LABOR AND WORKFORCE DEVELOPMENT
PREVAILING WAGE RATE DETERMINATION**

County - UNION

OVERTIME:

Hours in excess of 8 per day, Monday through Friday, and all hours on Saturdays shall be paid at time and one-half the hourly rate. All hours on Sundays and holidays shall be paid at double the hourly rate.

RECOGNIZED HOLIDAYS: New Year's Day, Presidents' Day, Memorial Day, July 4th, Labor Day, Veterans' Day, Presidential Election Day, Thanksgiving Day, Christmas Day. Veterans' Day may be switched with the day after Thanksgiving.

**NEW JERSEY DEPARTMENT OF LABOR AND WORKFORCE DEVELOPMENT
PREVAILING WAGE RATE DETERMINATION**

County - UNION

Craft: Drywall Finisher

PREVAILING WAGE RATE

	09/24/20
Foreman	W44.43 B27.06 T71.49
General Foreman	W46.45 B27.06 T73.51
Journeyman	W40.39 B27.06 T67.45

Craft: Drywall Finisher

APPRENTICE RATE SCHEDULE

INTERVAL	PERIOD AND RATES									
	40%	50%		60%	70%		80%	90%		
6 Months										
Benefits	Intervals	1 to 2 =	10.65	Intervals	3 to 4 =	13.41	Intervals	5 to 6 =	16.63	

Ratio of Apprentices to Journeymen - 1:4

Craft: Drywall Finisher

COMMENTS/NOTES

The regular workday shall consist of 8 hours between 7:00 AM and 5:30 PM.

SHIFT DIFFERENTIALS:

- The second shift shall receive an additional 10% of the hourly rate, per hour, and the third shift shall receive an additional 15% of the hourly rate, per hour.
- When 3 shifts are worked, the second shift shall receive 8 hours pay for 7.5 hours of work, and the third shift shall receive 8 hours pay for 7 hours of work.
- Shift work must run for a minimum of 5 consecutive workdays.

OVERTIME:

- Hours in excess of 8 per day, Monday through Friday, and all hours on Saturdays shall be paid at time and one-half the regular rate, inclusive of benefits. All hours on Sundays and holidays shall be paid at double the regular rate, inclusive of benefits.
- Saturday or Sunday may be used to make up a day lost to inclement weather, at straight time.

RECOGNIZED HOLIDAYS: New Year's Day, Memorial Day, July 4th, Labor Day, Presidential Election Day, Veterans' Day, Thanksgiving Day, Christmas Day. Saturday holiday observed the preceding Friday. Sunday holiday observed the following Monday.

**NEW JERSEY DEPARTMENT OF LABOR AND WORKFORCE DEVELOPMENT
PREVAILING WAGE RATE DETERMINATION**

County - UNION

Craft: Electrician

PREVAILING WAGE RATE

	06/01/20	05/31/21
Cable Splicer	W63.83 B37.99 T101.82	W64.92 B39.29 T104.21
Foreman (11-20 Journeymen)	W67.90 B40.41 T108.31	W69.05 B41.78 T110.83
Foreman (1-3 Journeymen)	W63.83 B37.99 T101.82	W64.92 B39.29 T104.21
Foreman (4-10 Journeymen)	W66.74 B39.72 T106.46	W67.87 B41.07 T108.94
General Foreman (21-30 Journeymen)	W69.64 B41.44 T111.08	W70.82 B42.85 T113.67
General Foreman (31-60 Journeymen)	W75.44 B44.89 T120.33	W76.72 B46.42 T123.14
General Foreman (61+ Journeymen)	W76.60 B45.58 T122.18	W77.90 B47.13 T125.03
Journeyman	W58.03 B34.54 T92.57	W59.02 B35.72 T94.74
Sub-Foreman	W66.16 B39.37 T105.53	W67.28 B40.71 T107.99

Craft: Electrician

APPRENTICE RATE SCHEDULE

<u>INTERVAL</u>	<u>PERIOD AND RATES</u>									
Yearly	40%	49%	58%	68%	80%		of Jour	neyman	Wage	Rate
Benefit	40%	49%	58%	68%	80%		of Jour	neyman	Benefit	Rate

Ratio of Apprentices to Journeymen - 2:3

Craft: Electrician

COMMENTS/NOTES

**NEW JERSEY DEPARTMENT OF LABOR AND WORKFORCE DEVELOPMENT
PREVAILING WAGE RATE DETERMINATION**

County - UNION

THESE RATES ALSO APPLY TO THE FOLLOWING:

- All burglar and fire alarm work.
- All fiber optic work.
- Teledata work in new construction.
- Teledata work involving 16 Voice/Data Lines or more.

The regular workday shall be 8 hours, between 8:00 AM and 4:30 PM.

FOREMAN REQUIREMENTS:

- 1 to 3 Journeymen- 1 must be a Foreman (Foreman/1-3 Journeymen rate).
- 4 to 10 Journeymen- 1 must be a Foreman (Foreman/4-10 Journeymen rate).
- 11 to 20 Journeymen- 1 must be Foreman (Foreman/11-20 Journeymen rate) and 1 must be a Sub-Foreman.
- 21 to 30 Journeymen- 1 must be a General Foreman (General Foreman/21-30 Journeymen rate) and 2 must be a Sub-Foreman.
- 31 to 40 Journeymen- 1 must be a General Foreman (General Foreman/31-40 Journeymen rate) and 3 must be a Sub-Foreman.
- 41 to 50 Journeymen- 1 must be a General Foreman (General Foreman/31-60 Journeymen rate) and 4 must be a Sub-Foreman.
- 51 to 60 Journeymen- 1 must be a General Foreman (General Foreman/31-60 Journeymen rate) and 5 must be a Sub-Foreman.
- 61+ Journeymen- 1 must be a General Foreman (General Foreman/61+ Journeymen rate) and 6 must be a Sub-Foreman.

SHIFT DIFFERENTIALS:

- Shift work must run for a minimum of 5 consecutive workdays.
- 2nd Shift (4:30 PM to 12:30 AM) shall receive 8 hours pay for 7.5 hours work + an additional 10% of the regular rate, per hour, inclusive of benefits.
- 3rd Shift (12:30 AM to 8:00 AM) shall receive 8 hours pay for 7 hours work + an additional 15% of the regular rate, per hour, inclusive of benefits.

OVERTIME:

Hours in excess of 8 per day, or outside of the regular workday, Monday through Friday, and all hours on Saturdays, shall be paid at time and one-half the regular rate, inclusive of benefits. All hours on Sundays and holidays shall be paid at double the regular rate, inclusive of benefits.

RECOGNIZED HOLIDAYS: New Year's Day, Presidents' Day, Memorial Day, July 4th, Labor Day, Presidential Election Day, Veterans' Day, Thanksgiving Day, Christmas Day.

**NEW JERSEY DEPARTMENT OF LABOR AND WORKFORCE DEVELOPMENT
PREVAILING WAGE RATE DETERMINATION**

County - UNION

Craft: Electrician - Teledata (15 Voice/Data Lines & Less)

PREVAILING WAGE RATE

	10/28/19	11/02/20
Master	W56.16	W57.42
Technician/General	B30.89	B31.58
Foreman	T87.05	T89.00
Senior Technician/Lead Foreman (21-30 Workers on Job)	W51.41 B28.27 T79.68	W52.56 B28.91 T81.47
Technician A/Foreman (11-20 Workers on Job)	W49.25 B27.08 T76.33	W50.35 B27.69 T78.04
Technician B/Working Foreman (4-10 Workers on Job)	W47.09 B25.90 T72.99	W48.15 B26.47 T74.62
Technician C/Journeyman (1-3 Workers on Job)	W43.20 B23.76 T66.96	W44.17 B24.29 T68.46

Craft: Electrician - Teledata (15 Voice/Data Lines & Less)

APPRENTICE RATE SCHEDULE

<u>INTERVAL</u>	<u>PERIOD AND RATES</u>										
6 Months						66%	72%	79%	86%		
Benefits						11.81	12.89	14.14	15.40		

Ratio of Apprentices to Journeymen - 2:3

Craft: Electrician - Teledata (15 Voice/Data Lines & Less)

COMMENTS/NOTES

APPRENTICE RATE SCHEDULE FOR THOSE APPRENTICES ENTERING PROGRAM AFTER 10-31-14:

INTERVAL	PERIOD AND RATES										
6 Months	35%	35%	40%	43%	48%	54%	61%	67%	74%	81%	
Benefits	6.76	6.76	7.16	7.70	8.59	9.66	10.82	11.99	13.25	14.51	

NOTES:

- These rates are for service, maintenance, moves, and/or changes affecting 15 Voice/Data (teledata) lines or less. These rates may NOT be used for any teledata work in new construction (including additions) or any fiber optic work.
- The number of Teledata workers on the jobsite is the determining factor for which Foreman category applies .

The regular workday shall be 8 hours, between 8:00 AM and 4:30 PM.

SHIFT DIFFERENTIALS:

- Shift work must run for a minimum of 5 consecutive workdays.

**NEW JERSEY DEPARTMENT OF LABOR AND WORKFORCE DEVELOPMENT
PREVAILING WAGE RATE DETERMINATION**

County - UNION

- 2nd Shift (4:30 PM to 12:30 AM) shall receive 8 hours pay for 7.5 hours work + an additional 10% of the regular rate, per hour, inclusive of benefits.
- 3rd Shift (12:30 AM to 8:00 AM) shall receive 8 hours pay for 7 hours work + an additional 15% of the regular rate, per hour, inclusive of benefits.

OVERTIME:

Hours in excess of 8 per day, or outside of the regular workday, Monday through Friday, and all hours on Saturdays, shall be paid at time and one-half the regular rate, inclusive of benefits. All hours on Sundays and holidays shall be paid at double the regular rate, inclusive of benefits.

RECOGNIZED HOLIDAYS: New Year's Day, Presidents' Day, Memorial Day, July 4th, Labor Day, Presidential Election Day, Veterans' Day, Thanksgiving Day, Christmas Day.

**NEW JERSEY DEPARTMENT OF LABOR AND WORKFORCE DEVELOPMENT
PREVAILING WAGE RATE DETERMINATION**

County - UNION

Craft: Electrician - Teledata (16 Instruments & More)

PREVAILING WAGE RATE

See "Electrician" Rates

Craft: Electrician - Teledata (16 Instruments & More)

COMMENTS/NOTES

See ELECTRICIAN Rates

**NEW JERSEY DEPARTMENT OF LABOR AND WORKFORCE DEVELOPMENT
PREVAILING WAGE RATE DETERMINATION**

County - UNION

Craft: Electrician- Outside Commercial

PREVAILING WAGE RATE

	06/01/20	05/31/21
Cable Splicer	W64.14 B37.69 T101.83	W65.22 B38.97 T104.19
Certified Welder	W61.22 B35.97 T97.19	W62.26 B37.21 T99.47
Equipment Operator	W58.31 B34.26 T92.57	W59.29 B35.43 T94.72
Foreman (1-3 Journeymen workers on job)	W64.14 B37.69 T101.83	W65.22 B38.97 T104.19
Foreman (4-10 Journeymen workers on job)	W67.06 B39.40 T106.46	W68.19 B40.75 T108.94
General Foreman (11-20 Journeymen workers on job)	W68.22 B40.08 T108.30	W69.37 B41.45 T110.82
General Foreman (21-30 Journeymen workers on job)	W69.97 B41.11 T111.08	W71.16 B42.52 T113.68
General Foreman (31-60 Journeymen workers on job)	W75.80 B44.54 T120.34	W77.08 B46.06 T123.14
General Foreman (61+ Journeymen workers on job)	W76.96 B45.22 T122.18	W78.27 B46.77 T125.04
Groundman	W34.99 B20.56 T55.55	W35.58 B21.26 T56.84
Journeyman Lineman/Technician	W58.31 B34.26 T92.57	W59.29 B35.43 T94.72
Sub-Foreman	W66.47 B39.06 T105.53	W67.60 B40.40 T108.00

**NEW JERSEY DEPARTMENT OF LABOR AND WORKFORCE DEVELOPMENT
PREVAILING WAGE RATE DETERMINATION**

County - UNION

Craft: Electrician- Outside Commercial

APPRENTICE RATE SCHEDULE

INTERVAL	PERIOD AND RATES									
1000 Hours	60%	65%	70%	75%	80%	85%	90%			
Benefits	57.75% of	Journey	man	wage	+	\$.01				

Craft: Electrician- Outside Commercial

COMMENTS/NOTES

EFFECTIVE 6-1-20- The apprentice benefit rate shall be 58.75% + \$.01.
EFFECTIVE 5-31-21- The apprentice benefit rate shall be 59.75% + \$.01.

* FOR UTILITY WORK PLEASE SEE STATEWIDE RATES

The regular worday shall be 8 hours, between 8:00 AM and 4:30 PM.

FOREMAN REQUIREMENTS:

- 1 to 3 Journeymen- 1 must be a Foreman (Foreman/1-3 Journeymen rate).
- 4 to 10 Journeymen- 1 must be a Foreman (Foreman/4-10 Journeymen rate).
- 11 to 20 Journeymen- 1 must be Foreman (Foreman/11-20 Journeymen rate) and 1 must be a Sub-Foreman.
- 21 to 30 Journeymen- 1 must be a General Foreman (General Foreman/21-30 Journeymen rate) and 2 must be a Sub-Foreman.
- 31 to 40 Journeymen- 1 must be a General Foreman (General Foreman/31-40 Journeymen rate) and 3 must be a Sub-Foreman.
- 41 to 50 Journeymen- 1 must be a General Foreman (General Foreman/31-60 Journeymen rate) and 4 must be a Sub-Foreman.
- 51 to 60 Journeymen- 1 must be a General Foreman (General Foreman/31-60 Journeymen rate) and 5 must be a Sub-Foreman.
- 61+ Journeymen- 1 must be a General Foreman (General Foreman/61+ Journeymen rate) and 6 must be a Sub-Foreman.

SHIFT DIFFERENTIALS:

- Shift work must run for a minimum of 5 consecutive workdays.
- 2nd Shift (4:30 PM to 12:30 AM): 8 hrs. pay for 7.5 hrs. work + an additional 10% of the regular rate, inclusive of benefits.
- 3rd Shift (12:30 AM to 8:00 AM): 8 hrs. pay for 7 hrs. work + an additional 15% of the regular rate per hour, inclusive benefits.

OVERTIME:

Hours in excess of 8 per day, or outside of the regular workday, Monday through Friday, and all hours on Saturdays, shall be paid at time and one-half the regular rate, inclusive of benefits. All hours on Sundays and holidays shall be paid at double the regular rate, inclusive of benefits.

RECOGNIZED HOLIDAYS:

New Year's Day, Presidents' Day, Memorial Day, July 4th, Labor Day, Presidential Election Day, Veterans' Day, Thanksgiving Day and Christmas Day.

**NEW JERSEY DEPARTMENT OF LABOR AND WORKFORCE DEVELOPMENT
PREVAILING WAGE RATE DETERMINATION**

County - UNION

Craft: Electrician-Utility Work (North)

PREVAILING WAGE RATE

Rates are located in the "Statewide" rate package

Craft: Electrician-Utility Work (North)

APPRENTICE RATE SCHEDULE

INTERVAL	PERIOD AND RATES									
* 6 Months	60%	65%	70%	75%	80%	85%	90%			
Benefits	69% of	Appren	tice	Wage	Rate	for all	intervals			

Craft: Electrician-Utility Work (North)

COMMENTS/NOTES

Electrician-Utility Work (North) rates are located in the "Statewide" rate package.

* The apprentice wage rate is paid at the percentage of the Journeyman Lineman wage rate located in the "Statewide" rate package.

**NEW JERSEY DEPARTMENT OF LABOR AND WORKFORCE DEVELOPMENT
PREVAILING WAGE RATE DETERMINATION**

County - UNION

Craft: Electrician-Utility Work (South)

PREVAILING WAGE RATE

Rates are located in the "Statewide" rate package

Craft: Electrician-Utility Work (South)

APPRENTICE RATE SCHEDULE

INTERVAL	PERIOD AND RATES									
6 Months	29.11	31.54	33.96	36.39	38.82	41.24	43.67			
Benefits	25.61	27.04	28.46	29.90	31.33	32.79	34.23			

Craft: Electrician-Utility Work (South)

COMMENTS/NOTES

Electrician-Utility Work (South) rates are located in the "Statewide" rate package.

**NEW JERSEY DEPARTMENT OF LABOR AND WORKFORCE DEVELOPMENT
PREVAILING WAGE RATE DETERMINATION**

County - UNION

Craft: Elevator Constructor **PREVAILING WAGE RATE**

	03/17/20	03/17/21	03/17/22	03/17/23
Journeyman	W69.56	W72.29	W75.14	W77.49
	B41.92	B42.92	B43.91	B45.57
	T111.48	T115.21	T119.05	T123.06

Craft: Elevator Constructor **APPRENTICE RATE SCHEDULE**

INTERVAL	PERIOD AND RATES									
	Yearly	29.85	36.82	43.52	50.21					
Benefits	32.71	33.51	34.80	36.09						

Ratio of Apprentices to Journeymen - 1:1

Craft: Elevator Constructor **COMMENTS/NOTES**

APPRENTICE RATE SCHEDULE AS OF 3-17-20:

INTERVAL	PERIOD AND RATES			
Yearly	31.03	38.26	45.21	52.17
Benefits	33.38	34.20	35.55	36.89

APPRENTICE RATE SCHEDULE AS OF 3-17-21:

INTERVAL	PERIOD AND RATES			
Yearly	32.27	39.76	46.99	54.22
Benefits	34.05	34.91	36.30	37.70

APPRENTICE RATE SCHEDULE AS OF 3-17-22:

INTERVAL	PERIOD AND RATES			
Yearly	33.56	41.33	48.84	56.36
Benefits	34.72	35.61	37.05	38.50

APPRENTICE RATE SCHEDULE AS OF 3-17-23:

INTERVAL	PERIOD AND RATES			
Yearly	34.60	42.62	50.37	58.12
Benefits	36.02	36.94	38.50	39.95

The regular workday shall consist of either 7 or 8 hours to be established at the beginning of the project, between 7:00 AM and 4:30 PM.

OVERTIME:

For all hours worked before or after the regular workday, Monday through Friday, and all hours on Saturday and Sunday, shall be paid at double the hourly rate. Holiday pay is one days wages (8 hours) plus double the hourly rate for all hours worked.

RECOGNIZED HOLIDAYS: New Year's Day, Presidents' Day, Good Friday, Memorial Day, July 4th, Labor Day, Columbus

**NEW JERSEY DEPARTMENT OF LABOR AND WORKFORCE DEVELOPMENT
PREVAILING WAGE RATE DETERMINATION**

County - UNION

Day, Veterans' Day, Thanksgiving Day and the day after, Christmas Day. Saturday holidays shall be observed on the previous Friday and Sunday holidays shall be observed on the following Monday.

**NEW JERSEY DEPARTMENT OF LABOR AND WORKFORCE DEVELOPMENT
PREVAILING WAGE RATE DETERMINATION**

County - UNION

Craft: Elevator Modernization & Service

PREVAILING WAGE RATE

	03/17/20	03/17/21	03/17/22	03/17/23
Journeyman	W54.56	W56.77	W59.09	W60.89
	B40.86	B41.82	B42.79	B44.41
	T95.42	T98.59	T101.88	T105.30

Craft: Elevator Modernization & Service

APPRENTICE RATE SCHEDULE

INTERVAL	PERIOD AND RATES									
Yearly	29.85	28.84	34.09	39.33						
Benefits	32.66	33.13	34.36	35.58						

Ratio of Apprentices to Journeymen - 1:1

Craft: Elevator Modernization & Service

COMMENTS/NOTES

APPRENTICE RATE SCHEDULE AS OF 3-17-20:

INTERVAL	PERIOD AND RATES			
Yearly	31.03	30.01	35.46	40.92
Benefits	33.33	33.82	35.09	36.36

APPRENTICE RATE SCHEDULE AS OF 3-17-21:

INTERVAL	PERIOD AND RATES			
Yearly	32.27	31.22	36.90	42.58
Benefits	34.00	34.50	35.83	37.15

APPRENTICE RATE SCHEDULE AS OF 3-17-22:

INTERVAL	PERIOD AND RATES			
Yearly	33.56	32.50	38.41	44.32
Benefits	34.67	34.20	35.20	37.94

APPRENTICE RATE SCHEDULE AS OF 3-17-23:

INTERVAL	PERIOD AND RATES			
Yearly	34.60	33.49	39.58	45.67
Benefits	35.97	36.53	37.95	39.38

MODERNIZATION (addition, replacement, refurbishing, relocation, or changes in design or appearance, of elevator equipment in existing buildings):

- The regular workday consists of 8 hours, between 7:00 AM and 4:30 PM.

- Overtime:

Hours in excess of 8 per day, or before or after the regular workday, Monday through Friday, and all hours on Saturday and Sunday shall be paid at time and one-half the hourly rate. Holiday pay is one days wages (8 hours) plus time and one-half the hourly rate for all hours worked.

**NEW JERSEY DEPARTMENT OF LABOR AND WORKFORCE DEVELOPMENT
PREVAILING WAGE RATE DETERMINATION**

County - UNION

SERVICE (repair or replacement of parts for the purpose of maintaining elevator equipment in good operating condition):

- The regular workday consists of 8 hours, between 6:00 AM and 6:00 PM.

- Overtime:

Hours in excess of 8 per day, or before or after the regular workday, Monday through Friday, and all hours on Saturday shall be paid at time and one-half the hourly rate. All hours on Sunday and holidays shall be paid at double the hourly rate.

RECOGNIZED HOLIDAYS (Modernization and Service): New Year's Day, Presidents' Day, Good Friday, Memorial Day, July 4th, Labor Day, Columbus Day, Veterans' Day, Thanksgiving Day and the day after, Christmas Day. Saturday holidays shall be observed on the previous Friday and Sunday holidays shall be observed on the following Monday.

**NEW JERSEY DEPARTMENT OF LABOR AND WORKFORCE DEVELOPMENT
PREVAILING WAGE RATE DETERMINATION**

County - UNION

Craft: Glazier PREVAILING WAGE RATE

	09/24/20
* Leadman	W48.80 B27.31 T76.11
Foreman	W50.80 B27.55 T78.35
General Foreman	W52.80 B27.79 T80.59
Journeyman	W46.80 B27.07 T73.87

Craft: Glazier APPRENTICE RATE SCHEDULE

<u>INTERVAL</u>	<u>PERIOD AND RATES</u>									
6 Months	50%	55%		60%	65%		70%	75%		
Benefits	Intervals	1 to 2 =	9.50	Intervals	3 to 4 =	12.11	Intervals	5 to 6 =	15.60	

Ratio of Apprentices to Journeymen - 1:4

Craft: Glazier COMMENTS/NOTES

Hazard/Height Pay: +\$1.00 per hour

* When there are three (3) men working on a jobsite for three (3) days or longer, 1 Journeyman may be designated as a Leadman for the duration of the job, provided he has his OSHA certification.

FOREMAN REQUIREMENTS:

- When there are 4 or more Glaziers on a job, 1 must be designated a Foreman.
- When there are 15 or more Glaziers on a job, 1 must be designated a General Foreman.

The regular workday shall consist of 8 hours, between 7:00 AM and 5:30 PM, Monday to Friday.

SHIFT DIFFERENTIALS:

- The second shift shall receive an additional 10% of the hourly rate, per hour, and the third shift shall receive an additional 15% of the hourly rate, per hour.
- When 3 shifts are worked, the second shift shall receive 8 hours pay for 7.5 hours of work, and the third shift shall receive 8 hours pay for 7 hours of work.

OVERTIME:

Hours in excess of 8 per day, or before or after the regular workday Monday through Friday, and all hours on Saturdays shall be paid at time and one-half the regular rate. All hours on Sundays and holidays shall be paid at double the regular

**NEW JERSEY DEPARTMENT OF LABOR AND WORKFORCE DEVELOPMENT
PREVAILING WAGE RATE DETERMINATION**

County - UNION

rate.

RECOGNIZED HOLIDAYS: New Year's Day, Memorial Day, July 4th, Labor Day, General Election Day, Veterans' Day, Thanksgiving Day, Christmas Day. Saturday holiday observed the preceding Friday. Sunday holiday observed the following Monday.

**NEW JERSEY DEPARTMENT OF LABOR AND WORKFORCE DEVELOPMENT
PREVAILING WAGE RATE DETERMINATION**

County - UNION

Craft: Heat & Frost Insulator

PREVAILING WAGE RATE

	09/21/20
Foreman	W58.52 B33.42 T91.94
General Foreman	W60.86 B34.53 T95.39
Journeyman	W56.74 B32.86 T89.60

Craft: Heat & Frost Insulator

APPRENTICE RATE SCHEDULE

INTERVAL	PERIOD AND RATES									
Yearly	26.55	31.49	37.95	44.36						
Benefits	19.44	23.03	25.44	27.76						

Ratio of Apprentices to Journeymen - 1:3

Craft: Heat & Frost Insulator

COMMENTS/NOTES

NOTE: These rates apply to the installing of insulation on hot and cold mechanical systems.

The regular workday shall be 8 hours between 7:00 AM and 3:30 PM. In addition, the regular workday may also be 8 hours between 6:00 AM and 2:30 PM.

SHIFT DIFFERENTIAL:

- Shift work must run for a minimum of 5 consecutive workdays.
- Second Shift shall work 7.5 hours and receive 8 hours pay, at the regular rate, plus 25% per hour.
- Third Shift shall work 7 hours and receive 8 hours pay, at the regular rate, plus 30% per hour.

OVERTIME:

The first 2 hours in excess of 8 per day, hours outside of the regular workday Monday through Friday that are not shift work, and the first 10 hours on Saturday, shall be paid at time and one-half the regular rate, inclusive of benefits. All hours in excess of 10 per day, and all hours on Sunday and holidays (except Labor Day) shall be paid at double the regular rate, inclusive of benefits. All hours on Labor Day shall be paid at triple the regular rate, inclusive of benefits.

RECOGNIZED HOLIDAYS: New Year's Day, President's Day, Memorial Day, July 4th, Labor Day, Veterans' Day, Presidential Election Day, Thanksgiving Day and Christmas Day. Sunday holidays observed the following Monday.

**NEW JERSEY DEPARTMENT OF LABOR AND WORKFORCE DEVELOPMENT
PREVAILING WAGE RATE DETERMINATION**

County - UNION

Craft: Heat & Frost Insulator - Asbestos Worker

PREVAILING WAGE RATE

	09/24/19
Asbestos Helper	W36.89
Abatement	B24.92
	T61.81

Craft: Heat & Frost Insulator - Asbestos Worker

APPRENTICE RATE SCHEDULE

INTERVAL	PERIOD AND RATES									
	SEE	HEAT &	FROST	INSULAT OR						

Ratio of Apprentices to Journeymen - 1:3

Craft: Heat & Frost Insulator - Asbestos Worker

COMMENTS/NOTES

NOTE: These rates apply only to the removal of insulation materials/asbestos from mechanical systems, including containment erection and demolition, and placing material in appropriate containers.

The regular workday shall be 8 hours between 7:00 AM and 3:30 PM. In addition, the regular workday may also be 8 hours between 6:00 AM and 2:30 PM.

SHIFT DIFFERENTIALS:

- Shift work must run for a minimum of 5 consecutive workdays.
- The second shift shall work 7.5 hours and receive 8 hours pay at the regular rate, plus 25% per hour.
- The third shift shall work 7 hours and receive 8 hours pay at the regular rate, plus 30% per hour.

OVERTIME: The first 2 hours in excess of 8 per day, hours outside of the regular workday Monday through Friday that are not shift work, and the first 10 hours on Saturday, shall be paid at time and one-half the regular rate, inclusive of benefits. All hours in excess of 10 per day, and all hours on Sunday and holidays (except Labor Day) shall be paid at double the regular rate, inclusive of benefits. All hours on Labor Day shall be paid at triple the regular rate, inclusive of benefits.

RECOGNIZED HOLIDAYS: New Year's Day, Presidents' Day, Memorial Day, July 4th, Labor Day, Veterans' Day, Presidential Election Day, Thanksgiving Day and Christmas Day. Sunday holidays observed the following Monday.

**NEW JERSEY DEPARTMENT OF LABOR AND WORKFORCE DEVELOPMENT
PREVAILING WAGE RATE DETERMINATION**

County - UNION

Craft: Industrial Painter- Bridges

PREVAILING WAGE RATE

	07/28/20
Foreman	W62.18 B28.99 T91.17
General Foreman	W64.18 B28.99 T93.17
Journeyman	W57.18 B28.99 T86.17

Craft: Industrial Painter- Bridges

APPRENTICE RATE SCHEDULE

INTERVAL	PERIOD AND RATES									
	40%	50%			60%	70%		80%	90%	
6 Months										
Benefits	Intervals	1 to 2 =	10.28	Intervals	3 to 4 =	12.55	Intervals	5 to 6 =	15.56	

Ratio of Apprentices to Journeymen - 1:4

Craft: Industrial Painter- Bridges

COMMENTS/NOTES

* Industrial Painters perform work on all industrial structures, such as bridges, water tanks, waste water facilities, refineries, any structural steel work, etc.

These rates apply to: All bridges that span waterways, roadways, railways and canyons. All tunnels, overpasses, viaducts and all appurtenances.

FOREMEN REQUIREMENTS:

- When there are 4 or more Painters on a job, 1 shall be designated a Foreman.
- When there are 15 or more Painters on a job, 1 shall be designated a General Foreman.

The regular workday shall consist of 8 hours between 7:00 AM and 5:30 PM.

SHIFT DIFFERENTIALS:

- The second shift shall receive an additional 10% of the hourly rate, per hour, and the third shift shall receive an additional 15% of the hourly rate, per hour.

OVERTIME:

- Hours in excess of 8 per day, Monday through Friday, and all hours on Saturdays and Sundays shall be paid at time and one-half the regular rate. All hours on holidays shall be paid at double the regular rate.
- Saturday or Sunday may be used to make up a day lost to inclement weather, at straight time.
- Four 10-hour days may be worked, at straight time, Monday through Friday.

RECOGNIZED HOLIDAYS: New Year's Day, President's Day, Memorial Day, July 4th, Labor Day, Presidential Election Day, Veterans' Day, Thanksgiving Day, Christmas Day. Saturday holiday observed the preceding Friday. Sunday holiday

**NEW JERSEY DEPARTMENT OF LABOR AND WORKFORCE DEVELOPMENT
PREVAILING WAGE RATE DETERMINATION**

County - UNION

observed the following Monday.

**NEW JERSEY DEPARTMENT OF LABOR AND WORKFORCE DEVELOPMENT
PREVAILING WAGE RATE DETERMINATION**

County - UNION

Craft: Industrial Painter- Structural Steel

PREVAILING WAGE RATE

	07/28/20
Foreman	W50.92 B26.64 T77.56
General Foreman	W52.92 B26.64 T79.56
Journeyman	W45.92 B26.64 T72.56

Craft: Industrial Painter- Structural Steel

APPRENTICE RATE SCHEDULE

INTERVAL	PERIOD AND RATES									
	SEE	PAINTER	BRIDGES							

Ratio of Apprentices to Journeymen - 1:4

Craft: Industrial Painter- Structural Steel

COMMENTS/NOTES

* Industrial Painters perform work on all industrial structures, such as bridges, water tanks, waste water facilities, refineries, any structural steel work, etc.

These rates apply to: All work in power plants (any aspect). On steeples, on dams, on hangers, transformers, substations, on all open steel, in refineries, tank farms, water/sewerage treatment facilities and on pipelines.

FOREMEN REQUIREMENTS:

- When there are 4 or more Painters on a job, 1 shall be designated a Foreman.
- When there are 15 or more Painters on a job, 1 shall be designated a General Foreman.

The regular workday shall consist of 8 hours between 7:00 AM and 5:30 PM.

SHIFT DIFFERENTIALS:

- The second shift shall receive an additional 10% of the hourly rate, per hour, and the third shift shall receive an additional 15% of the hourly rate, per hour.

OVERTIME:

- Hours in excess of 8 per day, Monday through Friday, and all hours on Saturdays and Sundays shall be paid at time and one-half the regular rate. All hours on holidays shall be paid at double the regular rate.
- Saturday or Sunday may be used to make up a day lost to inclement weather, at straight time.
- Four 10-hour days may be worked, at straight time, Monday through Friday.

RECOGNIZED HOLIDAYS: New Year's Day, President's Day, Memorial Day, July 4th, Labor Day, Presidential Election Day, Veterans' Day, Thanksgiving Day, Christmas Day. Saturday holiday observed the preceding Friday. Sunday holiday observed the following Monday.

**NEW JERSEY DEPARTMENT OF LABOR AND WORKFORCE DEVELOPMENT
PREVAILING WAGE RATE DETERMINATION**

County - UNION

Craft: Industrial Painter- Water Tanks

PREVAILING WAGE RATE

	07/28/20
Foreman	W51.97 B26.29 T78.26
General Foreman	W53.97 B26.29 T80.26
Journeyman	W46.97 B26.29 T73.26

Craft: Industrial Painter- Water Tanks

APPRENTICE RATE SCHEDULE

INTERVAL	PERIOD AND RATES									
	SEE	PAINTER	BRIDGES							

Ratio of Apprentices to Journeymen - 1:4

Craft: Industrial Painter- Water Tanks

COMMENTS/NOTES

* Industrial Painters perform work on all industrial structures, such as bridges, water tanks, waste water facilities, refineries, any structural steel work, etc.

These rates apply to: All new and repaint water tanks (interior and exterior).

FOREMEN REQUIREMENTS:

- When there are 4 or more Painters on a job, 1 shall be designated a Foreman.
- When there are 15 or more Painters on a job, 1 shall be designated a General Foreman.

The regular workday shall consist of 8 hours between 7:00 AM and 5:30 PM.

SHIFT DIFFERENTIALS:

- The second shift shall receive an additional 10% of the hourly rate, per hour, and the third shift shall receive an additional 15% of the hourly rate, per hour.

OVERTIME:

- Hours in excess of 8 per day, Monday through Friday, and all hours on Saturdays and Sundays shall be paid at time and one-half the regular rate. All hours on holidays shall be paid at double the regular rate.
- Saturday or Sunday may be used to make up a day lost to inclement weather, at straight time.
- Four 10-hour days may be worked, at straight time, Monday through Friday.

RECOGNIZED HOLIDAYS: New Year's Day, President's Day, Memorial Day, July 4th, Labor Day, Presidential Election Day, Veterans' Day, Thanksgiving Day, Christmas Day. Saturday holiday observed the preceding Friday. Sunday holiday observed the following Monday.

NEW JERSEY DEPARTMENT OF LABOR AND WORKFORCE DEVELOPMENT
PREVAILING WAGE RATE DETERMINATION

County - UNION

Craft: Industrial Painter-Containment

PREVAILING WAGE RATE

	07/28/20
Journeyman	W38.23 B26.04 T64.27

Craft: Industrial Painter-Containment

COMMENTS/NOTES

Note: These rates shall require no painting, but used in a supporting capacity only, such as wrapping, boxing, fencing, etc. on tanks.

The regular workday shall consist of 8 hours between 7:00 AM and 5:30 PM.

SHIFT DIFFERENTIALS:

- The second shift shall receive an additional 10% of the hourly rate, per hour, and the third shift shall receive an additional 15% of the hourly rate, per hour.
- When 3 shifts are worked, the second shift shall receive 8 hours pay for 7.5 hours of work, and the third shift shall receive 8 hours pay for 7 hours of work.

OVERTIME:

- Hours in excess of 8 per day, Monday through Friday, and all hours on Saturdays shall be paid at time and one-half the regular rate. All hours on Sundays and holidays shall be paid at double the regular rate.
- Saturday or Sunday may be used to make up a day lost to inclement weather, at straight time.
- Four 10-hour days may be worked, at straight time, Monday through Friday.

RECOGNIZED HOLIDAYS: New Year's Day, Memorial Day, July 4th, Labor Day, Presidential Election Day, Veterans' Day, Thanksgiving Day, Christmas Day.

**NEW JERSEY DEPARTMENT OF LABOR AND WORKFORCE DEVELOPMENT
PREVAILING WAGE RATE DETERMINATION**

County - UNION

Craft: Ironworker PREVAILING WAGE RATE

	07/24/20
Rod /Fence Foreman	W46.14 B48.12 T94.26
Rod/Fence Journeyman	W43.14 B48.12 T91.26
Structural Foreman	W48.44 B48.12 T96.56
Structural Journeyman	W45.44 B48.12 T93.56

Craft: Ironworker APPRENTICE RATE SCHEDULE

<u>INTERVAL</u>	<u>PERIOD AND RATES</u>									
6 Months	50%	60%		Yearly	70%	80%	90%			

Ratio of Apprentices to Journeymen - 1:4

Craft: Ironworker COMMENTS/NOTES

HAZARDOUS WASTE WORK: On hazardous waste removal work on a state or federally designated hazardous waste site where the Ironworker is required to wear Level A,B, or C personal protection: + \$3.00 per hour

The regular workday consists of 8 hours between 6:00 AM and 4:30 PM.

FOREMAN REQUIREMENTS:

When there are 2 or more Ironworkers on a job, 1 shall be designated a Foreman.

SHIFT DIFFERENTIALS:

- When a 2 shift schedule is established, the first, or day shift , shall be established on an 8 hour basis .The second shift shall be established on an 8 hour basis, and receive the regular rate plus 15%.
- When a three shift schedule is established, the first shift shall be established on an 8 hour basis, the second shift on a 7.5 hour basis, and the third shift on a 7 hour basis. The first shift shall receive the regular hourly rate, the second shift shall receive the regular rate plus 15%, and the third shift shall receive the regular rate plus 20%.
- When there is no day shift, and a second or third shift is established, it shall be established on an 8 hour basis.
- When an irregular shift is established for the Ironworker (Structural) classification, the rate shall be paid at time and one-half the regular rate, inclusive of benefits. When an irregular shift is established for the Rod/Fence classification, the shift shall be established on an 8 hour basis and receive the regular rate, plus 20%.

OVERTIME:

**NEW JERSEY DEPARTMENT OF LABOR AND WORKFORCE DEVELOPMENT
PREVAILING WAGE RATE DETERMINATION**

County - UNION

- All hours in excess of 8 per day, or before or after an established shift that are not shift work, and all hours on Saturday, shall be paid at time and one-half the regular rate, inclusive of benefits. All hours on Sunday and holidays shall be paid at double the hourly rate, inclusive of benefits. Saturday may be used as a make-up day for a day lost to inclement weather. If Saturday is not a make-up day, all hours on Saturday shall be paid at time and one-half the hourly rate, inclusive of benefits.

- Four 10-hour days may be worked, Monday to Thursday, at straight time. Friday may be used as a make-up day for a day lost to inclement weather. If Friday is not a make-up day, all hours on Friday shall be paid at time and one-half the hourly rate, inclusive of benefits.

RECOGNIZED HOLIDAYS: New Year's Day, Presidents' Day, Memorial Day, July 4th, Labor Day, Presidential Election Day, Veterans Day, Thanksgiving Day, Christmas Day.

**NEW JERSEY DEPARTMENT OF LABOR AND WORKFORCE DEVELOPMENT
PREVAILING WAGE RATE DETERMINATION**

County - UNION

Craft: Laborer - Asbestos & Hazardous Waste Removal

PREVAILING WAGE RATE

	10/20/20
Journeyman (Handler)	W32.98 B23.66 T56.64

Craft: Laborer - Asbestos & Hazardous Waste Removal

APPRENTICE RATE SCHEDULE

INTERVAL	PERIOD AND RATES									
Yearly	19.79	23.09	26.38	29.68						
Benefits	21.51	for	all	intervals						

Ratio of Apprentices to Journeymen - *

* Ratio of apprentices to journeymen shall not be more than one apprentice for the first journeyman and no more than (1) apprentice for each additional three (3) journeymen.

Craft: Laborer - Asbestos & Hazardous Waste Removal

COMMENTS/NOTES

NOTE: These rates apply to work in connection with Asbestos, Radiation, Hazardous Waste, Lead, Chemical, Biological, Mold Remediation and Abatement.

The regular workday shall be 8 hours.

OVERTIME:

- Hours in excess of 8 per day, Monday through Saturday, and all hours on Sunday and holidays shall be paid at time and one-half the regular rate.
- Benefits on ALL overtime hours shall be paid at straight time.

RECOGNIZED HOLIDAYS: New Year's Day, President's Day, Good Friday, Easter, Memorial Day, July 4th, Labor Day, Presidential Election Day, Veterans' Day, Thanksgiving Day, Christmas Day. (Holidays start at 12:00 am).

**NEW JERSEY DEPARTMENT OF LABOR AND WORKFORCE DEVELOPMENT
PREVAILING WAGE RATE DETERMINATION**

County - UNION

Craft: Laborer - Building

PREVAILING WAGE RATE

	05/12/20
Class A Journeyman	W34.85 B30.27 T65.12
Class B Journeyman	W34.10 B30.27 T64.37
Class C Journeyman	W28.99 B30.27 T59.26
Foreman	W39.21 B30.27 T69.48
General Foreman	W43.56 B30.27 T73.83

Craft: Laborer - Building

APPRENTICE RATE SCHEDULE

<u>INTERVAL</u>	<u>PERIOD AND RATES</u>									
	60%	70%	80%	90%						
6 Months										
Benefit	27.02	27.02	27.02	27.02						

Ratio of Apprentices to Journeymen - *

* Ratio of apprentices to journeymen shall not be more than one apprentice for the first journeyman and no more than (1) apprentice for each additional three (3) journeymen.

Craft: Laborer - Building

COMMENTS/NOTES

CLASS A: Specialist laborer including mason tender or concrete pour crew; scaffold builder (scaffolds up to 14 feet in height); operator of forklifts, Bobcats (or equivalent machinery), jack hammers, tampers, motorized tampers and compactors, vibrators, street cleaning machines, hydro demolition equipment, riding motor buggies, conveyors, burners; and nozzle men on gunite work.

CLASS B: Basic laborer - includes all laborer work not listed in Class A or Class C.

CLASS C: Janitorial-type light clean-up work associated with the TURNOVER of a project, or part of a project, to the owner. All other clean-up work is Class B.

The regular workday shall be 8 hours between 6:00 AM and 6:00 PM.

SHIFT DIFFERENTIALS:

- Shift work must run for a minimum of 5 consecutive workdays.
- When a 2-shift schedule is worked, including a day shift, both shifts shall be established on the basis of 8 hours pay for 8 hours worked. The second shift shall receive the regular rate plus an additional 10%.
- When a 3-shift schedule is worked, the day shift shall be established on the basis of 8 hours pay for 8 hours worked, the second shift shall be established on the basis of 8 hours pay for 7.5 hours worked, and the third shift shall be established

**NEW JERSEY DEPARTMENT OF LABOR AND WORKFORCE DEVELOPMENT
PREVAILING WAGE RATE DETERMINATION**

County - UNION

on the basis of 8 hours pay for 7 hours worked. The day shift shall receive the regular rate, the second shift shall receive the regular rate plus an additional 10%, and the third shift shall receive the regular rate plus an additional 15%.

- When a second or third shift is worked with no day shift, the second or third shift shall be established on the basis of 8 hours pay for 8 hours worked. The second shift shall receive the regular rate plus an additional 10%, and the third shift shall receive the regular rate plus an additional 15%.

OVERTIME:

- Hours in excess of 8 per day, or outside the regular workday that are not shift work, Monday through Friday, and all hours on Saturdays shall be paid at time and one-half the regular rate. Saturday may be used as a make-up day (paid at straight time) for a day lost to inclement weather, or for a holiday that is observed during the work week, Monday through Friday. All hours on Sundays and holidays shall be paid at double the regular rate.

- Four 10-hour days may be worked Monday to Thursday, at straight time, with Friday used a make-up day for a day lost to inclement weather. If Friday is not a make-up day, all hours on Friday shall be paid at time and one-half the regular rate.

- Benefits on ALL overtime hours shall be paid at time and one-half.

RECOGNIZED HOLIDAYS: New Year's Day, Presidents' Day, Memorial Day, July 4th, Labor Day, Presidential Election Day, Veterans' Day, Thanksgiving Day, Christmas Day. Sunday holidays observed the following Monday.

**NEW JERSEY DEPARTMENT OF LABOR AND WORKFORCE DEVELOPMENT
PREVAILING WAGE RATE DETERMINATION**

County - UNION

Craft: Laborer - Heavy & General

PREVAILING WAGE RATE

Rates are located in the
"Statewide" rate package

Craft: Laborer - Heavy & General

APPRENTICE RATE SCHEDULE

INTERVAL	PERIOD AND RATES									
1000 Hours	60%	70%	80%	90%						
Benefit	21.78	for	all	intervals						

Ratio of Apprentices to Journeymen - *

* No more than 1 apprentice for the first journeyman and no more than 1 apprentice for each additional 3 journeymen.

Craft: Laborer - Heavy & General

COMMENTS/NOTES

Heavy & General Laborer rates are located in the "Statewide" rate package.

**NEW JERSEY DEPARTMENT OF LABOR AND WORKFORCE DEVELOPMENT
PREVAILING WAGE RATE DETERMINATION**

County - UNION

Craft: Laborer-Residential and Modular Construction

PREVAILING WAGE RATE

	04/01/20
* Skilled Tradesman (only applies to Modular Construction)	W26.55 B5.45 T32.00
Foreman (person directing crew, regardless of his skill classification)	W30.55 B5.45 T36.00
Laborer	W22.55 B5.45 T28.00
Laborer (for single family and stand-alone duplex owned by single owner)	W17.05 B2.95 T20.00

Craft: Laborer-Residential and Modular Construction

APPRENTICE RATE SCHEDULE

<u>INTERVAL</u>	<u>PERIOD AND RATES</u>									
	As shown	800 hours	600 hours	600 hours						
wage & benefits	70%	80%	90%							

Ratio of Apprentices to Journeymen-

One (1) apprentice shall be allowed for the first journeyman on site and no more than one (1) additional apprentice for each additional three (3) journeymen on site.

Craft: Laborer-Residential and Modular Construction

COMMENTS/NOTES

* SKILLED TRADESMAN- any worker doing work not typically done by a Building Laborer. Some examples are installing interior doors, sheet rock, hooking up appliances, installing light fixtures, installing railing systems, etc. Please note where local building codes require that certain work be performed under the supervision of a licensed tradesman (i.e. Plumber, Electrician, etc.) Laborers shall work under such supervision.

RESIDENTIAL CONSTRUCTION- All residential construction (not commercial), single-family, stand-alone duplex houses, townhouses and multi-family buildings of not more than four (4) floors. Each housing unit must be fully and independently functional; each housing unit must have its own kitchen and bathroom. The definition includes all incidental items such as site work, parking areas, utilities, streets and sidewalks. Please note the construction must be Residential in nature. A First Floor at or below grade may contain commercial space not to exceed 50% square footage of the floor; at least 50% of the First Floor must contain living accommodations or related nonresidential uses (e.g. laundry space, recreation/hobby rooms, and/or corridor space). Basement stories below grade used for storage, parking, mechanical systems/equipment, etc., are considered basement stories which are not used in determining the building's height. An attic is an unfinished space located immediately below the roof. Such space is not used in determining a building's height even if used for storage purposes. In addition, barracks and dormitories are not considered residential projects.

MODULAR RESIDENTIAL CONSTRUCTION- all aspects of modular residential construction (not commercial) at the site of installation of structures of no more than four (4) stories, including all excavation and site preparation, footings and

**NEW JERSEY DEPARTMENT OF LABOR AND WORKFORCE DEVELOPMENT
PREVAILING WAGE RATE DETERMINATION**

County - UNION

foundation systems whether poured on-site or prefabricated, all underground waterproofing, underground utilities, concrete slabs, sidewalks, driveways, paving, hardscape and landscaping. Please note the construction must be Residential as defined above. All work performed by the Set Crew (the crew of workers who set the modular boxes on the foundation), including the rigging, setting, attaching and assembly of all modules and structural members, preparation of the foundation to accept modules, such as sill plates, connection of all in-module and under-module connections including, but not limited to, plumbing, electrical, HVAC, fire suppression, CATS, telephone, television/internet, and fiber optic, the building or installation of any porches or decks regardless of material or method of construction, the on-site installation of, or completion of any roof system, doors, windows and fenestrations, including flashing, gutter and soffit systems, waterproofing, insulation and interior and exterior trim work, and painting. Please note that modular construction does not include on-site stick built construction, tip up construction or panel built construction.

The regular workday shall be 8 hours between 6:00 AM and 6:00 PM.

OVERTIME:

Hours worked in excess of 8 per day/40 per week, Monday through Saturday, and all hours worked on Sunday and holidays shall be paid at time and one-half the hourly rate.

RECOGNIZED HOILDAYS:

New Year's Day, Martin Luther King Day, Memorial Day, July 4th, Labor Day, Thanksgiving Day and Christmas Day.

**NEW JERSEY DEPARTMENT OF LABOR AND WORKFORCE DEVELOPMENT
PREVAILING WAGE RATE DETERMINATION**

County - UNION

Craft: Millwright PREVAILING WAGE RATE

	05/01/20
Foreman	W59.32 B35.01 T94.33
Journeyman	W51.58 B30.52 T82.10

Craft: Millwright APPRENTICE RATE SCHEDULE

INTERVAL	PERIOD AND RATES									
6 Months	40%	55%	65%	80%	90%					
Benefits	58% of	Appren	tice	Wage	Rate	for all	intervals	+ \$.60		

Ratio of Apprentices to Journeymen - 1:3

Craft: Millwright COMMENTS/NOTES

FOREMAN REQUIREMENTS:

- When there are 2 or more Millwrights on a job, 1 shall be designated as a Foreman.
- When there are 21 or more Millwrights on a job, 2 shall be designated as Foremen.

The regular workday shall consist of 8 hours, starting between 6:00 AM and 9:00 AM.

SHIFT DIFFERENTIALS:

- When a 2 shift schedule (including a day shift) is established, the day shift shall be established on an 8 hour basis. The second shift shall be established on an 8 hour basis, and receive the regular rate plus 15%, inclusive of benefits.
- When a three shift schedule is established, the first shift shall be established on an 8 hour basis, the second shift on a 7.5 hour basis, and the third shift on a 7 hour basis. The first shift shall receive the regular hourly rate, the second shift shall receive the regular rate plus 15% and the third shift shall receive the regular rate plus 20%, inclusive of benefits.
- When there is no day shift, and a second or third shift is established, it shall be established on an 8 hour basis. The second shift shall receive the regular rate plus 15% and the third shift shall receive the regular rate plus 20%, inclusive of benefits.
- When an irregular shift must be established, this shift shall receive the regular rate plus 15%, inclusive of benefits.

OVERTIME:

- All hours in excess of 8 per day, or before or after an established shift that are not shift work, and all hours on Saturdays shall be paid at time and one-half the hourly rate, inclusive of benefits. All hours on Sundays and holidays shall be paid at double the hourly rate, inclusive of benefits.
- Four 10-hour days may be worked, Monday to Thursday, at straight time. Friday may be used as a make-up day for a day lost due to inclement weather. If Friday is not a make-up day, all hours on Friday shall be paid at time and one-half the hourly rate, inclusive of benefits.

RECOGNIZED HOLIDAYS: New Year's Day, Presidents' Day, Memorial Day, July 4th, Labor Day, Veterans' Day, Thanksgiving Day, Christmas Day. Sunday holidays will be observed the following Monday. Veterans' Day may be

**NEW JERSEY DEPARTMENT OF LABOR AND WORKFORCE DEVELOPMENT
PREVAILING WAGE RATE DETERMINATION**

County - UNION

substituted for the day after Thanksgiving.

**NEW JERSEY DEPARTMENT OF LABOR AND WORKFORCE DEVELOPMENT
PREVAILING WAGE RATE DETERMINATION**

County - UNION

Craft: **Operating Engineer** **PREVAILING WAGE RATE**

Rates are located in the
"Statewide" rate package

Craft: **Operating Engineer** **APPRENTICE RATE SCHEDULE**

INTERVAL	PERIOD AND RATES									
Yearly	60%	70%	80%	90%						

Ratio of Apprentices to Journeymen - *

* 1 apprentice for each piece of heavy equipment. At least 10 pieces of heavy equipment or a minimum of 5 Operating Engineers must be on site.

Craft: **Operating Engineer** **COMMENTS/NOTES**

Operating Engineer rates are located in the "Statewide" rate package.

**NEW JERSEY DEPARTMENT OF LABOR AND WORKFORCE DEVELOPMENT
PREVAILING WAGE RATE DETERMINATION**

County - UNION

Craft: Operating Engineer - Field Engineer

PREVAILING WAGE RATE

Rates are located in the
"Statewide" rate package

Craft: Operating Engineer - Field Engineer

APPRENTICE RATE SCHEDULE

INTERVAL	PERIOD AND RATES									
Yearly	70%	75%	of Rod/	Chainman	Wage					
Yearly			80%	90%	Transit/	Instrument	man	Wage		

Ratio of Apprentices to Journeymen - *

* No more than 1 Field Engineer Apprentice per Survey Crew.

Craft: Operating Engineer - Field Engineer

COMMENTS/NOTES

Operating Engineer - Field Engineer rates are located in the "Statewide" rate package.

**NEW JERSEY DEPARTMENT OF LABOR AND WORKFORCE DEVELOPMENT
PREVAILING WAGE RATE DETERMINATION**

County - UNION

Craft: Painter - Line Striping

PREVAILING WAGE RATE

	01/23/20
Apprentice (1st year)	W27.50 B11.90 T39.40
Apprentice (2nd year)	W31.50 B20.60 T52.10
Foreman (Charge Person)	W40.15 B21.38 T61.53
Journeyman 1 (at least 1 year of working exp. as a journeyman)	W35.38 B21.38 T56.76
Journeyman 2 (at least 2 years of working exp. as a journeyman)	W39.15 B21.38 T60.53

Craft: Painter - Line Striping

COMMENTS/NOTES

OVERTIME:

Hours in excess of 8 per day, Monday through Saturday, and all hours on Sundays and holidays shall be paid at time and one-half the hourly rate.

RECOGNIZED HOLIDAYS: New Year's Day, Presidents' Day, Memorial Day, July 4th, Labor Day, Veterans Day, Thanksgiving Day and Christmas Day. Veterans Day may be substituted for the day after Thanksgiving.

**NEW JERSEY DEPARTMENT OF LABOR AND WORKFORCE DEVELOPMENT
PREVAILING WAGE RATE DETERMINATION**

County - UNION

Craft: Paperhanger - New Construction

PREVAILING WAGE RATE

	09/24/20
Foreman	W45.05 B26.56 T71.61
Journeyman	W40.95 B26.56 T67.51

Craft: Paperhanger - New Construction

APPRENTICE RATE SCHEDULE

INTERVAL	PERIOD AND RATES									
	SEE	COMME R	CIAL	PAINTER	NEW	CONSTR UC	TION			

Ratio of Apprentices to Journeymen - 1:4

Craft: Paperhanger - New Construction

COMMENTS/NOTES

FOREMEN REQUIREMENTS:

- When there are 4 or more Paperhangers on a job, 1 shall be designated a Foreman.

The regular workday shall consist of 8 hours between 7:00 AM and 5:30 PM.

SHIFT DIFFERENTIALS:

- The second shift shall receive an additional 10% of the hourly rate, per hour, and the third shift shall receive an additional 15% of the hourly rate, per hour.

OVERTIME:

- Hours in excess of 8 per day, Monday through Friday, and all hours on Saturdays shall be paid at time and one-half the regular rate. All hours on Sundays and holidays shall be paid at double the regular rate.

- Saturday or Sunday may be used to make up a day lost to inclement weather, at straight time.

- Four 10-hour days may be worked, at straight time, Monday through Friday.

RECOGNIZED HOLIDAYS: New Year's Day, President's Day, Memorial Day, July 4th, Labor Day, General Election Day, Veterans' Day, Thanksgiving Day, Christmas Day.

**NEW JERSEY DEPARTMENT OF LABOR AND WORKFORCE DEVELOPMENT
PREVAILING WAGE RATE DETERMINATION**

County - UNION

Craft: Paperhanger - Renovation

PREVAILING WAGE RATE

	09/24/20
Foreman	W33.94 B20.70 T54.64
Journeyman	W30.86 B20.70 T51.56

Craft: Paperhanger - Renovation

APPRENTICE RATE SCHEDULE

INTERVAL	PERIOD AND RATES									
		SEE	COMME R	CIAL	PAINTER	NEW	CONSTR UC	TION		

Ratio of Apprentices to Journeymen - 1:4

Craft: Paperhanger - Renovation

COMMENTS/NOTES

NOTE: These rates may only be used on jobs where no major alterations occur, and where not more than 3 other trades are present on the job, but may NOT, under any circumstances, be used for work on bridges, stacks, elevated tanks, or generating stations.

FOREMEN REQUIREMENTS:

- When there are 4 or more Paperhangers on a job, 1 shall be designated a Foreman.

OVERTIME:

- Hours in excess of 8 per day and 40 per week shall be paid at time and one-half the regular rate.

- Four 10-hour days may be worked, at straight time, Monday through Sunday.

**NEW JERSEY DEPARTMENT OF LABOR AND WORKFORCE DEVELOPMENT
PREVAILING WAGE RATE DETERMINATION**

County - UNION

hours on Sundays and holidays shall be paid at double time, inclusive of benefits.

NOTE: Maintenance work is work to repair, restore, or improve the efficiency of existing facilities. This does NOT apply to ANY new construction.

RECOGNIZED HOLIDAYS: New Year's Day, Presidents' Day, Memorial Day, July 4th, Labor Day, Presidential Election Day, Veterans' Day, Thanksgiving Day, Christmas Day. Sunday holidays are observed the following Monday.

**NEW JERSEY DEPARTMENT OF LABOR AND WORKFORCE DEVELOPMENT
PREVAILING WAGE RATE DETERMINATION**

County - UNION

Craft: Plasterer

PREVAILING WAGE RATE

See Bricklayer, Stone Mason Rates

Craft: Plasterer

COMMENTS/NOTES

See BRICKLAYER, STONE MASON Rates

**NEW JERSEY DEPARTMENT OF LABOR AND WORKFORCE DEVELOPMENT
PREVAILING WAGE RATE DETERMINATION**

County - UNION

Craft: Plumber PREVAILING WAGE RATE

	05/01/20
Foreman	W60.69 B37.32 T98.01
General Foreman	W64.62 B37.32 T101.94
Journeyman	W56.19 B37.32 T93.51

Craft: Plumber APPRENTICE RATE SCHEDULE

INTERVAL	PERIOD AND RATES									
Yearly	30%	45%	55%	65%	75%					
Benefits	14.31	20.83	22.72	24.52	26.50					

Ratio of Apprentices to Journeymen - *

* Employers may employ 1 apprentice on any job where 1 or 2 journeymen are employed. Thereafter, 1 apprentice may be employed for every 4 journeymen.

Craft: Plumber COMMENTS/NOTES

FOREMAN REQUIREMENTS:

- On any job having 2 or more Plumbers, 1 must be designated a Foreman.
- On any job having 9 or more Plumbers, 2 shall be designated as Foremen.

The regular workday shall consist of 8 hours between 7:00 AM and 4:30 PM.

SHIFT DIFFERENTIALS:

- Shift work must continue for a minimum of 5 consecutive workdays.
- When two shifts are worked, the second shift shall work 7.5 hours and receive 8 hours pay, at a rate equal to the hourly rate plus 10%, inclusive of benefits.
- When a third shift is worked, the third shift shall work 7 hours and receive 8 hours pay, at a rate equal to the hourly rate plus 15%, inclusive of benefits.

OVERTIME:

- All hours in excess of 8 per day, or before or after the regular workday that are not shift work, Monday through Friday, and all hours on Saturday, shall be paid at time and one-half the regular rate, inclusive of benefits. All hours on Sunday and holidays, shall be paid at double the hourly rate, inclusive of benefits.
- Four 10-hour days may be worked, Monday to Thursday, at straight time. Friday may be used as a make-up day for a day lost due to inclement weather. If Friday is not a make-up day, all hours on Friday shall be paid at time and one-half, inclusive of benefits.

RECOGNIZED HOLIDAYS: New Year's Day, Presidents' Day, Memorial Day, July 4th, Labor Day, Presidential Election Day, Veterans' Day, Thanksgiving Day, Christmas Day. Sunday holidays will be observed the following Monday.

**NEW JERSEY DEPARTMENT OF LABOR AND WORKFORCE DEVELOPMENT
PREVAILING WAGE RATE DETERMINATION**

County - UNION

Craft: Roofer PREVAILING WAGE RATE

	06/04/20
Foreman	W42.77 B28.03 T70.80
Journeyman	W39.77 B28.03 T67.80

Craft: Roofer APPRENTICE RATE SCHEDULE

INTERVAL	PERIOD AND RATES									
6 Months	15.90	19.89	23.86	27.84	31.82	35.79				
Benefits	2.10	2.10	25.28	25.28	25.28	25.28				

Ratio of Apprentices to Journeymen - *

- * A) For roofing jobs that are of the 1 or single ply nature: 1:2 or fraction thereof
- B) For roofing jobs on new built up roofs: 1:3 or fraction thereof
- C) For roofing jobs that are of a tear-off nature: 1:2 or fraction thereof
- D) For roofing jobs {not requiring complete removal of existing systems, installation done over existing roof}: 1:3 or fraction thereof

Craft: Roofer COMMENTS/NOTES

APPRENTICE RATE SCHEDULE FOR THOSE APPRENTICES ENTERING PROGRAM AFTER 4-1-17:

INTERVAL	PERIOD AND RATES									
6 Months	15.90	19.89	23.86	25.85	27.84	29.83	31.82	35.79		
Benefits	2.10	2.10	25.28	25.28	25.28	25.28	25.28	25.28		

Pitch: +.50 per hour

Mop Man: +.30 per hour

The regular workday consists of 8 hours between 8:00 AM and 4:30 PM.

OVERTIME:

Hours in excess of 8 per day, or before or after the regular workday, Monday through Friday, and all hours on Saturdays, Sundays, and holidays shall be paid at time and one-half the regular rate.

RECOGNIZED HOLIDAYS: New Year's Day, Good Friday, Memorial Day, July 4th, Labor Day, Presidential Election Day, Veterans' Day, Thanksgiving Day, Christmas Day.

**NEW JERSEY DEPARTMENT OF LABOR AND WORKFORCE DEVELOPMENT
PREVAILING WAGE RATE DETERMINATION**

County - UNION

Craft: Sheet Metal Sign Installation

PREVAILING WAGE RATE

	04/16/20
Foreman	W38.29 B35.55 T73.84
Journeyman	W36.79 B35.55 T72.34

Craft: Sheet Metal Sign Installation

APPRENTICE RATE SCHEDULE

INTERVAL	PERIOD AND RATES									
1000 hours	35%	40%	45%	50%	55%	60%	65%	70%	75%	80%
Benefits	12.03	13.71	15.39	17.09	19.21	20.92	22.65	24.38	26.10	27.82

Ratio of Apprentices to Journeymen - 1:3

Craft: Sheet Metal Sign Installation

COMMENTS/NOTES

FOREMAN REQUIREMENT:

When there are 6 or more Sheet Metal Sign Installers on a job, 1 shall be designated a Foreman.

The regular workday consists of 8 hours, between 7:00 AM and 3:30 PM.

OVERTIME:

Hours before or after the regular workday, Monday through Friday, and all hours worked on Saturday shall be paid at time and one-half the hourly rate. All hours on Sunday and holidays shall be paid at double the hourly rate.

Four(4) 10 hour days may be worked, Monday through Friday, at straight time, for projects lasting at least one week in duration. The fifth day may be used as a make-up day at straight time for a day lost due to inclement weather. However, if the fifth day is not a make-up day, all hours worked will be paid at time and one-half the hourly rate.

RECOGNIZED HOLIDAYS: New Year's Day, Presidents' Day, Good Friday, Memorial Day, July 4th, Labor Day, Veterans' Day, Thanksgiving Day and the day after, Christmas Day. Saturday holidays observed the preceding Friday, Sunday holidays observed the following Monday.

**NEW JERSEY DEPARTMENT OF LABOR AND WORKFORCE DEVELOPMENT
PREVAILING WAGE RATE DETERMINATION**

County - UNION

Craft: Sheet Metal Worker

PREVAILING WAGE RATE

	06/09/20
Foreman	W53.62 B46.85 T100.47
General Foreman	W54.62 B46.85 T101.47
Journeyman	W50.12 B46.85 T96.97

Craft: Sheet Metal Worker

APPRENTICE RATE SCHEDULE

INTERVAL	PERIOD AND RATES									
Yearly	35%	45%	55%	65%	of	Journey	man	Wage	Rate	
Benefit	35%	45%	55%	65%	of	Journey	man	Benefit	Rate	

Ratio of Apprentices to Journeymen - 1:4

Craft: Sheet Metal Worker

COMMENTS/NOTES

FOREMAN REQUIREMENTS:

- When there are 2 or more Sheet Metal Workers on a project, 1 must be designated a Foreman.
- When there are 17 or more Sheet Metal Workers on a project, 1 must be designated a General Foreman.
- When there is only 1 Sheet Metal Worker (1 Journeyman) on a project, he/she shall receive \$1.00 more than the regular Journeyman's rate.

The regular workday is 8 hours between 7:00 AM and 4:30 PM.

SHIFT DIFFERENTIAL:

- 2nd Shift (3:30 PM - 12:00 AM) : +17% of regular hourly rate
- Shift work must run for a minimum of 5 consecutive workdays.

OVERTIME:

- Hours in excess of 8 per day, or before or after the regular workday, that are not shift work, and the first 10 hours on Saturdays shall be paid at time and one-half of the regular rate, inclusive of benefits. Hours in excess of 10 per day on Saturday, and all hours on Sundays and holidays shall be at double the regular rate, inclusive of benefits.
- Four 10-hour days may be worked, Monday through Friday, at straight time, with hours in excess of 10 per day, and hours in excess of 40 per week paid at the overtime rates listed above.

RECOGNIZED HOLIDAYS: New Year's Day, Presidents' Day, Good Friday, Memorial Day, July 4th, Labor Day, Presidential Election Day, Veterans' Day, Thanksgiving Day, Christmas Day. Sunday holidays will be observed the following Monday.

**NEW JERSEY DEPARTMENT OF LABOR AND WORKFORCE DEVELOPMENT
PREVAILING WAGE RATE DETERMINATION**

County - UNION

Craft: Sprinkler Fitter

PREVAILING WAGE RATE

	07/01/20
Foreman	W66.89 B32.13 T99.02
General Foreman	W70.15 B32.13 T102.28
Journeyman	W62.64 B32.13 T94.77

Craft: Sprinkler Fitter

APPRENTICE RATE SCHEDULE

INTERVAL	PERIOD AND RATES									
1000 Hours									80%	85%
Benefits							Intervals	9 to 10	Jourymn	Ben.

APPRENTICE RATE SCHEDULE FOR THOSE APPRENTICES REGISTERED AS OF 7-1-13:

INTERVAL	PERIOD AND RATES									
1000 hours	25%	30%	40%	45%	55%	60%	70%	75%	85%	90%
Benefits	12.33	12.33	25.63	25.63	25.63	25.63	Intervals	7 to 10	receive	Journeyman Ben.

Craft: Sprinkler Fitter

COMMENTS/NOTES

The regular workday consists of 8 consecutive hours between 6:00 AM and 4:30 PM.

FOREMAN REQUIREMENTS:

- The first Sprinkler Fitter on the job must be designated a Foreman.
- On any job having 12 or more Sprinkler Fitters, one must be designated a General Foreman.

SHIFT DIFFERENTIALS:

- Shift work must run for a minimum of 2 consecutive workdays.
- 2nd and 3rd shift shall receive an additional 15% of the regular rate, per hour.
- Any "off hours" shift starting at 8:00 PM or later shall receive an additional 25% of the regular rate, per hour.

OVERTIME:

The first 2 hours in excess of 8 per day, after the regular workday that are not shift work, Monday through Friday, shall be paid at time and one-half the regular rate. Hours worked in excess of 10 per day, Monday through Friday, and all hours on Saturday, Sunday and holidays, shall be paid double the regular rate.

Four 10 hour days may be worked, Monday through Friday, at straight-time.

RECOGNIZED HOLIDAYS: New Year's Day, Presidents' Day, Good Friday, Memorial Day, July 4th, Labor Day, Presidential Election Day, Veterans Day, Thanksgiving Day, Christmas Day.

**NEW JERSEY DEPARTMENT OF LABOR AND WORKFORCE DEVELOPMENT
PREVAILING WAGE RATE DETERMINATION**

County - UNION

Craft: Tile Finisher-Marble PREVAILING WAGE RATE

	06/02/20
Finisher	W47.92 B35.14 T83.06

Craft: Tile Finisher-Marble APPRENTICE RATE SCHEDULE

INTERVAL	PERIOD AND RATES									
750 Hours	40%	45%	50%	55%	60%	65%	70%	75%	85%	95%

Ratio of Apprentices to Journeymen - 1:4

Craft: Tile Finisher-Marble COMMENTS/NOTES

OVERTIME:

Hours in excess of 7 per day, Monday through Friday, and the first 7 hours on Saturdays shall be paid at time and one half the regular rate, inclusive of benefits. Hours in excess of 7 on Saturdays and all hours on Sundays and holidays shall be paid at double the regular rate, inclusive of benefits.

RECOGNIZED HOLIDAYS: New Year's Day, Presidents' Day, Good Friday, Memorial Day, July 4th, Labor Day, Columbus Day, Veterans' Day, Thanksgiving Day and the day after, Christmas Day. Sunday holidays observed the following Monday.

**NEW JERSEY DEPARTMENT OF LABOR AND WORKFORCE DEVELOPMENT
PREVAILING WAGE RATE DETERMINATION**

County - UNION

Craft: Tile Setter - Ceramic

PREVAILING WAGE RATE

	06/02/20
Finisher	W46.21 B31.31 T77.52
Setter	W60.09 B34.63 T94.72

Craft: Tile Setter - Ceramic

APPRENTICE RATE SCHEDULE

INTERVAL	PERIOD AND RATES									
750 Hours	35%	40%	50%	55%	60%	65%	70%	75%	80%	90%

Ratio of Apprentices to Journeymen - 1:4

Craft: Tile Setter - Ceramic

COMMENTS/NOTES

OVERTIME:

Hours in excess of 7 per day, and the first 10 hours on Saturdays shall be paid at time and one-half the hourly rate. All hours on Saturdays after 10 hours shall be paid double the hourly rate. All hours on Sundays and holidays shall be paid at double the hourly rate.

RECOGNIZED HOLIDAYS: New Year's Day, Memorial Day, July 4th, Labor Day, Thanksgiving Day, Christmas Day.

**NEW JERSEY DEPARTMENT OF LABOR AND WORKFORCE DEVELOPMENT
PREVAILING WAGE RATE DETERMINATION**

County - UNION

Craft: Tile Setter - Marble

PREVAILING WAGE RATE

	06/02/20
Tile Setter	W60.35 B37.39 T97.74

Craft: Tile Setter - Marble

APPRENTICE RATE SCHEDULE

INTERVAL	PERIOD AND RATES									
750 Hours	40%	45%	50%	55%	60%	65%	70%	75%	85%	95%

Ratio of Apprentices to Journeymen - 1:4

Craft: Tile Setter - Marble

COMMENTS/NOTES

OVERTIME:

Hours in excess of 7 per day, Monday through Friday, and the first 7 hours on Saturdays shall be paid at time and one-half the regular rate, inclusive of benefits. Hours in excess of 7 on Saturdays, and all hours on Sundays and holidays shall be paid at double the regular rate, inclusive of benefits.

RECOGNIZED HOLIDAYS: New Year's Day, Presidents' Day, Good Friday, Memorial Day, July 4th, Labor Day, Columbus Day, Veterans' Day, Thanksgiving Day and the day after, Christmas Day. Sunday holidays observed the following Monday.

**NEW JERSEY DEPARTMENT OF LABOR AND WORKFORCE DEVELOPMENT
PREVAILING WAGE RATE DETERMINATION**

County - UNION

Craft: Tile Setter - Mosaic & Terrazzo

PREVAILING WAGE RATE

	07/09/20
Grinder or Assistant	W55.82 B37.31 T93.13
Mechanic	W57.42 B37.33 T94.75
Terrazzo Resinous Worker	W47.92 B30.24 T78.16

Craft: Tile Setter - Mosaic & Terrazzo

APPRENTICE RATE SCHEDULE

INTERVAL	PERIOD AND RATES									
750 Hours	50%	55%	60%	65%	70%	75%	85%	95%	100%	

Ratio of Apprentices to Journeymen - 1:5

Craft: Tile Setter - Mosaic & Terrazzo

COMMENTS/NOTES

APPRENTICE RATE SCHEDULE FOR THOSE APPRENTICES ENTERING PROGRAM AFTER 7-1-17:

INTERVAL	PERIOD AND RATES						
1500 Hours	35%	45%	60%	70%	80%	90%	100%

The regular workday consists of 7 hours, between 8:00 AM and 3:30 PM.

OVERTIME:

- Hours in excess of 7 per day, or before or after the regular workday, Monday through Friday, and all hours on Saturdays shall be paid at time and one-half the hourly rate. All hours on Sundays and holidays shall be paid at double the hourly rate.

RECOGNIZED HOLIDAYS: New Year's Day, Presidents' Day, Good Friday, Monday after Easter, Memorial Day, July 4th, Labor Day, Columbus Day, Veterans' Day, Thanksgiving Day and the day after, Christmas Day. Sunday holidays observed the following Monday.

**NEW JERSEY DEPARTMENT OF LABOR AND WORKFORCE DEVELOPMENT
PREVAILING WAGE RATE DETERMINATION**

County - UNION

Craft: Truck Driver

PREVAILING WAGE RATE

	05/01/20
Bucket, Utility, Pick-up, Fuel Delivery trucks	W39.21 B38.05 T77.26
Dump truck, Asphalt Distributor, Tack Spreader	W39.21 B38.05 T77.26
Euclid-type vehicles (large, off-road equipment)	W39.31 B38.05 T77.36
Helper on Asphalt Distributor truck	W39.21 B38.05 T77.26
Slurry Seal, Seeding/Fertilizing/ Mulching truck	W39.21 B38.05 T77.26
Straight 3-axle truck	W39.21 B38.05 T77.26
Tractor Trailer (all types)	W39.31 B38.05 T77.36
Vacuum or Vac-All truck (entire unit)	W39.21 B38.05 T77.26
Winch Trailer	W39.41 B38.05 T77.46

Craft: Truck Driver

COMMENTS/NOTES

BLENDED RATE:

When a truck driver is performing work on the site and also serving as a material delivery driver, the driver shall be paid a "blended rate" which shall be 80% of the above-listed wage rates, plus the full benefit rate. This rate shall be used when the driver "round robins" for a minimum of 6 hours during the work day.

HAZARDOUS WASTE REMOVAL:

- On hazardous waste removal work on a State designated hazardous waste site where the driver is in direct contact with hazardous materials and when personal protective equipment is required for respiratory, skin, and eye protection, the driver shall receive an additional \$3.00 per hour (with or without protective gear).
- A hazardous waste related certified worker at a designated hazardous waste site who is not working in a zone requiring level A, B or C personal protection shall receive an additional \$1.00 per hour.

TRUCK FOREMAN: \$.75 cents per hour above regular rate. Overtime shall be increased accordingly.

**NEW JERSEY DEPARTMENT OF LABOR AND WORKFORCE DEVELOPMENT
PREVAILING WAGE RATE DETERMINATION**

County - UNION

The regular workday shall be 8 hours, starting between 6:00 AM and 8:00 AM.

SHIFT DIFFERENTIAL:

- Shifts starting at 4:00 PM (2nd Shift): + \$3.00 per hour.
- Shifts starting at 12:00 AM (midnight/3rd Shift): time and one-half the hourly rate.
- Shifts starting at a time other than from 6:00 AM to 8:00 AM, when such hours are mandated by the project owner: + \$3.00 per hour.

OVERTIME:

- Hours in excess of 8 per day, or before or after the regular workday, Monday through Friday, that are not shift work, and all hours on Saturdays shall be paid at time and one-half the hourly rate. All hours on Sundays and holidays shall be paid at double the hourly rate.
 - Employees may work four 10-hour days at straight time, Monday through Thursday, with Friday used as a make-up day for a lost day. If Friday is not a make-up day, then all hours on Friday shall be paid at time and one-half the hourly rate.
 - Benefits on overtime shall be \$36.80.
- As of 5-1-20, benefits on overtime shall be \$37.80.

RECOGNIZED HOLIDAYS: New Year's Day, President's Day, Memorial Day (Decoration Day), July 4th, Labor Day, Presidential Election Day, Veteran's Day, Thanksgiving Day, Christmas Day. Sunday holidays will be observed the following Monday. The day after Thanksgiving may be substituted for Veteran's Day.

**NEW JERSEY DEPARTMENT OF LABOR AND WORKFORCE DEVELOPMENT
PREVAILING WAGE RATE DETERMINATION**

County - UNION

Craft: Truck Driver-Material Delivery Driver

PREVAILING WAGE RATE

	04/01/20
Driver	W25.60 B15.71 T41.31

Craft: Truck Driver-Material Delivery Driver

COMMENTS/NOTES

BLENDED RATE:

When a truck driver is performing work on the site and also serving as a material delivery driver, the driver shall be paid a "blended rate". See the "Truck Driver" craft for the blended rates.

Truck Foreman/Shop Steward: +\$0.25 per hour

SHIFT DIFFERENTIALS:

- 2nd Shift shall receive an additional \$0.50 per hour
- 3rd Shift shall receive time and one-half the hourly rate.

OVERTIME:

- Hours in excess of 8 per day, or before or after the regular workday that are not shift work, Monday through Friday, and all hours on Saturday shall be paid at time and one-half the hourly rate. All hours on Sunday and holidays shall be paid at double the hourly rate.

RECOGNIZED HOLIDAYS: New Year's Day, President's Day, Memorial Day (Decoration Day), July 4th, Labor Day, Presidential Election Day, Veterans' Day, Thanksgiving Day, Christmas Day. Sunday holidays will be observed the following Monday. The day after Thanksgiving may be substituted for Veterans' Day.

**NEW JERSEY DEPARTMENT OF LABOR AND WORKFORCE DEVELOPMENT
PREVAILING WAGE RATE DETERMINATION**

County - UNION

Craft: Welder

PREVAILING WAGE RATE

Welder

Craft: Welder

COMMENTS/NOTES

Welders rate is the same as the craft to which the welding is incidental .

STATEWIDE RATES

OPERATING ENGINEERS **Rates Expiration Date :**

{For apprentice rates refer to "Operating Engineers" apprentice rates in any county rate package}

The regular workday consists of 8 hours, Monday to Friday, between 6:00 AM and 4:30 PM.

SHIFT DIFFERENTIALS:

- Shift work must run for 5 consecutive workdays.
- When 2 shifts are worked, the second shift shall receive an additional 10% of the regular rate inclusive of benefits, per hour.
- When 3 shifts are worked, the second shift shall receive 8 hours pay for 7.5 hours of work, plus an additional 10% of the regular rate inclusive of benefits, per hour. The third shift shall receive 8 hours pay for 7 hours of work, plus an additional 15% of the regular rate inclusive of benefits, per hour.
- When such hours are mandated by the project owner, a shift that starts between 8:00 PM and midnight and ends by 6:00 AM Saturday, or that starts after 8:00 PM on Sunday, provided there are consecutive hours of work within the shift, shall receive an additional 15% of the regular rate, inclusive of benefits.
- On Highway, Road, Street, and Sewer projects irregular shifts starting between 5:00 PM and 12:00 AM may be worked Monday through Friday, and shall receive an additional 15% of the regular rate, inclusive of benefits. When working with other trades that receive a higher irregular shift rate, the Operating Engineer shall also receive the higher irregular shift rate.

OVERTIME:

- Hours in excess of 8 per day, or outside of the regular workday, Monday through Friday, that are not shift work, and all hours on Saturdays shall be paid at time and one-half the regular rate, inclusive of benefits. All hours on Sundays and holidays shall be paid at double the regular rate, inclusive of benefits.
- Four 10-hour days may be worked, Monday through Thursday, at straight time, with all hours on Friday paid at time and one-half the regular rate, inclusive of benefits.

RECOGNIZED HOLIDAYS: New Year's Day, Presidents' Day, Memorial Day, July 4th, Labor Day, Presidential Election Day, Veterans Day, Thanksgiving Day, Christmas Day. Sunday holidays observed the following Monday. When all trades on a particular job site agree, the day after Thanksgiving may be substituted for Veteran's Day.

On hazardous waste removal work or asbestos removal work, on a state or federally designated hazardous waste site, where the operating engineer is in direct contact with hazardous material and when personal protective equipment is required for respiratory, skin, and eye protection, the operating engineer shall receive an additional 20% of the hourly wage, per hour.

OPERATING ENGINEERS **Rates Expiration Date :**

Effective Dates:

	07/01/2020		07/01/2021	07/01/2022
Rate	Fringe	Total	Total	Total
53.23	34.50	87.73	90.03	92.28

CLASSIFICATIONS:

A-Frame

Backhoe (combination)

Boom Attachment on loaders (Except pipehook)

Boring & Drilling Machine

Brush Chopper, Brush Shredder, Tree Shredder, Tree Shearer

Bulldozer, finish grade

Cableway

Carryall

Concrete Pump

Concrete Pumping System (Pumpcrete & similar types)

Conveyor, 125 feet or longer

Drill Doctor (Duties include dust collector and maintenance)

Front End Loader (2 cu. yds. but less than 5 cu. yds.)

Grader, finish

Groove Cutting Machine (ride-on type)

Heater Planer

Hoist: Outside Material Tower Hoist (all types including steam, gas, diesel, electric, air hydraulic, single and double drum, concrete, brick shaft caisson, snorkle roof, and other similar types, Except Chicago-boom type) * receives an additional \$1.00 per hour on 100 ft. up to 199 ft. total height, and an additional \$2.00 per hour on 200 ft. and over total height.

Hydraulic Crane (10 tons & under)

Hydraulic Dredge

Hydro-Axe

Hydro-Blaster

OPERATING ENGINEERS **Rates Expiration Date :**

Effective Dates:

	07/01/2020		07/01/2021	07/01/2022
Rate	Fringe	Total	Total	Total
53.23	34.50	87.73	90.03	92.28

CLASSIFICATIONS:

Jack (screw, air hydraulic, power-operated unit, or console type, Except hand jack or pile load test type)

Log Skidder

Pan

Paver, concrete

Plate & Frame Filter Press

Pumpcrete (unit type)

Pumpcrete, Squeezecrete, or Concrete Pumping machine (regardless of size)

Scraper

Side Boom

Straddle Carrier (Ross and similar types)

Whiphammer

Winch Truck (hoisting)

OPERATING ENGINEERS **Rates Expiration Date :**

Effective Dates:

	07/01/2020		07/01/2021	07/01/2022
Rate	Fringe	Total	Total	Total
51.32	34.50	85.82	88.12	90.37

CLASSIFICATIONS:

- Asphalt Curbing Machine
- Asphalt Plant Engineer
- Asphalt Spreader
- Autograde Curb Trimmer & Sidewalk Shoulder Slipform (CMI & similar types)
- Autograde Curecrete Machine (CMI & similar types)
- Autograde Tube Finisher & Texturing Machine (CMI & similar types)
- Bar Bending Machines (Power)
- Batcher, Batching Plant, & Crusher [On Site]
- Belt Conveyor System
- Boom-Type Skimmer Machine
- Bridge Deck Finisher
- Bulldozer (all sizes)
- Captain (Power Boats)
- Car Dumper (railroad)
- Compressor & Blower unit for loading/unloading of concrete, cement, fly ash, or similar type materials (used independently or truck-mounted)
- Compressor (2 or 3 battery)
- Concrete Breaking Machine
- Concrete Cleaning/Decontamination Machine
- Concrete Finishing Machine
- Concrete Saw or Cutter (ride-on type)
- Concrete Spreader (Hetzl, Rexomatic & similar types)
- Concrete Vibrator

OPERATING ENGINEERS **Rates Expiration Date :**

Effective Dates:

	07/01/2020		07/01/2021	07/01/2022
Rate	Fringe	Total	Total	Total
51.32	34.50	85.82	88.12	90.37

CLASSIFICATIONS:

- Conveyors - under 125 feet
- Crane Signalman
- Crushing Machine
- Directional Boring Machine
- Ditching Machine - Small (Ditchwitch, Vermeer or similar types)
- Dope Pot - Mechanical (with or without pump)
- Dumpster
- Elevator
- Fireman
- Fork Lift (Economobile, Lull & similar types)
- Front End Loader (1 cu. yd. and over but less than 2 cu. yds.)
- Generator (2 or 3 battery)
- Giraffe Grinder
- Goldhofer/Hydraulic Jacking Trailer
- Grader & Motor Patrols
- Grout Pump
- Gunnite Machine (Excluding nozzle)
- Hammer - Vibratory (in conjunction with generator)
- Heavy Equipment Robotics - Operator/Technician
- Hoist (roof, tugger, aerial platform hoist, house car)
- Hopper
- Hopper Doors (power operated)
- Ladder (motorized)

OPERATING ENGINEERS **Rates Expiration Date :**

Effective Dates:

	07/01/2020		07/01/2021	07/01/2022
Rate	Fringe	Total	Total	Total
51.32	34.50	85.82	88.12	90.37

CLASSIFICATIONS:

Laddervator

Locomotive (Dinky-type)

Maintenance Utility Man

Master Environmental Maintenance Technician

Mechanic

Mixer (Except paving mixers)

Pavement Breaker (truck-mounted or small self-propelled ride-on type)

Pavement Breaker - maintenance of compressor or hydraulic unit

Pipe Bending Machine (power)

Pitch Pump

Plaster Pump (regardless of size)

Post Hole Digger (post pounder, auger)

Rod Bending Machines

Roller (black top)

Scale (power)

Seamen Pulverizing Mixer

Shoulder Widener

Silo

Skimmer Machine (boom type)

Steel Cutting Machine (service & maintenance)

Tamrock Drill

Tractor

Transfer Machines

OPERATING ENGINEERS **Rates Expiration Date :**

Effective Dates:

07/01/2020			07/01/2021	07/01/2022
Rate	Fringe	Total	Total	Total
51.32	34.50	85.82	88.12	90.37

CLASSIFICATIONS:

Tug Captains

Tug Master (Power Boats)

Ultra High Pressure Waterjet Cutting Tool System -
Operator/Maintenance Technician

Vacuum Blasting Machine - Operator/Maintenance Technician

Vibrating Plant (used with unloading)

Welder & Repair Mechanic

Effective Dates:

07/01/2020			07/01/2021	07/01/2022
Rate	Fringe	Total	Total	Total
47.98	34.50	82.48	84.78	87.03

CLASSIFICATIONS:

Assistant Engineer/Oiler

Driller's Helper

Field Engineer - Transit man or Instrument man

Maintenance Apprentice (Deckhand)

Maintenance Apprentice (Oiler)

Mechanic's Helper

Off Road Back Dump

Tire Repair & Maintenance

Effective Dates:

07/01/2020			07/01/2021	07/01/2022
Rate	Fringe	Total	Total	Total
45.40	34.50	79.90	82.20	84.45

CLASSIFICATIONS:

Field Engineer - Rodman or Chainman

TERRITORY
ENTIRE STATE

NEW JERSEY DEPARTMENT OF LABOR AND WORKFORCE DEVELOPMENT
PREVAILING WAGE RATE DETERMINATION

OPERATING ENGINEERS Rates Expiration Date :

Effective Dates:

	07/01/2020		07/01/2021	07/01/2022
Rate	Fringe	Total	Total	Total
55.56	34.50	90.06	92.36	94.61

CLASSIFICATIONS:

Lead Engineer, Foreman Engineer, Safety Engineer (minimum)

OPERATING ENGINEERS **Rates Expiration Date :**

Effective Dates:

	07/01/2020		07/01/2021	07/01/2022
Rate	Fringe	Total	Total	Total
54.82	34.50	89.32	91.62	93.87

CLASSIFICATIONS:

Autograde Pavement Profiler (CMI & similar types)

Autograde Pavement Profiler - Recycle Type (CMI & similar types)

Autograde Placer/Trimmer/Spreader Combination (CMI & similar types)

Autograde Slipform Paver (CMI & similar types)

Backhoe (Excavator)

Central Power Plant

Concrete Paving Machine

Cranes, Derricks, Pile Drivers (all types), under 100 tons with a boom (including jib and/or leads) under 100 ft.

Draglines

Drill, Bauer, AMI and similar types

Drillmaster, Quarrymaster

Drillmaster/Quarrymaster (down-the-hole drill), rotary drill, self-propelled hydraulic drill, self-powered drill

Elevator Grader

Field Engineer-Chief of Party

Front End Loader (5 cu. yards or larger)

Gradall

Grader, Rago

Helicopter Co-Pilot

Helicopter Communications Engineer

Juntann Pile Driver

Locomotive (large)

Mucking Machine

OPERATING ENGINEERS **Rates Expiration Date :**

Effective Dates:

	07/01/2020		07/01/2021	07/01/2022
Rate	Fringe	Total	Total	Total
54.82	34.50	89.32	91.62	93.87

CLASSIFICATIONS:

Pavement & Concrete Breaker (Superhammer & Hoe Ram)

Pile Driver

Prentice Truck

Roadway Surface Grinder

Scooper (loader & shovel)

Shovel (Excavator)

Trackhoe (Excavator)

Tree Chopper with boom

Trenching Machine (cable plow)

Tunnel Boring Machine

Vacuum Truck

OPERATING ENGINEERS **Rates Expiration Date :**

Effective Dates:

	07/01/2020		07/01/2021	07/01/2022
Rate	Fringe	Total	Total	Total
49.69	34.50	84.19	86.49	88.74

CLASSIFICATIONS:

- Chipper
- Compressor (single)
- Concrete Spreader (small type)
- Conveyor Loader (Except elevator graders)
- Engines, Large Diesel (1620 HP) & Staging Pump
- Farm Tractor
- Fertilizing Equipment (operation & maintenance)
- Fine Grade Machine (small type)
- Form Line Grader (small type)
- Front End Loader (under 1 cubic yard)
- Generator (single)
- Grease, Gas, Fuel, & Oil Supply Trucks
- Heaters (Nelson or other type)
- Lights - portable generating light plant
- Mixer, Concrete (small)
- Mulching Equipment (operation & maintenance)
- Power Broom or Sweeper
- Pump (diesel engine & hydraulic - regardless of power)
- Pump (larger than 2 inch suction, including submersible pumps)
- Road Finishing Machine (small type)
- Roller - grade, fill, or stone base
- Seeding Equipment (operation & maintenance)
- Sprinkler & Water Pump Trucks

OPERATING ENGINEERS **Rates Expiration Date :**

Effective Dates:

	07/01/2020		07/01/2021	07/01/2022
Rate	Fringe	Total	Total	Total
49.69	34.50	84.19	86.49	88.74

CLASSIFICATIONS:

Steam Generator or Boiler

Stone Spreader

Tamping Machine (vibrating ride-on type)

Temporary Heating Plant (Nelson or other type, including propane, natural gas, and flow-type units)

Water or Sprinkler Truck

Welding Machine (gas, diesel, or electric convertor, of any type)

Welding System - Multiple (rectifier transformer type)

Wellpoint Systems (including installation by bull gang and maintenance)

Effective Dates:

	07/01/2020		07/01/2021	07/01/2022
Rate	Fringe	Total	Total	Total
56.64	34.50	91.14	93.44	95.69

CLASSIFICATIONS:

Helicopter Pilot/Engineer

Effective Dates:

	07/01/2020		07/01/2021	07/01/2022
Rate	Fringe	Total	Total	Total
61.32	34.50	95.82	98.12	100.37

CLASSIFICATIONS:

Cranes, Derricks, Pile Driver (all types), 100 tons and over and TOWER CRANE with boom (including jib and/or leads) 140 ft. and over

Effective Dates:

	07/01/2020		07/01/2021	07/01/2022
Rate	Fringe	Total	Total	Total
60.32	34.50	94.82	97.12	99.37

CLASSIFICATIONS:

Cranes, Derricks, Pile Driver (all types), 100 tons and over and TOWER CRANE with boom (including jib and/or leads) from 100 ft. to 139 ft.

OPERATING ENGINEERS **Rates Expiration Date :**

Effective Dates:

	07/01/2020		07/01/2021	07/01/2022
Rate	Fringe	Total	Total	Total
56.82	34.50	91.32	93.62	95.87

CLASSIFICATIONS:

Cranes, Derricks, Pile Driver (all types) , under 100 tons with a boom (including jib and/or leads) 140 ft. and over

Effective Dates:

	07/01/2020		07/01/2021	07/01/2022
Rate	Fringe	Total	Total	Total
59.32	34.50	93.82	96.12	98.37

CLASSIFICATIONS:

Cranes, Derricks, Pile Driver (all types), 100 tons and over and TOWER CRANE with a boom (including jib and/or leads) under 100 ft.

Effective Dates:

	07/01/2020		07/01/2021	07/01/2022
Rate	Fringe	Total	Total	Total
55.82	34.50	90.32	92.62	94.87

CLASSIFICATIONS:

Cranes, Derricks, Pile Driver (all types), under 100 tons with a boom (including jib and/or leads) from 100 ft. to 139 ft.

STRUCTURAL STEEL ERECTION **Rates Expiration Date :**

{For apprentice rates refer to "Operating Engineers" apprentice rates in any county rate package}

The regular workday consists of 8 hours, Monday to Friday, between 6:00 AM and 4:30 PM.

SHIFT DIFFERENTIALS:

- Shift work must run for 5 consecutive workdays.
- When 2 shifts are worked, the second shift shall receive an additional 10% of the regular rate inclusive of benefits, per hour.
- When 3 shifts are worked, the second shift shall receive 8 hours pay for 7.5 hours of work, plus an additional 10% of the regular rate inclusive of benefits, per hour. The third shift shall receive 8 hours pay for 7 hours of work, plus an additional 15% of the regular rate inclusive of benefits, per hour.
- When such hours are mandated by the project owner, a shift that starts between 8:00 PM and midnight and ends by 6:00 AM Saturday, or that starts after 8:00 PM on Sunday, provided there are consecutive hours of work within the shift, shall receive an additional 15% of the regular rate, inclusive of benefits.
- On Highway, Road, Street, and Sewer projects irregular shifts starting between 5:00 PM and 12:00 AM may be worked Monday through Friday, and shall receive an additional 15% of the regular rate, inclusive of benefits. When working with other trades that receive a higher irregular shift rate, the Operating Engineer shall also receive the higher irregular shift rate.

OVERTIME:

- Hours in excess of 8 per day, or outside of the regular workday, Monday through Friday, that are not shift work, and all hours on Saturdays shall be paid at time and one-half the regular rate, inclusive of benefits. All hours on Sundays and holidays shall be paid at double the regular rate, inclusive of benefits.
- Four 10-hour days may be worked, Monday through Thursday, at straight time, with all hours on Friday paid at time and one-half the regular rate, inclusive of benefits.

RECOGNIZED HOLIDAYS: New Year's Day, Presidents' Day, Memorial Day, July 4th, Labor Day, Presidential Election Day, Veterans Day, Thanksgiving Day, Christmas Day. Sunday holidays observed the following Monday. When all trades on a particular job site agree, the day after Thanksgiving may be substituted for Veteran's Day.

On hazardous waste removal work or asbestos removal work, on a state or federally designated hazardous waste site, where the operating engineer is in direct contact with hazardous material and when personal protective equipment is required for respiratory, skin, and eye protection, the operating engineer shall receive an additional 20% of the hourly wage, per hour.

Effective Dates:

	07/01/2020		07/01/2021	07/01/2022
Rate	Fringe	Total	Total	Total
58.45	34.50	92.95	95.25	97.50

CLASSIFICATIONS:

Helicopter Co-Pilot & Communications Engineer

TERRITORY
ENTIRE STATE

NEW JERSEY DEPARTMENT OF LABOR AND WORKFORCE DEVELOPMENT
PREVAILING WAGE RATE DETERMINATION

STRUCTURAL STEEL ERECTION Rates Expiration Date :

Effective Dates:

	07/01/2020		07/01/2021	07/01/2022
Rate	Fringe	Total	Total	Total
54.39	34.50	88.89	91.19	93.44

CLASSIFICATIONS:

A-Frame

Cherry Picker -10 tons or less (Over 10 tons use crane rate)

Hoist (all types Except Chicago-boom)

Jack (screw, air hydraulic, power-operated unit or console type, Except hand jack or pile load test type)

Side Boom

Straddle Carrier

STRUCTURAL STEEL ERECTION **Rates Expiration Date :**

Effective Dates:

	07/01/2020		07/01/2021	07/01/2022
Rate	Fringe	Total	Total	Total
51.73	34.50	86.23	88.53	90.78

CLASSIFICATIONS:

- Aerial Platform Used On Hoists
- Apprentice Engineer/Oiler with Compressor or Welding Machine
- Captain (Power Boats)
- Compressor (2 or 3 in battery)
- Concrete Cleaning/Decontamination Machine Operator
- Conveyor or Tugger Hoist
- Directional Boring Machine
- Elevator or House Car
- Fireman
- Forklift
- Generator (2 or 3)
- Heavy Equipment Robotics, Operator/Technician
- Maintenance Utility Man
- Master Environmental Maintenance Technician
- Tug Master (Power Boats)
- Ultra High Pressure Waterjet Cutting Tool System Operator/Maintenance Technician
- Vacuum Blasting Machine Operator/Maintenance Technician
- Welding Machines, Gas or Electric Converters on any type-2 or 3 in battery including diesels

STRUCTURAL STEEL ERECTION **Rates Expiration Date :**

Effective Dates:

07/01/2020			07/01/2021	07/01/2022
Rate	Fringe	Total	Total	Total
50.20	34.50	84.70	87.00	89.25

CLASSIFICATIONS:

Compressor (Single)

Generators

Welding Machines, Gas, Diesel, Or Electric Converters of any type-single

Welding System, Multiple (Rectifier Transformer Type)

Effective Dates:

07/01/2020			07/01/2021	07/01/2022
Rate	Fringe	Total	Total	Total
48.44	34.50	82.94	85.24	87.49

CLASSIFICATIONS:

Assistant Engineer/Oiler

Drillers Helper

Field Engineer - Transit/Instrument Man

Maintenance Apprentice (Deckhand)

Maintenance Apprentice (Oiler)

Off Road Back Dump

Effective Dates:

07/01/2020			07/01/2021	07/01/2022
Rate	Fringe	Total	Total	Total
56.01	34.50	90.51	92.81	95.06

CLASSIFICATIONS:

Lead Engineer, Foreman Engineer, Safety Engineer (Minimum)

Effective Dates:

07/01/2020			07/01/2021	07/01/2022
Rate	Fringe	Total	Total	Total
45.40	34.50	79.90	82.20	84.45

CLASSIFICATIONS:

Field Engineer - Rodman or Chainman

STRUCTURAL STEEL ERECTION **Rates Expiration Date :**

Effective Dates:

07/01/2020			07/01/2021	07/01/2022
Rate	Fringe	Total	Total	Total
55.15	34.50	89.65	91.95	94.20

CLASSIFICATIONS:

Field Engineer-Chief of Party

Vacuum Truck

Effective Dates:

07/01/2020			07/01/2021	07/01/2022
Rate	Fringe	Total	Total	Total
63.34	34.50	97.84	100.14	102.39

CLASSIFICATIONS:

Cranes (all cranes, land or floating with booms, including jib, 140 ft. and over, above ground). Derricks (all derricks, land, floating or Chicago Boom type with booms including jib, 140 ft. and over, above ground), and Pile Drivers (all types) 100 tons and over and Tower Cranes.

Effective Dates:

07/01/2020			07/01/2021	07/01/2022
Rate	Fringe	Total	Total	Total
61.68	34.50	96.18	98.48	100.73

CLASSIFICATIONS:

Cranes (all cranes, land or floating with booms including jib, less than 140 ft. above ground), Derricks (all derricks, land, floating or Chicago Boom type with booms including jib, less than 140 ft. above ground), Pile Drivers (all types), 100 tons and over and Tower Crane.

Effective Dates:

07/01/2020			07/01/2021	07/01/2022
Rate	Fringe	Total	Total	Total
58.84	34.50	93.34	95.64	97.89

CLASSIFICATIONS:

Cranes (all cranes, land or floating with booms including jib, 140 ft. and over, above ground), Derricks (all derricks, land, floating or Chicago Boom type with booms including jib, 140 ft. and over, above ground), Pile Drivers (all types), under 100 tons.

Effective Dates:

07/01/2020			07/01/2021	07/01/2022
Rate	Fringe	Total	Total	Total
57.18	34.50	91.68	93.98	96.23

CLASSIFICATIONS:

Cranes (all cranes, land or floating with booms including jib, less than 140 ft. above ground), Derricks (all derricks, land, floating or Chicago Boom type with booms including jib, less than 140 ft. above ground), Pile Drivers (all types), under 100 tons.

TERRITORY
ENTIRE STATE

NEW JERSEY DEPARTMENT OF LABOR AND WORKFORCE DEVELOPMENT
PREVAILING WAGE RATE DETERMINATION

STRUCTURAL STEEL ERECTION Rates Expiration Date :

Effective Dates:

	07/01/2020		07/01/2021	07/01/2022
Rate	Fringe	Total	Total	Total
58.84	34.50	93.34	95.64	97.89

CLASSIFICATIONS:

Helicopter Pilot & Engineer

TEST BORING PRELIMINARY TO CONSTRUCTION-SOUTH/WEST **Rates Expiration Date :**

THESE RATES APPLY IN THE FOLLOWING COUNTIES ONLY:

Atlantic, Burlington, Camden, Cape May, Cumberland, Gloucester, Hunterdon, Mercer, Monmouth, Ocean, Salem, Sussex, Warren

The regular workday consists of 8 hours, Monday to Friday, between 6:00 AM and 4:30 PM.

SHIFT DIFFERENTIALS:

- Shift work must run for 5 consecutive workdays.
- When 2 shifts are worked, the second shift shall receive an additional 10% of the regular rate inclusive of benefits, per hour.
- When 3 shifts are worked, the second shift shall receive 8 hours pay for 7.5 hours of work, plus an additional 10% of the regular rate inclusive of benefits, per hour. The third shift shall receive 8 hours pay for 7 hours of work, plus an additional 15% of the regular rate inclusive of benefits, per hour.
- When such hours are mandated by the project owner, a shift that starts between 8:00 PM and midnight and ends by 6:00 AM Saturday, or that starts after 8:00 PM on Sunday, provided there are consecutive hours of work within the shift, shall receive an additional 15% of the regular rate, inclusive of benefits.
- On Highway, Road, Street, and Sewer projects irregular shifts starting between 5:00 PM and 12:00 AM may be worked Monday through Friday, and shall receive an additional 15% of the regular rate, inclusive of benefits. When working with other trades that receive a higher irregular shift rate, the Operating Engineer shall also receive the higher irregular shift rate.

OVERTIME:

- Hours in excess of 8 per day, or outside of the regular workday, Monday through Friday, that are not shift work, and all hours on Saturdays shall be paid at time and one-half the regular rate, inclusive of benefits. All hours on Sundays and holidays shall be paid at double the regular rate, inclusive of benefits.
- Four 10-hour days may be worked, Monday through Thursday, at straight time, with all hours on Friday paid at time and one-half the regular rate, inclusive of benefits.

RECOGNIZED HOLIDAYS: New Year's Day, Presidents' Day, Memorial Day, July 4th, Labor Day, Presidential Election Day, Veterans Day, Thanksgiving Day, Christmas Day. Sunday holidays observed the following Monday. When all trades on a particular job site agree, the day after Thanksgiving may be substituted for Veteran's Day.

On hazardous waste removal work or asbestos removal work, on a state or federally designated hazardous waste site, where the operating engineer is in direct contact with hazardous material and when personal protective equipment is required for respiratory, skin, and eye protection, the operating engineer shall receive an additional 20% of the hourly wage, per hour.

Effective Dates:

	07/01/2020		07/01/2021	07/01/2022
Rate	Fringe	Total	Total	Total
54.82	34.50	89.32	91.62	93.87

CLASSIFICATIONS:

Driller

Effective Dates:

	07/01/2020		07/01/2021	07/01/2022
Rate	Fringe	Total	Total	Total
47.98	34.50	82.48	84.78	87.03

CLASSIFICATIONS:

Driller's Helper

FREE AIR TUNNEL JOBS **Rates Expiration Date :**

{For apprentice rates refer to "Heavy & General" apprentice rates in any county rate package}

The regular workday consists of 8 hours, starting at 7:00 AM or 8:00 AM.

SHIFT DIFFERENTIALS:

- Shifts must start at 3:00 PM, 4:00 PM, 12:00 AM, or 1:00 AM, to be considered shift work, except when the project owner mandates special hours of work in the job specifications, in which case those hours may be considered shift work.
- When such hours are mandated by the project owner, a shift that begins before midnight on Friday and ends on Saturday morning, or that begins at or after 8:00 PM on Sunday and ends on Monday morning may be paid at the shift differential rate.
- Shifts shall receive an additional \$3.00 per hour.

OVERTIME:

- Hours in excess of 8 per day, Monday through Friday, or outside of the regular workday that are not shift work, and all hours on Saturdays, shall be paid at time and one-half the hourly rate. All hours on Sundays and holidays shall be paid at double the hourly rate.
- Four 10-hour days may be worked, Monday through Thursday, at straight time, with Friday used as a make-up day for a day lost to inclement weather. If Friday is not a make-up day, all hours on Friday shall be paid at time and one-half the hourly rate.

RECOGNIZED HOLIDAYS: New Year's Day, Presidents' Day, Memorial Day, July 4th, Labor Day, Presidential Election Day, Veterans' Day, Thanksgiving Day, Christmas Day. Sunday holidays observed the following Monday. Veterans Day may be substituted for the day after Thanksgiving. However, in the trading of Veterans Day for the day after Thanksgiving, if overtime is worked on Veterans Day, it shall be paid at double the hourly rate.

Hazardous Waste Work:

- where Level A, B, or C protection is required: + \$3.00/hr
- other Hazardous Waste site: + \$1.00/hr

Effective Dates:

03/01/2020

Rate	Fringe	Total
45.75	32.53	78.28

CLASSIFICATIONS:

Walking Boss & Superintendent

Effective Dates:

03/01/2020

Rate	Fringe	Total
45.45	32.53	77.98

CLASSIFICATIONS:

Heading Foreman, Shaft Foreman, Rod Foreman, Electrician Foreman, Rigging Foreman

FREE AIR TUNNEL JOBS **Rates Expiration Date :**

Effective Dates:

03/01/2020

Rate	Fringe	Total
44.95	32.53	77.48

CLASSIFICATIONS:

Iron Foreman, Caulking Foreman, Form Foreman, Cement Finishing Foreman, Concrete Foreman, Track Foreman, Cleanup Foreman, Grout Foreman

Effective Dates:

03/01/2020

Rate	Fringe	Total
47.45	32.53	79.98

CLASSIFICATIONS:

Blaster

Effective Dates:

03/01/2020

Rate	Fringe	Total
44.40	32.53	76.93

CLASSIFICATIONS:

Top Labor Foreman

Effective Dates:

03/01/2020

Rate	Fringe	Total
44.05	32.53	76.58

CLASSIFICATIONS:

Skilled Men (including Caulker, Powder Carrier, all other skilled men)

Skilled Men (including Miner, Drill Runner, Iron Man, Conveyor Man, Manitenance Man, Safety Miner, Rigger, Block Layer, Cement Finisher, Tod Man)

Effective Dates:

03/01/2020

Rate	Fringe	Total
43.90	32.53	76.43

CLASSIFICATIONS:

Semi-Skilled Men (including Bell or Signal Man Top or Bottom, Form Worker & Mover, Concrete Worker, Shaft Man, Tunnel Laborer, Caulker's Helper, all other semi-skilled)

Semi-Skilled Men (including Miner's Helper, Chuck Tender, Track Man, Nipper, Brake Man, Derail Man, Cable Man, Hose Man, Gravel Man, Form Man)

TERRITORY
ENTIRE STATE

NEW JERSEY DEPARTMENT OF LABOR AND WORKFORCE DEVELOPMENT
PREVAILING WAGE RATE DETERMINATION

FREE AIR TUNNEL JOBS Rates Expiration Date :

Effective Dates:

03/01/2020

Rate	Fringe	Total
43.50	32.53	76.03

CLASSIFICATIONS:

All Others (including Powder Watchman, Change House Attendant, Top Laborer)

DRILL FOR GROUND WATER SUPPLY **Rates Expiration Date :**

The well driller and/or helper may perform all work relative to the construction, finishing, and servicing of wells, pumps and borings for ground water supply. The present methods of well drilling entailing as they do, many diverse job operations calling for drilling, pump discharge, piping, and the operation of various types of related power equipment, shall all be within the job duties and functions of the well driller and/or helper. In the event that an extension of work should occur beyond water well drilling functions, into the field of general construction work, such extension of work would come under the appropriate rates listed elsewhere in this wage determination.

- For Work Hours, Shift Differentials, Overtime Rates, and Recognized Holidays see the "Operating Engineers" section of this wage determination.

Effective Dates:

	07/01/2020		07/01/2021	07/01/2022
Rate	Fringe	Total	Total	Total
53.57	34.50	88.07	90.37	92.62

CLASSIFICATIONS:

Driller

Effective Dates:

	07/01/2020		07/01/2021	07/01/2022
Rate	Fringe	Total	Total	Total
47.33	34.50	81.83	83.53	85.78

CLASSIFICATIONS:

Driller's Helper

OPERATING ENGINEERS MARINE-DREDGING **Rates Expiration Date :**

NOTE: These wage rates only apply to dredging and other marine construction activities occurring in navigable waters and their tributaries.

Boat crews carrying explosive material (dynamite, pourfex, and other similar materials) shall be paid at 120% of the hourly wage rate for hours engaged in handling of said materials. Employees required to possess a Hazardous Material Certification as a condition of employment shall be compensated at 120% of the hourly wage rate.

OVERTIME:

Hours in excess of 40 per week, and all hours on Saturdays and Sundays, shall be paid at time and one-half the hourly rate. All hours on holidays shall be paid at double the hourly rate.

RECOGNIZED HOLIDAYS: New Year's Day, Martin Luther King Day, Good Friday, Memorial Day, July 4th, Labor Day, Veterans' Day, Thanksgiving Day, Christmas Day. Sunday holidays observed the following Monday.

Effective Dates:

10/01/2020

Rate	Fringe	Total
41.42	15.29	56.71

CLASSIFICATIONS:

Lead Dredgerman, Operator, Leverman

Licensed Tug Operator (over 1000 HP)

Effective Dates:

10/01/2020

Rate	Fringe	Total
35.82	14.84	50.66

CLASSIFICATIONS:

Derrick Operator, Spider/Spill Barge Operator

Engineer, Electrician, Chief Welder, Chief Mate

Fill Placer, Operator II

Licensed Boat Operator

Maintenance Engineer

Effective Dates:

10/01/2020

Rate	Fringe	Total
33.72	14.67	48.39

CLASSIFICATIONS:

Certified Welder

OPERATING ENGINEERS MARINE-DREDGING **Rates Expiration Date :**

Effective Dates:

10/01/2020

Rate	Fringe	Total
32.80	14.30	47.10

CLASSIFICATIONS:

Mate, Drag Barge Operator, Steward, Assistant Fill Placer

Welder

Effective Dates:

10/01/2020

Rate	Fringe	Total
31.74	14.21	45.95

CLASSIFICATIONS:

Boat Operator

Effective Dates:

10/01/2020

Rate	Fringe	Total
26.37	13.48	39.85

CLASSIFICATIONS:

Shoreman, Deckhand, Rodman, Scowman

Effective Dates:

10/01/2020

Rate	Fringe	Total
36.91	14.93	51.84

CLASSIFICATIONS:

Crane Operator

MICROSURFACING/SLURRY SEAL **Rates Expiration Date :**

THESE RATES APPLY IN THE FOLLOWING COUNTIES ONLY:

Atlantic, Burlington, Camden, Cape May, Cumberland, Gloucester, Mercer, Ocean, Salem

IN ALL OTHER COUNTIES use the Heavy and General Laborers - North "Slurry Seal Laborer" rates.

SHIFT DIFFERENTIALS:

Any shift starting at 3:30 PM or later shall receive an additional \$0.35/hr

OVERTIME:

Hours in excess of 8 per day or 40 per week shall be paid at time and one-half the hourly rate. All hours on holidays shall be paid at double the hourly rate.

RECOGNIZED HOLIDAYS: New Year's Day, Washington's Birthday, Memorial Day, July 4th, Labor Day, Presidential Election Day, Veterans' Day, Thanksgiving Day, Christmas Day.

Effective Dates:

03/01/2017

Rate	Fringe	Total
36.50	21.27	57.77

CLASSIFICATIONS:

Foreman

Effective Dates:

03/01/2017

Rate	Fringe	Total
33.80	21.27	55.07

CLASSIFICATIONS:

Box man

Effective Dates:

03/01/2017

Rate	Fringe	Total
31.75	21.27	53.02

CLASSIFICATIONS:

Microsurface/Slurry Preparation

Effective Dates:

03/01/2017

Rate	Fringe	Total
31.75	21.27	53.02

CLASSIFICATIONS:

Squeegee man

TERRITORY
ENTIRE STATE

NEW JERSEY DEPARTMENT OF LABOR AND WORKFORCE DEVELOPMENT
PREVAILING WAGE RATE DETERMINATION

MICROSURFACING/SLURRY SEAL Rates Expiration Date :

Effective Dates:

03/01/2017

Rate	Fringe	Total
30.30	21.27	51.57

CLASSIFICATIONS:

Cleaner, Taper

ASPHALT LABORERS - SOUTH **Rates Expiration Date :**

"THESE RATES APPLY IN THE FOLLOWING COUNTIES ONLY: Atlantic, Burlington, Camden, Cape May, Cumberland, Gloucester, Mercer, Ocean, Salem

{For apprentice rates refer to "Laborer - Heavy & General" apprentice rates in any county rate package}

The regular workday consists of 8 hours, starting at 7:00 AM or 8:00 AM.

SHIFT DIFFERENTIALS:

- Shifts must start at 3:00 PM, 4:00 PM, 12:00 AM, or 1:00 AM, to be considered shift work, except when the project owner mandates special hours of work in the job specifications, in which case those hours may be considered shift work.
- When such hours are mandated by the project owner, a shift that begins before midnight on Friday and ends on Saturday morning, or that begins at or after 8:00 PM on Sunday and ends on Monday morning may be paid at the shift differential rate.
- Shifts shall receive an additional \$3.00 per hour.

OVERTIME:

- Hours in excess of 8 per day, Monday through Friday, or outside of the regular workday that are not shift work, and all hours on Saturdays, shall be paid at time and one-half the hourly rate. All hours on Sundays and holidays shall be paid at double the hourly rate.
- Four 10-hour days may be worked, Monday through Thursday, at straight time, with Friday used as a make-up day for a day lost to inclement weather. If Friday is not a make-up day, all hours on Friday shall be paid at time and one-half the hourly rate.

RECOGNIZED HOLIDAYS: New Year's Day, Presidents' Day, Memorial Day, July 4th, Labor Day, Presidential Election Day, Veterans' Day, Thanksgiving Day, Christmas Day. Sunday holidays observed the following Monday. Veterans Day may be substituted for the day after Thanksgiving. However, in the trading of Veterans Day for the day after Thanksgiving, if overtime is worked on Veterans Day, it shall be paid at double the hourly rate.

Hazardous Waste Work:

- where Level A, B, or C protection is required: + \$3.00/hr
- other Hazardous Waste site: + \$1.00/hr

Effective Dates:

03/01/2020

Rate	Fringe	Total
45.25	32.53	77.78

CLASSIFICATIONS:

Paving Foreman

Effective Dates:

03/01/2020

Rate	Fringe	Total
43.80	32.53	76.33

CLASSIFICATIONS:

Head Raker

Effective Dates:

03/01/2020

Rate	Fringe	Total
43.65	32.53	76.18

CLASSIFICATIONS:

Raker, Screedman, Luteman

ASPHALT LABORERS - SOUTH **Rates Expiration Date :**

Effective Dates:

03/01/2020

Rate	Fringe	Total
43.40	32.53	75.93

CLASSIFICATIONS:

Tampers, Smoothers, Kettlemen,
Painters, Shovelers, Roller Boys

Effective Dates:

03/01/2020

Rate	Fringe	Total
43.50	32.53	76.03

CLASSIFICATIONS:

Milling Controller

Effective Dates:

03/01/2020

Rate	Fringe	Total
43.70	32.53	76.23

CLASSIFICATIONS:

Traffic Control Coordinator

TEST BORING PRELIMINARY TO CONSTRUCTION-NORTH **Rates Expiration Date :**

THESE RATES APPLY IN THE FOLLOWING COUNTIES ONLY:
Bergen, Essex, Hudson, Middlesex, Morris, Passaic, Somerset, Union

SHIFT DIFFERENTIAL:

Employees on a shift other than between the hours of 8:00 AM and 5:00 PM shall receive an additional \$2.00 per hour.

OVERTIME:

Hours in excess of 8 per day, Monday through Friday, and all hours on Saturday shall be paid at time and one-half the regular rate. All hours on Sundays and holidays shall be paid at double the regular rate.

RECOGNIZED HOLIDAYS: New Year's Day, Memorial Day, July 4th, Labor Day, Thanksgiving Day, and Christmas Day. Sunday holidays observed the following Monday.

Hazardous Waste Pay (for Levels A, B, and C): an additional 15% of the hourly rate, per hour.

A newly hired Helper with no experience in the industry shall be paid as follows:

- 1st year on the job - 70% of Helper wage rate
- 2nd year on the job - 80% of Helper wage rate
- 3rd year on the job - 90% of Helper wage rate
- All helpers receive full fringe benefit rate.

Effective Dates:

10/18/2020			10/18/2021	10/18/2022
Rate	Fringe	Total	Total	Total
32.92	29.50	62.42	64.17	65.92

CLASSIFICATIONS:

Helper (4th year helper)

Effective Dates:

10/18/2020			10/18/2021	10/18/2022
Rate	Fringe	Total	Total	Total
41.74	29.50	71.24	73.24	75.24

CLASSIFICATIONS:

Driller

Effective Dates:

10/18/2020			10/18/2021	10/18/2022
Rate	Fringe	Total	Total	Total
47.78	29.50	77.28	79.28	81.28

CLASSIFICATIONS:

Foreman

HEAVY & GENERAL LABORERS - NORTH **Rates Expiration Date :**

THESE RATES APPLY IN THE FOLLOWING COUNTIES ONLY:

Bergen, Essex, Hudson, Hunterdon, Middlesex, Monmouth, Morris, Passaic, Somerset, Sussex, Union, Warren

{For apprentice rates refer to "Laborer - Heavy & General" apprentice rates in any county rate package}

The regular workday consists of 8 hours, starting at 7:00 AM or 8:00 AM.

SHIFT DIFFERENTIALS:

- Shifts must start at 3:00 PM, 4:00 PM, 12:00 AM, or 1:00 AM, to be considered shift work, except when the project owner mandates special hours of work in the job specifications, in which case those hours may be considered shift work.
- When such hours are mandated by the project owner, a shift that begins before midnight on Friday and ends on Saturday morning, or that begins at or after 8:00 PM on Sunday and ends on Monday morning may be paid at the shift differential rate.
- Shifts shall receive an additional \$3.00 per hour.

OVERTIME:

- Hours in excess of 8 per day, Monday through Friday, or outside of the regular workday that are not shift work, and all hours on Saturdays, shall be paid at time and one-half the hourly rate. All hours on Sundays and holidays shall be paid at double the hourly rate.
- Four 10-hour days may be worked, Monday through Thursday, at straight time, with Friday used as a make-up day for a day lost to inclement weather. If Friday is not a make-up day, all hours on Friday shall be paid at time and one-half the hourly rate.

RECOGNIZED HOLIDAYS: New Year's Day, Presidents' Day, Memorial Day, July 4th, Labor Day, Presidential Election Day, Veterans' Day, Thanksgiving Day, Christmas Day. Sunday holidays observed the following Monday. Veterans Day may be substituted for the day after Thanksgiving. However, in the trading of Veterans Day for the day after Thanksgiving, if overtime is worked on Veterans Day, it shall be paid at double the hourly rate.

Hazardous Waste Work:

- where Level A, B, or C protection is required: + \$3.00/hr
- other Hazardous Waste site: + \$1.00/hr

Effective Dates:

03/01/2020

Rate	Fringe	Total
43.00	32.53	75.53

CLASSIFICATIONS:

"D" Rate:

basic, landscape, asphalt, slurry seal, or railroad track laborer; utility meter installer; flagman; salamander tender; pitman; dumpman; rakers or tampers on cold patch work; wrappers or coaters of pipe; waterproofer; timberman; wagon drill or drill master helper; powder carrier; magazine tender; signal man; power buggy operator; tree cutter; operator of basic power tools

Effective Dates:

03/01/2020

Rate	Fringe	Total
43.70	32.53	76.23

CLASSIFICATIONS:

"C" Rate:

pipe layer; laser man; conduit or duct line layer; operator of jack hammer, chipping hammer, pavement breaker, concrete cutter, asphalt cutter, sheet hammer, or walk-behind saw cutter; sandblaster; acetylene cutting or burning; wagon drill, directional drill, or hydraulic drill operator; drill master; core driller; traffic control coordinator; asphalt raker or lute man

HEAVY & GENERAL LABORERS - NORTH **Rates Expiration Date :**

Effective Dates:

03/01/2020

Rate	Fringe	Total
43.95	32.53	76.48

CLASSIFICATIONS:

"B" Rate:

concrete finisher; setter of brick or stone pavers; stone cutter; form setter; manhole, catch basin, or inlet builder; asphalt screedman; rammer; hardscaping; gunite nozzle man

Effective Dates:

03/01/2020

Rate	Fringe	Total
47.50	32.53	80.03

CLASSIFICATIONS:

"A" Rate:

blaster

Effective Dates:

03/01/2020

Rate	Fringe	Total
45.25	32.53	77.78

CLASSIFICATIONS:

"FOREMAN" Rate:

labor foreman, asphalt foreman, drill foreman, pipe foreman, grade foreman, finisher foreman, concrete foreman

Effective Dates:

03/01/2020

Rate	Fringe	Total
46.25	32.53	78.78

CLASSIFICATIONS:

"GENERAL FOREMAN" Rate

HEAVY & GENERAL LABORERS - SOUTH **Rates Expiration Date :**

THESE RATES APPLY IN THE FOLLOWING COUNTIES ONLY:

Atlantic, Burlington, Camden, Cape May, Cumberland, Gloucester, Mercer, Ocean, Salem

{For apprentice rates refer to "Laborer - Heavy & General" apprentice rates in any county rate package}

The regular workday consists of 8 hours, starting at 7:00 AM or 8:00 AM.

SHIFT DIFFERENTIALS:

- Shifts must start at 3:00 PM, 4:00 PM, 12:00 AM, or 1:00 AM, to be considered shift work, except when the project owner mandates special hours of work in the job specifications, in which case those hours may be considered shift work.
- When such hours are mandated by the project owner, a shift that begins before midnight on Friday and ends on Saturday morning, or that begins at or after 8:00 PM on Sunday and ends on Monday morning may be paid at the shift differential rate.
- Shifts shall receive an additional \$3.00 per hour.

OVERTIME:

- Hours in excess of 8 per day, Monday through Friday, or outside of the regular workday that are not shift work, and all hours on Saturdays, shall be paid at time and one-half the hourly rate. All hours on Sundays and holidays shall be paid at double the hourly rate.
- Four 10-hour days may be worked, Monday through Thursday, at straight time, with Friday used as a make-up day for a day lost to inclement weather. If Friday is not a make-up day, all hours on Friday shall be paid at time and one-half the hourly rate.

RECOGNIZED HOLIDAYS: New Year's Day, Presidents' Day, Memorial Day, July 4th, Labor Day, Presidential Election Day, Veterans' Day, Thanksgiving Day, Christmas Day. Sunday holidays observed the following Monday. Veterans Day may be substituted for the day after Thanksgiving. However, in the trading of Veterans Day for the day after Thanksgiving, if overtime is worked on Veterans Day, it shall be paid at double the hourly rate.

Hazardous Waste Work:

- where Level A, B, or C protection is required: + \$3.00/hr
- other Hazardous Waste site: + \$1.00/hr

Effective Dates:

03/01/2020

Rate	Fringe	Total
43.00	32.53	75.53

CLASSIFICATIONS:

basic, landscape, or railroad track laborer; utility meter installer; flagman; salamander tender; pitman; dumpman; rakers or tampers on cold patch work; wrappers or coaters of pipe; waterproofers; tree cutter, timberman

Effective Dates:

03/01/2020

Rate	Fringe	Total
43.00	32.53	75.53

CLASSIFICATIONS:

wagon drill or drill master helper; powder carrier; magazine tender; signal man

HEAVY & GENERAL LABORERS - SOUTH **Rates Expiration Date :**

Effective Dates:

03/01/2020

Rate	Fringe	Total
43.70	32.53	76.23

CLASSIFICATIONS:

pipe layer; laser man; conduit or duct line layer; operator of jack hammer, chipping hammer, pavement breaker, concrete cutter, asphalt cutter, sheet hammer, or walk-behind saw cutter; sandblaster; acetylene cutting or burning

Effective Dates:

03/01/2020

Rate	Fringe	Total
43.70	32.53	76.23

CLASSIFICATIONS:

wagon or directional drill operator; drill master

Effective Dates:

03/01/2020

Rate	Fringe	Total
47.50	32.53	80.03

CLASSIFICATIONS:

blaster

Effective Dates:

03/01/2020

Rate	Fringe	Total
45.25	32.53	77.78

CLASSIFICATIONS:

labor foreman, drill foreman, pipe foreman, grade foreman, finisher foreman, concrete foreman

Effective Dates:

03/01/2020

Rate	Fringe	Total
46.25	32.53	78.78

CLASSIFICATIONS:

general foreman

TERRITORY
ENTIRE STATE

NEW JERSEY DEPARTMENT OF LABOR AND WORKFORCE DEVELOPMENT
PREVAILING WAGE RATE DETERMINATION

HEAVY & GENERAL LABORERS - SOUTH Rates Expiration Date :

Effective Dates:

03/01/2020

Rate	Fringe	Total
43.95	32.53	76.48

CLASSIFICATIONS:

concrete finisher; setter of brick or stone pavers; stone cutter; form setter; manhole, catch basin, or inlet builder; rammer; gunite nozzle man

PIPELINE - MAINLINE TRANSMISSION **Rates Expiration Date :**

These rates apply to the following: welding on Transportation Mainline pipe lines (cross-country pipe lines, or any segments thereof, transporting coal, gas, oil, water or other transportable materials, vapors or liquids, including portions of such pipe lines within private property boundaries up to the final metering station or connection - the point where a valve, consumer connection, or town border station divides mainline transmission lines or higher pressure lateral and branch lines from lower pressure distribution systems).

PER DIEM PAYMENT:

In addition to the total wage rate paid for each craft, the following per diem (per day) amounts must also be paid - Pipeline Journeyman: \$80.50; Pipeline Journeyman Welder: \$140.50; and Pipeline Helper: \$64.50. Note: in order to receive the per diem payment an employee must work a minimum of 8 hours in a 24 hour period.

NOTES:

- Journeymen employed as "stringer bead" welders and journeymen who are regularly employed as "hot-pass" welders shall receive \$1.00 per hour more than other journeymen.
- Welders running "stringer bead" or "hot-pass" on "cutouts" or "tie-ins" on a production basis shall be paid \$1.00 per hour above the journeymen rate.
- Whenever a welder helper is employed using a power buffer or power grinder immediately behind the stringer bead and/or hot-pass welders, and the pipe gang is set on a production basis, the helper shall be paid \$2.00 per hour above the helper rate.
- If back welding is performed inside a pipe under either or both of the following conditions, the welder engaged in the welding will receive \$3.00 per hour above the regular rate for the job only for the days on which such back welding is performed:
 - The employer elects, as a regular procedure, to back weld each line-up. This condition is not intended to apply to occasional back welding performed by the pipe gang to repair a bead, to rectify a "high-lo" condition or wall thickness, etc.
 - A welder is required to back weld a completed weld behind the firing line.
- If the welder helper is required to go inside the pipe for the purpose of brushing, buffing and grinding the weld, they shall receive a wage rate \$1.00 per hour above the regular helper rate for the days involved.
- Welders working on "hot work" shall be paid \$2.00 per hour above the regular rate for each day engaged in such work. "Hot work" is defined as work on lines in service where there is the danger of fire or explosion.

The regular workday shall be 8 hours, between 8:00 AM and 4:30 PM.

OVERTIME:

Hours in excess of 8 per day, and all hours on Sundays shall be paid at time and one-half the regular rate, inclusive of benefits. All hours on holidays shall be paid at double the regular rate, inclusive of benefits.

RECOGNIZED HOLIDAYS: New Year's Day, July 4th, Labor Day, Thanksgiving Day, and Christmas Day. Sunday holidays observed the following Monday.

Effective Dates:

06/09/2020

Rate	Fringe	Total
54.58	32.80	87.38

CLASSIFICATIONS:

Pipeline Journeyman Welder

TERRITORY
ENTIRE STATE

NEW JERSEY DEPARTMENT OF LABOR AND WORKFORCE DEVELOPMENT
PREVAILING WAGE RATE DETERMINATION

PIPELINE - MAINLINE TRANSMISSION Rates Expiration Date :

Effective Dates:

06/09/2020

Rate	Fringe	Total
54.58	32.80	87.38

CLASSIFICATIONS:

Pipeline Journeyman

Effective Dates:

06/09/2020

Rate	Fringe	Total
33.27	22.42	55.69

CLASSIFICATIONS:

Pipeline Helper

PIPELINE - GAS DISTRIBUTION **Rates Expiration Date :**

These rates apply to the following: welding on gas line distribution systems (that portion of the gas distribution system placed in streets, roads, subways, tunnels, viaducts, highways and easements which serves the users of gas).

SHIFT DIFFERENTIALS:

An "irregular" shift may start any time from 5:00 PM to 12:00 AM, Monday through Friday, and shall receive an additional 15% of the regular rate per hour, inclusive of benefits.

OVERTIME:

Hours in excess of forty per week, and all hours on Saturdays shall be paid at time and one-half the regular rate, inclusive of benefits. All hours on Sundays and holidays shall be paid at double the regular rate, inclusive of benefits.

RECOGNIZED HOLIDAYS: New Year's Day, Memorial Day, July 4th, Labor Day, Thanksgiving Day, and Christmas Day. Sunday holidays observed the following Monday.

Effective Dates:

11/08/2019

Rate	Fringe	Total
60.00	26.23	86.23

CLASSIFICATIONS:

Pipeline Journeyman Welder

Effective Dates:

11/08/2019

Rate	Fringe	Total
60.00	26.23	86.23

CLASSIFICATIONS:

Pipeline Journeyman

Effective Dates:

11/08/2019

Rate	Fringe	Total
38.46	19.21	57.67

CLASSIFICATIONS:

Pipeline Helper

ASPHALT LABORERS- NORTH **Rates Expiration Date :**

THESE RATES APPLY IN THE FOLLOWING COUNTIES ONLY:

Bergen, Essex, Hudson, Hunterdon, Middlesex, Monmouth, Morris, Passaic, Somerset, Sussex, Union, Warren

{For apprentice rates refer to "Laborer - Heavy & General" apprentice rates in any county rate package}

The regular workday consists of 8 hours, starting at 7:00 AM or 8:00 AM.

SHIFT DIFFERENTIALS:

- Shifts must start at 3:00 PM, 4:00 PM, 12:00 AM, or 1:00 AM, to be considered shift work, except when the project owner mandates special hours of work in the job specifications, in which case those hours may be considered shift work.
- When such hours are mandated by the project owner, a shift that begins before midnight on Friday and ends on Saturday morning, or that begins at or after 8:00 PM on Sunday and ends on Monday morning may be paid at the shift differential rate.
- Shifts shall receive an additional \$3.00 per hour.

OVERTIME:

- Hours in excess of 8 per day, Monday through Friday, or outside of the regular workday that are not shift work, and all hours on Saturdays, shall be paid at time and one-half the hourly rate. All hours on Sundays and holidays shall be paid at double the hourly rate.
- Four 10-hour days may be worked, Monday through Thursday, at straight time, with Friday used as a make-up day for a day lost to inclement weather. If Friday is not a make-up day, all hours on Friday shall be paid at time and one-half the hourly rate.

RECOGNIZED HOLIDAYS: New Year's Day, Presidents' Day, Memorial Day, July 4th, Labor Day, Presidential Election Day, Veterans' Day, Thanksgiving Day, Christmas Day. Sunday holidays observed the following Monday. Veterans Day may be substituted for the day after Thanksgiving. However, in the trading of Veterans Day for the day after Thanksgiving, if overtime is worked on Veterans Day, it shall be paid at double the hourly rate.

Hazardous Waste Work:

- where Level A, B, or C protection is required: + \$3.00/hr
- other Hazardous Waste site: + \$1.00/hr

Effective Dates:

03/01/2020

Rate	Fringe	Total
45.25	32.53	77.78

CLASSIFICATIONS:

Asphalt Foreman

Effective Dates:

03/01/2020

Rate	Fringe	Total
43.95	32.53	76.48

CLASSIFICATIONS:

Asphalt Screedman

Effective Dates:

03/01/2020

Rate	Fringe	Total
43.70	32.53	76.23

CLASSIFICATIONS:

Asphalt Raker or Lute Man

TERRITORY
ENTIRE STATE

NEW JERSEY DEPARTMENT OF LABOR AND WORKFORCE DEVELOPMENT
PREVAILING WAGE RATE DETERMINATION

ASPHALT LABORERS- NORTH Rates Expiration Date :

Effective Dates:

03/01/2020

Rate	Fringe	Total
43.00	32.53	75.53

CLASSIFICATIONS:

Asphalt Laborer

ELECTRICIAN- UTILITY WORK (NORTH) **Rates Expiration Date :**

Electrician-Utility Work (North)

(For apprentice rates refer to Electrician-Utility Work (North) in any county rate package).

These rates apply to work contracted for by the following utility companies:

Public Service Electric & Gas Co. of NJ, GPU Energy, Borough of Madison Electric Department, Sussex Rural Electric Cooperative, Rockland Utilities, and Butler Municipal Electric Co.

These rates do not apply to work on substations or switching stations.

For Utility work contracted for by a utility company other than those listed above or those listed under "Electrician-Utility Work (South)", see the "Outside Commercial Rates" for the county in which the jobsite is located.

* FOR OUTSIDE COMMERCIAL RATES PLEASE SEE COUNTY RATES

The regular workday is 8 hours, between 6:00 AM and 6:00 PM.

FOR EMERGENCY WORK ONLY: (emergency work is defined as work caused by storm, catastrophe, act of god, and circumstances beyond the control of the employer)-all hours of work shall be paid at double the hourly rate.

SHIFT DIFFERENTIALS:

Shift work must run for a minimum of 5 consecutive workdays.

2nd shift (between the hours of 4:30 PM and 1:00 AM): 8 hours of work + 17.3% of the regular rate, inclusive of benefits.

3rd shift (between the hours of 12:30 AM and 9:00 AM): 8 hours of work + 31.4% of the regular rate per hour, inclusive of benefits.

OVERTIME:

Hours in excess of 8 per day, or before or after the regular workday Monday through Friday, that is not shift work, and all hours on Saturday shall be paid at time and one-half the regular rate, inclusive of benefits. All hours on Sundays and holidays shall be paid at double the hourly rate, inclusive of benefits.

Four 10-hour days may worked, at straight time, between 7:00 AM and 6:30 PM, Monday through Thursday.

RECOGNIZED HOLIDAYS:

New Year's Day, Presidents' Day, Memorial Day, July 4th, Labor Day, Presidential Election Day, Veterans' Day, Thanksgiving Day and Christmas Day, or day on which they are legally observed.

Effective Dates:

	12/30/2019		11/29/2020
Rate	Fringe	Total	Total
55.89	38.56	94.45	96.84

CLASSIFICATIONS:

Chief Lineman

Effective Dates:

	12/30/2019		11/29/2020
Rate	Fringe	Total	Total
52.73	36.38	89.11	91.36

CLASSIFICATIONS:

Journeyman Lineman

ELECTRICIAN- UTILITY WORK (NORTH) **Rates Expiration Date :**

Effective Dates:

12/30/2019			11/29/2020
Rate	Fringe	Total	Total
52.73	36.38	89.11	91.36

CLASSIFICATIONS:

Special License Operator

Effective Dates:

12/30/2019			11/29/2020
Rate	Fringe	Total	Total
52.20	36.02	88.22	90.44

CLASSIFICATIONS:

Transit Man

Effective Dates:

12/30/2019			11/29/2020
Rate	Fringe	Total	Total
50.62	34.91	85.53	87.70

CLASSIFICATIONS:

Line Equipment Operator

Effective Dates:

12/30/2019			11/29/2020
Rate	Fringe	Total	Total
44.29	30.55	74.84	76.73

CLASSIFICATIONS:

Dynamite Man

Effective Dates:

12/30/2019			11/29/2020
Rate	Fringe	Total	Total
65.91	45.47	111.38	114.19

CLASSIFICATIONS:

General Foreman

Effective Dates:

12/30/2019			11/29/2020
Rate	Fringe	Total	Total
60.64	41.83	102.47	105.05

CLASSIFICATIONS:

Assistant General Foreman

ELECTRICIAN- UTILITY WORK (NORTH) **Rates Expiration Date :**

Effective Dates:

12/30/2019			11/29/2020
Rate	Fringe	Total	Total
59.06	40.73	99.79	102.32

CLASSIFICATIONS:

Line Foreman

Effective Dates:

12/30/2019			11/29/2020
Rate	Fringe	Total	Total
42.71	29.46	72.17	73.99

CLASSIFICATIONS:

Street Light Mechanical Leader

Effective Dates:

12/30/2019			11/29/2020
Rate	Fringe	Total	Total
40.60	28.02	68.62	70.34

CLASSIFICATIONS:

Groundman Winch Operator

Effective Dates:

12/30/2019			11/29/2020
Rate	Fringe	Total	Total
40.60	28.02	68.62	70.34

CLASSIFICATIONS:

Groundman Truck Operator

Effective Dates:

12/30/2019			11/29/2020
Rate	Fringe	Total	Total
40.07	27.64	67.71	69.43

CLASSIFICATIONS:

Street Light Mechanic

Effective Dates:

12/30/2019			11/29/2020
Rate	Fringe	Total	Total
40.07	27.64	67.71	69.43

CLASSIFICATIONS:

Line Equipment Mechanic

TERRITORY
ENTIRE STATE

NEW JERSEY DEPARTMENT OF LABOR AND WORKFORCE DEVELOPMENT
PREVAILING WAGE RATE DETERMINATION

ELECTRICIAN- UTILITY WORK (NORTH) Rates Expiration Date :

Effective Dates:

12/30/2019			11/29/2020
Rate	Fringe	Total	Total
34.27	23.64	57.91	59.38

CLASSIFICATIONS:

Groundman 2nd Year

Effective Dates:

12/30/2019			11/29/2020
Rate	Fringe	Total	Total
31.64	21.83	53.47	54.80

CLASSIFICATIONS:

Groundman 1st Year

Effective Dates:

12/30/2019			11/29/2020
Rate	Fringe	Total	Total
52.20	36.02	88.22	90.44

CLASSIFICATIONS:

Line Equipment Foreman

ELECTRICIAN- UTILITY WORK (SOUTH) **Rates Expiration Date :**

Electrician-Utility Work (South)

(For apprentice rates refer to Electrician-Utility Work (South) in any county rate package).

These rates apply to work contracted for by the following utility company:

Atlantic City Electric.

These rates do not apply to work on substations or switching stations.

For utility work contracted for by a utility company other than the one listed above or those listed under "Electrician-Utility Work (North)", see the "Outside Commercial Rates" for the county in which the jobsite is located.

* FOR OUTSIDE COMMERCIAL RATES PLEASE SEE COUNTY RATES

The regular workday is 8 hours, between 7:00 AM and 4:30 PM.

FOR EMERGENCY WORK ONLY: (emergency work is defined as work caused by storm, catastrophe, act of god, and circumstances beyond the control of the employer)- all hours of work shall be paid at double the hourly rate.

SHIFT DIFFERENTIALS:

Shift work must run for a minimum of 5 consecutive workdays.

When two (2) or three (3) shifts are worked the following shall apply:

1st shift (between the hours of 8:00 AM and 4:30 PM)

2nd shift (between the hours of 4:30 PM and 12:30 AM): 8 hours of work + 10% of the regular rate of pay for 7.5 hours worked.

3rd shift (between the hours of 12:30 AM and 8:00 AM): 8 hours of work + 15% of the regular rate of pay for 7 hours worked.

OVERTIME:

Hours in excess of 8 per day, or before or after the regular workday Monday through Friday, that is not shift work, and all hours on Saturday shall be paid at time and one-half the regular rate. All hours on Sundays and Holidays shall be paid double the hourly rate.

Four 10-hour days may be worked, at straight time, between 6:00 AM and 6:00 PM, Monday through Thursday with Friday used as a make-up day.

RECOGNIZED HOLIDAYS:

New Year's Day, Memorial Day, July 4th, Labor Day, Veterans' Day, Thanksgiving Day and Christmas Day or on days celebrated.

WORKING RULES:

There shall be a Foreman in charge of each work crew. No crews are to exceed twelve (12) men, including Foremen.

There shall be a General Foreman designated for transmission work when three (3) or more crews are on the same job and for distribution work where there are more than twenty (20) employees on site.

A small job crew shall consist of five (5) or less employees, one (1) of the Journeyman Linemen in the crew shall be designated as a Small Job Foreman.

Work performed from ladders and/or mechanical lift equipment shall be the work of Linemen and/or Apprentices.

On new construction, fitting and framing poles, towers or structures may be done by Journeymen and/or Apprentices. Groundmen may assist, but may not perform any work which would be performed by Linemen if assembled in the air.

There shall be a Journeyman Lineman in each pole setting, erection, grounding, wire and cable-pulling crew of more than three (3) men.

Effective Dates:

12/01/2019

Rate	Fringe	Total
62.11	49.53	111.64

CLASSIFICATIONS:

General Foreman

ELECTRICIAN- UTILITY WORK (SOUTH) **Rates Expiration Date :**

Effective Dates:

12/01/2019

Rate	Fringe	Total
55.31	45.49	100.80

CLASSIFICATIONS:

Foreman

Effective Dates:

12/01/2019

Rate	Fringe	Total
52.40	43.78	96.18

CLASSIFICATIONS:

Small Job Foreman

Effective Dates:

12/01/2019

Rate	Fringe	Total
48.52	41.48	90.00

CLASSIFICATIONS:

Heavy Equipment Operator

Effective Dates:

12/01/2019

Rate	Fringe	Total
48.52	41.48	90.00

CLASSIFICATIONS:

Cable Splicer

Effective Dates:

12/01/2019

Rate	Fringe	Total
48.52	41.48	90.00

CLASSIFICATIONS:

Journeyman Lineman

Effective Dates:

12/01/2019

Rate	Fringe	Total
48.52	41.48	90.00

CLASSIFICATIONS:

Journeyman Welder

ELECTRICIAN- UTILITY WORK (SOUTH) **Rates Expiration Date :**

Effective Dates:

12/01/2019

Rate	Fringe	Total
48.52	41.48	90.00

CLASSIFICATIONS:

Journeyman Painter

Effective Dates:

12/01/2019

Rate	Fringe	Total
38.82	35.73	74.55

CLASSIFICATIONS:

Light Equipment Operator

Effective Dates:

12/01/2019

Rate	Fringe	Total
33.96	32.86	66.82

CLASSIFICATIONS:

Groundman Truck Driver

Effective Dates:

12/01/2019

Rate	Fringe	Total
31.54	31.44	62.98

CLASSIFICATIONS:

Groundman 3rd Year

Effective Dates:

12/01/2019

Rate	Fringe	Total
29.11	30.01	59.12

CLASSIFICATIONS:

Groundman 2nd Year

Effective Dates:

12/01/2019

Rate	Fringe	Total
26.69	28.57	55.26

CLASSIFICATIONS:

Groundman 1st Year

TERRITORY
ENTIRE STATE

NEW JERSEY DEPARTMENT OF LABOR AND WORKFORCE DEVELOPMENT
PREVAILING WAGE RATE DETERMINATION

ELECTRICIAN- UTILITY WORK (SOUTH) Rates Expiration Date :

Effective Dates:

12/01/2019

Rate	Fringe	Total
21.35	25.41	46.76

CLASSIFICATIONS:

Flagman

HEAVY & GENERAL LABORERS- NEW TRANS HUDSON TUNNELS **Rates Expiration Date :**

****THESE RATES APPLY TO CONSTRUCTION ON NEW TRANS HUDSON TUNNELS ONLY****

{For apprentice rates refer to "Laborer - Heavy & General" apprentice rates in any county rate package}

The regular workday consists of 8 hours, starting at 7:00 AM or 8:00 AM.

SHIFT DIFFERENTIALS:

- Shifts must start at 3:00 PM, 4:00 PM, 12:00 AM, or 1:00 AM, to be considered shift work, except when the project owner mandates special hours of work in the job specifications, in which case those hours may be considered shift work.
- When such hours are mandated by the project owner, a shift that begins before midnight on Friday and ends on Saturday morning, or that begins at or after 8:00 PM on Sunday and ends on Monday morning may be paid at the shift differential rate.
- Shifts shall receive an additional \$3.00 per hour.

OVERTIME:

- Hours in excess of 8 per day, Monday through Friday, or outside of the regular workday that are not shift work, and all hours on Saturdays, shall be paid at time and one-half the hourly rate. All hours on Sundays and holidays shall be paid at double the hourly rate.
- Four 10-hour days may be worked, Monday through Thursday, at straight time, with Friday used as a make-up day for a day lost to inclement weather. If Friday is not a make-up day, all hours on Friday shall be paid at time and one-half the hourly rate.

RECOGNIZED HOLIDAYS: New Year's Day, Presidents' Day, Memorial Day, July 4th, Labor Day, Presidential Election Day, Veterans' Day, Thanksgiving Day, Christmas Day. Sunday holidays observed the following Monday. Veterans Day may be substituted for the day after Thanksgiving. However, in the trading of Veterans Day for the day after Thanksgiving, if overtime is worked on Veterans Day, it shall be paid at double the hourly rate.

Hazardous Waste Work:

- where Level A, B, or C protection is required: + \$3.00/hr
- other Hazardous Waste site: + \$1.00/hr

Effective Dates:

03/01/2020

Rate	Fringe	Total
68.63	32.53	101.16

CLASSIFICATIONS:

Walking Boss & Superintendent

Effective Dates:

03/01/2020

Rate	Fringe	Total
68.18	32.53	100.71

CLASSIFICATIONS:

Heading Foreman, Shaft Foreman, Rod Foreman, Electrical Foreman, Rigging Foreman

HEAVY & GENERAL LABORERS- NEW TRANS HUDSON TUNNELS **Rates Expiration Date :**

Effective Dates:

03/01/2020

Rate	Fringe	Total
67.43	32.53	99.96

CLASSIFICATIONS:

Iron Foreman, Caulking Foreman, Form Foreman, Cement Finishing Foreman, Concrete Foreman, Track Foreman, Clean-up Foreman, Grout Foreman

Effective Dates:

03/01/2020

Rate	Fringe	Total
71.18	32.53	103.71

CLASSIFICATIONS:

Blaster

Effective Dates:

03/01/2020

Rate	Fringe	Total
66.60	32.53	99.13

CLASSIFICATIONS:

Top Labor Foreman

Effective Dates:

03/01/2020

Rate	Fringe	Total
66.08	32.53	98.61

CLASSIFICATIONS:

Skilled Men (including Caulker, Powder Carrier, all other skilled men)

Skilled Men (including Miner, Drill Runner, Iron Man, Conveyor Man, Maintenance Man, Safety Miner, Rigger, Block Layer, Cement Finisher, Rod Man)

Effective Dates:

03/01/2020

Rate	Fringe	Total
65.85	32.53	98.38

CLASSIFICATIONS:

Semi-Skilled Men (including Bell or Signal Man top or bottom, Form Worker & Mover, Concrete Worker, Shaft Man, Tunnel Laborer, Caulker's Helper, all other semi-skilled)

Semi-Skilled Men (including Miner's Helper, Chuck Tender, Track Man, Nipper, Brake Man, Derail Man, Cable Man, Hose Man, Gravel Man, Form Man)

TERRITORY
ENTIRE STATE

NEW JERSEY DEPARTMENT OF LABOR AND WORKFORCE DEVELOPMENT
PREVAILING WAGE RATE DETERMINATION

HEAVY & GENERAL LABORERS- NEW TRANS HUDSON TUNNELS Rates Expiration Date :

Effective Dates:

03/01/2020

Rate	Fringe	Total
65.25	32.53	97.78

CLASSIFICATIONS:

All others (including Powder Watchman, Change House Attendant, Top Laborer, Job Steward)

From: no-reply@dol.nj.gov
To: [MaryAnn Brennan](#)
Subject: Prevailing Wage Rate Determination Confirmation No. 75318
Date: Thursday, October 22, 2020 3:03:35 PM

***** CAUTION *****

This message came from an EXTERNAL address. DO NOT click on links or attachments unless you know the sender and the content is safe. If suspicious forward the message to pcsupport@ucnj.org

Thank you for requesting an Official Prevailing Wage Rate Determination from the New Jersey Department of Labor and Workforce Development, Division of Wage and Hour Compliance.

The official prevailing wage rate determination details are displayed below. You may also view these details at any time by visiting [WageRatesConf.html](#) and entering the confirmation number.

Confirmation No.: 75318 **Date of Determination:** 10/22/2020 15:03:30

Below is the list of attachments included in the official wage rate determination:	
UNION	294095704-union-10-20-20.pdf
STATE WIDE RATES	294095748-statewide-10-20-20.pdf
PWConfirmation.PDF	PWConfirmation.pdf
Public Body Awarding the Contract	
Name: County of Union FEIN: XXXXX2481	
Street: 2325 South ave	
City: Scotch Plains State & Zip: NJ 07023	
Project No.:	
Requesting Officer	
First Name: Maryann	
Last Name: Brennan	
Title:	
Company Name: County of Union	
Phone No.: 908-789-3652 Ext. Email: maryann.brennan@ucnj.org	
Street: 2325 South ave	
City: Scotch Plains State & Zip: NJ 07023	

Contractor Who is Being Awarded the Contract
Company Name: TBD FEIN: Contact First Name: Contact Last Name: Street: City: State & Zip: NJ Contract Amount: \$
Location Where Work Will Be Performed
Street: City: Kenilworth
Description of Work: Intersection Improvement

If any of the links/attachments are not working, please forward this email to PWRIssues@dol.nj.gov and explain which of the links/attachments are not working. Please note that this email address is for online technical issues only; any law or wage rate questions sent to this email address cannot be answered and will be deleted.

For additional information about Prevailing Wage Rate Determinations, please go to [Prevailing Wage Rates on Construction-Related Public Works Projects.](#)

Sincerely,

NJ Department of Labor and Workforce Development
Division of Wage and Hour Compliance
Public Contracts Section
PO Box 389
Trenton, NJ 08625-0389

Tel. (609) 292-2259
Fax (609) 695-1174

ADVISORY: No contractor shall bid on any contract for public work as defined in section 2 of P.L.1963, c. 150 (C.34:11-56.26) unless the contractor is registered pursuant to this act. No

contractor shall list a subcontractor in a bid proposal for the contract unless the subcontractor is registered pursuant to P.L.1999, c.238 (C.34:11-56.48 et seq.) at the time the bid is made. No contractor or subcontractor, including a subcontractor not listed in the bid proposal, shall engage in the performance of any public work subject to the contract, unless the contractor or subcontractor is registered pursuant to that act. To verify a contractor/subcontractor's registration, go online at www.nj.gov/labor (click on Wage & Hour) or go directly [List of Registered Public Works Contractors](#).



State of New Jersey

DEPARTMENT OF LABOR AND WORKFORCE DEVELOPMENT
PO BOX 389
TRENTON, NEW JERSEY 08625-0389

October 26, 2020

LISTED CONTRACTORS AND SUBCONTRACTORS

PURSUANT TO N.J.S.A 34:11-56.37 AND 34:11-56.38 OF THE PREVAILING WAGE ACT

NO PUBLIC WORKS CONTRACT MAY BE AWARDED TO ANY OF THE FOLLOWING CONTRACTORS AND SUBCONTRACTORS OR TO ANY FIRM, CORPORATION OR PARTNERSHIP IN WHICH THEY HAVE AN INTEREST UNTIL THE EXPIRATION DATE GIVEN.

<u>CONTRACTORS AND SUBCONTRACTORS</u>	<u>ADDRESS</u>	<u>EXPIRATION DATE</u>
A P Roofing & Siding, LLC	259 Main Street, Chester, NJ 07930	12/20/2020
A. Perin Roofing & Siding, LLC Adelino Perin, President	12 Valley Place, Chester, NJ 07930	
A Z Construction of NJ Inc./ Alex Drywall	1038 Park Ave, Apt 11, Plainfield, NJ 07060	09/28/2023
A Z Construction of NJ Inc. Alex Zuniga, Owner	1038 Park Ave, #11, Plainfield, NJ 07060	
All American Demolition & Dismantling, LLC	9 Silver Spring Court, East Hanover, NJ 07936-2529	08/05/2021
All Merican Demolition & Dismantling LLC Theodore Fiore Jr, Owner	9 Silver Spring Court, East Hanover, NJ 07936-2529	
Alvarez Painting, LLC	907 Madison Ave., Apt 1L, Elizabeth, NJ 07201	08/20/2021
Elvin Alvarez, Owner	907 Madison Avenue, Elizabeth, NJ 07201	
ANV Transport	1546 Wooded Acres Drive, Stroudsburg, PA 18360	12/18/2021
Adam Fernando, Owner	1546 Wooded Acres Drive, Stroudsburg, PA 18360	
Applied Construction Services, Inc.	710 Trainer St, Chester, PA 19013	10/12/2023
John Stephen Rippert, CEO	710 Trainer Street, Chester, PA 19013	
Aventus Construction Inc.	210 River Street Suite 21, Hackensack, NJ 07601	07/28/2022
Danko Tomasevic, Vice-President	24 Albert Street, Garfield, NJ 07026-2130	
Stanislav Tolstunov, President	185 Prospect Avenue,, Unit 51, Hackensack, NJ 07601	
Polina Tolstunov, President	20 Ave. at Port Imperial, West New York, NY 07093	
Barbos HVAC, LLC	3 - C Brynwood Gardens, Apt 18, Old Bridge, NJ 08857	08/01/2021
Ihor Shcherbii, Owner	3-C Brynwood gardens, Apt 18, Old Bridge, NJ 08857	
Beach Coast Builders LLC	698 Northstream Dr., Toms River, NJ 08753	02/24/2022
TJN Development LLC Timothy J. Noon, Owner	698 Northstream Drive, Toms River, NJ 08753	
BRASUSA CONSTRUCTION INC	3 Laila Ct, Monroe, NJ 08831-0883	04/17/2022
Fabricio Queiroz, President	3 Laila Ct, Monroe, NJ 08831-0883	
Helayne Queiroz, Vice-President	3 Laila Ct, Monroe, NJ 08831-0883	
Bravo General Contractors Inc	72 Charlotte Drive, Churchville, PA 18966	11/20/2020
John Hunsecker, Vice-President	72 Charlotte Drive, Churchville, PA 18966	

CONTRACTORS AND SUBCONTRACTORS**ADDRESS****EXPIRATION DATE**

Brickhouse Construction Inc BRICKHOUSE CONSTRUCTION INC Sonia Burke, President	21 Pine Street, Suite 115, Rockaway, NJ 07866-0786 3 Brandywine Court, Randolph, NJ 07869-0786	09/11/2022
Building Construction Management LLC Joseph O'Brien, Owner / Officer	110 E 20th Ave., North Wildwood, NJ 08260 171 Cedar Lane West, Cape May Court House, NJ 08210	10/18/2023
C C & C General Contractors Claudy Antoine, Owner	568 William St, East Orange, NJ 07017 568 William St., East Orange, NJ 07017	02/19/2022
C&N Interiors, LLC Amber Laudenslager, Managing Member	33 Edgewood Road, Boyertown, PA 19512 33 Edgewood Road, Boyertown, PA 19512	04/08/2022
CBC Enterprises LLC Leo Baiocco, President	424 Commerce Lane, West Berlin, NJ 08091 2383 Atco Avenue, Atco, NJ 08004	03/05/2021
CK Petrasso Fabrication & Services Inc Colleen Bolleen, Owner / Officer Paul Petrasso, Vice-President	1337 W Bensalem Ave, Bensalem, PA 19020 1337 W. Bensalem Ave, Bensalem, PA 19020 1337 W. bensalem Ave, Bensalem, PA 19020	12/02/2022
Cleworth & Son, Inc. Dorothy Cleworth, President Ernest Cleworth, Vice-President	3150 Highway 27, Kendall Park, NJ 08824 3150 Highway 27, Kendall Park, NJ 08824 5 Burnham Court, Kendall Park, NJ 08824	07/22/2021
Code Green Solar,LLC. Code Green Solar, L.L.C. Charles Kartsaklis, Managing Member	204 Chelsea Ave., Davenport, FL 33837 204 Chelsea Ave, Davenport, FL 33837	10/12/2023
Complete Wall Specialties Inc. Darryl Wooley, Owner	P.O. Box 36, Williams Bay, WI 53191 4703 Pebble Drive, Elkhorn, WI 53191	04/24/2022
CT GENERAL CONTRACTORS LLC Hector Tigreros, Owner	216 Jeremiah Ave, Hamilton, NJ 08610 216 Jeremiah Ave, Hamilton, NJ 08610	07/01/2022
Dan Seeman Dan Seeman, Owner	1363 North Winchester Dr., Greenfield, IN 46140 1363 North Winchester Dr., Greenfield, IN 46140	03/26/2021
Dan's Tile and Marble LLC Dan's Tile and Marble LLC Dan Jarrell, Owner / Officer	336 McClelland Ave, Glassboro, NJ 08028 336 McClelland Ave, Glassboro, NJ 08028	06/10/2021
Dawkins Plumbing & Construction LLC. Michael Dawkins, Manager	1057 Haddon Ave, Camden, NJ 08103 1057 Haddon Avenue, Camden, NJ 08103	01/01/2021
DiClemente Contractors, Inc. DiClemente Contractors, Inc. Gail Maiello, President	1515 10th Street, Fort Lee, NJ 07024 1515 10th Street, Fort Lee, NJ 07024	12/27/2020
Discovery Floor Covering LLC Segundo Gallegos, Owner Arianna Rengito Miranda, Owner	658 Pennsylvania Ave., Apt. 4, Elizabeth, NJ 07201 528 Linden Ave, Suite 2, Elizabeth, NJ 07202 658 Pennsylvania Ave, Apt 4, Elizabeth, NJ 07201	02/05/2021
Dobtol Construction, L.L.C. Dobtol Construction, L.L.C. Stanislav Tolstunov, President	210 River Street, Ste 21, Hackensack, NJ 07601 20th Avenue, at Port Imperial, West New York, NJ 07093	07/28/2022
Dos Santos & Son Metal Fabrication LLC Nicanor Dos Santos, Owner Julio Dos Santos, President	40 Smith St, Elizabeth, NJ 07201 40 Smith Street, Elizabeth, NJ 07020 , ,	03/11/2023
Duke Electric LLC Duke Electric LLC Craig Dutka, Member Eileen Dutka, Member	600 Rt 33 West, Millstone, NJ 08535 17 Old Church Road, Monroe Township, NJ 08831-0883 17 Old Church Road, Monroe Township, NJ 08831-0883	05/02/2021
EDP Painting Company	7 Wilson Avenue West, East Hanover, NJ 07936	03/27/2021

CONTRACTORS AND SUBCONTRACTORS**ADDRESS****EXPIRATION DATE**

Efficient Electric LLC Efficient Electric LLC Malachi Velez, Member	c/o Malachi Velez, 6 Hampton Court, Jersey City, NJ 07302 6 Hampton Court, Jersey City, NJ 07302	02/05/2021
Emjack Construction Jaroslaw Suchcicki, Vice-President Emil Kiszko, President	84 Diamond St, Brooklyn, NY 11222 272 Nassau avenue, Brooklyn, NY 11222 4192 Sir Andrew Circle, Doylestown, PA 18902	07/25/2022
Excellent Fence Matt Periera, President	35 Center Avenue, Leonardo, NJ 07737 35 Center Avenue, Leonardo, NJ 07737	02/28/2022
Fine Wall Corporation Fine Wall Corporation Mrudula Shah, President Umakant N. Shah, Vice-President Ronak Shah, Member	1404 Oak Tree Road, Suite 204, Iselin, NJ 08830 10 Boxwood Court, Edison, NJ 08820 10 Boxwood Court, Edison, NJ 08820 10 Boxwood Court, Edison, NJ 08820	02/28/2022
GKR Construction Corp Richard Brown, Owner	471 Beach Rd., Staten Island, NY 10312 471 Beach Road, Staten Island, NY 10312	02/28/2022
GSS Industries, LLC Gary Smith, President	P.O Box 625, Farmingdale, NJ 07727 1001 Cedar Lane, Brielle, NJ 08730	09/23/2021
Hernandez Electric Inc. Hernandez Electric Inc. Smerlin Hernandez, Owner	21 Warren Street, Bergenfield, NJ 07621 21 Warren St, Bergenfield, NJ 07621	09/29/2023
Infinity Flooring Infinity Performance Inc. George Atkinson, President	7002 N. Park Ave., Indianapolis, IN 46220 6735 N. Meridian St., Indianapolis, IN 46260	01/08/2021
International Cabling Systems Anthony Nunez, Owner Nercido Nunez, President	2571 Arthur Kill Road, Staten Island, NY 10309 363 Abingdon Avenue, Staten Island, NY 10308 4394 Victory Blvd, Staten Island, NY 10314	05/15/2022
JAJ Construction LLC Stuart Erling, Vice-President Andrew Erling, Manager	3 Little John Road, Morris Plains, NJ 07950 3 Little John Road, Morris Plains, NJ 07950 1017 Jefferson Street, Apt. 302, Hoboken, NJ 07030	03/07/2022
James Dean Custom Carpentry, LLC James Dean, President	115 Darien Road, Howell, NJ 07731 115 Darien Road, Howell, NJ 07731	07/28/2023
John Jackson Masonry & Construction John Jackson, CEO	1133 W. America Rd., Camden, NJ 08104 1771 Norris St., Camden, NJ 08101	09/03/2021
JSV Construction Jose Santos, Owner	Po Box 9010, North Bergen, NJ 07047 1134 91st Street, North Bergen, NJ 07047-0704	08/05/2023
JTG Construction Inc. JTG Construction Inc. Ana Pimenta, President	188 Jefferson Street, Suite 387, Newark, NJ 07105 41 Hamilton Avenue, Kearny, NJ 07032	05/14/2022
Juarez Construction Juan Juarez Juan Benigno Juarez, Owner	261 Union Ave, Paterson, NJ 07502 261 Union Ave, Paterson, NJ 07502	07/19/2023
KBD Construction LLC KBD Construction LLC Dusan Budinoski, President Kalinka Budinoski, Owner	118 B Donor Avenue, Elmwood Park, NJ 07407 118 B Donor Avenue, Elmwood Park, NJ 07407 118 B Donor Avenue, Elmwood Park, NJ 07407	07/08/2021
KMD Excavating, LLC KMD Excavating, LLC John Desmelyk, President	3 N Alward Avenue, Basking Ridge, NJ 07920 3 N. Alward Ave, Basking Ridge, NJ 07920	02/17/2023
L & N General Contractors LLC Sammie Nelson, Member	529 Forest Court, Williamstown, NJ 08094 529 Forest Ct., Williamstown, NJ 08094	08/13/2021

CONTRACTORS AND SUBCONTRACTORS**ADDRESS****EXPIRATION DATE**

Lane Mechanical Heating and Cooling LLC Louis Malvasi, Managing Member	339 Broadway,, Suite B, Long Branch, NJ 07740 158 Whispering Pines Driv, Lincroft, NJ 07738	08/25/2022
LCC CONSTRUCTION LIMITED LIABILITY COMPANY LCC CONSTRUCTION, LLC Liliane Costa, Owner	27 Clayton Ave., Monroe, NJ 08831 27 Clayton Ave, Monroe, NJ 08831	09/06/2021
M.A.C. Installation LLC Iberico Goncalves, Owner	305 10th Ave, Roselle, NJ 07203 305 E. 10th Ave, Roselle, NJ 07203	07/05/2021
Manny Pereira Contracting Manny Periera, President	PO Box 746, Waretown, NJ 08758 P.O. Box 545, Waretown, NJ 08758	02/24/2022
Manto Mechanical Mantas Ambrazavicius, Owner	74 Morton Street, Bridgewater, NJ 08807 74 Morton Street, Bridgewater, NJ 08807	11/18/2021
Marrero Glass and Metal Inc Jaime Marrero, President Maddalena Marrero, Treasurer	Po Box 547, Chalfont, PA 18914 60 Falcon Drive, Chalfont, PA 18914-1891 60 Falcon Drive, Chalfont, PA 18914	09/16/2021
Matrix Management Const. LLC Kenneth Hicks, Owner	2 New Castle Lane, Willingboro, NJ 08046 2 New CAstle Lane, Willingboro, NJ 08046	11/28/2020
Mirror and Glass Depot LLC Sandra Agudelo, Owner	8555 Tonnelle Avenue, Ste-202, North Bergen, NJ 07047 30 Madison Street, East Rutherford, NJ 07073	05/02/2021
Mosner Custom Building Tim Mosner, Owner	738 Adeline St., Trenton, NJ 08611 2 Waltham Ct, Hamilton, NJ 08690	02/28/2022
Mugrose Construction, Inc. Jeffrey Mazur, President	195 Fairfield Avenue, Suite 2C, West Caldwell, NJ 07006 28 Broadlawn Dr., Livingston, NJ 07039	12/04/2022
NJA Services LLC Boguslaw Rzadkowski, Owner	60 Palisade Ave., Suite103, Garfield, NJ 07026 300 Mount Prospect Ave, Clifton, NJ 07012	11/13/2021
North Jersey Pro Builders, LLC Keith Mellan, Owner	333 Godwin Ave, Midland Park, NJ 07432 71 Homestead Lane, Lincoln Park, NJ 07035	09/28/2023
On-Site Contractors NJ, LLC Judy Fumero, Member	230 Locust Ave., Garwood, NJ 07090 230 Locust Avenue, Garwood, NJ 07027	02/28/2022
Paul Kochiss, LLC Paul Kochiss, Managing Member	41 Little Punkup Rd, Oxford, CT 06478 41 Little Punkup Rd, Oxford, CT 06478	07/31/2021
Perna Construction LLC Robert Perna Sr, Managing Member	730 9th Street, Hammonton, NJ 08037-0803 730 9th Street, Hammonton, NJ 08037-0803	05/29/2022
PFC Services LLC Michael Alexeev, President	174 Lighthouse Cove Loop, Carolina Shores, NC 28467 174 Lighthouse Cove Loop, Carolina Shores, NC 28467	11/18/2021
Phil's Home Improvement LLC Phil's Home Improvement LLC Fadil (Phil) Ramadan, Owner	28 Eldorado Drive, Wayne, NJ 07470 28 Eldorado Drive, Wayne, NJ 07407	05/31/2023
Pin Tribal Construction, LLC Mark W. Holmes Sr., President	50 Drift Avenue, Lawrence, NJ 08648 50 Drift Avenue, Lawrence, NJ 08648	01/29/2021
PL&J Construction Corp. Luis Palaguachi, Owner	73 Chestnut St., West Orange, NJ 07052 73 Chestnut Street, West Orange, NJ 07052	11/28/2020
Premier Builders, Inc. Christopher Escher, President Donna Escher, Secretary	1015 Big Oak Road, Yardley, PA 19067 1015 Big Oak Road, Yardley, PA 19067 1015 Big Oak Road, Yardley, PA 19067	09/24/2021

CONTRACTORS AND SUBCONTRACTORS**ADDRESS****EXPIRATION DATE**

Premier Security & Electronics, Inc.	253 Main St, Suite 213, Matawan, NJ 07747	09/27/2023
Brandon Clare, Vice-President	2 Church Street, Matawan, NJ 07747	
Rosemary Clare, President	2 Church Street, Matawan, NJ 07747	
R Edge Erector Co Inc	PO Box 573, Pinnacle, NC 27043	12/11/2021
R Edge Erector Co Inc		
Robert Edge, President	607 S. Main St, Kin g, NC 27043	
Residential Concrete Services, LLC	281 Blue Anchor Road, Sicklerville, NJ 08081	02/24/2023
Paul Matz, Owner	281 Blue Anchor Road, Sicklerville, NJ 08081	
Rian Seeman	12433 Pinededle Drive, Indianapolis, IN 46236	03/26/2021
Rian Seeman, Owner	12433 Pinededle Drive, Indianapolis, IN 46236	
Richard Werley	601 Poplar St., Catasauqua, PA 18045	07/31/2021
Richard Werley, Owner	601 Poplar St., Catasauqua, PA 18032	
Rink Systems, Inc.	1103 Hershey Street, Albert Lea, MN 56007	08/26/2021
Steven Overgaard, Vice-President	3033 Bridge Avenue, Albert Lea, MN 56007	
Stacey Overgaard, President	410 Hammer Road, Albert Lea, MN 56007	
S H Stevens	5043 Ridge Ave, Egg Harbor, NJ 08234	09/26/2022
Scott Stevens, Owner	5043 Ridge Ave, Egg Harbor Twp, NJ 08234	
S&J Floor Covering	10 Ealey St, Glassboro, NJ 08028	04/23/2021
Shawn Dougherty, Owner	10 Ealey Street, Glassboro, NJ 08028	
S. Moyer Enterprises	6271 W. Basalt Cove, West Jordan, UT 84081	03/26/2021
Steve Moyer, Owner	6271 W. Basalt Cove, West Jordan, UT 84081	
SCA Technologies, LLC	3579 Route 46, Apt 52b, Parsippany, NJ 07054	03/26/2021
Scott Ahart, Member	3579 Route 46, Apt 52 b, Parsippany, NJ 07054	
Smith Glass & Metal Company, LLC	766 Ramsey Avenue, Hillside, NJ 07205	10/05/2023
Vincent Fiorito, Vice-President	713 Page Avenue, Lyndhurst, NJ 07071	
Susan Fiorito, President	713 Page Avenue, Lyndhurst, NJ 07071	
Solution Construction LLC	540 Lincoln Ave #S-22, Morrisville, PA 19067	07/22/2022
Solution Construction LLC		
Roberto Gonzalaz, Owner	640 Lincoln Ave, Apt B-22, Morrisville, PA 19067	
Somerset Electrical Services	48 Junction Rd., Flemington, NJ 08822	02/05/2021
Ralph Epright, Owner	48 Junction Rd., Flemington, NJ 08822	
Souza Development	1144 Dana Ave, Bensalem, PA 19020	02/15/2022
Elias Souza, Owner	1144 Dana Ave, Bensalem, PA 19020	
Luiz Costa, Vice-President	500 Myrtle Ave., Horsham, PA 19044	
TDJ METAL PANEL INSTALLERS LLC	913 East 7th Street, Plainfield, NJ 07062	01/30/2022
Trey Johnson, Member	913 East 7th Street, Plainfield, NJ 07062	
Troy Johnson, Managing Member	913 East 7th Street, Plainfield, NJ 07062	
Team Revolution LLC dba Superior Landscaping	6 Warren Dr. Unit D, Vernon, NJ 07462	05/30/2021
William Hattrich, Owner	1 Zinnia Dr., Glenwood, NJ 07462	
Total Flooring LLC	14 Kennedy Drive, Flanders, NJ 07836	01/06/2022
Christopher Lockman, President	14 Kennedy Drive, Flanders, NJ 07836	
Ultra Construction LLC	PO Box 1843, Toms River, NJ 08755	12/14/2020
Ultra Construction Limited Liability Company		
Suzanne Zimmermann, Member	2303 Owen Court, Toms River, NJ 08755	
Christopher Zimmermann, Manager	2303 Owen Court, Toms River, NJ 08755	
Unique Concrete LLC	29 Twin Oaks Dr, Bridgeton, NJ 08302	11/19/2022
Rudolph Reid, Owner	29 Twin Oaks Dr, Bridgeton, NJ 08302-0830	

CONTRACTORS AND SUBCONTRACTORS**ADDRESS****EXPIRATION DATE**

WATER PROOF PROPERTIES, LLC Melida A. Bermeo Crespo, Member	825 Grove Street, Elizabeth, NJ 07202 825 Grove St, Elizabeth, NJ 07202	01/08/2023
Whittendale Excavating Corp. Whittendale Excavating Corp. Timothy Whittendale, Vice-President Roland J. Whittendale, Vice-President Diane Whittendale, President Ashley Whittendale, Partner Matthew Whittendale, Partner	1490 Glen Avenue, Moorestown, NJ 08057 201 Cambridge Drive, Cinnaminson, NJ 08077 309 Fairview Avenue, Moorestown, NJ 08057 1490 Glen Ave., Moorestown, NJ 08057 737 Haverford Avenue, Maple Shade, NJ 08052 112 Homestead Court, Moorestown, NJ 08057	05/07/2021
Woerner Plumbing & Heating Joseph Woerner, Owner	3 Coppermine Village, Flemington, NJ 08822 3 Coppermine Village, Flemington, NJ	04/23/2021
Woodworkers Corporation Renata Moro, President	105 Rome Street, Newark, NJ 07105 305 E. 10th Ave, Roselle, NJ 07203	07/05/2021

LIST OF DEBARRED OWNERS/OFFICERS

10/26/2020

<u>Owners/ Officers</u>	<u>Address</u>	<u>Company Name</u>
Sandra Agudelo, Owner	30 Madison Street, East Rutherford, NJ 07073	Mirror and Glass Depot LLC
Scott Ahart, Member	3579 Route 46, Apt 52 b, Parsippany, NJ 07054	SCA Technologies, LLC
Michael Alexeev, President	174 Lighthouse Cove Loop, Carolina Shores, NC 28467	PFC Services LLC
Elvin Alvarez, Owner	907 Madison Avenue, Elizabeth, NJ 07201	Alvarez Painting, LLC
Mantas Ambrazavicius, Owner	74 Morton Street, Bridgewater, NJ 08807	Manto Mechanical
Claudy Antoine, Owner	568 William St., East Orange, NJ 07017	C C & C General Contractors
George Atkinson, President	6735 N. Meridian St., Indianapolis, IN 46260	Infinity Flooring
Leo Baiocco, President	2383 Atco Avenue, Atco, NJ 08004	Infinity Performance Inc.
Melida A. Bermeo Crespo, Member	825 Grove St, Elizabeth, NJ 07202	CBC Enterprises LLC
Colleen Bolleen, Owner / Officer	1337 W. Bensalem Ave, Bensalem, PA 19020	WATER PROOF PROPERTIES, LLC
Richard Brown, Owner	471 Beach Road, Staten Island, NY 10312	CK Petrasso Fabrication & Services Inc
Dusan Budinoski, President	118 B Donor Avenue, Elmwood Park, NJ 07407	GKR Construction Corp
Kalinka Budinoski, Owner	118 B Donor Avenue, Elmwood Park, NJ 07407	KBD Construction LLC
Sonia Burke, President	3 Brandywine Court, Randolph, NJ 07869-0786	KBD Construction LLC
Rosemary Clare, President	2 Church Street, Matawan, NJ 07747	KBD Construction LLC
Brandon Clare, Vice-President	2 Church Street, Matawan, NJ 07747	KBD Construction LLC
Dorothy Cleworth, President	3150 Highway 27, Kendall Park, NJ 08824	Brickhouse Construction Inc
Ernest Cleworth, Vice-President	5 Burnham Court, Kendall Park, NJ 08824	BRICKHOUSE CONSTRUCTION INC
Liliane Costa, Owner	27 Clayton Ave, Monroe, NJ 08831	Premier Security & Electronics, Inc.
Luiz Costa, Vice-President	500 Myrtle Ave., Horsham, PA 19044	Premier Security & Electronics, Inc.
Michael Dawkins, Manager	1057 Haddon Avenue, Camden, NJ 08103	Cleworth & Son, Inc.
James Dean, President	115 Darien Road, Howell, NJ 07731	Cleworth & Son, Inc.
John Desmelyk, President	3 N. Alward Ave, Basking Ridge, NJ 07920	LCC CONSTRUCTION LIMITED LIABILITY COMPANY
Julio Dos Santos, President	, ,	LCC CONSTRUCTION, LLC
Nicanor Dos Santos, Owner	40 Smith Street, Elizabeth, NJ 07020	Souza Development
Shawn Dougherty, Owner	10 Ealey Street, Glassboro, NJ 08028	Dawkins Plumbing & Construction LLC.
Eileen Dutka, Member	17 Old Church Road, Monroe Township, NJ 08831-0883	James Dean Custom Carpentry, LLC
Craig Dutka, Member	17 Old Church Road, Monroe Township, NJ 08831-0883	KMD Excavating, LLC
Robert Edge, President	607 S. Main St, Kin g, NC 27043	KMD Excavating, LLC
Ralph Epright, Owner	48 Junction Rd., Flemington, NJ 08822	Dos Santos & Son Metal Fabrication LLC
Andrew Erling, Manager	1017 Jefferson Street, Apt. 302, Hoboken, NJ 07030	Dos Santos & Son Metal Fabrication LLC
Stuart Erling, Vice-President	3 Little John Road, Morris Plains, NJ 07950	S&J Floor Covering
Christopher Escher, President	1015 Big Oak Road, Yardley, PA 19067	Duke Electric LLC
Donna Escher, Secretary	1015 Big Oak Road, Yardley, PA 19067	Duke Electric LLC
Adam Fernando, Owner	1546 Wooded Acres Drive, Stroudburg, PA 18360	Duke Electric LLC
Theodore Fiore Jr, Owner	9 Silver Spring Court, East Hanover, NJ 07936-2529	Duke Electric LLC
Susan Fiorito, President	713 Page Avenue, Lyndhurst, NJ 07071	R Edge Erector Co Inc
Vincent Fiorito, Vice-President	713 Page Avenue, Lyndhurst, NJ 07071	R Edge Erector Co Inc
Judy Fumero, Member	230 Locust Avenue, Garwood, NJ 07027	Somerset Electrical Services
Segundo Gallegos, Owner	528 Linden Ave, Suite 2, Elizabeth, NJ 07202	JAJ Construction LLC
Iberico Goncalves, Owner	305 E. 10th Ave, Roselle, NJ 07203	JAJ Construction LLC

<u>Owners/ Officers</u>	<u>Address</u>	<u>Company Name</u>
Roberto Gonzalaz, Owner	640 Lincoln Ave, Apt B-22, Morrisville, PA 19067	Solution Construction LLC Solution Construction LLC
William Hattrich, Owner	1 Zinnia Dr., Glenwood, NJ 07462	Team Revolution LLC dba Superior Landscaping
Smerlin Hernandez, Owner	21 Warren St, Bergenfield, NJ 07621	Hernandez Electric Inc. Hernandez Electric Inc.
Kenneth Hicks, Owner	2 New Castle Lane, Willingboro, NJ 08046	Matrix Management Const. LLC
Mark W. Holmes Sr., President	50 Drift Avenue, Lawrence, NJ 08648	Pin Tribal Construction, LLC
John Hunsecker, Vice-President	72 Charlotte Drive, Churchville, PA 18966	Bravo General Contractors Inc
John Jackson, CEO	1771 Norris St., Camden, NJ 08101	John Jackson Masonry & Construction
Dan Jarrell, Owner / Officer	336 McClelland Ave, Glassboro, NJ 08028	Dan's Tile and Marble LLC Dan's Tile and Marble LLC
Trey Johnson, Member	913 East 7th Street, Plainfield, NJ 07062	TDJ METAL PANEL INSTALLERS LLC
Troy Johnson, Managing Member	913 East 7th Street, Plainfield, NJ 07062	TDJ METAL PANEL INSTALLERS LLC
Juan Benigno Juarez, Owner	261 Union Ave, Paterson, NJ 07502	Juarez Construction Juan Juarez
Charles Kartsaklis, Managing Member	204 Chelsea Ave, Davenport, FL 33837	Code Green Solar,LLC. Code Green Solar, L.L.C.
Emil Kiszko, President	4192 Sir Andrew Circle, Doylestown, PA 18902	Emjack Construction
Paul Kochiss, Managing Member	41 Little Punkup Rd, Oxford, CT 06478	Paul Kochiss, LLC
Amber Laudenslager, Managing Member	33 Edgewood Road, Boyertown, PA 19512	C&N Interiors, LLC
Christopher Lockman, President	14 Kennedy Drive, Flanders, NJ 07836	Total Flooring LLC
Gail Maiello, President	1515 10th Street, Fort Lee, NJ 07024	DiClemente Contractors, Inc. DiClemente Contractors, Inc.
Louis Malvasi, Managing Member	158 Whispering Pines Driv, Lincroft, NJ 07738	Lane Mechanical Heating and Cooling LLC
Maddalena Marrero, Treasurer	60 Falcon Drive, Chalfont, PA 18914	Marrero Glass and Metal Inc
Jaime Marrero, President	60 Falcon Drive, Chalfont, PA 18914-1891	Marrero Glass and Metal Inc
Paul Matz, Owner	281 Blue Anchor Road, Sicklerville, NJ 08081	Residential Concrete Services, LLC
Jeffrey Mazur, President	28 Broadlawn Dr., Livingston, NJ 07039	Mugrose Construction, Inc.
Keith Mellan, Owner	71 Homestead Lane, Lincoln Park, NJ 07035	North Jersey Pro Builders, LLC
Renata Moro, President	305 E. 10th Ave, Roselle, NJ 07203	Woodworkers Corporation
Tim Mosner, Owner	2 Waltham Ct, Hamilton, NJ 08690	Mosner Custom Building
Steve Moyer, Owner	6271 W. Basalt Cove, West Jordan, UT 84081	S. Moyer Enterprises
Sammie Nelson, Member	529 Forest Ct., Williamstown, NJ 08094	L & N General Contractors LLC
Timothy J. Noon, Owner	698 Northstream Drive, Toms River, NJ 08753	Beach Coast Builders LLC TJN Development LLC
Anthony Nunez, Owner	363 Abingdon Avenue, Staten Island, NY 10308	International Cabling Systems
Nercido Nunez, President	4394 Victory Blvd, Staten Island, NY 10314	International Cabling Systems
Joseph O'Brien, Owner / Officer	171 Cedar Lane West, Cape May Court House, NJ 08210	Building Construction Management LLC
Stacey Overgaard, President	410 Hammer Road, Albert Lea, MN 56007	Rink Systems, Inc.
Steven Overgaard, Vice-President	3033 Bridge Avenue, Albert Lea, MN 56007	Rink Systems, Inc.
Luis Palaguachi, Owner	73 Chestnut Street, West Orange, NJ 07052	PL&J Construction Corp.
Matt Periera, President	35 Center Avenue, Leonardo, NJ 07737	Excellent Fence
Manny Periera, President	P.O. Box 545, Waretown, NJ 08758	Manny Pereira Contracting
Adelino Perin, President	12 Valley Place, Chester, NJ 07930	A P Roofing & Siding, LLC A. Perin Roofing & Siding, LLC
Robert Perna Sr, Managing Member	730 9th Street, Hammonton, NJ 08037-0803	Perna Construction LLC
Paul Petrasso, Vice-President	1337 W. bensalem Ave, Bensalem, PA 19020	CK Petrasso Fabrication & Services Inc
Ana Pimenta, President	41 Hamilton Avenue, Kearny, NJ 07032	JTG Construction Inc. JTG Construction Inc.
Helayne Queiroz, Vice-President	3 Laila Ct, Monroe, NJ 08831-0883	BRASUSA CONSTRUCTION INC
Fabricio Queiroz, President	3 Laila Ct, Monroe, NJ 08831-0883	BRASUSA CONSTRUCTION INC
Fadil (Phil) Ramadan, Owner	28 Eldorado Drive, Wayne, NJ 07407	Phil's Home Improvement LLC Phil's Home Improvement LLC
Rudolph Reid, Owner	29 Twin Oaks Dr, Bridgeton, NJ 08302-0830	Unique Concrete LLC
Arianna Rengito Miranda, Owner	658 Pennsylvania Ave, Apt 4, Elizabeth, NJ 07201	Discovery Floor Covering LLC

